

CP6000 Construction Signoff Form

Review datasheets, site design, and installation guides defining ChargePoint specifications at: chargepoint.com/guides.

IMPORTANT: All installations must comply with local and regional code. ChargePoint provides concrete pad guidance in the [CP6000 Site Design Guide](#) that is applicable for most sites; however, pad sizes may vary. Ensure site drawings have been completed and approved by a structural engineer for this site.

Customer Information	
Customer name	
Customer contact name	
Customer contact phone	
Customer contact email	

Site Information	
Street and number	
City	
Country	
Post code	
Number of stations to be installed	
Number of paired stations to be installed (if applicable)	
Estimated construction start date	
Estimated installation and commissioning date	

Site Contractor Information	
Contractor type	ChargePoint designated
	Customer designated
Contractor company name	
Contractor site lead name	
Contractor site lead phone	
Contractor site lead email	



Installer Information	
Installer type	ChargePoint recommended
	Customer recommended
Installation company name	
Installer contact name	
Installer contact phone	
Installer contact email	

Note: If the station installer arrives to install the charging station and finds these items incomplete, you will incur a separate re-dispatch fee.

 Required Pictures - Upload to Appendix A
(Take photos for each location throughout the site construction process and select the links below to attach photos.)
1. <u>All trenching completed, showing conduit/ducting is in place.</u>
2. <u>Concrete pad completed, showing anchor bolts and duct or conduit stub-ups in place OR wall station location with flex conduit and wire for each station.</u>
3. <u>Overall space around each mounting location, showing all service clearances are available.</u>
4. <u>The electrical panel's specification label, showing total panel configuration and capacity.</u>
5. <u>An open electrical panel with the dead front panel removed, showing terminations.</u>
6. <u>An open electrical panel with the dead front panel on, showing breaker amperage ratings and labels for connections.</u>
7. <u>All CP6000 charging station sites are correctly oriented.</u>
8. <u>Circuit capacity.</u>

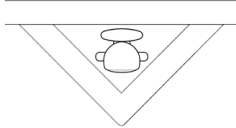
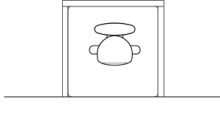
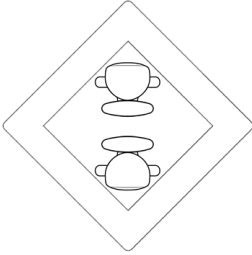
Civil Work, Pedestal Mount	Indicate Yes or No Add Comments	
<p>1. ChargePoint recommends: The concrete pad was designed and approved by a structural engineer for this specific site, or supports these specifications:</p> <ul style="list-style-type: none"> • Concrete C30 - 30 N/mm² and achieves 2/3 of its design strength in 7 days - Follow concrete manufacturer mix recommendations • At least 600 mm (24 in) on each side, including depth • Follows one of the three recommended pedestal patterns in the Site Design Guide: In front of a curb 900 mm (3 ft) x 2 Area: 0.42 m² (4.5 ft²) Volume: 0.26 m³ (9 ft³)  <ul style="list-style-type: none"> • Behind a curb in a planter or berm 600 mm (2 ft) on each side Area: 0.37 m² (4 ft²) Volume: 0.23 m³ (8 ft³)  <p>Two stations back to back, centered between four spaces 900 mm (3 ft) on each side Area: 0.84 m² (9 ft²) Volume: 0.51 m³ (18 ft³)</p>  <p>-or- Existing concrete with:</p> <ul style="list-style-type: none"> • A minimum concrete volume of 0.23 m³ (8 ft³) • A minimum concrete depth of at least 150 mm (6 in) thick • Mounting bolts or chemical anchors (not expanding bolts) positioned at least 153 mm (6 in) from the edges of the pad when measured from the center of any bolt 	Yes	No
<p>2. Three anchor bolts must extend 60 mm (2 1/3 in) but not more than 100 mm (4 in) above the concrete, with two bolts in the front and one bolt behind the duct or conduit stub-up. Bolts are plumb and secure in concrete or epoxy.</p>	Yes	No
<p>3. The center of the duct or conduit stub-up for a pedestal mount station with a CMK is at least 245 mm (9.65 in) from obstructions to the rear. The</p>	Yes	No

Civil Work, Pedestal Mount		Indicate Yes or No Add Comments	
	center of the duct or conduit stub-up for a pedestal mount station without a CMK is at least 147 mm (5.8 in) from obstructions to the rear.		
4.	Ducts or conduit stub-ups measure between 152 mm (6 in) and 590 mm (2 ft) above grade.	Yes	No
5.	Ensure any site slopes, walls, or fencing do not trap water around the charging station installation site. The system is only built to withstand water to the height of the duct or conduit stub-up.	Yes	No
6.	Are the concrete pad's edges smooth? Only for pedestal mounted installations	Yes	No
7.	Is the slope of the pad less than 2%, or 6 mm per 300 mm or 1/2 in per 25 in? Only for pedestal mounted installations	Yes	No
8.	Are the site conditions conforming to the nominal pad? (i.e., 600 x 600 x 600 mm)? Only for pedestal mounted installations	Yes	No



IMPORTANT: You must use a ChargePoint CP6000 Concrete Mounting Template (CMT) for pedestal mount station installations. Refer to the CP6000 Site Design Guide on chargepoint.com/guides for more information.

You should see the following:

	Indicate Yes or No Add Comments	
a. Concrete mounting template	Yes	No
b. Three bolts set into concrete	Yes	No
c. Two nuts and three washers on each bolt	Yes	No
d. Template front	Yes	No
e. Bolts extending 60 mm (2 1/3 in) to 100 mm (4 in)	Yes	No
f. Conduit stub-up measuring 152 mm (6 in) to 590 mm (2 ft)	Yes	No

	Indicate Yes or No Add Comments	
g. Approximately 1.5 m (5 ft) of service wiring	Yes	No
h. CP6000 adapter cover (only if replacing CP6000)	Yes	No

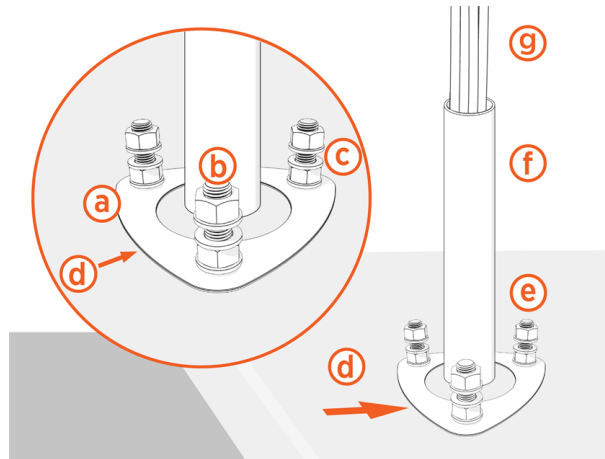

Note: In case any of the above items are missing, contact ChargePoint Support.

Pedestal Mount with Cable Management Kit (CMK)

Note: Images are not to scale. Measurements appear in metric units (mm) followed by imperial equivalents (inches).

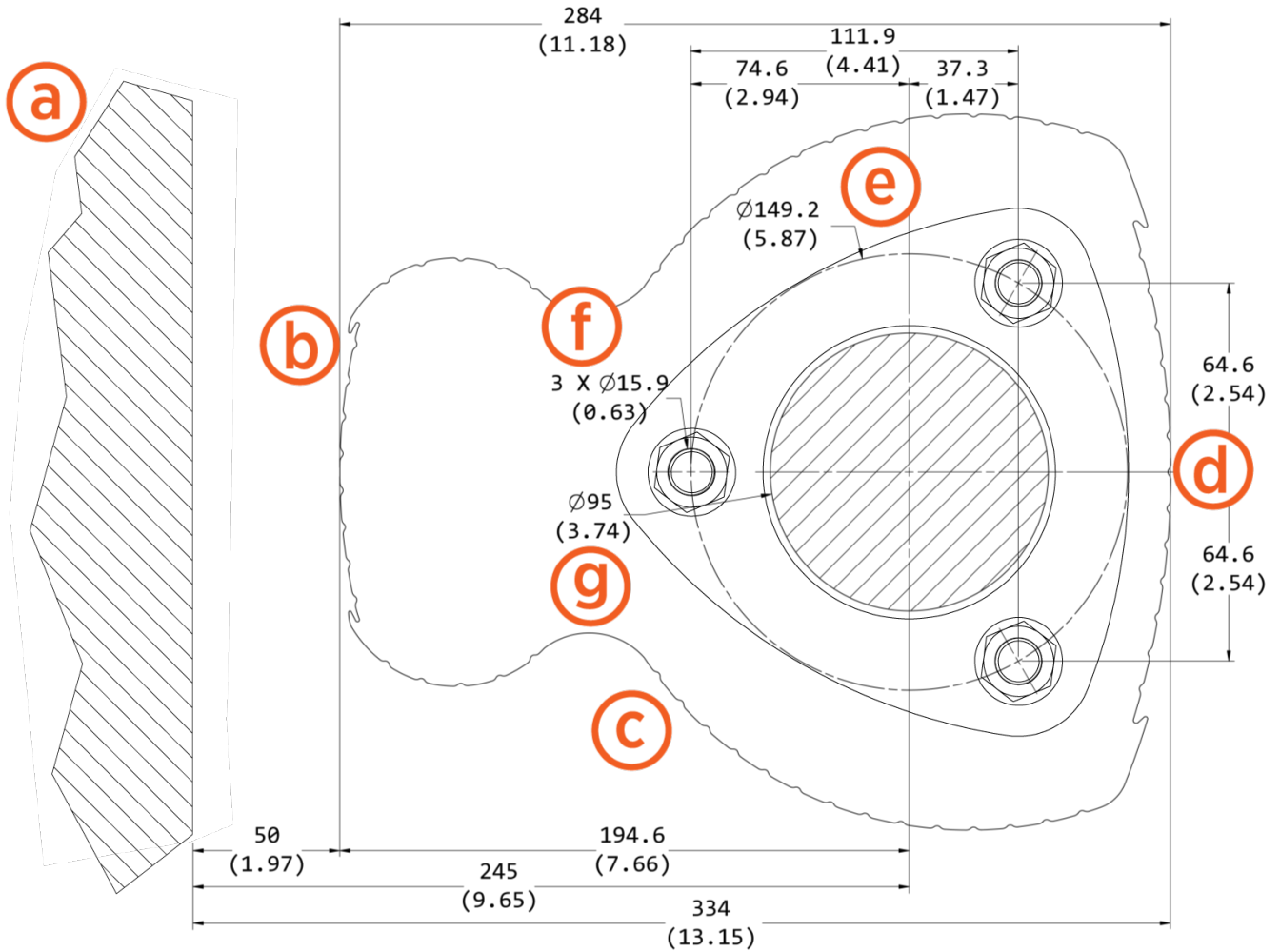

	Indicate Yes or No Add Comments	
a. Wall	Yes	No
b. CMK footprint	Yes	No
c. Pedestal footprint	Yes	No
d. Front	Yes	No
e. Bolt circle	Yes	No

	Indicate Yes or No Add Comments	
f. Bolt or anchor	Yes	No
g. Conduit stub-up within this area (new concrete only)	Yes	No

Pedestal Mount without Cable Management Kit (CMK)

Note: Images are not to scale. Measurements appear in metric units (mm) followed by imperial equivalents (inches).

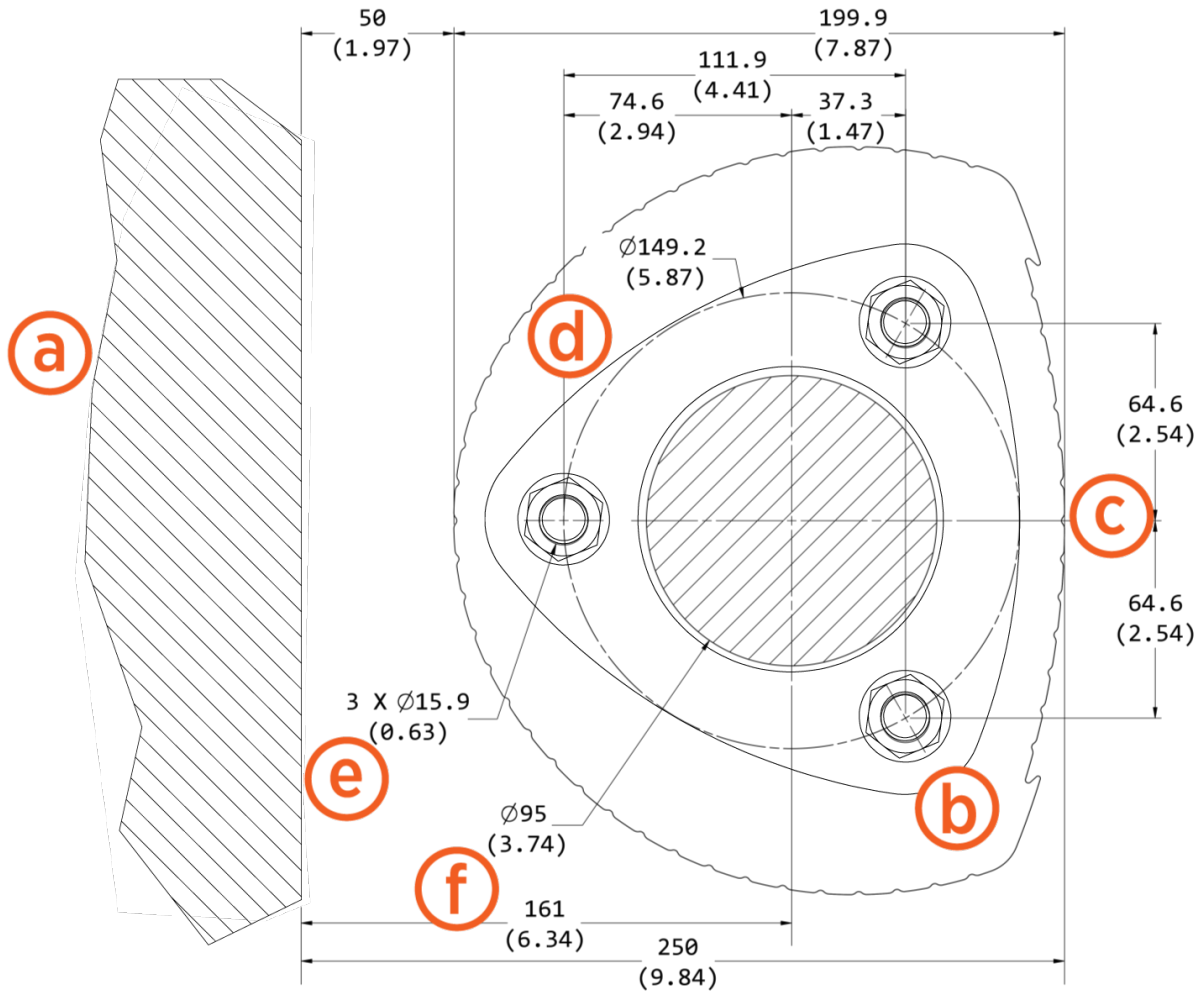

	Indicate Yes or No Add Comments	
a. Wall	Yes	No
b. Pedestal footprint	Yes	No
c. Front	Yes	No
d. Bolt circle	Yes	No

	Indicate Yes or No Add Comments	
e. Bolt or anchor	Yes	No
f. Conduit stub-up within this area	Yes	No

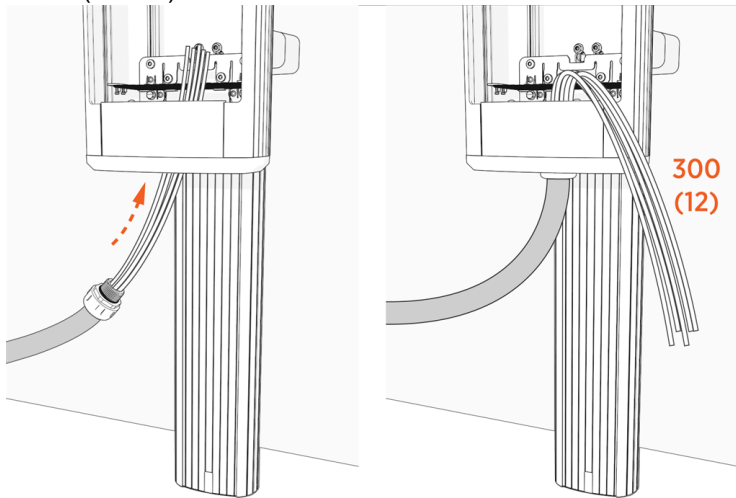
Civil Work, Wall Mount		Indicate Yes or No Add Comments	
1.	<p>Conduit brings wire to the station. Conduit diameter must be at least 19 mm (3/4 in) and cannot exceed 38 mm (1-1/2 in). If larger capacity is required, create two entry points, one on either side of the station, for parallel conductors. If using an armored cable, these are the outer diameters of the cable:</p> <ul style="list-style-type: none"> • 2 x 32 A supply - 22.9 mm (.9 in) • 1 x 64 A supply - 31.5 mm (1.24 in) 	Yes	No
2.	<p>The length of cable from the cable gland or the wall mount base needs to be at least 300 mm (12 in). Note: Measurements appear in metric units (mm), followed by imperial equivalents (inches).</p> 	Yes	No

Wall Mount Bracket Hole Locations

Note: Images are not to scale. Measurements appear in metric units (mm) followed by imperial equivalents (inches).

	Indicate Yes or No Add Comments	
a. Hole locations for wall mount stations without CMKs	Yes	No
b. Hole locations for wall mount stations with CMKs	Yes	No
c. Ground level	Yes	No

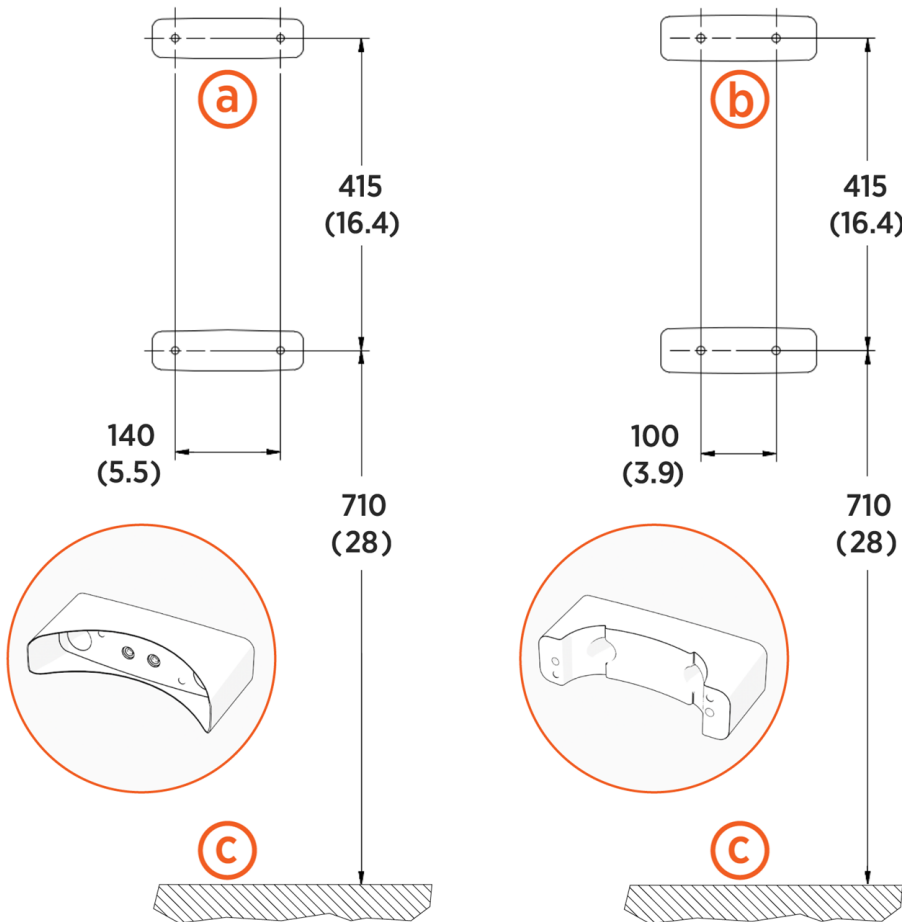

Electrical Work	Select/Value
Electrical infrastructure has been completed in accordance with all applicable codes and ChargePoint specifications.	
Stations are equipped with internal RCCBs. If installing additional RCCBs upstream, they must comply with local codes and meet the following requirements :	
Type A or B	
Recommend minimum 100 mA tripping current	
Capacity current equal or higher than nominal current	
Maximum circuit breaker output:	16 A 20 A 32 A 40 A 63 A
Each circuit breaker is new or in good working order.	
Check each connection and ensure each one is clean and torqued to specifications.	
Breakers in the panel are labeled correctly.	
What is the earthing system? Note: IT and TN-C are not supported. Note: Additional earth protection is required for TN-S and TN-C-S in the form of an O-PEN device.	TN-S TT TN-C-S
Is the O-PEN device fitted?	
Require Picture of the O-PEN device, which is fitted.	
Earth resistance value:	
Earth resistance compliant?	Yes No
Specifications for wire used: Type AWG/mm ² (Max. 25 mm ²) Insulation type Voltage rating Temperature rating	_____ _____ _____ _____ _____

Cable insulation value:

Cables	Result in Kilo Ohm	Confirm?	
L1-L2		Yes	No
L1-L3		Yes	No
L2-L3		Yes	No
L1-N		Yes	No
L2-N		Yes	No
L3-N		Yes	No
L1-PE		Yes	No
L2-PE		Yes	No
L3-PE		Yes	No

Network Connectivity				
<p>Validate Mobile Network and Carrier availability. 2G is only applicable for early version stations.</p> <p>If applicable, 4G Signal RSSP should be better than -90dB. A minimum of -85dB is recommended for good connectivity and smooth operation.</p> <p>If the signal quality is not within these parameters, ChargePoint will charge additional fees.</p>				
Carrier name	4G (dBi)	3G (dBi)	2G (dBi)	Confirm?
1.				Yes No
2.				Yes No

3.				Yes	No
<p>Note: For 3G and 2G, is a signal repeater necessary? Are the readings in the table outside an acceptable range? The installation of signal repeaters is recommended for areas with poor cellular connectivity.</p>					
<p>For UK, devices readily available on the market can be installed. For EU/Continental Europe countries, a repeater should be requested through the local mobile carrier.</p>					
<p>Is a LAN already on site that has an available Ethernet port in the switch/router?</p>	<p>Yes No</p> <p>Note: LAN network is managed by the site host. ChargePoint is only responsible for providing an Ethernet port on the charging station.</p>				
<p>Will Ethernet cables (CAT6 and above) be used to connect to the charging station?</p>	<p>Yes No</p>				
<p>Is the LAN configured in DHCP or Static IP mode?</p>	<p>DHCP Static IP</p> <p>Note: ChargePoint recommends DHCP mode. If specific IP addresses are required, ChargePoint recommends utilizing DHCP Reservation on the network device. If Static IP is selected, please provide the specific IP address.</p> <p>_____</p>				
<p>Does the LAN utilize IPv4?</p>	<p>Yes No</p>				
<p>Is the LAN a shared network?</p>	<p>Yes No</p> <p>Note: ChargePoint recommends an isolated network with device isolation.</p>				
<p>Does the LAN have an outbound firewall?</p>	<p>Yes No</p>				
<p>If firewall is ticked as YES, confirm if the below firewall settings have been changed?</p>	<p>Yes No</p>				

IMPORTANT:

If firewall is ticked as YES, please allow the following connections:

- Usage: HTTPS, Protocol: TCP, Port: 443
- Usage: VPN, Protocol: TCP, Ports: 52007 - 52017
- Usage: NTP, Protocol: UDP, Port: 123

Accessibility

Comply with regional accessibility laws, regulations, and ordinances. The CP6000 charging station must not block ramps or pathways and the height of the interactive display cannot exceed the maximum height as dictated by local laws.

Signage

Refer to local and regional code to design the following elements for the site:

- Any required re-striping of parking spaces
- EV or Accessible EV signs
- EV or Accessible EV paint markings on and around the parking spaces

Site Comments

I, _____ hereby certify that the scope of work in this form has been correctly completed. As a result, neither ChargePoint nor the partner installing the charging stations can be held liable in the event of non-compliance with applicable standards or manufacturer requirements.

Signature	Date



chargepoint.com/support

75-001507-02 r2



Appendix A - Required Pictures

Photo 1

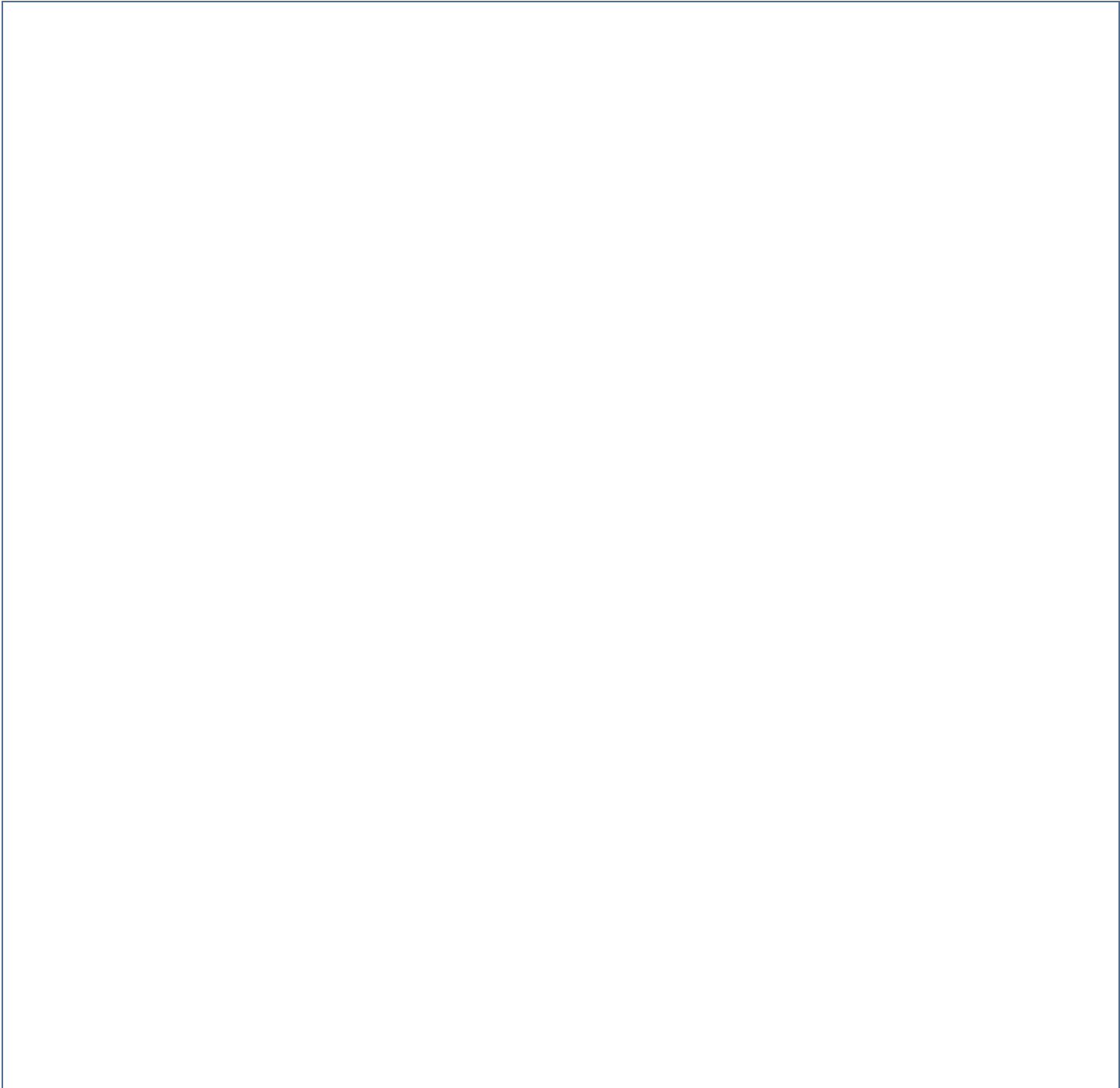



Required Pictures (cont.)

Photo 2





Required Pictures (cont.)

Photo 3

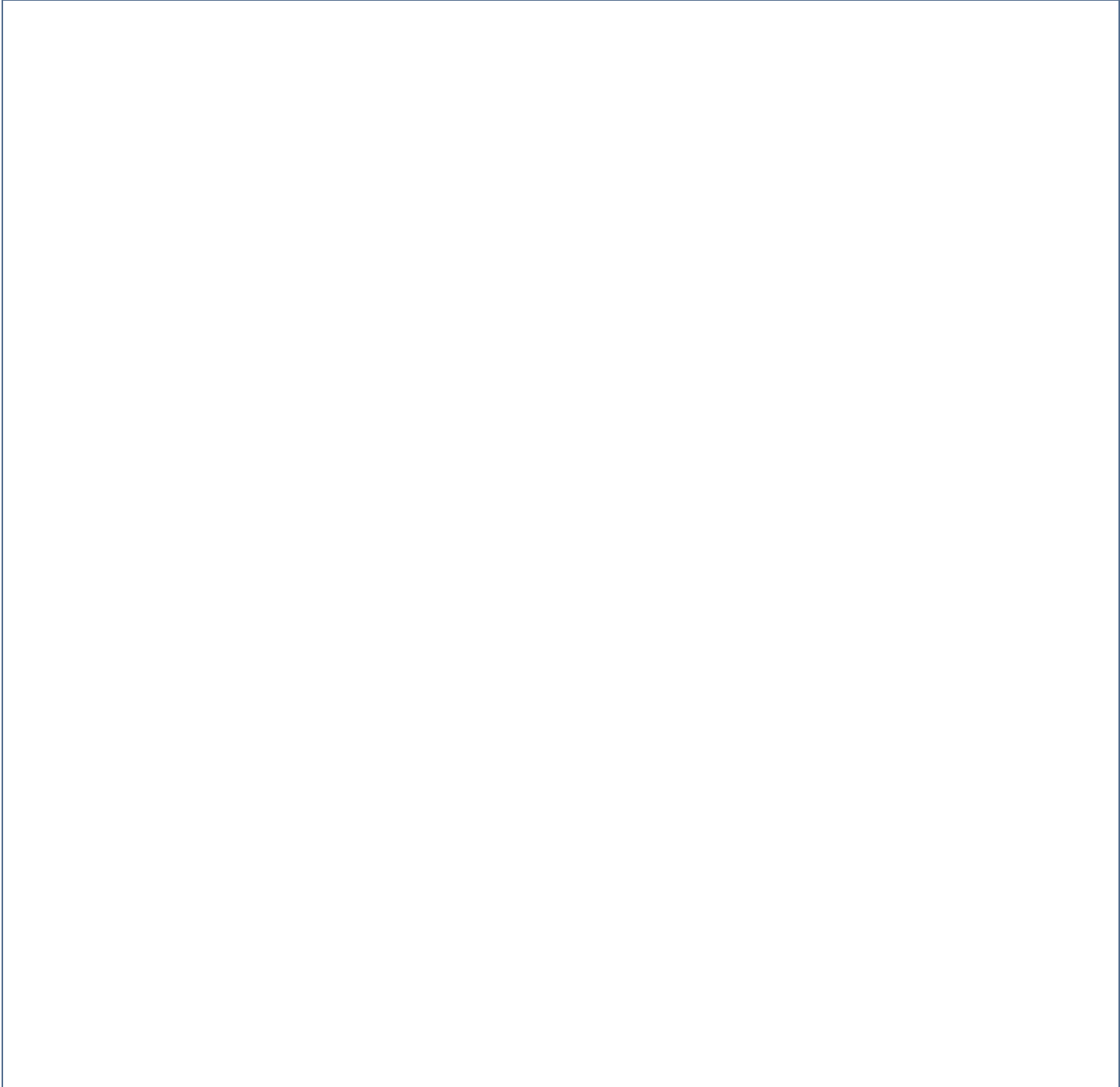



Required Pictures (cont.)

Photo 4





Required Pictures (cont.)

Photo 5

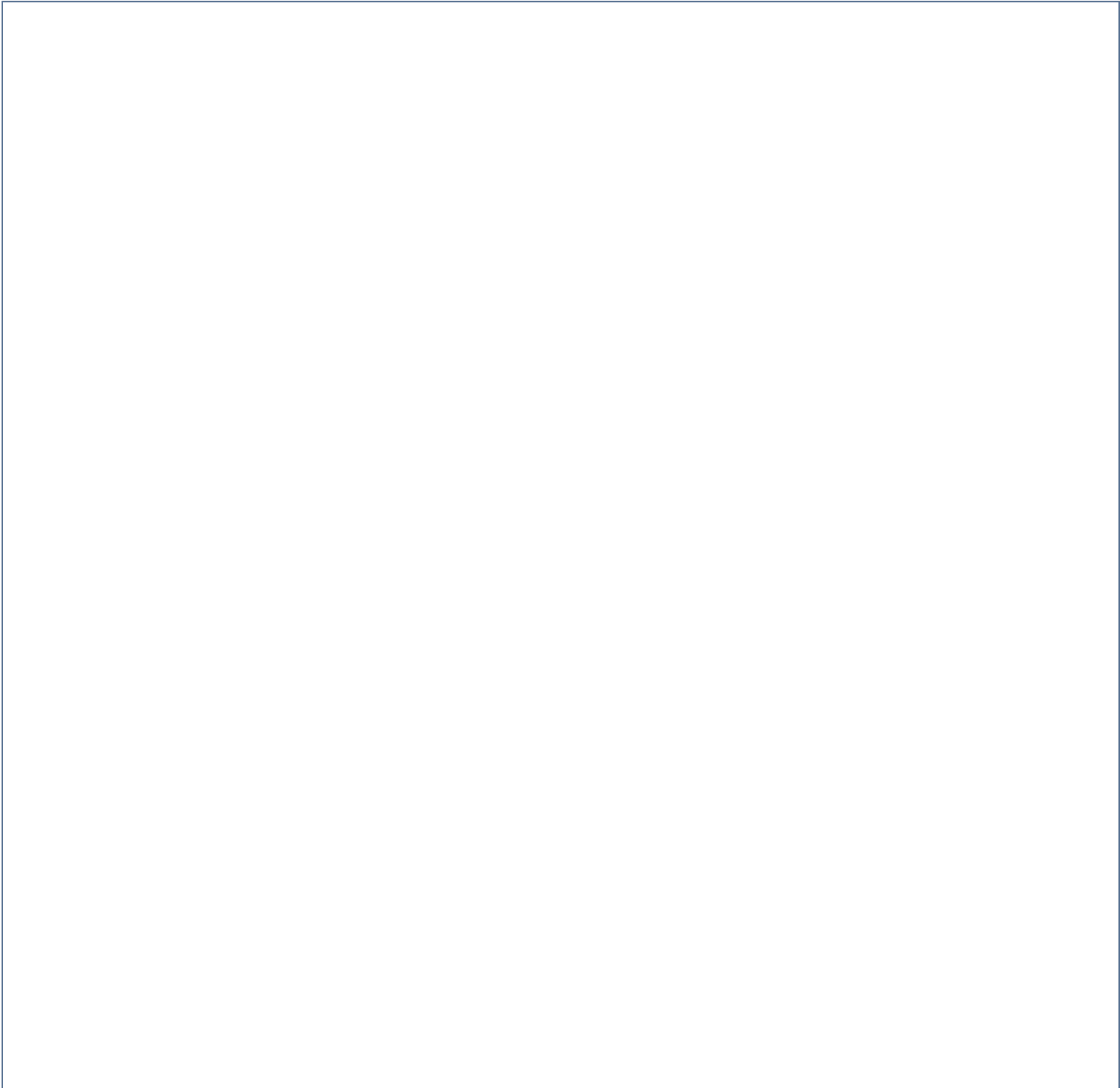



Required Pictures (cont.)

Photo 6





Required Pictures (cont.)

Photo 7





Required Pictures (cont.)

Photo 8

