

## Data Sheet | Item Number: 891-8982/116-102

pre-assembled connecting cable; Eca; Socket/open-ended; 2-pole; Cod. I;  
H05Z1Z1-F 2 x 1,50 mm<sup>2</sup>; 1 m; 1,50 mm<sup>2</sup>; blue

<https://www.wago.com/891-8982/116-102>

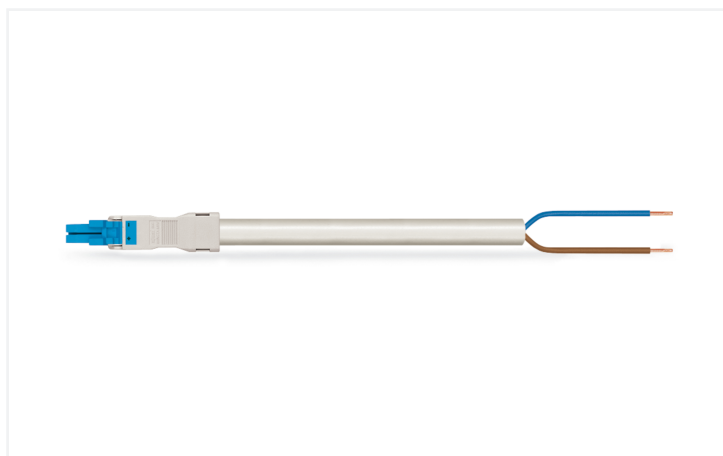

Color: ■ blue

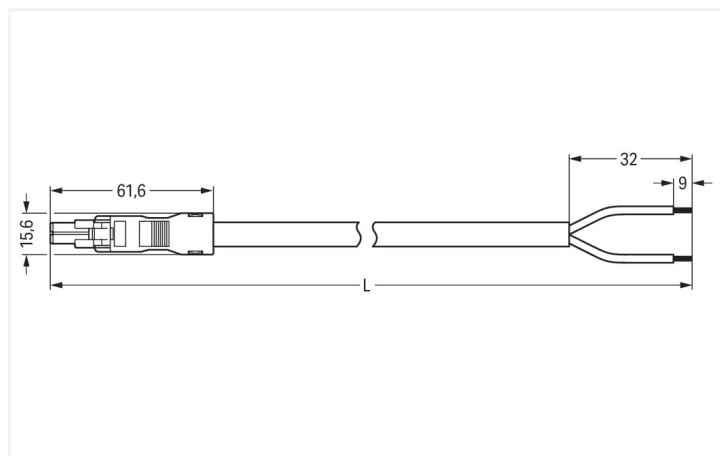

Dimensions in mm

### Cable assembly WINSTA® MINI I coding

The WINSTA® MINI cable assembly with protection type IP40 supports fast, reliable installation. The pluggable installation connectors with spring pressure connection technology work entirely without screw connections. They allow fast, efficient, error-free installation in a large number of applications. For greater security in electrical installations, the pluggable installation connector is provided with mechanical protection against mismatching. The pluggable installation connector is protected against ingress by solid granular objects with a diameter below 1 mm in accordance with protection type IP40. Controlled lighting, as implemented in the DALI standard, for instance, is the main application of WINSTA® MINI pluggable installation connectors with I coding. Due to its particularly minimal dimensions, our WINSTA® MINI Pluggable Connection System with Push-in CAGE CLAMP® spring pressure connection technology is very suitable in very tight spaces, i.e., for connections when very little room is available. Of course, the safety of buildings must always be ensured, even after the electrical installation has been performed. The required safety requirements in connection with EU CPR are met by this product through fire class E. The cable assembly is free of halogen. This eliminates the addition of environmental pollutants during production. It also increases the fire class, since halogen-free materials do not easily ignite.

### Fast, error-free assembly thanks to cable assemblies from WAGO

A socket and a free end are provided. The WINSTA® Pluggable Connection System is perfectly tailored to the very strict requirements of building installation. It makes electrical installation pluggable, and therefore more efficient, more reliable, and error-free. Using this pre-assembled system reduces time spent on assembly and installation errors at the construction site. Take advantage of the pluggable version of our maintenance-free spring pressure connection technology too! Plan your installation with with protection against mismatching from WAGO.

- protection against mismatching eliminates errors
- compact design for conductors with a cross-section up to 1.5 mm<sup>2</sup>
- for lighting management
- custom-engineered solutions
- quick replacement of defective units during ongoing operation

## Notes

Note Cables with a different fire class can be found in the eShop.

## Electrical data

Ratings per	IEC/EN 60664-1			General information	
Overvoltage category	III	III	II	Note on contact resistance	approx. 1 mΩ of contact resistance approx. 0.25 mΩ contact transition plug/ socket
Pollution degree	3	2	2		
Nominal voltage	250 V	-	-		
Rated impulse withstand voltage	4 kV	-	-		
Rated current	16 A	-	-		

## Connection Data

Total number of potentials	2	<b>Connection 1</b>	
Conductor preparation	ultrasonically tip-bonded	Strip length	9 mm / 0.35 inches
		Pole number	2
		Wire cross-section	1.5 mm <sup>2</sup>
		Strip length (outer insulation)	32 mm
		Connection type	Socket - free end

## Physical data

Pin spacing	4.4 mm / 0.173 inches
Width	15.6 mm / 0.614 inches
Height	13.2 mm / 0.52 inches
Total length	1 m

## Mechanical data

Use	DALI, Lighting Management
Coding	I
Variable coding	No
Marking	+ -
Potential marking	+ -
Mating force of a plug-in connection	approx. 20 ... 70 N (depending on pole number)
Retention force of a plug-in connection	when locked: > 80N
Unmating force of a plug-in connection	when unlocked: approx. 20 ... 70 N (depending on pole number)
Number of mating cycles	200, without resistive load
Connection type	Socket - free end
Type of pre-assembled cable	Connecting cable
Cable type	H05Z1Z1-F 2x1.5
Protection type	IP40

### Plug-in connection

Mismating protection	Yes
Note on mismating protection	All WINSTA® components are 100% protected against mismating when: a.) plugging different numbers of poles b.) plugging while rotated 180 c.) plugging while laterally staggered d.) plugging one pole
Locking lever	Can be retrofitted
Locking of plug-in connection	Locking lever
Note on locking system	All connectors for mounted installations (snap-in versions for lighting fixtures or devices, all types of PCB and distribution connectors) are factory-equipped with locking levers to ensure plugs and sockets are securely locked. Additional locking levers are only required for flying leads (plug/socket).

### Material data

Note (material data)	<a href="#">Information on material specifications can be found here</a>
Color	blue
Insulation material (main housing)	Polyamide (PA66)
Fire class per EN 50575	E <sub>ca</sub>
Contact material	Copper or copper alloy; surface-treated
Contact Plating	Tin
Fire load	29.677 MJ
Connector color	blue
Strain relief color	white
Sheathed cable color	white
Printing color of sheathed cable	black
Halogen-free	Yes
Silicon-free	Yes
Sheath material	Halogen-free
Rubber cable	No
Weight	83.5 g
Copper weight of the raw cable	0.029 kg/m

### Environmental requirements

Processing temperature	-5 ... +40 °C
Continuous operating temperature	-35 ... +85 °C
Note on continuous operating temperature	Cable for temperatures ≤ 70 °C (including halogen-free) Insulating parts for temperatures ≤ 105 °C

### Commercial data

PU (SPU)	1 pcs
Packaging type	unpacked
Country of origin	PL
GTIN	4055143392563
Customs tariff number	85444290900

**Product Classification**

UNSPSC	26121629
eCl@ss 10.0	27-44-06-04
eCl@ss 9.0	27-44-06-04
ETIM 9.0	EC002587
ETIM 10.0	EC002587
ECCN	NO US CLASSIFICATION

**Environmental Product Compliance**

RoHS Compliance Status	Compliant, No Exemption
------------------------	-------------------------

**Approvals / Certificates**

**General approvals** **Declarations of conformity and manufacturer's declarations**



Approval	Standard	Certificate Name
CCA DEKRA Certification B.V.	EN 61535	NTR NL-7971
KEMA/KEUR DEKRA Certification B.V.	EN 61535	71-123232

Approval	Standard	Certificate Name
EU-Declaration of Conformity WAGO GmbH & Co. KG	-	-
UK-Declaration of Conformity WAGO GmbH & Co. KG	-	-

**Downloads**

**Environmental Product Compliance**

**Compliance Search**

Environmental Product Compliance 891-8982/116-102	↓
--	---

**Documentation**

**Bid Text**

891-8982/116-102	19.02.2019	xml 3.14 KB	↓
891-8982/116-102	24.11.2014	doc 25.00 KB	↓

**CAD/CAE-Data**

**CAE data**

WSCAD Universe 891-8982/116-102	↓
------------------------------------	---

## 1 Compatible Products

### 1.1 Required Accessories

#### 1.1.1 Locking system

##### 1.1.1.1 Locking system



**Item No.: 890-111**

Locking lever; for flying leads; for tool operation; black

**Item No.: 890-131**

Locking lever; for flying leads; for tool operation; white

**Item No.: 890-101**

Locking lever; for manual operation; black

**Item No.: 890-121**

Locking lever; for manual operation; white

### 1.2 Optional Accessories

#### 1.2.1 Cover

##### 1.2.1.1 Cover



**Item No.: 897-2001**

Protective cap; Type1; for sockets and plugs; PVC; red

#### 1.2.2 Installation

##### 1.2.2.1 Mounting accessories



**Item No.: 890-310**

Mounting carrier; 2- to 5-pole; for flying leads; black

**Item No.: 890-311**

Mounting carrier; 2- to 5-pole; for flying leads; white