

Data Sheet | Item Number: 810-902/000-002

Multi port device tap with mounting foot; 2 trunk cables (input, output); 2 drop cables

<https://www.wago.com/810-902/000-002>

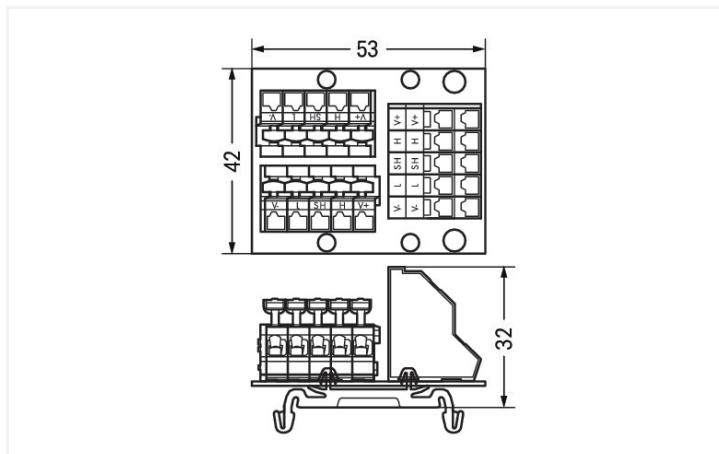
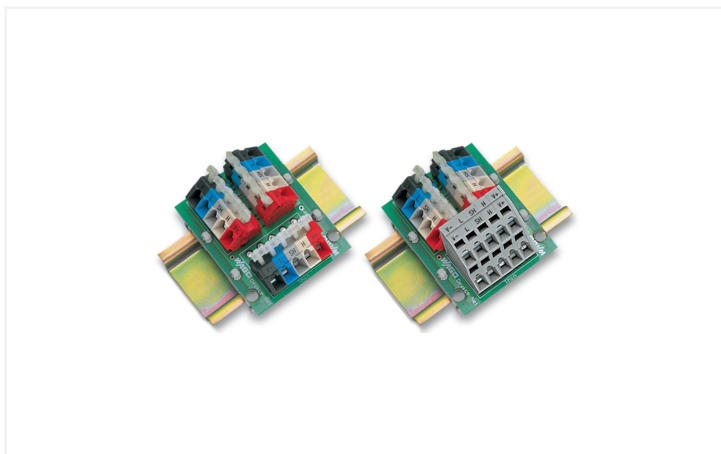

Similar to illustration

Connection Data

Solid conductor	0.08 ... 2.5 mm ² / 28 ... 12 AWG
Connection point (other) designation	Trunk cables
Connection point (other) designation	Drop cables
Connection point (other) connection technology	CAGE CLAMP®
Connection point (other) connection technology	CAGE CLAMP®

Physical data

Width	42 mm / 1.654 inches
Height from upper-edge of DIN-rail	32 mm / 1.26 inches
Depth	53 mm / 2.087 inches

Material data

Fire load	0.394 MJ
Weight	34.4 g

Commercial data

Product Group	6 (INTERFACE ELECTRONIC)
PU (SPU)	1 pcs
Packaging type	Box
Country of origin	US
GTIN	4017332462075
Customs tariff number	85369010000

Product Classification	
UNSPSC	39121421
eCl@ss 10.0	27-14-31-05
eCl@ss 9.0	27-14-31-05
ETIM 9.0	EC000635
ETIM 10.0	EC000635
ECCN	EAR99

Environmental Product Compliance	
RoHS Compliance Status	Compliant, No Exemption

Downloads

Environmental Product Compliance

Compliance Search	
Environmental Product Compliance 810-902/000-002	↓

Documentation

Bid Text			
810-902/000-002	19.02.2019	xml 3.44 KB	↓
810-902/000-002	05.03.2019	docx 16.69 KB	↓

CAD/CAE-Data

CAE data	
EPLAN Data Portal 810-902/000-002	↓
WSCAD Universe 810-902/000-002	↓

Subject to changes. Please also observe the further product documentation!

Current addresses can be found at: www.wago.com