



Flamco Pressurisation/Dosing/Degasser Equipment PressDS Plus

PressDS Plus Models (225, 250, 280)

Operation & Maintenance Manual

Rev 1.2



Customer Details

Please fill in information future reference:

Company:	<input type="text"/>	Contact:	<input type="text"/>
Address:	<input type="text"/>	Tel No:	<input type="text"/>
		Fax No:	<input type="text"/>
Post Code:	<input type="text"/>	E-mail:	<input type="text"/>

Equipment Details

Details of model and serial number may be found on the label

Model:	<input type="text"/>	Serial No:	<input type="text"/>
Purchase date:	<input type="text"/>	Purchase From:	<input type="text"/>
Additive Setting:	<input type="text"/>	Water Valve Setting:	<input type="text"/>

Note:

It is highly recommended to have this equipment commissioned by a Flamco approved engineer. Any damage or loss incurred through incorrect commissioning by an unapproved engineer will not be covered by the warranty. If you wish for Flamco to arrange this please contact us. (See contact details)

Please see the warranty section for details.

Remember to fill in details for future use for re-commission unit.

Commissioning Record

FILL IN RECORD TO VALIDATE WARRANTY OF PRESSURISATION UNIT

Pressurisation Controller			De-gassing Controller			
	As Found	On Completion		As Found	On Completion	
Cold Fill	<input type="text"/>	<input type="text"/>	Bar	Start Pressure	<input type="text"/>	Bar
High Set	<input type="text"/>	<input type="text"/>	Bar	Stop Pressure	<input type="text"/>	Bar
Low Set	<input type="text"/>	<input type="text"/>	Bar	Alarm Pressure	<input type="text"/>	Bar
Differential	<input type="text"/>	<input type="text"/>	Bar	Normal Minutes	<input type="text"/>	Mins
Flood Limit	<input type="text"/>	<input type="text"/>	Mins	Turbo Hours	<input type="text"/>	Hours
P1 Count	<input type="text"/>	<input type="text"/>		Timeout Minutes	<input type="text"/>	Mins
P1 Hours	<input type="text"/>	<input type="text"/>		Purge Seconds	<input type="text"/>	Secs
P2 Count	<input type="text"/>	<input type="text"/>		Pump Count	<input type="text"/>	
P2 Hours	<input type="text"/>	<input type="text"/>		Pump Hours	<input type="text"/>	
Alarm Count	<input type="text"/>	<input type="text"/>		Alarm Count	<input type="text"/>	
Power Interrupted	<input type="text"/>	<input type="text"/>		Power Interrupted	<input type="text"/>	
Pulse	<input type="text"/>	<input type="text"/>	Y/N	Pumps Sense	<input type="text"/>	Y/N
Excessive Start	<input type="text"/>	<input type="text"/>	Y/N	Turbo Mode	<input type="text"/>	Y/N
Service	<input type="text"/>	<input type="text"/>	Y/N	Service Reminder	<input type="text"/>	Y/N
Pump Number	<input type="text"/>	<input type="text"/>		ID Number	<input type="text"/>	
Pump Type	<input type="text"/>	<input type="text"/>				
Pump Sense	<input type="text"/>	<input type="text"/>	Y/N			
Sensor Type	<input type="text"/>	<input type="text"/>				
SPC Controller	<input type="text"/>	<input type="text"/>	Y/N			
Additive Unit	<input type="text"/>	<input type="text"/>	Y/N			
ID Number	<input type="text"/>	<input type="text"/>				
Relay Inversion	<input type="text"/>	<input type="text"/>	Y/N			
Overrun	<input type="text"/>	<input type="text"/>	Sec.			
HL Alarm AutoReset	<input type="text"/>	<input type="text"/>	Y/N			
Cascade	<input type="text"/>	<input type="text"/>				
Boost	<input type="text"/>	<input type="text"/>	Y/N			
Flomat	<input type="text"/>	<input type="text"/>	Y/N			
Expansion Vessel						
	As Found	On Completion				
Pre-charge	<input type="text"/>	<input type="text"/>	Bar			
Nominal Size	<input type="text"/>	<input type="text"/>	Litres			

**Commissioning certificate can be obtained
please contact Flamco representative**

Engineer Signature:
Date: / /

Customer Signature:
Date: / /

Contents

Customer & Equipment details	2
Commission Record	3
About this Manual	
Where to find more Information	5
Equipment Overview	
Principal of Operation	6 - 7
Installation	
Pipe Connections	8
Typical Installation Diagram	9
PressDS Clearance and Connection Requirements	10
Electrical Power Supply	11
Fault Contacts	12 - 13
Commissioning	
Pre-Commissioning Checklist	14
Controller Overview	15
Controller Programming	16
Program List	17 – 20
Hydraulic Commissioning	21 – 25
Balancing Valve Setting	26 – 27
Vacuum Cylinder	28
Operation	
Fault Codes	29 - 30
Shutdown Procedure	30
Start-Up Procedure	31
Maintenance	
Maintenance information	32 - 33
Wiring Diagram	34
Spares	
Electrical Items (All Models)	35
PressDS Models (225D, 250D, 280D)	36 - 38
Troubleshooting	39 - 42
Service Log	43 - 44
Warranty Information	45
Statement of Compliance	46

About this Manual

This Operation and Maintenance Manual contains all the necessary information to install, commission, operate and maintain Flexfiller pressurisation equipment.

It is recommended to read all parts of this manual before undertaking any work on the equipment.

Conventions used in this Manual

This manual makes use of symbols to identify key pieces of information. Please take note of the following symbols and their meaning:



DANGER – Important safety related information intended to prevent injury and/or damage to the equipment, system or property.



CAUTION - Important information intended to prevent damage to the equipment, system or property.



IMPORTANT - Important information intended to ensure that the equipment functions correctly.



USEFUL – Useful information which may be helpful, but is not necessarily required for the unit to function correctly.

Typography

This manual makes use of different typography to identify different types of information.

<i>Italics</i>	Key words and phrases
(Round Brackets)	Used to identify a button on the digital controller
[Square Brackets]	A parameter on the digital controller
<Inequality Symbols>	A message/fault code displayed on the digital controller

Where to find more Information

For further information please visit the Flamco Limited Website at the following URL:

www.flamco.co.uk

Alternatively, please contact the Flamco Limited head office using the details below:

Phone: 01744 744 744
Fax: 01744 744 700
Email: info@flamco.co.uk OR service@flamco.co.uk

Equipment Overview

The function of this pressurisation unit is to provide a means of automated water top-up to sealed heating and cooling systems. The equipment is designed to provide periodic water top-up to compensate for minor losses in system pressure (e.g. slow leaks, air venting, etc.).



This equipment is not designed to cope with sudden losses of system pressure (e.g. manual draining) or major water losses (e.g. large leaks). The equipment is also not intended to be used for water boosting applications.

Principal of Operation

The following schematic shows the internal arrangement of a pressurisation unit:

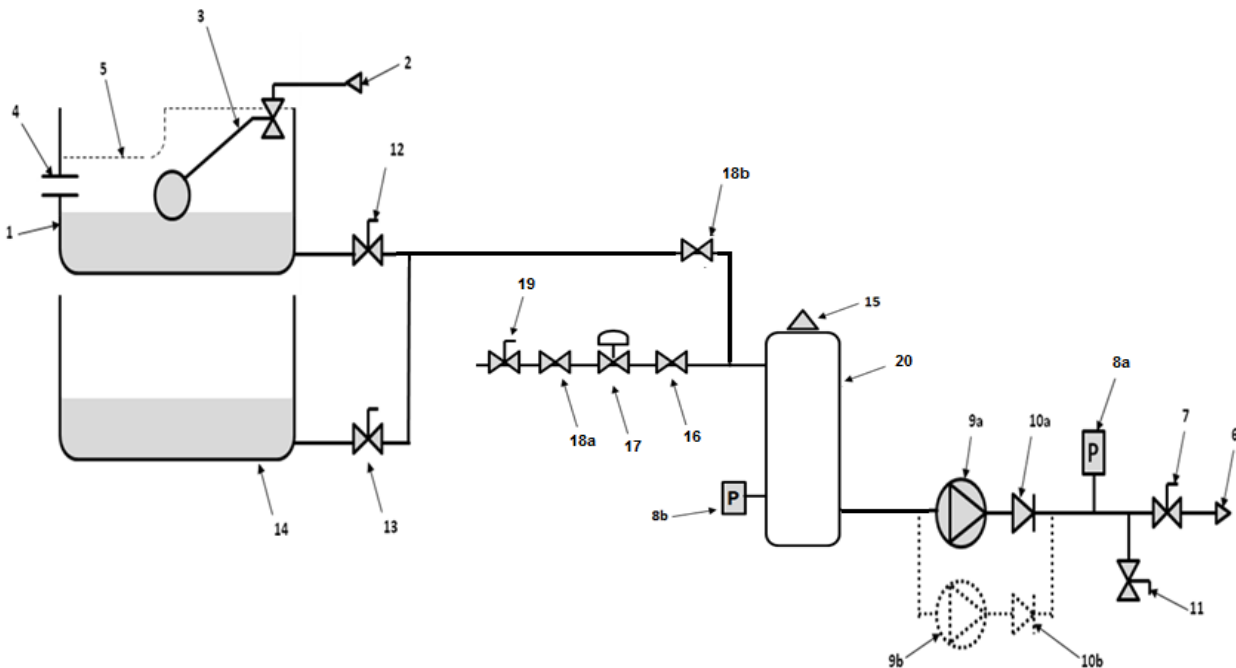

The PressDS Plus unit is fitted with a break tank (1) which is filled from the mains water supply (2) via a float operated valve (3). The break tank is fitted with an overflow (4) in case the break tank overfills, and a weir overflow (5) in case the primary overflow fails. Also fitted is an additive tank (14). Additive tank is filled with either Additive or additive, to add to the system a required mixture is required. To do this two balancing valves are placed after each of the tanks to control the mixture water (12) and Additive (13). (See mixture table)

Water is allowed into the Vacuum cylinder through a safety solenoid (18b), a pressure reducing valve (17) and a special variable bypass valve (16).

The pressure reducing valve (17) is used to limit the water held within the vacuum cylinder to approximately 1.2 bar. This is seen as the first pressure step.

When the vacuum cylinder is full and registering a suitable start pressure (8b) the pumps (9a/9b) activate. At the same time the special variable bypass valve (15) opens fully to allow the cylinder water to be completely flushed back into the system by the pumps (9a/9b). This purge cycle ensures that the maximum possible amount of aerated water will be exposed to the vacuum process.

After the vacuum cylinder has been refreshed, the variable bypass valve (16) restricts the flow into the vacuum cylinder. The pumps (9a/9b) continue to draw water out of the cylinder and create a vacuum within the cylinder. The pumps (9a/9b) then stop after a 5 second dwell period.

The vacuum created within the cylinder is eroded by the incoming water through the variable bypass valve (15) at a low flow rate, this gently increases the pressure within the cylinder and forces the released air pocket out through the Automatic Air Vent (AAV) on top of the cylinder.

The equipment is connected to the main system via 2 isolation valves (7a/7b) and backflow from the system is prevented by a non return valve (10a).

The integral pressurisation unit is fitted with a break tank (1) which is filled from the mains water supply (2) via a float operated valve (3). The break tank is fitted with an overflow (4) in case the break tank overfills, and a weir overflow (5) in case the primary overflow fails.

The break tank is connected into the degassing system via a solenoid valve (18b).

The pressure sensor (8a) monitors the system pressure.

If the pressure sensor detects a drop in pressure, the degassing controller will power down, the break tank solenoid (12) will open and the pump (9a) will pump water from the break tank (1) into the system. Once the required pressure has been reached, the pump will stop, closing the solenoid valve (18b) and restoring electrical power to the degassing controller.

On twin pump models, a second pump (9b) is provided. The two pumps will run in a duty/standby configuration (i.e. the active pump will alternate with each pump start).

The pump(s) are fitted with non-return valves (10a) to prevent backflow.

A drain valve (11) is provided for draining down the unit and for commissioning purposes.

Installation



This unit is not designed to be installed in an outdoor environment. The unit must be installed in a frost free environment, away from precipitation and water sprays/jets. If there is a risk of flooding, the unit must be installed on a raised plinth.



Please refer to the appropriate datasheet for the maximum working pressure and temperature of the pressurisation unit. The conditions at the point of connection to the system must not exceed these values.

Pipe Connections



Where applicable, to avoid damaging the float valve, the mains water supply pipe must be flushed before connection.



Degassing connections (2 off) to the return header must be made in the horizontal plane to prevent floating or heavy debris entering the pipework to this equipment.

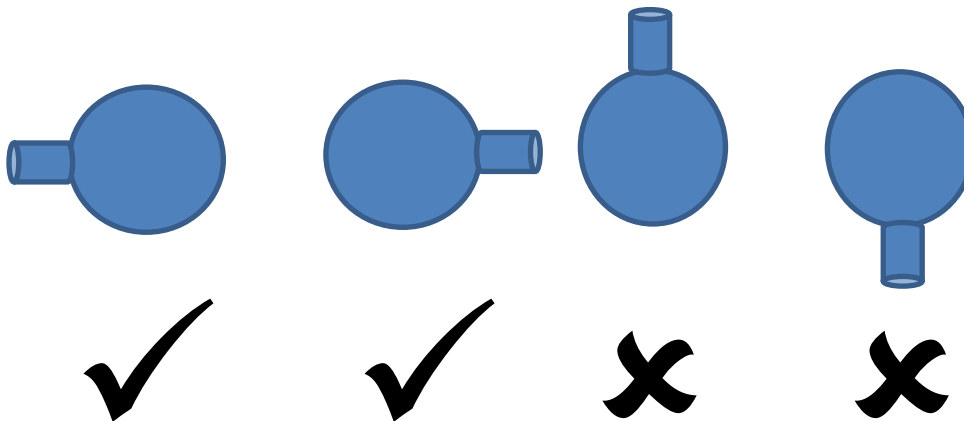

All pipe connections must be made with appropriate jointing compound/PTFE tape. If PTFE tape is used, care must be taken to ensure that the tape does not obstruct the orifice of the fitting.



Non-return valves, pressure reducing valves and RPZ valves must not be installed between this equipment and the heating/cooling system. These devices will prevent the pressure sensor from reading the system pressure.



The combined vacuum degassing and pressurisation unit and system expansion vessel should be connected to the system at the same point, to provide a neutral pressure reading. This point of connection should be in the system return, on the suction side of the circulation pump.

Typical Installation Diagram

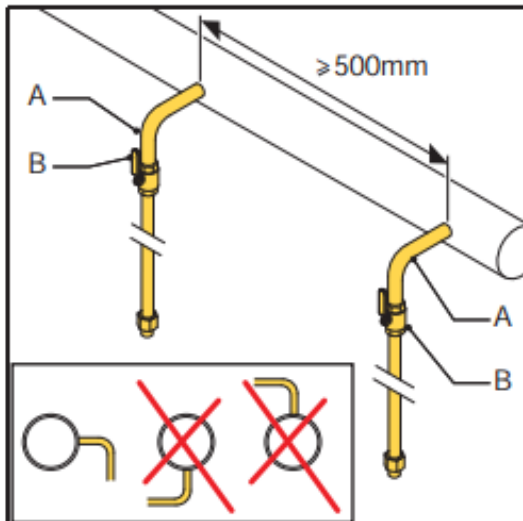
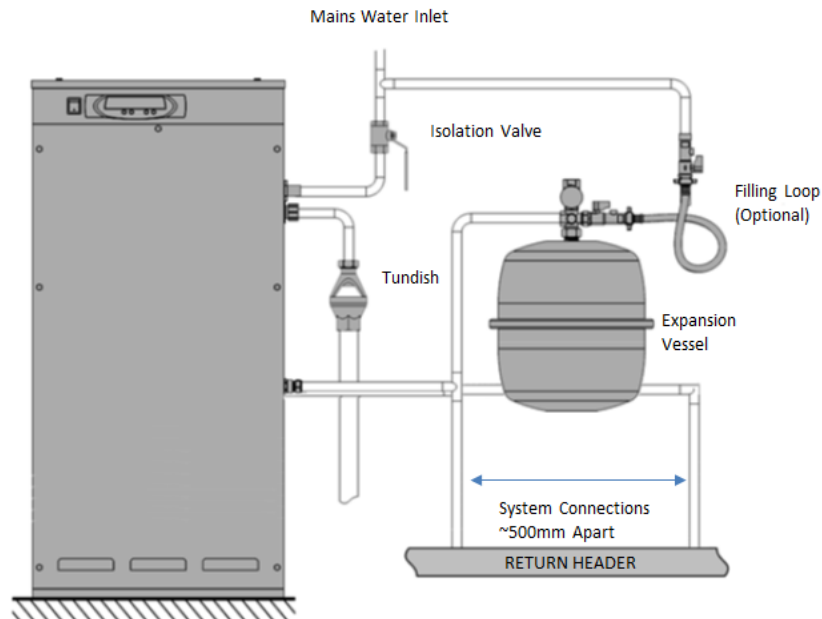

1. Make two branch lines 1/2" (A) on the side of the main transport line. The distance between them should be at least 500 mm.
2. Insert a valve (B) in each branch. With this the unit can be depressurised.

PressDS Plus Clearance and Connection Requirements

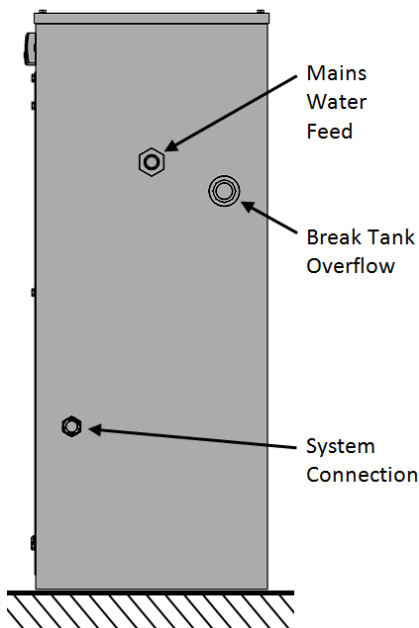
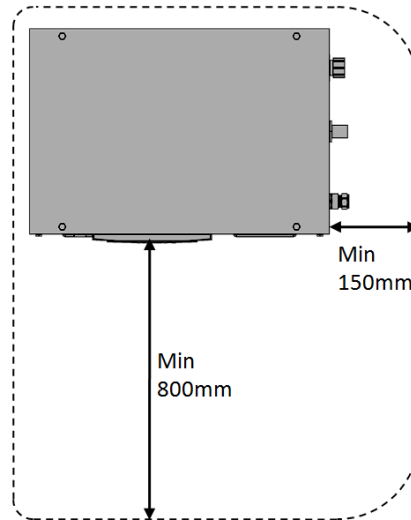
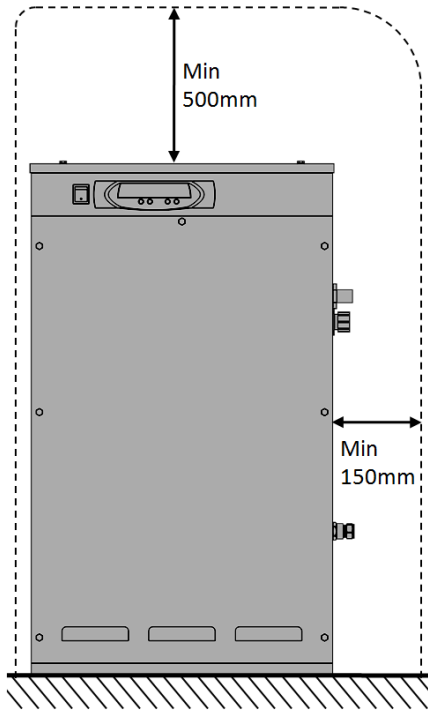

Connection	Size	Notes
Mains Water Feed	½" BSP M	An isolation valve must be installed on the mains water feed for servicing.
Break Tank Overflow	22mm	Guidance on drainage requirements should be obtained from the local water authority.
System Connection	½" BSP M / 15mm	<p>The pressurisation unit and expansion vessel should be connected to the system at the same point.</p> <p>The point of connection should be in the system return, on the suction side of the circulation pump.</p> <p>Non-return valves, pressure reducing valves and RPZ valves must not be used.</p>

Electrical Power Supply



This equipment must be electrically isolated before removing the covers. Cables connected to the volt free contacts may be supplied from another source and may remain live after the unit is isolated. These must be isolated elsewhere.



All electrical connections must be carried out by a suitably qualified and competent person.

The mains power supply to the pressurisation unit must be connected into the fused terminal block as shown below:

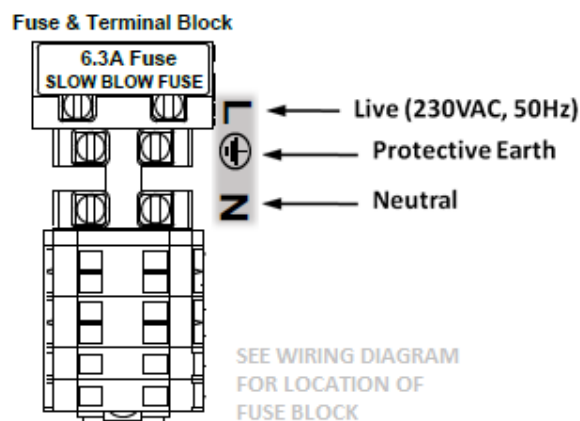

On some larger models, the fused terminal block is replaced by a fused spur. If this is the case, the power supply must be connected into the fused spur, as shown below:

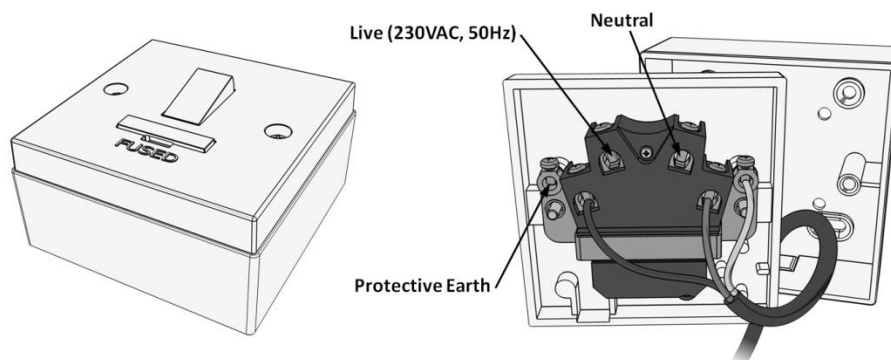

It is recommended to supply power to the pressurisation unit via a lockable isolator. This should be installed within 2m of the equipment.



This equipment can be damaged by the high voltages produced by electrical installation testing equipment. When performing electrical installation tests, the equipment must be isolated from the supply.

Micro Controller

Fault contacts

There are 6 volt free fault contacts which can be used for connection to a BMS system, or as a boiler interlock. These are terminals 1-12, located on the digital controller:

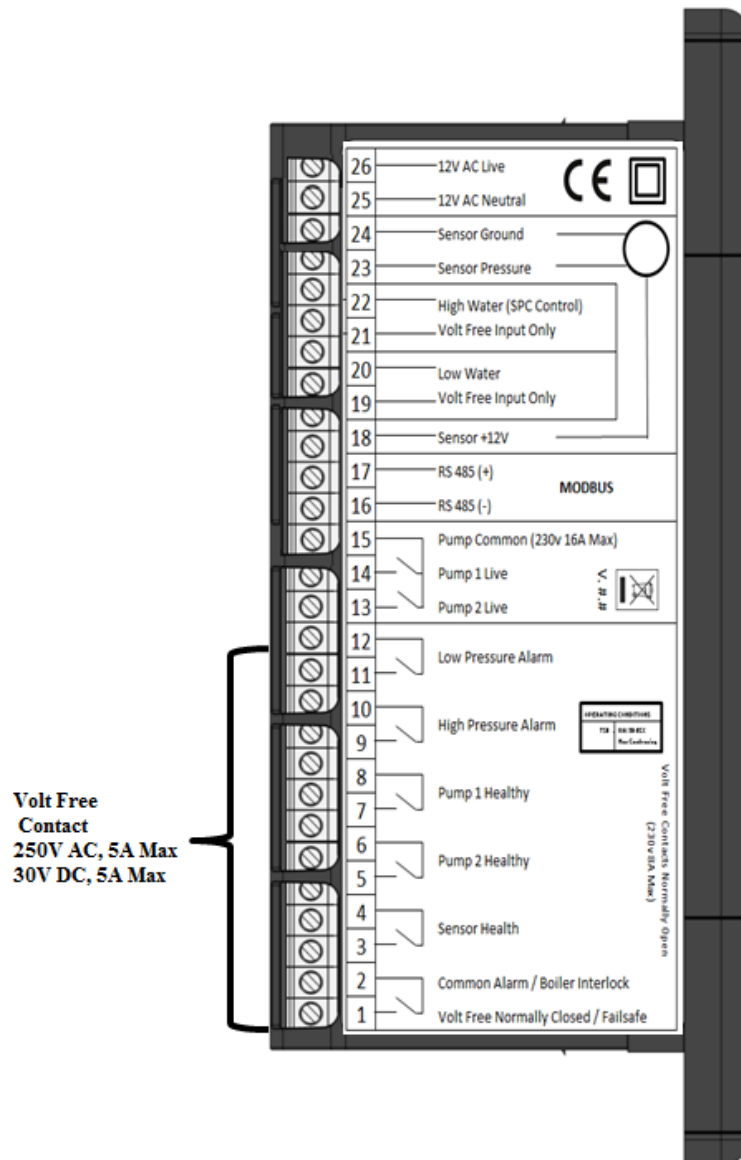

With the exception of the Common Alarm, it is possible to convert all other fault contacts to normally closed. For further information please refer to the commissioning section of this manual.

Fault Contacts Degasser Controller

There are 3 volt free fault contact which can be used for connection to a BMS system, or as an interlock. There is the Common Alarm contact on terminals 1&2, the Sensor Health contact on terminals 3&4 and the Pump Health contact on terminals 7&8.

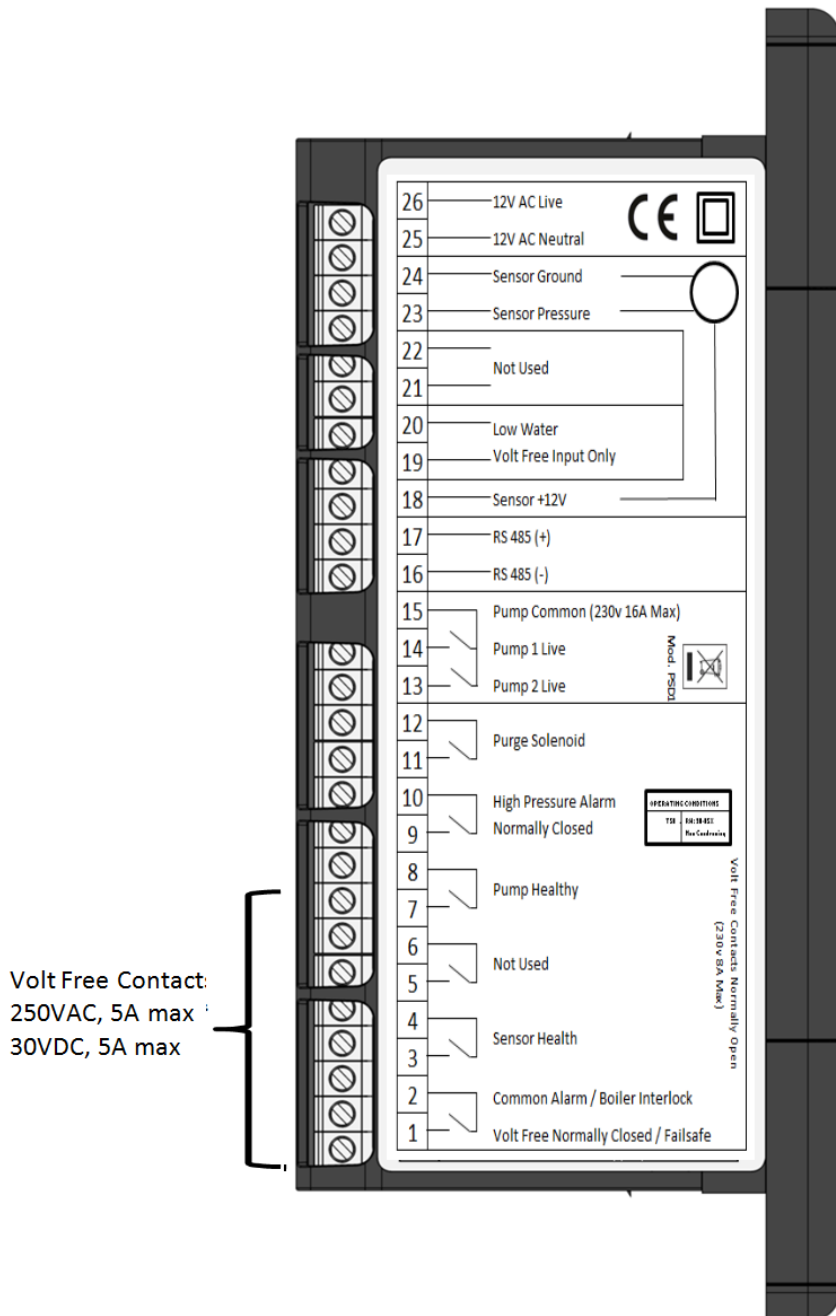

Commissioning



It is highly recommended to have this equipment commissioned by a Flamco approved engineer. Any damage or loss incurred through incorrect commissioning by an unapproved engineer will not be covered by the warranty.

Pre-Commissioning Checklist



The following conditions must be met before starting the commissioning process. Failure to meet these conditions may result in injury or damage to the equipment, system and property.

- Equipment is sited in a frost free area, away from precipitation and water sprays/jets
- All necessary pipe/electrical connections have been made to a satisfactory standard
- The temperature and pressure at the point of connection are within the operating limits of the pressurisation unit.
- The heating/cooling system is fitted with a safety valve and expansion vessel



The following conditions must be met for the pressurisation unit and heating/cooling system to function correctly. If these conditions have not been met, it is not advisable to proceed with the commissioning process.

- The system connection has been made into the system return header/pump suction
- There are no non-return valves, pressure reducing valves or RPZ valves installed between the pressurisation unit and the heating/cooling system
- The expansion vessel is pre-charged to the correct pressure (equal to fill pressure)



It is advisable to fill the heating/cooling system prior to commissioning. If this is not possible, the pressurisation unit can be used to fill the system after commissioning. Depending on the size of the system, this may take a considerable amount of time.

- The heating/cooling system is filled and pressurised to the required cold fill pressure, with the water at ambient temperature (approximately).

Controller Overview

The following image shows the front of the pressurisation unit digital controller. 4 buttons are provided for programming, and an LED display which shows scrolling messages.



When the controller is first powered up, it will display the controller version number. This manual relates to controller version >8.0. If the controller is of a different version, there may be differences in the menu items available.

When in normal operation, the controller will display the current system pressure. If a fault occurs, the controller will display a fault code and produce an audible alarm.

In normal operation, the functions of the buttons are as follows:

Button	Function	
	Press	Hold
SET	-	Show Current System Pressure
MUTE	Mute Audible Alarm	Reset Unit
+	-	Enter Programming Menu
-	-	Enter Programming Menu

Controller Programming



Do not alter any settings without first understanding the implications of doing so. Incorrect settings may cause damage to the equipment, system or property.

To enter the programming menu, hold the (+) button until “enter code” appears on the screen, followed by “0000” with a flashing cursor after the first digit.

To gain access to the programming menu, one of the following codes must be entered:

Customer Code	Standard set of options	2601
Engineer Code (≥V6.3)	Extended set of options	4706

To enter the code, change the first digit with the (+) and (-) buttons, then press (SET) to move onto the next digit. Repeat for all digits, then once the correct code is shown on the display, press (SET) to enter the programming menu.

Once a correct code has been entered, the first option [COLD FILL] will appear on the screen.

Once in the menu, the value of the current menu item can be changed using the (+) and (-) buttons. Once the current value has been set, pressing the (SET) button will move on to the next option.



It is not possible to navigate backwards through the menu. To return to a previous setting in the menu, press the (SET) button repeatedly to scroll through to the end of the menu, and then re-enter the appropriate code.



If the controller loses power while in the programming menu, all changes made will be erased. To confirm all changes, the end of the menu must be reached, and the “SAVING...” message must be displayed.

Note only the customer code works on the PSD controller. You do not need the engineers code.

Program List

The table below gives details of all menu items, in the order that they will appear:

#	Menu Item	Function	Default Value
1	COLD FILL	The required fill pressure, i.e. pump 'cut-out' pressure. The recommended setting is 0.3 BAR above the static pressure of the system (0.1 Bar per meter of static height). For example, a 14m high installation will have a static pressure of 1.4 Bar, making the recommended cold fill pressure 1.7 Bar. It is not possible to enter a value higher than the current [HIGH SET] or lower than the current [LOW SET] values.	1.0 Bar
2	HIGH SET	The high pressure alarm setting. If the pressure in the system reaches this value, the <HIGH PRESSURE> alarm and common alarm will be activated. The recommended setting is 10% below the safety valve rating. For example, if the safety valve rating is 3 Bar, the recommended setting is 2.7 Bar. It is not possible to enter a value lower than the current [COLD FILL] value.	2.7 Bar
3	LOW SET	The low pressure alarm setting. If the pressure in the system falls below this value, the <LOW PRESSURE> alarm and common alarm will be activated, and the pressurisation pumps will not run. The recommended setting is 0.5 Bar below the [COLD FILL] pressure. It is not possible to enter a value higher than the current [COLD FILL] value.	0.5 Bar
4	DIFFERENTIAL	The differential between the 'cut-in' and 'cut-out' pressures of the pressurisation pumps. The cut-in pressure will be equal to the [COLD FILL] pressure, minus the differential pressure. For example, if the [COLD FILL] pressure is set to 1.5 bar, and the differential set to 0.2 Bar, the pump 'cut-in' pressure will be 1.3 Bar ($1.5 - 0.2 = 1.3$)	0.2 Bar
5	FLOOD LIMIT	The maximum continuous run time for each of the pressurisation pumps. If a pump runs continuously for longer than this period, the pump will stop and a <FLOOD LIMIT> alarm will be activated. This is to prevent the unit from pumping large amounts of water in the event of a large leak/burst pipe. For very large systems, this may need to be increased. The value can be changed in increments of 10 minutes, to a maximum of 990.	10 MINS
6	PUMP 1 COUNT	The cumulative number of pump starts for pump 1. This is a cumulative counter, the value of which cannot be modified. If using the engineer's code, the counter can be reset to zero by holding the (MUTE) button.	-
7	PUMP 1 HOURS	The cumulative run time in hours for pump 1. This is a cumulative timer, the value of which cannot be modified. If using the engineer's code, the counter can be reset to zero by holding the (MUTE) button.	-

#	Menu Item	Function	Default Value
8	PUMP 2 COUNT	The cumulative number of pump starts for pump 2. This is a cumulative counter, the value of which cannot be modified. If using the engineer's code, the counter can be reset to zero by holding the (MUTE) button.	-
9	PUMP 2 HOURS	The cumulative run time in hours for pump 2. This is a cumulative timer, the value of which cannot be modified. If using the engineer's code, the counter can be reset to zero by holding the (MUTE) button.	-
10	ALARM COUNT	The cumulative number of all alarm incidents. This is a cumulative counter, the value of which cannot be modified. If using the engineer's code, the counter can be reset to zero by holding the (MUTE) button.	-
11	POWER INTERRUPTED	The cumulative number of power interruptions (i.e. controller turned off/ power cut). This is a cumulative counter, the value of which cannot be modified. If using the engineer's code, the counter can be reset to zero by holding the (MUTE) button.	-
12	PULSE	When enabled, if a pump has been inactive for 60 days, it will start and run for 2 seconds. This is to prevent the pumps from seizing.	YES
13	EXCESSIVE START	When enabled, if there are more than 3 individual pump runs within an 8 hour period, the unit will register an <EXCESSIVE DEMAND> alarm. Enabling this option may cause false alarms on some systems.	NO
14	SERVICE	When enabled, a service reminder will be displayed after 12 months from when the option was enabled. To reset the service reminder, set the value to 'NO' and exit the menu. Then, re-enter the menu and set the value to 'YES' again.	NO
15	FILL SYSTEM	When enabled, the <LOW PRESSURE> and <FLOOD LIMIT> alarms will be disabled, and pump 1 will run continuously for up to 24 hours until the cold fill pressure has been reached. Once the cold fill pressure has been reached, this option will automatically be deactivated, and the low pressure alarm and flood limit will be reactivated. This function is used to fill a system that is empty or at low pressure. Care must be taken using this option as the flood limit alarm is disabled, increasing the risk of flooding.	NO



If using the customer code, the menu will end at this point. After pressing (SET) once more, the controller will display "SAVING..." and return to normal operating mode. If using the engineer's code, additional menu items will be displayed.



The following settings are all pre-programmed in the factory and should not need to be modified on site. If these settings appear to have been reset, the most likely cause is a power spike. If this problem persists, a power filter may be required.



The following settings are for experienced engineers only. Incorrect configuration of these settings can cause the equipment not to function correctly, and may cause damage to the equipment, system or property.

#	Menu Item	Function	Default Value
16	PUMPS NUMBER	The number of pumps installed in the pressurisation unit.	2 or 1
17	PUMP TYPE	The type of pump installed in the pressurisation unit. There are two options, which are as follows: 0 – Centrifugal Pump (Flexfiller /Digifiller/ Midi) 1 – Piston Pump (mini units only)	0
18	PUMP SENSE	Disabling this option will stop the controller from monitoring the pumps and generating <PUMP FAIL> faults. It is not recommended to disable this option. Please consult Flamco Technical before doing so.	YES
19	SENSOR TYPE	The type of pressure sensor installed in the unit. There are two options which are as follows: 1 – 1-6V Output, 0-10 Bar Range 2 – 1-6V Output, 0-16 Bar Range	1
20	SPC CONTROLLER	Not required on standard Pressurisation unit	NO
21	GLYCOL	Enables the low Additive level switch. This option should only be enabled on Additive pressurisation units.	YES
22	ID NUMBER	A user configurable identification number. This option does not serve any functional purpose.	01
23	RELAY INVERSION	When enabled, all normally open fault contacts (i.e. all except the common alarm) are converted to normally closed.	NO
24	OVERRUN	Allows the pump to continue running for a set period of time after the required pressure has been reached. This will prevent the pumps from ‘hunting’. The value can be set from 0 – 10 seconds.	5
25	PRESSURE ALARM AUTO RESET	When enabled, the <HIGH PRESSURE> and <LOW PRESSURE> alarms will be cleared automatically if and when the pressure returns to normal. If disabled, the alarms must be manually reset.	YES
26	CASCADE	Allows the pumps to operate in duty/assist mode. After either pump starts, the other pump will start after a set period of time. This option can be set to OFF, or 5 – 30 seconds.	OFF
27	BOOST	When enabled, the controller will allowing the pumps to run even if the system pressure is zero.	YES
28	SOLENOID CONTROLLER	When enabled, the “high water” input is used to trigger a top up solenoid valve connected to the “sensor healthy” volt free contact. This option should only be enabled on units which utilize a solenoid valve as the means of top-up.	NO

Note:

21 = ADDITIVE UNIT / 28 = FLOMAT ON (>7.3 VERSION CONTROLLER)

Degasser Controller

The table below gives details of all menu items, in the order that they will appear:

#	Menu Item	Function	Default Value
1	Start Pressure	Internal Safe Pressure Within The Vacuum Cylinder For The Pumps To Start Circulating Water	1.0 Bar
2	Stop Pressure	Internal Stop Pressure For The Pumps, Required Vacuum Pressure	-0.7 Bar
3	Alarm Pressure	Internal High Pressure Alarm Setting, To Activate The Slamshut Solenoid Valve	4.5 Bar
4	Normal Minutes	Normal Interval Between Pump Runs (Degassing)	60 MINS
5	Turbo Hours	Running Time For Turbo Mode Before Returning To Normal	168 HRS
6	Timeout Minutes	Time Limit For Vacuum Generation Or Restoration Of Internal Pressure (Error Checking)	10 MINS
7	Purge Seconds	Time Setting For Water To Be Re-circulated Into The Main System, Taking A Fresh Sample	20 SEC
8	Pump Count	Pump Activation Counter (Logging)	-
9	Pump Hours	Pump Cumulative Hours Run Counter (Logging)	-
10	Alarm Count	Cumulative Alarm Counter (Logging)	-
11	Power Interrupted	Cumulative Power Off Counter (Logging)	-
12	Pump Sense	Disabling this option will stop the controller from monitoring the pumps and generating <PUMP FAIL> faults. It is not recommended to disable this option. Please consult Technical Support before doing so.	Y
13	Turbo Mode	Activation Option For Turbo Mode (Commissioning Setup)	Y
14	Service	12 Month Service Reminder	Y
15	ID Number	Protocol ID Number	55



If using the customer code, the menu items 12 and 15 are not displayed.



The above settings are all pre-programmed in the factory and should not need to be modified on site with the exception of the 'Purge Seconds' setting which is system dependent. If these settings appear to have been reset, the most likely cause is a power spike. If this problem persists, a power filter may be required.

Purge Seconds Reference Times

Main System Pressure	Purge Time
1.0 to 3.5 bar	20 seconds
3.5 to 5.0 bar	30 seconds
5.0 to 6.0 bar	40 seconds
6.0 to 7.0 bar	60 seconds
7.0 to 8.0 bar	120 seconds

Hydraulic Commissioning

1 – Float Valve Setting

Ensure that the break tank float valve is set to its lowest position:

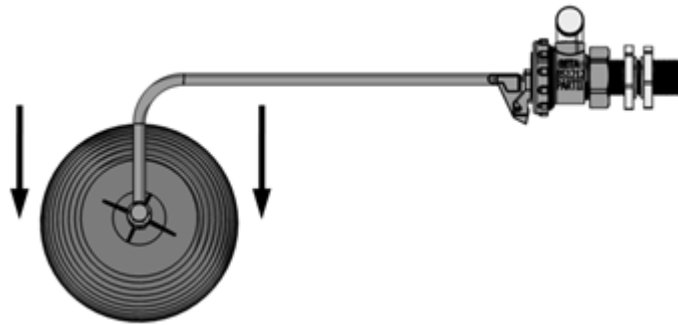

PressDS Units

If a drain valve is fitted to the break tank, ensure that it is closed. Then, turn on the mains water supply and allow the break tank to fill.



When the float valve operates for the first time, it may not close immediately, causing the break tank to overfill. Once the internals of the valve have been fully wetted this should not occur again.

2 – Bleeding Pumps



Make sure that the internal isolation valve within the pressurisation unit is closed by following the steps below. Failure to do this may cause injury or damage to the equipment, system or property.

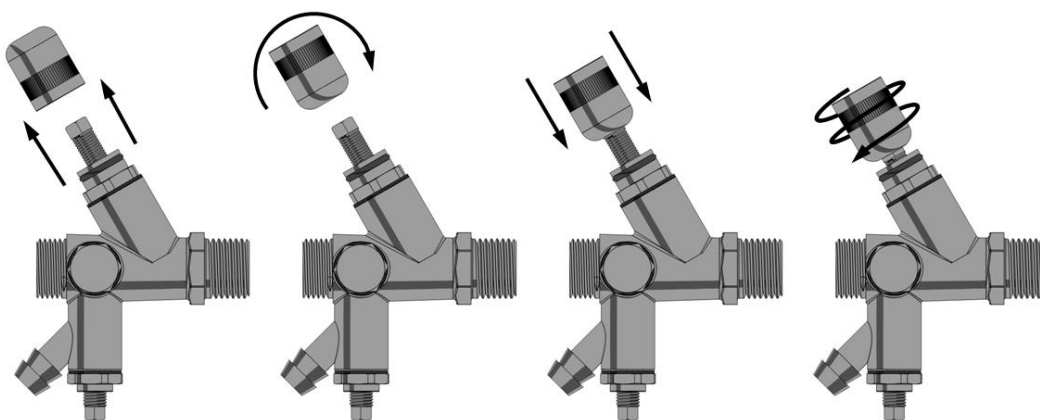

Un-screw cap

turn cap

push cap on socket

Twist cap

Attach a length of hose to the hose tail on the drain valve and put the other end to drain. Then, using the cap off the isolation valve, open the drain valve:

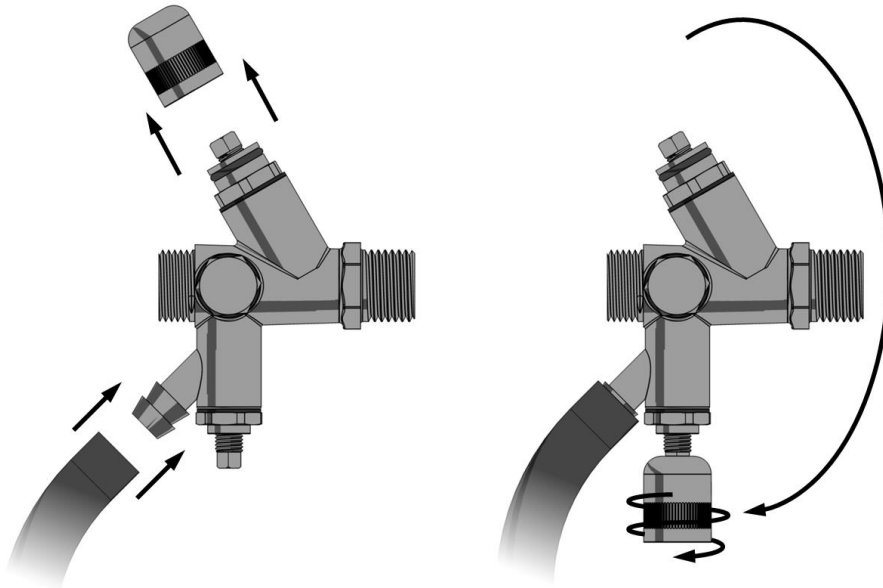

Locate the bleed screw on the pump. The following diagrams show examples of typical bleed screw locations for most pumps:

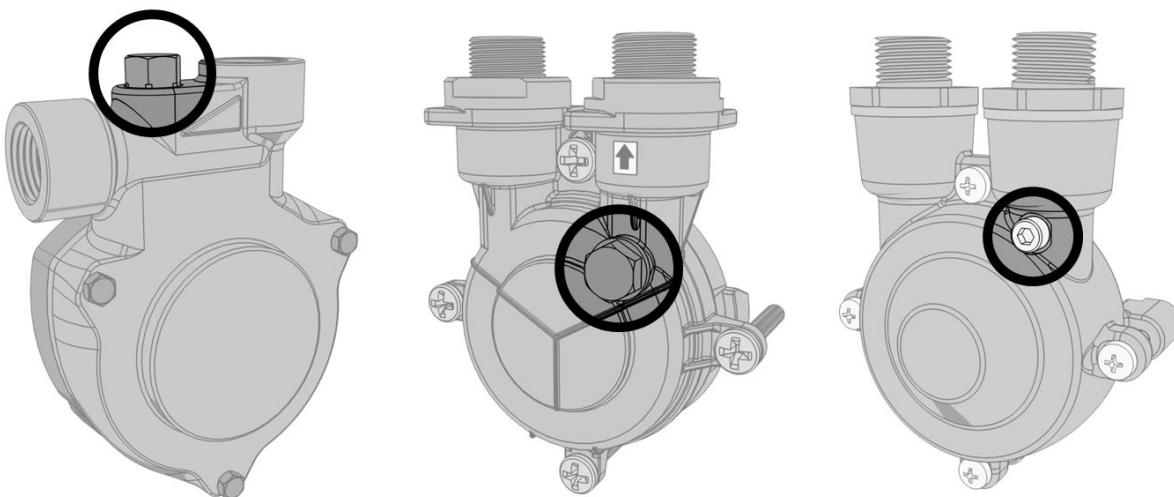

Do not use excessive force when tightening the bleed screw as this may damage the pump casing.



If the pump has a plastic bleed screw like the one shown below, do not use excessive force or attempt to use any tools to turn it as this may damage the pump casing.

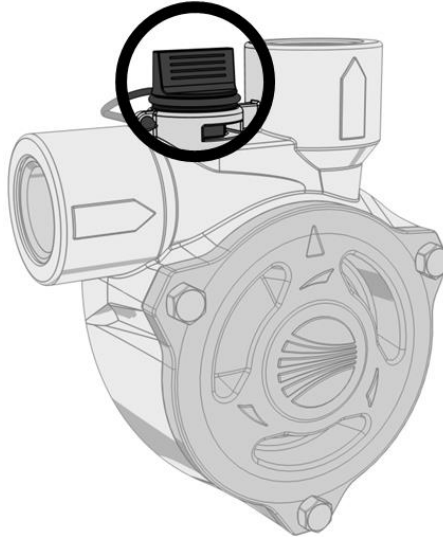

Forcing Pumps to Run



Turn on the power supply to the digital controller and wait for the system pressure to appear on the display. Then, enter the code 2601 and go to the first setting in the menu, cold fill. While at this point in the menu, holding down the (MUTE) button will force pump 1 to run, and holding down the (SET) button will force pump 2 to run.



If the controller is older than V6.1 then there is no way to force pump 2 to run via the controller. To force the second pump to run, the unit must be isolated and the live wires in terminals 13 and 14 must be swapped over. The second pump then becomes “pump 1” and can be forced to run via the controller.



To bleed the pumps, the pumps must be started. Then while the pump is running, the bleed screw must be opened until all the air has been removed and only water is being discharged. The bleed screw can then be closed.



Failure to bleed the pumps may result in damage to the equipment, system and property.



After bleeding the pumps, close the drain valve and remove the hose from the hose tail.

3 – Initial Start-up

Open the internal isolation valve within the pressurisation unit by following the steps below:

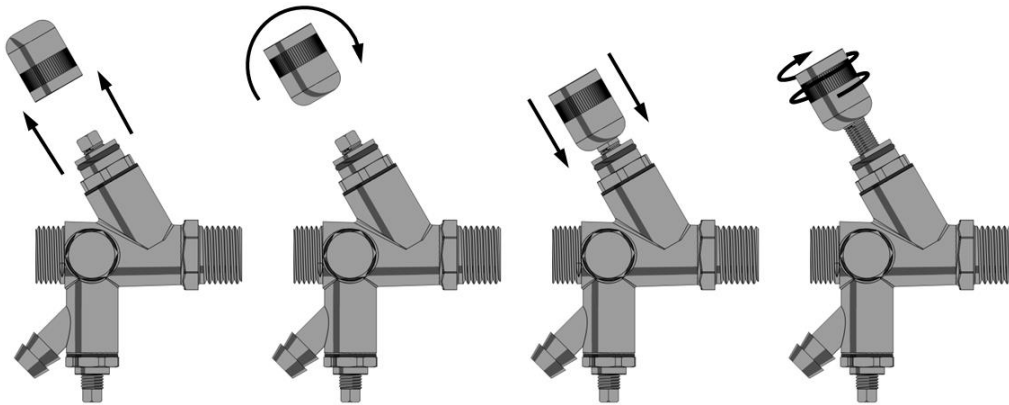

PressDS

Once the isolation valve is open, the pressure sensor will be able to read the system pressure.

Turn on the power supply to the pressurisation unit. Depending on the current system pressure, the unit will respond in one of the following ways:



If the system pressure is below the low pressure alarm setting, the controller will display a “LOW PRESSURE” fault and the pumps will not run. To clear this fault, either increase the system pressure using a filling loop, or enable the system fill option on the pressurisation unit.



If the system pressure is above the high pressure alarm setting, the controller will display a “HIGH PRESSURE” fault. To clear this fault, use a suitable drain point to remove water from the system until the system pressure equals the cold fill pressure.



If the system pressure is above the low pressure alarm setting, but below the cold fill setting (by an amount equal to the differential setting), the pumps will start. Once the system pressure has reached the cold fill pressure, the pump will stop.

Once the required system pressure has been reached, the controller will display the current system pressure. The unit is now in normal operation.

4 – Testing

To test the operation of the pressurisation unit while connected to the system, the system pressure must be lowered slowly to simulate a minor leak.

This can be achieved by using a drain point on the system, the drain point on the pressurisation unit, or by manually opening the safety relief valve.



Care must be taken not to let the pressure drop too quickly. If the system pressure falls below the low pressure set point, a low pressure fault will be displayed and the pumps will not run. The pressurisation unit is not designed to cope with a sudden loss of system pressure, which would be symptomatic of a catastrophic failure such as a burst pipe.

Once the system pressure has fallen below the cold fill setting (by an amount equal to the differential setting), the pump should start refilling the system. The pump will continue to run until the cold fill pressure has been reached.

This test demonstrates the primary function of the pressurisation unit. This test may be repeated at any time to confirm the operation of the pressurisation unit.

Balancing Valve Setting

Open and Close

Indicator shows:
 White = Open Valve
 Red = Closed Valve

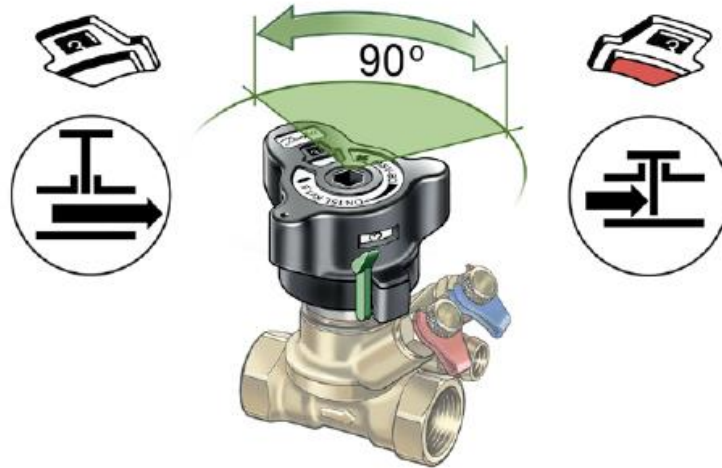

Setting the Flow

- Move green lever
- Handle will pop up
- Turn to set flow rate
- Push/Click to lock

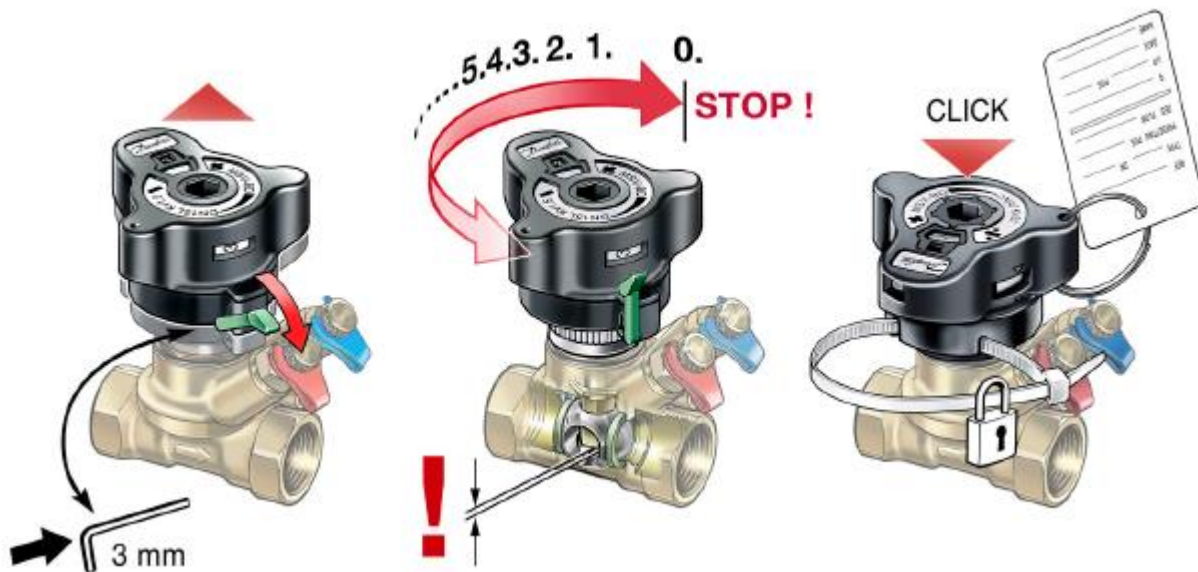

Notes

- In locked position (handle down) valve operates as a ball valve
- Clockwise to close (Red)
- Anti Clockwise to open (white)
- Fluid will not flow whilst red bar is showing. Note green release lever will not function whilst valve is closed (red)

The following table shows the valve settings required to achieve a given Additive concentration.

Additive %	Total Top-up Rate	H ₂ O Valve	Additive Valve
1	6 Litres	6-0	0-2
10	6 Litres	6-0	1-2
15	6 Litres	6-0	1-8
20	6 Litres	6-0	2-0
25	8 Litres	5-8	2-6
30	8 Litres	5-6	2-8
35	8 Litres	5-4	3-2
40	8 Litres	5-0	3-7
45	8 Litres	4-8	3-9
50	8 Litres	4-6	4-6

Additive Control

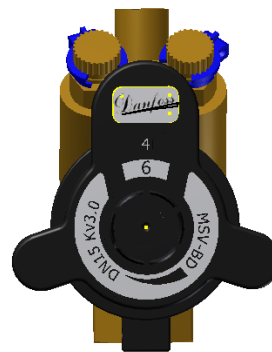

Water Control

Key:

- 1 = Water Tank (4 Litre)
- 14 = Additive Tank
- 12 = Water Balancing Valve
- 13 = Additive Balancing Valve

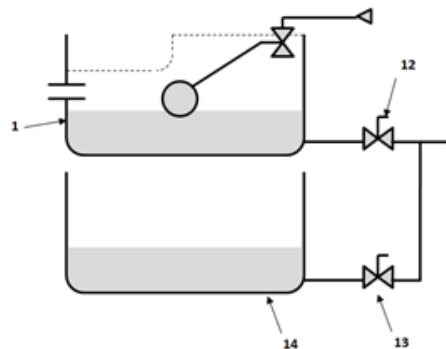

Hydraulic Commissioning

1- Venting The Vacuum Cylinder

Check the red cap on the air intake preventer is finger tight.



Do not unscrew the red cap completely. Inside is a glass bead and spring that prevent air being drawn into the equipment at this point. Without the spring and the beads this device will not function correctly and the equipment as a whole will be unusable.

With the equipment electrically powered down remove the coil from the two Inlet solenoids

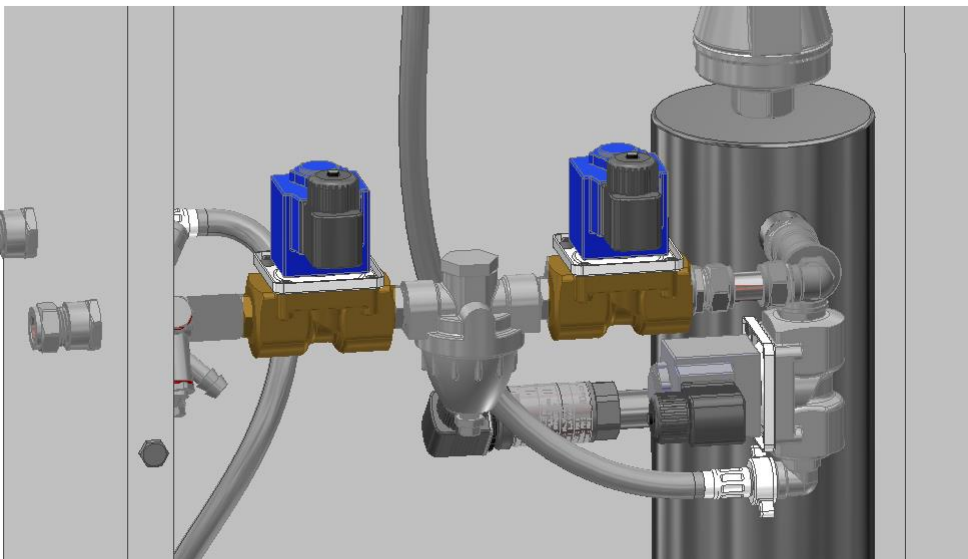

Be careful not to mix up the coils when disconnected. Failure to pair the correct coil with the correct valve will stop the unit from working.

With the coils disconnected use a pair of Danfoss override magnets (not supplied, available from Danfoss stockists under the 018F0091 part number) to manually open both of the solenoid valves. This allows the existing system pressure to fill the vacuum cylinder for the first run.

Remove the override magnets, return the correct coil to the correct valve and electrically switch the unit on. If the pressure shown on the degasser display is below the start pressure of the equipment it may be necessary to adjust the pressure reducing valve in between the two inlet solenoids. A setting on the pressure reducing valve 0.2 to 0.4 bar higher than the start pressure is acceptable, any lower than this and the equipment may become intermittent in operation.



If the Danfoss magnets are not available then it is possible to vent the cylinder through the internal 1mm bypass, although this may take a considerable amount of time. The alternative to this is to temporarily put live power directly to the solenoid coils to force the valves to open

Operation

Once commissioned, the pressurisation unit should operate without any user intervention.

Under normal operating conditions, the display will show the current system pressure in Bar.

While the unit is filling, the display will show <PUMP 1 RUN> or <PUMP 2 RUN> depending on which pump is currently running.

If the unit identifies a fault, the display will show the relevant fault code.



If the pressurisation unit is showing a fault code on the display, holding down the [SET] button will cause the current system pressure to be temporarily shown on the display.

Topup Fault Codes

The following table gives the meanings of all fault codes used on the digital controller:

Fault Code	Description	Auto/Manual Reset
LOW PRESSURE	The system pressure is below the [LOW PRESSURE] set point.	User Defined
HIGH PRESSURE	The system pressure is above the [HIGH PRESSURE] set point.	User Defined
LOW H2O	The break-tank low level float switch has been activated	Auto Reset
HIGH H2O	The break-tank high level float switch has been activated	Auto Reset
P1 FAIL	The controller has detected a fault (incorrect current draw) on the respective pump	Manual Reset
P2 FAIL		
P1 FLOOD LIMIT	The respective pump has run for longer than the [FLOOD LIMIT] period	Manual Reset
P2 FLOOD LIMIT		
ERR. 1	The signal from the pressure sensor is out of range	Manual Reset
EXCESSIVE DEMAND	There have been 4 pump starts within an 8 hour period	Manual Reset
SERVICE	The pressurisation unit is due an annual service	Manual Reset



For practical guidance on diagnosing and rectifying faults, please refer to the Troubleshooting section of this manual.

Degassing Fault Codes

Fault Code	Description	Auto/Manual Reset
Error	Incorrect password (Code) entered.	Auto Reset
High Pressure	High system pressure, audible alarm sounds. The Safety Solenoid closes. This alarm will self reset when the system pressure returns to normal, audible alarm can be silenced by pressing "mute".	Auto Reset
Insufficient Vacuum	The low water switch has been activated, either a leak has occurred or the air non return valve has failed or is missing.	Manual Reset
Pump FAIL	Pumps have failed, the pump failure relay closes. The boiler interlock opens, the audible alarm sounds.	Manual Reset
Timeout	Either the pumps have run for too long or the pressure has not reached the required start pressure for the pump within the time limit. Check the internal filter on the PRV and the solenoid valves for obstruction.	Manual Reset
Service	The unit has been in service for 12 months and a routine inspection is due (User option in menu).	Manual Reset

Shutdown Procedure



The pressurisation unit must be shut-down during any of the following scenarios:

- Work is being carried out on the system.
- Work is being carried out on the pressurisation unit
- The heating/cooling system is being flushed

To shut down the equipment, please follow the steps below:

1. Isolate the electrical power supply to the unit
2. Isolate the mains water supply to the unit (Combined equipment only)
3. Isolate the unit from the system using the isolation valves
4. If it is anticipated that the unit will be out of commission for more than 24 hours, it is advisable to drain the water from the break tank (Combined equipment only)

Start-Up Procedure



Attention – This procedure is for restarting the unit after being shutdown (as described above). For initial start-up and commissioning procedures, please refer to the Commissioning section of this manual.

To restart the unit, please follow the steps below:

1. Perform a visual inspection of the unit and installation to check for signs of damage
2. Check the break-tank for debris/deposits and remove if necessary (Combined equipment only)
3. Turn on the mains water supply to the pressurisation unit and allow the break tank to fill (Combined equipment only)
4. Open the isolation valves
5. Turn on the mains power supply and wait for the controller to start
6. Depending on the conditions in the system, the unit may display one or more fault codes at this point. If this happens, please refer to the Troubleshooting section of this manual for guidance.

Maintenance

Due to variations in operating conditions, and the varying loads placed on pressurisation units, it is not feasible to provide accurate predictions of component lifespan. The most effective method of maintenance is to inspect the pressurisation unit for early signs of component failure and take action accordingly.

The following maintenance procedures should be performed at least once a year:

Visual Inspection

A basic visual inspection will highlight the majority of potential faults on a pressurisation unit. It is recommended to perform a visual inspection annually. However, due to the simplicity of performing these checks, frequent inspections are encouraged.

- Check the digital display for fault codes
- Check for signs of leakage (e.g. water, mineral deposits, corroded components/cabinet)
- Check the break tank overflow for signs of water discharge
- Check flexible hoses for signs of degradation (e.g. cracks)
- Check that the pressure reading on the digital display corresponds to the actual system pressure (read off another gauge)

Interrogate Controller

The digital controller keeps a log of the number of pump starts and total hours run for each pump, as well as the number of alarm activations and power interruptions. It is advisable to take a note of these figures when servicing the unit, as they may be helpful in diagnosing potential issues. Fields are provided in the service log for these figures.

It is advisable to scroll through all the settings (including engineers setting) and check them against the figures on the commissioning report. If there are any discrepancies, check first with on-site staff to see if the changes are deliberate. If not, reconfigure appropriately.



If settings are persistently becoming corrupted, a power filter may be required. Please refer to the Installation section of this manual for more information.

Test Unit Operation

The best way to test the operation of the pressurisation unit is to drain water from the system, allowing the pressure to drop slowly. Once the pressure falls below the pump cut-in pressure ([COLD FILL] – [DIFFERENTIAL]) the pump should start. As soon as the pump starts, close the drain point and allow the system pressure to rise. Once the [COLD FILL] pressure is reached, the pump should stop.

If the unit is a twin pump model, this test should be repeated until both pumps have run and successfully re-pressurised the system.

Check Float Valve Operation

To test the operation of the break tank float valve, first ensure that the break tank overflow has a suitable path to drain.

Gently push down on the arm of the float valve until it starts to discharge water, then release the float valve arm. Once the arm has been released, the flow of water should stop within a few seconds.

Check Float Switch Operation

To test the operation of the break tank low level float switch, reach into the break tank and gently push the float switch down into the horizontal position.

The digital controller should now display a <LOW H2O> fault.

Release the float switch and observe the display. The fault should clear after a delay of a few seconds.

Check Break Tank Water Condition

Perform a visual check of the water in the break tank. If there is any dirt or debris in the water, or deposits on the sides of the tank, the tank should be drained down and cleaned.

Check Strainer (Flexfiller units only)

Flexfiller pressurisation units are fitted with a mesh strainer in the connection at the bottom of the break tank. This should be removed and inspected. Depending on the condition, this part may need to be cleaned or replaced.

Check Expansion Vessel Pre-Charge

Many of the problems experienced with pressurisation equipment can be traced back to the expansion vessel.

The expansion vessel pre-charge pressure must be checked after 2 years and annually thereafter.

To perform this test, the expansion vessel must first be drained of water, then a gauge can be connected to the Schrader valve on the vessel to measure the pre-charge pressure. The pre-charge should be equal to the [COLD FILL] pressure setting.

The pressure can be increased using a foot pump, air compressor or pressurised air/nitrogen cylinder.



If any faults are identified during these checks, please refer to the Troubleshooting section of this manual. If replacement parts are required, please refer to the Spares section for part codes.

Wiring diagram

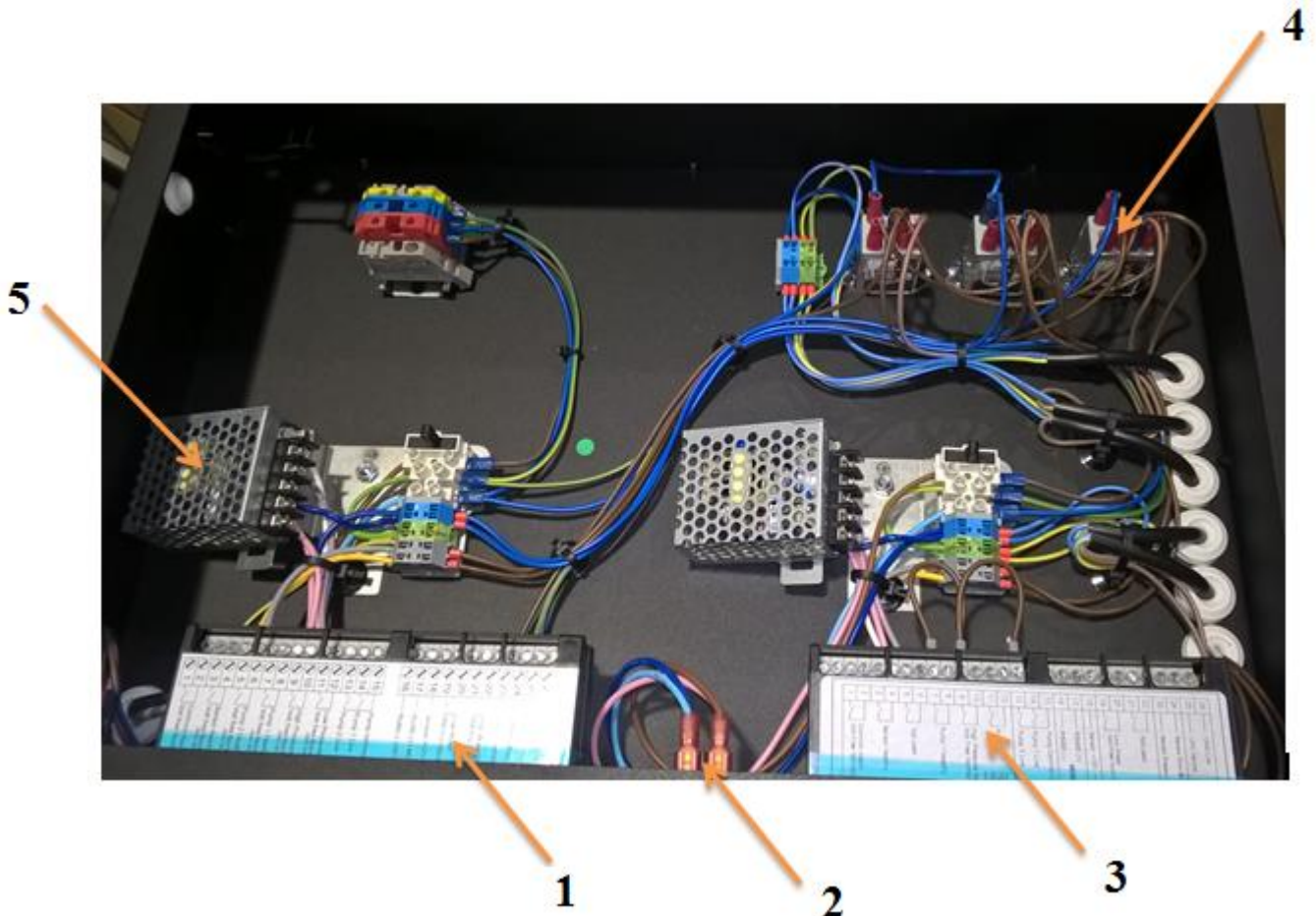

#	Description
1	Digital Controller – Standard Pressurisation
2	Power Switch
3	Digital Controller - Degasser
4	Relay switches (x3)
5	Electrical Plate (Fuse Block and 15V PSU)

Spare Parts



The drawings on the following pages show the internal components for a range of pressurisation equipment. Due to continuing development and minor design changes, some components may be changed without notice. Therefore, the drawings may not accurately reflect the current production design. If in any doubt about the compatibility of replacement parts, please contact Flamco.

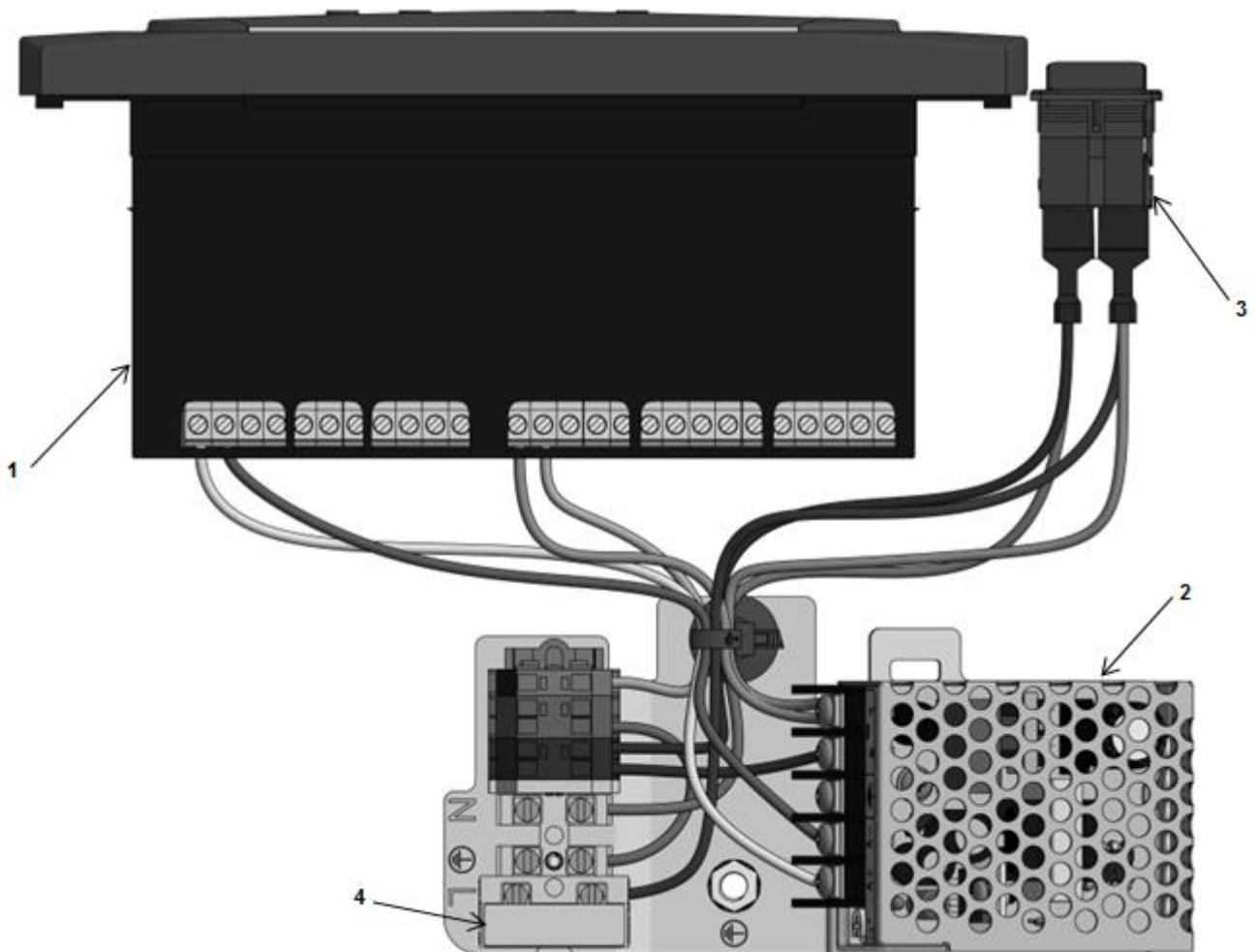

*Image for indication only

Kit No	Kit Description	ID	Part Description	Qty
STA12502	Controller (PressDS PLUS) Spares Kit	1	CONTROLLER	1
		1	PSD CONTROLLER	1
		2	ELECTRICAL PLATE TWO PUMP	2
		3	ON/OFF SWITCH	2

ID Number (4) is included with part of Electrical plate as standard, this rated at 6.3 Amp

PressDS Models (250, 250, 280)

Top section of unit

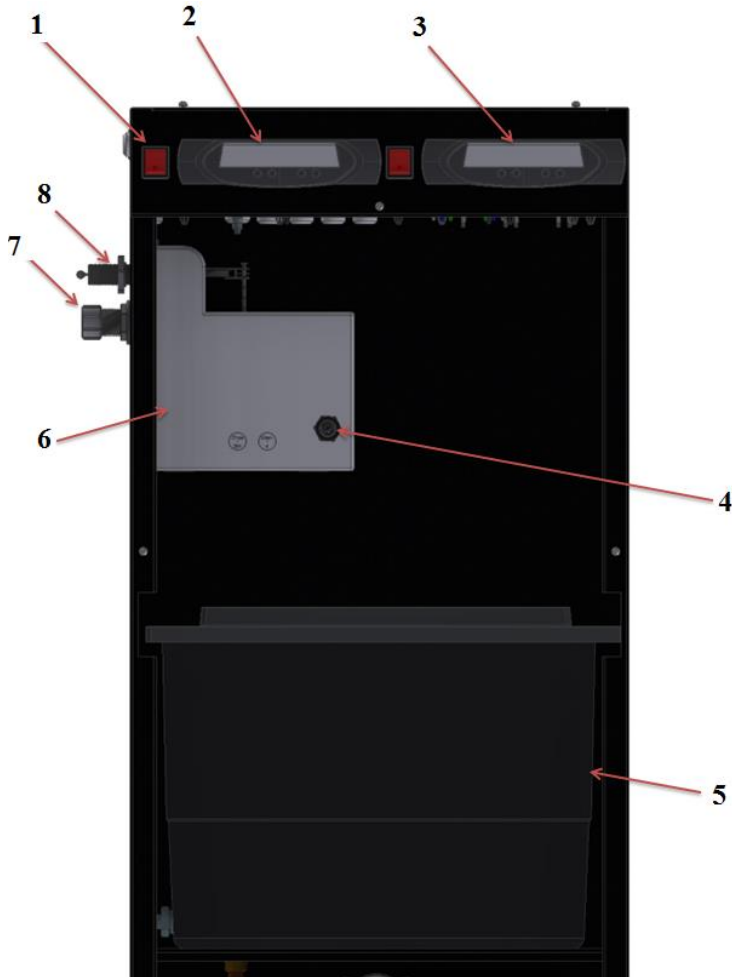

Spare Parts List:

Kit No	Kit Description	ID	Part Description	Qty
STA12528	Break Tank Spares	4	LOW LEVEL FLOAT SWITCH	1
		*	15MM X 1/2 FLG TANK CONN	2
		*	1/2 PILLAR WASHER	2
		8	FLOAT VALVE	1
		7	OVERFLOW CONNECTION	1

Bottom section of unit

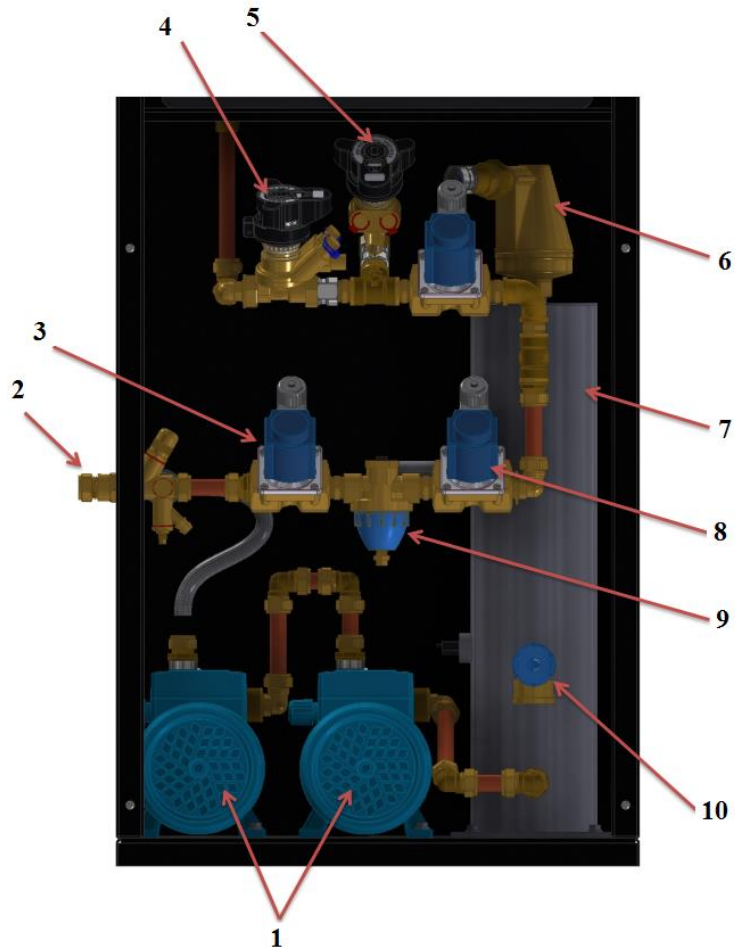

Spare Parts List:

Kit No	Kit Description	ID	Part Description	Qty
STA12514	2 Pump Replacement Kit (50m)	1	PQ81B PUMP	2
STA12515	2 Pump Replacement Kit (80m)	1	PQA90 PUMP	2
Following parts are also included in the 2 Pump Replacement Kit		*	1/2 NON- RETURN VALVE	2
		*	1/2 X 15 MM MALE COUPLING	4
		*	FLEXIBLE HOSE	4
		*	15MM X 15MM X 15MM TEE	1
		*	15 MM COPPER TUBE	50 MM
		*	RING CRIMP	2
		*	0.75 MM CABLE BLACK	2.06
		STA12516	2 Pump Replacement Kit (160m)	1
*	NRV 16 BAR ½ FF			2
*	COUP 15mm x 1/2 BSpt			2
*	1/2 Brass Nipple			1
*	1.5 MM WHT 4-CORE CABLE			4 m
*	Elbow 15mm x 1/2 BSpt M			2
STA12531	Isolation and Sensor Kit (PN16)	2	COMB ISOLATION AND DRAIN	1
		*	TRANSDUCER	1
		*	FLG LOCKNUT 1/2	1
STA12532	Isolation and Sensor Kit (PN10)	2	COMB ISOLATION AND DRAIN	1
		*	TRANSDUCER	1
		*	FLG LOCKNUT 1/2	1
STA12535	Balancing Valve Kit	*	1/2 X 1/4 REDUCING BUSH	1
		*	8 MM X 1/4 M ADAPTOR	1
		*	1/2 NON- RETURN VALVE	2
		*	1/2 HEX BRASS NIPPLE	2
		*	1/2 BRASS TEE	1
		*	1/2 X 15MM MALE COUP	1
		*	1/2 X 15MM MALE ELB	1
		*	8 MM PLASTIC TUBE	1 MTR
		4 / 5	DN15 Venturi Balancing Valve	2

(*) these parts are not shown

Troubleshooting

If for any reason the pressurisation unit does not seem to be functioning correctly, please refer to the table below for a list of solutions to known problems.



If the pressurisation unit is showing a fault code on the display, holding down the [SET] button will cause the current system pressure to be temporarily shown on the display.

Symptom	Problem	Solution
LOW PRESSURE fault is displayed and the pumps do not run	The internal isolation valve within the unit is closed	Open the internal isolation valve
	The system pressure has fallen below the LOW PRESSURE set point	Increase system pressure using a filling loop, or enable the SYSTEM FILL option
	The SPC CONTROLLER option is enabled	Disable the SPC CONTROLLER option
	The LOW PRESSURE set point is too high	Review the system specifications
HIGH PRESSURE fault is displayed	The internal isolation valve within the unit is closed	Open the internal isolation valve
	The system pressure has risen above the HIGH PRESSURE set point	Decrease system pressure using a suitable drain point
	The expansion vessel has failed or lost its pre-charge	Check the expansion vessel pre-charge and re-charge if necessary
	The expansion vessel is undersized	Review the expansion vessel selection
	The HIGH PRESSURE set point is too low	Review the system specifications
P1 and/or P2 FLOOD LIMIT is displayed	A large amount of water has been lost from the system	Investigate cause
	The relevant pump is air-locked and not pumping water	Bleed the pump
	The unit is undersized for the system	Review unit selection
	The FLOOD LIMIT time is too short.	Consult Flamco

Symptom	Problem	Solution
P1 and/or P2 FAIL is displayed	The PUMP TYPE option is set incorrectly.	Review PUMP TYPE setting
	The relevant pump has failed	Replace pump
P2 FAIL is displayed but the unit is a single pump model	The PUMPS NUMBER option is incorrectly set to 2	Set PUMPS NUMBER to 1
LOW H2O fault is displayed	The mains water supply to the unit has been isolated	Turn on the mains water supply
	The mains pressure is poor	The fault will clear once the break tank has been re-filled
	A non-standard electrical connection has been made into terminals 19 & 20	Remove all non-standard electrical connections
	The low water float switch has failed	Replace low water float switch
	The digital controller has failed	Replace digital controller
HIGH H2O fault is displayed	A non-standard electrical connection has been made into terminals 21 & 22	Remove all non-standard electrical connections
	The digital controller has failed	Replace digital controller
Pressure reading does not match actual system pressure.	The internal isolation valve within the unit is closed	Open the internal isolation valve
	The SENSOR TYPE option is set incorrectly	Review SENSOR TYPE setting
	A non-return valve has been installed between the unit and the system	Remove non-return valve
	The pressure sensor has failed	Replace pressure sensor
ERROR 1 fault is displayed	The SENSOR TYPE option is set incorrectly	Review SENSOR TYPE setting
	The pressure sensor has failed	Replace pressure sensor
Pump runs but does not make up pressure	The pump is air-locked and not pumping water	Bleed the pump

Symptom	Problem	Solution
The break tank is overfilling and discharging water to drain or over the weir	The float valve position is set incorrectly	Set the float valve to its lowest possible position
	The float valve has failed	Replace float valve
	A pump non-return valve has failed	Replace non-return valve
The pump is repeatedly running in short bursts	The internal isolation valve within the unit is partially closed	Fully open the internal isolation valve
	The restriction in the connecting pipe work is too great	Increase bore/ reduce number of bends/ reduce length of connecting pipe work
	A pump non-return valve has failed	Replace non-return valve
	The expansion vessel has failed or lost its pre-charge	Check the expansion vessel pre-charge and re-charge if necessary
	The point of connection of the unit is too far away from the expansion vessel	Move unit/expansion vessel connection points closer together.
The buttons on the digital controller do not respond	The plastic housing of the digital controller has come apart and the PCB has moved	Reassemble the digital controller housing and ensure that the PCB is properly seated
The digital controller parameters are being corrupted	The controller is being subject to power spikes	Fit a suitable power filter
The digital controller does not power up when the unit is switched on	The fuse has blown	Replace the fuse
	The mains power supply is at an incorrect voltage or frequency	Check mains power supply
	The 12V transformer has failed	Replace Transformer
	The digital controller has failed	Replace digital controller
SERVICE is displayed on the screen	The unit is due an annual service	Contact service engineer

If for any reason the degassing side of the unit does not seem to be functioning correctly, please refer to the table below for a list of solutions to known problems.

Symptom	Problem	Solution
High Pressure	The internal pressure within the vacuum cylinder has reached the high pressure alarm limit, probably due to the pressure reducing valve being contaminated with debris.	The safety solenoid valve will automatically close and the system will attempt to self-reset during the next degassing cycle. Repeated High pressure alarms will require the pressure reducing valve to be inspected and cleaned.
Insufficient Vacuum	The Vacuum cylinder is full of air and the low level switch is stopping further pump activation to prevent the pump(s) running dry. There is an air leak on the cylinder, the bypass solenoid is contaminated with debris or the air intake preventer is contaminated with debris	Clean the air intake preventer, and test the unit. If this fails then check the bypass solenoid and pipework for contamination. Finally replacing the automatic air vent assembly is the best course of action.
Pump FAIL	The pump is drawing either too much current or not enough, signifying a mechanical/electrical failure.	Check the controller settings first to ensure that the correct pump is being monitored, alternatively replace the pump.
Timeout (1)	The vacuum cylinder has not been able to return to the start pressure in the allotted time	Check the bypass solenoid valve is not blocked (1 mm bypass hole), replace if required. Check the setting on the pressure reducing valve and the internal filter of the pressure reducing valve.
Timeout (2)	The required vacuum has not been generated in the allotted time	Check the pump operation and that the system pressure is within the operational pressures of the equipment. Replace the Pump as required. Check the bypass solenoid is functioning correctly and closing after the purge cycle.

Service Logs

This service log should be completed by the service engineer after each annual service.

Date		P1 COUNT	
Engineers Name		P1 HOURS	
Company		P2 COUNT	
Contact Number		P2 HOURS	
		ALARM COUNT	
		POWER INTERUPTIONS	
Comments			
Date		P1 COUNT	
Engineers Name		P1 HOURS	
Company		P2 COUNT	
Contact Number		P2 HOURS	
		ALARM COUNT	
		POWER INTERUPTIONS	
Comments			
Date		P1 COUNT	
Engineers Name		P1 HOURS	
Company		P2 COUNT	
Contact Number		P2 HOURS	
		ALARM COUNT	
		POWER INTERUPTIONS	
Comments			
Date		P1 COUNT	
Engineers Name		P1 HOURS	
Company		P2 COUNT	
Contact Number		P2 HOURS	
		ALARM COUNT	
		POWER INTERUPTIONS	
Comments			



Date		P1 COUNT	
Engineers Name		P1 HOURS	
Company		P2 COUNT	
Contact Number		P2 HOURS	
		ALARM COUNT	
		POWER INTERRUPTIONS	
Comments			

Date		P1 COUNT	
Engineers Name		P1 HOURS	
Company		P2 COUNT	
Contact Number		P2 HOURS	
		ALARM COUNT	
		POWER INTERRUPTIONS	
Comments			

Date		P1 COUNT	
Engineers Name		P1 HOURS	
Company		P2 COUNT	
Contact Number		P2 HOURS	
		ALARM COUNT	
		POWER INTERRUPTIONS	
Comments			

Date		P1 COUNT	
Engineers Name		P1 HOURS	
Company		P2 COUNT	
Contact Number		P2 HOURS	
		ALARM COUNT	
		POWER INTERRUPTIONS	
Comments			

Warranty Details

Warranty - What Is Covered?

The Flamco warranty on equipment supplied to distribution and OEM covers manufacturing defects, under our standard terms and conditions of sale.

If the unit is identified with a manufacturing defect then no charge is made for correcting the defect.

The Flamco equipment is manufactured to order and is clearly marked, where applicable, with a unique serial number, allowing traceability to both individual model configuration and the engineer or site responsible for the build and test.

Warranty - What Is Not Covered?

If a defect or problem has arisen as a direct result of the connected system, misuse, incorrect handling, incorrect installation or incorrect commissioning then any service visit is chargeable.

If a defect is identified as a manufacturing defect it will be addressed as described above, additional remedial works as a result of misuse, incorrect handling, incorrect installation or incorrect commissioning then the additional work is chargeable.

Installation costs and/or consequential losses are not covered by this agreement.

Conditions of warranty

DOS - Date Of Supply

DOC - Date Of Commissioning

Equipment	Conditions	Timescale
Flamco Pressurisation Equipment inc PSD & Flamcomat	That there is an appropriate safety valve on the system protecting the equipment. That the equipment is undamaged at the time of installation. That the equipment is not exposed to adverse environmental conditions. That the equipment is stored and installed in a frost free area. That the operating and maintenance instructions are followed. That the equipment is used for the purpose for which it was designed.	18 months DOS 24 months DOC

Contact Details

Please send form back this form using the address below, if you any queries please use contact below.

Phone: +44 (0)1744 744 744

Fax: +44 (0)1744 744 700

Email: info@flamco.co.uk (General Enquires)

Email: service@flamco.co.uk (Service Enquires)

STATEMENT OF COMPLIANCE

Manufacturer Flamco Limited
Washway Lane
St Helens
Merseyside
WA10 6PB
United Kingdom

Product: Flamco Pressurisation & Vacuum Degasser Equipment and branded Derivatives

Statement:

The above-mentioned products are manufactured in The UK and comply with the essential requirements of the applicable directives, including but not limited to:

Pressure Equipment Directive	2014/68/EU
Sound Engineering Practice	
RoHS Compliance	

Additional Information:

All appropriate components bear the CE mark prior to assembly, and are bound by their individual applicable directives including but not limited to:

Pressure Equipment Directive	2014/68/EU
Low Voltage Directive	2014/35/EU
Electromagnetic Compatibility Directive	2014/30/EU
Machinery Directive	2006/42/EC

CE Marking:

Under the regulations and guidelines CE marking of the assembled pressurisation unit is not permitted.

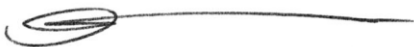

Rob Clemson BEng Hons MIET Chartered Engineer
Technical Director
Flamco Limited



Flamco

Your reliable partner



Flamco Limited

Washway Lane
St. Helens
Merseyside WA10 6PB
United Kingdom

T +44 1744 744 744
F +44 1744 744 700
E info@flamco.co.uk



www.flamcogroup.com