

Wilo-Drain TM/TMW/TMR 32



en Installation and operating instructions



Drain TM/TMW/TMR 32
<https://qr.wilo.com/701>

Table of contents

1	Safety	4
1.1	About these instructions	4
1.2	Identification of safety instructions.....	4
1.3	Personnel qualifications.....	4
1.4	Fluids hazardous to health.....	4
1.5	Personal protective equipment.....	4
1.6	Transport and storage	5
1.7	Installation	5
1.8	Electrical connection	5
1.9	During operation	5
1.10	Removal.....	5
1.11	Clean and disinfect	5
1.12	Operating fluid	6
2	Product description	6
2.1	Description.....	6
2.2	Technical data	7
2.3	Type key	7
2.4	Scope of delivery.....	7
2.5	Functions.....	7
3	Application/use	7
3.1	Intended use	7
3.2	Improper use.....	8
4	Transport and storage	8
5	Installation and electrical connection	8
5.1	Installation types.....	8
5.2	Installation	8
5.3	Electrical connection	9
6	Commissioning	10
6.1	Before activating.....	10
6.2	Switching on and off	10
6.3	Test run	10
6.4	Drain TMR flat suction.....	11
6.5	During operation	11
7	Removal	11
7.1	Stationary wet well installation	11
7.2	Portable wet well installation.....	11
8	Cleaning	11
8.1	Clean pump	11
8.2	Removing and cleaning the strainer.....	12
8.3	Removing and cleaning the turbulator	12
9	Maintenance	12
9.1	General overhaul	12
10	Faults, causes and remedies	12
11	Spare parts	13
12	Disposal	13
12.1	Information on the collection of used electrical and electronic products.....	13

1 Safety

1.1 About these instructions

These instructions form part of the product. Compliance with the instructions is essential for correct handling and use:

- Read the instructions carefully before all activities.
- Keep the instructions in an accessible place at all times.
- Pass the instructions on to a subsequent owner.
- Observe all product specifications.
- Observe the markings on the product.

The language of the original operating instructions is German. All other languages for these instructions are translations of the original operating instructions.

Failure to observe the instructions will result in danger to persons or damage to property. The manufacturer is not liable for damage caused by:

- Improper use.
- Incorrect operation.

1.2 Identification of safety instructions

In these installation and operating instructions, safety instructions are displayed as follows:

- **Danger to persons:** Safety instructions are **preceded by a corresponding symbol** and are shaded in grey.
- **Damage to property:** Safety instructions start with a signal word and are displayed **without** a symbol.

Signal words

- **DANGER!**
Failure to follow the instructions will result in serious injuries or death!
- **WARNING!**
Failure to follow the instructions can lead to (serious) injury!
- **CAUTION!**
Failure to follow the instructions can lead to potentially irreparable property damage.
- **NOTICE!**
Useful information on handling the product

Symbols

These instructions use the following symbols:



Danger caused by electric voltages



Danger of explosion



Warning – risk of cuts and similar injuries



Personal protective equipment: wear protective gloves



Personal protective equipment: wear mouth protection



Personal protective equipment: wear safety goggles



Useful information

1.3 Personnel qualifications

- Persons aged 16 and over
- Have read and understood the installation and operating instructions

Children and persons with limited abilities in the household

This device can be used by children from 8 years of age as well as people with reduced physical, sensory or mental capacities or lack of experience and knowledge if they are supervised or instructed on the safe use of the device and they understand the dangers that can occur. Children are not allowed to play with the device. Cleaning and user maintenance must not be carried out by children without supervision.

1.4 Fluids hazardous to health

In stagnant water (e.g. pump sump, soakaway, etc.) germs which are hazardous to health can form. There is a danger of bacterial infections!

- Clean and disinfect the product thoroughly after removal!
- Inform all persons about the pumped fluid and the danger it poses!

1.5 Personal protective equipment

The aforementioned branded products constitute non-binding suggestions. Similar products from other brands can also be used. WILO SE

does not assume any liability for the aforementioned products.

Protective equipment: Transport, installation, removal and maintenance

- Safety shoes: uvex 1 sport S1
- Protective gloves (EN 388): uvex phynomic wet

Protective equipment: Cleaning work

- Protective gloves (EN ISO 374-1): uvex pro-fapren CF33
- Safety goggles (EN 166): uvex skyguard NT
- Breathing protection mask (EN 149): Half mask 3M series 6000 with filter 6055 A2

1.6 Transport and storage

- Wear protective equipment!
- Always carry the product by the handle!
- Clean product and disinfect if necessary!
 - Dirt fosters the formation of germs.
 - Encrustations may lead to the impeller becoming blocked.

1.7 Installation

- Wear protective equipment!
- Do not install damaged or defective products.
- If there is a risk of germ formation, observe the following points:
 - Ensure sufficient air exchange.
 - Wear a breathing protection mask e.g. Half mask 3M series 6000 with filter 6055 A2

1.8 Electrical connection

- Do not connect products with a damaged connection cable! Have the connection cable replaced by a qualified electrician or the customer service.
- Mains connection with correctly installed protective earth conductor.
- Install the residual-current device (RCD) with 30 mA.
- Fuse protection at mains connection: max. 10 A.
- **Product without plug:** Electrical connection must be carried out by a qualified electrician!

1.9 During operation

- The pumping of highly inflammable and explosive fluids (petrol, paraffin, etc.) in their pure form is strictly prohibited!
- If persons come into contact with the pumped fluid (accessible basins*), do not commission the product.

***Definition of “accessible basins”**

Installation sites that can be walked on and directly accessed without tools (examples below):

- Garden ponds
- Swimming ponds
- Cesspools

NOTICE! The specifications applicable to swimming pools also apply to accessible basins.

1.10 Removal

- Wear protective equipment!
- **Product without plug:** Have the connection cable disconnected from the mains by a qualified electrician.
- Depending on the operating mode and duration, the housing parts become hotter than 40 °C (104 °F).
 - Only touch the product by the carrying handle.
 - Allow product to cool down.
- Clean the device thoroughly.
- If there is a risk of germ formation, observe the following points:
 - Ensure sufficient air exchange.
 - Wear a breathing protection mask e.g. Half mask 3M series 6000 with filter 6055 A2
 - Disinfect product.

1.11 Clean and disinfect

- Wear protective equipment!
The protective equipment prevents contact with germs that are hazardous to health and the disinfectant.
- If a disinfectant is used, follow the manufacturer's instructions!
 - Wear protective equipment according to the manufacturer's instructions! If in doubt, ask your specialist dealer.

- Inform all persons about the disinfectant and how to use it correctly!

1.12 Operating fluid

The oil is located in the sealing chamber. It serves to lubricate the seal on the motor and pump side.

- Absorb leakages immediately.
- If major leakages occur, contact customer service.
- If the seal is defective, the oil enters the pumped fluid and the sewer.
- Collect waste oil by type (unmixed) and dispose of it in accordance with regulations at a certified collection point.
- **Skin contact:** Rinse skin areas thoroughly with soap and water. If skin irritation occurs, consult a doctor.
- **Contact with eyes:** Remove the contact lenses. Rinse eye thoroughly with water. If eye irritation occurs, consult a doctor.
- **Ingestion:** Consult a doctor immediately! Do not induce vomiting!

2 Product description

2.1 Description

Submersible pump for stationary and portable wet well installation. Pump with fitted float switch for fully automatic operation.



Fig. 1: Overview

1	Handle
2	Pressure connection
3	Pump housing
4	Strainer
5	Float switch (not TM 32/8-10M)
6	Connection cable

Drain TM

Sewage pump with open multi-channel impeller and vertical threaded connection. Pump housing, strainer and impeller made of composite material. 1~ motor (jacket cooling) with integrated operating capacitor and self-switching thermal motor monitoring. Stainless steel motor housing. Oil-filled sealing chamber with double sealing: a rotary shaft seal is installed on the motor side, a mechanical seal on the pump side. Connection cable with float switch and fitted plug (CEE 7/7).

Drain TMW

Sewage pump with integrated turbulator (twister function), open multi-channel impeller and vertical threaded connection. Pump housing, strainer and impeller made of composite material. 1~ motor (jacket cooling) with integrated operating capacitor and self-switching thermal motor monitoring. Stainless steel motor housing. Oil-filled sealing chamber with double sealing: a rotary shaft seal is installed on the motor side, a mechanical seal on the pump side. Connection cable with float switch and fitted plug (CEE 7/7).

The twister function guarantees permanent turbulence within the pump's intake area. The turbulence prevents the settling sediments from sinking and settling. This ensures a clean pump sump and reduces the build-up of odours.

Drain TMW ... HD

Sewage pump with integrated turbulator (twister function), open multi-channel impeller and vertical threaded connection. Pump housing, strainer and impeller made of composite material. 1~ motor (jacket cooling) with integrated operating capacitor and self-switching thermal motor monitoring. Motor housing and shaft made of high-quality stainless steel (AISI 316L). Oil-filled sealing chamber with double sealing: a rotary shaft seal is installed on the

motor side, a mechanical seal on the pump side. Connection cable with float switch and fitted plug (CEE 7/7).

The twister function guarantees permanent turbulence within the pump's intake area. The turbulence prevents the settling sediments from sinking and settling. This ensures a clean pump sump and reduces the build-up of odours.

Drain TMR

Sewage pump with depth suction (pumping out up to 2 mm residual water level), open multi-channel impeller and vertical threaded connection. Pump housing, strainer and impeller made of composite material. 1~ motor (jacket cooling) with integrated operating capacitor and self-switching thermal motor monitoring. Stainless steel motor housing. Oil-filled sealing chamber with double sealing: a rotary shaft seal is installed on the motor side, a mechanical seal on the pump side. Connection cable with float switch and fitted plug (CEE 7/7).

Drain TM 32/8-10M

Sewage pump with open multi-channel impeller and vertical threaded connection. Pump housing, strainer and impeller made of composite material. 1~ motor (jacket cooling) with integrated operating capacitor and self-switching thermal motor monitoring. Stainless steel motor housing. Oil-filled sealing chamber with double sealing: a rotary shaft seal is installed on the motor side, a mechanical seal on the pump side. Connection cable with fitted plug (CEE 7/7), **without** float switch.

2.2 Technical data

Date of manufacture	See rating plate ¹⁾
Mains connection	See rating plate
Rated power	See rating plate
Max. delivery head	See rating plate
Max. volume flow	See rating plate
Activation type	See rating plate
Speed	See rating plate
Discharge connection*	TM 32: G 1¼ AG, TMW/TMR 32: G 1¼ IG
Operating mode, immersed	S1
Operating mode, non-immersed	S3 25% ²⁾
Fluid temperature	3 ... +40 °C (37 ... 104 °F)
Fluid temperature, short-term for 3 min	90 °C (194 °F)
Max. immersion depth, 4 m (13 ft) connection cable	1 m (3 ft)
Max. immersion depth, 10 m (33 ft) connection cable	3 m (10 ft) ³⁾
Protection class	IP68
Insulation class	F
Max. switching frequency	50/h

Key

* IG = female thread, AG = male thread

¹⁾ In accordance with ISO 8601

²⁾ 2.5 min operation/7.5 min standby

³⁾ Also applies to pumps with a 30 m (98 ft) connection cable.

2.3 Type key

Ex-ample: **Drain TMW 32/11HD-10M**

TM

Series

W

Version:

- Without = standard
- W = with twister function
- R = with flat suction

32

Nominal diameter of pressure connection

11

Max. delivery head in m

HD

Version for aggressive fluids (AISI 316L)

10M

Varying cable lengths:

- Without = 4 m (13 ft) connection cable
- 10M = 10 m (33 ft) connection cable
- 30M = 30 m (98 ft) connection cable

2.4 Scope of delivery

Drain TM 32

- Pump
- Hose connection, enclosed
- Installation and operating instructions

Drain TMW 32

- Pump
- Swing check valve, pre-assembled
- Installation and operating instructions

Drain TMR 32

- Pump
- Swing check valve, pre-assembled
- Installation and operating instructions

2.5 Functions

2.5.1 Self-switching thermal motor monitoring

If the motor becomes too hot, the pump is deactivated. After the motor has cooled down, the pump is automatically switched on again.

2.5.2 Float switch

The pump (except for TM 32/8-10M) is equipped with a float switch. The float switch is used to switch the pump on and off depending on the level:

- Upper floater: Pump on
- Lower floater: Pump off

3 Application/use

3.1 Intended use

For the pumping in domestic areas of:

- Sewage not containing faeces
 - Wash basins
 - Shower basins/bathtubs
 - Washing machines
- Wastewater (with small amounts of sand and gravel)
 - Rainwater
 - Drainage water
- Fluid temperature: 3 ... +40 °C (37 ... 104 °F), max. 90 °C (194 °F) for 3 minutes

Use inside and outside buildings



NOTICE

For use inside buildings only

Use pumps with a connection cable less than 10 m (33 ft) long only inside buildings. Use outside buildings is prohibited!

Pump type Wilo-Drain	Connection cable length	Outdoor application	Indoor application
TM 32/7	4 m (13 ft)	—	•
TM 32/8-10M	10 m (33 ft)	•	•
TMW 32/8	4 m (13 ft)	—	•
TMW 32/8-10M	10 m (33 ft)	•	•
TMW 32/11	4 m (13 ft)	—	•
TMW 32/11-10M	10 m (33 ft)	•	•
TMW 32/11-30M	30 m (98 ft)	•	•
TMW 32/11HD	10 m (33 ft)	•	•
TMR 32/8	4 m (13 ft)	—	•
TMR 32/8-10M	10 m (33 ft)	•	•
TMR 32/11	4 m (13 ft)	—	•

Key:

— = Not permitted, • = Permitted

3.2 Improper use



DANGER

Explosion due to pumping of explosive fluids!

Pumping of highly flammable and explosive fluids (gasoline, kerosene, etc.) in pure form is strictly prohibited. There is a risk of fatal injury due to explosion! The pumps are not designed for these fluids.

The submersible pumps must **not be used** for pumping:

- Untreated sewage
- Sewage containing faeces
- Drinking water
- Fluids containing hard components (such as stones, wood, metal, etc.)
- Fluids containing high quantities of abrasive contents (e.g. sand, gravel).
- Viscous fluids (e.g. oil and grease)
- Seawater

Intended use also includes compliance with this manual. Any other use is regarded as non-compliant with intended use.

4 Transport and storage

CAUTION

Soaked packaging may tear!

The product may fall on the ground if unprotected and may be damaged. Lift wet packaging carefully and replace it immediately!

- Wear protective equipment!
- Carry the pump by the handle. Never carry or pull on the connection cable!
- Clean the pump and disinfect if necessary.
- Close the discharge connection.
- Protect the connection cable against kinking and damage.
- Use original packaging for transport and storage.
- Pack the pump when dry. Wet or humid pumps may soften the packaging.
- Storage conditions:
 - Maximum: -15 ... +60 °C (5 ... 140 °F), max. humidity: 90 %, non-condensing
 - Recommended: 5 ... 25 °C (41 ... 77 °F), relative humidity: 40 ... 50 %

5 Installation and electrical connection

5.1 Installation types

Installation type	Wilo-Drain		
	TM ...	TMW ...	TMR ...
Stationary wet well	•	•	•
Portable wet well	•	o	o
Dry well installation	–	–	–
Horizontal installation	–	–	–

Key:

– = Not permitted, o = Possible with separate hose connection, • = Possible

5.2 Installation

- Wear protective equipment!
- Do not install a damaged or defective pump.
- Frost-free location.
- Lay the connection cable properly. During operation there must be no danger (stumbling, damage, etc.).
- Float switch must be able to move freely!

5.2.1 Stationary wet well installation

For stationary wet well installation, the pump is installed directly onto the pressure pipe. Observe and adhere to the following points:

- The connected pressure pipe must be self-supporting. The pressure pipe must not be supported by the pump.
- The pump may oscillate slightly during operation. These oscillations must be dissipated via the pressure pipe.
- Ensure that the connection to the pressure pipe is stress-free – do not screw it in too tightly.
- Seal pipe connections with Teflon tape.
- Install all specified valves in accordance with local requirements (gate valve, non-return valve).
- Install the pressure pipe so that it is protected from frost.

- Install the pressure pipe as a "pipe loop" to avoid backflow from the main public sewer.
At its highest point, the bottom edge of the pipe loop must be above the locally determined backflow level!

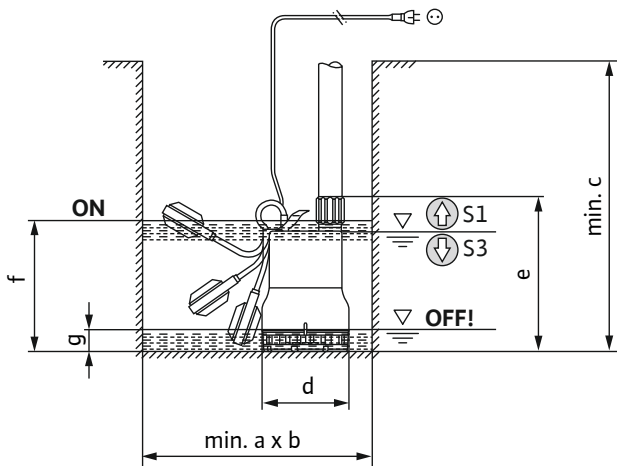

Fig. 2: Installation dimensions and switching points

ON	Switch-on level (dimension: f)
OFF	Switch-off level (dimension: g)
⬆	Fill level above: Continuous duty (operating mode immersed)
⬇	Fill level below: Intermittent periodic duty (operating mode non-immersed)

Installation dimensions

Pump type	a	b	c	d	e	f	g
Wilo-Drain							

Dimensions in mm

TM 32/7	350	350	300	165	294	237	14
TM 32/8	350	350	300	165	294	250	14
TMW 32/8	350	350	300	165	296	250	11
TMW 32/11	350	350	330	165	326	280	14
TMR 32/8	350	350	300	165	278	250	8
TMR 32/11	350	350	330	165	308	280	11

Dimensions in inches

TM 32/7	14	14	11	6.5	11.6	9.3	0.6
TM 32/8	14	14	11	6.5	11.6	10	0.6
TMW 32/8	14	14	11	6.5	11.7	10	0.4
TMW 32/11	14	14	13	6.5	12.8	11	0.6
TMR 32/8	14	14	11	6.5	11	10	0.3
TMR 32/11	14	14	13	6.5	12.1	11	0.4

- ✓ Site is prepared.
 - ✓ Pressure pipe properly installed
1. Screw the discharge pipe fully into the pump's discharge connection.
 2. Position the pump at the installation site.
CAUTION! Use a hard surface or underlay at the installation site to prevent sinking on soft substrate.
 3. Connect the discharge pipe to the pressure pipe (e.g. using a flexible hose section).
 4. Secure the connection cable to the pressure pipe and route it to the socket.

▶ Pump is installed.

5.2.2 Portable wet well installation

The pump can be installed at any location on the application site when carrying out portable wet well installation. Observe and adhere to the following points:

- Secure the pump against falling over and moving (creeping) during use.
- Secure the pressure hose to the hose connection.
- ✓ Site is prepared
- ✓ Pressure hose to be used: Min. inside diameter 1½"
- ✓ Hose clip to be used: 40 – 60 mm inside diameter (1.6 – 2.4 in)
- ✓ Hose connection to be used:
 - Drain TM ...: contained in scope of delivery
 - Drain TMW .../TMR ...: to be purchased as accessories

1. Fit the hose connection.

Drain TM ...

- Undo the union nut at the pressure port.
- Position the hose connection on the pressure port.
- Position the union nut over the hose connection and tighten over the pressure port.

Drain TMW .../TMR ...

- Fully screw the hose connection provided by the customer into the pressure port.
- ⇒ Hose connection is installed.

2. Slide the hose clip over the pressure hose.

3. Slide the pressure hose onto the hose connection at the pressure port.

4. Secure the pressure hose to the hose connection using the hose clip.

5. Position the pump at the installation site.

CAUTION! Use a hard surface or underlay at the installation site to prevent sinking on soft substrate.

6. Route the pressure hose and fasten it to an appropriate point (e.g. the drain off). **NOTICE! If the pump is being positioned in a full chamber, hold the pump at a slight angle during immersion. This will help air to escape from the pump more easily!**

7. Route the connection cable to the socket.

▶ Pump is installed.

5.3 Electrical connection

- Mains connection with correctly installed protective earth conductor.
- Residual-current device (RCD) is installed with 30 mA.
- Mains connection fuse protection: max. 10 A.
- Voltage (U) and frequency (f) data on the rating plate correspond to the data of the mains connection.

Do **not** connect the pump if:

- The connection cable is damaged
Have the connection cable replaced by a qualified electrician or the customer service.
- A standalone inverter is in use
Stand-alone inverters are used in autonomous power supplies, e.g. solar power supply, and can generate overvoltages. Overvoltages can destroy the pump.
- A multiple plug socket or power strip is in use

- An energy-saving plug is in use
This reduces the energy supply to the pump and the pump may heat up too much.
- Operation on start-up controls
The pump is not suitable for operation on a frequency converter or a soft start control.
- Explosive atmospheres
Do not connect and operate the pump inside potentially explosive atmospheres!

5.3.1 Connection: Pump with plug

Provide for a socket (type E or type F) with earthing contact. To connect the pump, insert the plug into the socket.



NOTICE

Pump starts up or is ready for operation!

Once the plug is connected to the socket, the pump will either start immediately or be ready for operation:

- Pump **without float switch**: pump switches on immediately!
- Pump **with float switch**: pump is ready for operation and will switch on depending on the fill level!
 - ▶ We recommend switching the socket on and off using a separate main switch!

5.3.2 Connection: Pump without a plug



DANGER

Risk of fatal injury due to electrical current!

Improper conduct when carrying out electrical work can lead to death due to electric shock!

- Electrical work must be carried out by a qualified electrician!
- Observe local regulations!

CAUTION

Irreparable damage as a result of water penetration

Connection cables without plugs feature bare cable ends. Water may penetrate the connection cable and pump via these bare cable ends. This will destroy both the connection cable and the pump. Never immerse the bare end of the connection cable in fluid. Firmly seal it during storage.

If the pump is to be connected to a switchgear, cut off the plug. Carry out connection to a switchgear as follows:

Wire colour	Terminal in switchgear
Brown (bn)	L (phase)
Blue (bl)	N (neutral conductor)
Green/yellow (gn-ye)	Earth (protective earth conductor)

Adjust the motor protection

Set the motor protection switch to the rated current (see rating plate).

6 Commissioning



DANGER

Risk of fatal injury due to electrical currents in accessible basins!

Do not operate the pump if there are persons in contact with the fluid. In the event of a fault this may cause death by electric shock! Only activate the pump when there are no longer any persons in contact with the fluid.



NOTICE

Check the inlet quantity!

The maximum inlet volume flow must be less than the maximum pump delivery rate. If the inlet quantity is higher, the pump will not be able to pump away the volume flow. The pump chamber may overflow!

6.1 Before activating

Check the following prior to activation:

- Has the electrical connection been carried out in accordance with regulations?
- Has the connection cable been routed safely?
- Can the float switch move freely?
- Temperature of the pumped fluid observed?
- Immersion depth observed?
- Are the pressure pipe and pump sump free of deposits?
- All gate valves in the pressure pipe open?

6.2 Switching on and off

The pump is switched on and off depending on the version:

- Pump **with plug, without float switch**
The pump will switch on immediately after the plug has been inserted into the socket. To switch off the pump, pull the plug.
- Pump **with plug and float switch**
The pump will switch on and off automatically on reaching the switching level:
 - Upper floater: Pump on.
 - Lower floater: Pump off.

6.3 Test run

If the pump is installed stationary (e.g. cesspool, overflow shaft), carry out a test run. Check the following points with the test run:

- General conditions (inflow quantity, switching points)
- Direction of rotation (with 3~ motors)

The test run must include three pump cycles.

1. Flood the pump chamber: Open inlet.
NOTICE! The required feed quantity for the test run can also be simulated using another water source.
2. When the switch-on level is reached: pump starts.
3. Switch-off level reached: pump stops.

4. Repeat two more pumping processes.
 - ▶ Once three pumping processes have been completed without problems, the test run is finished.

NOTICE! If the pump does not switch on once a week, repeat the test run every month.

6.4 Drain TMR flat suction

Tie up the float switch prior to commissioning to make the most of the flat suction (2 mm/0.1 in).

- ✓ Attach the float switch to the handle.
 - ✓ Separate on/off switch available. If the floater is tied up, the pump starts immediately after the plug is plugged in.
1. Lower the pump to its deployment position.
 2. Route the connection cable to the socket.
 3. Plug in the plug.
 4. Activate the pump via the separate on/off switch.
 5. Run the pump until the residual water level has been reached.

NOTICE! It is normal for a small amount of water to escape from between the strainer and housing when the residual water level has been reached. This is required for the operational reliability of the pump.
 6. Switch off the pump via the separate on/off switch.

6.5 During operation

CAUTION

Do not allow the pump to dry run!

Do not run the pump without fluid (dry run). Switch off the pump once the residual water level has been reached. Dry running may destroy the seal and cause the pump to be irreparably damaged.

Check the following points:

- Inlet quantity corresponds to the pump delivery rate.
- Float switch is operating correctly.
- Connection cable is not damaged.
- Pump free from deposits and encrustations.

7 Removal



DANGER

Risk of infection due to fluids hazardous to health!



Hazardous germs can form in standing waters. If there is a risk of germ formation, observe the following points:

- Ensure sufficient air exchange.
- Wear a breathing protection mask e.g. Half mask 3M series 6000 with filter 6055 A2.
- Disinfect product.



- Wear protective equipment!
- Depending on the operating mode and duration, the housing parts become hotter than 40 °C (104 °F).
 - Only touch the product by the carrying handle.

- Allow product to cool down.

- Clean the device thoroughly.

7.1 Stationary wet well installation

1. Close the gate valve in the inlet and pressure pipe.
2. Switch off pump.

Pump **with** a plug: Pull the plug.
Pump firmly connected (**without** plug): Disconnect the pump from the mains. **DANGER! Have electrical work carried out by a qualified electrician!**
3. Disconnect the connection cable from the pressure pipe.
4. Release the pump and discharge pipe from the pressure pipe.
5. Lift the pump by the handle out of the operating space.
6. Unscrew the discharge pipe from the pressure port.
7. Coil up the connection cable and store it with the pump.
8. Clean pump and discharge pipe thoroughly.
 - ▶ Pump removed.

If the pump remains installed, observe the following points:

- Protect pump from frost and ice:
 - Immerse the pump completely in the pumped fluid.
 - Min. ambient temperature: +3 °C (+37 °F)
 - Min. fluid temperature: +3 °C (+37 °F)
- If the pump will not be used for a prolonged period, switch on pump and carry out one pumping process every 2 months to prevent encrustations and clogging. Only carry out the pumping process under suitable operating conditions!

If the above points are not guaranteed, remove the pump!

7.2 Portable wet well installation

1. Switching off the pump: Disconnect the plug.
2. Lift the pump by the handle out of the operating space.
3. Loosen the hose clip and pull the pressure hose off the discharge port.
4. Coil up the connection cable and store it with the pump.
5. Clean pump and pressure hose thoroughly.

8 Cleaning

- Wear protective equipment!
The protective equipment prevents contact with germs that are hazardous to health and the disinfectant.
- If a disinfectant is used, follow the manufacturer's instructions!
 - Wear protective equipment according to the manufacturer's instructions! If in doubt, ask your specialist dealer.
 - Inform all persons about the disinfectant and how to use it correctly!
- Drain the water used for cleaning into the sewage system.

8.1 Clean pump

- ✓ Pump removed.
 - ✓ Disinfectant is available.
1. Ensure that the plug or bare cable end is packed and stored in a watertight manner!
 2. Rinse the pump and cable under clean, running water.
 3. Allow water to flow through the discharge port to clean the jacket cooling channel.

4. Rinse attachments such as the discharge pipe and pressure hose with clean, running water.
5. Flush dirt residue on the floor into the sewage drain.
6. Allow the pump to dry out.
7. Only clean the plug or bare cable end with a damp cloth!
 - ▶ Pump has been cleaned. Pack and store the pump.

NOTICE! If the strainer and turbulator (twister function) are very contaminated, remove the strainer and turbulator for thorough cleaning!

8.2 Removing and cleaning the strainer

Remove and clean the strainer if there is severe dirt and encrustation. **NOTICE! For the Drain TMW ... pump, the turbulator (twister function) must be removed first!**



WARNING

Sharp edges on the impeller and strainer!

Sharp edges can form on the impeller and strainer. There is a danger of cuts and similar injuries!

- Wear protective gloves!

1. Place the pump on a firm surface in a horizontal position.
2. Secure the pump against slipping!
3. Unscrew the 4 fastening screws (\varnothing 4 x 60 mm) at the bottom of the strainer.
4. Remove the strainer from the pump housing.
5. Rinse the strainer and impeller under clean, running water. Remove solids by hand.
6. Check the O-ring on the pump housing. If the O-ring has been damaged (cracks, porosity, crushed areas), replace the O-ring: \varnothing 155 x 2 mm.
7. Place the strainer on a firm surface.
8. Lower the pump onto the strainer to position. **CAUTION! Damage to property! When the strainer is pressed against the pump housing, do not damage the O-ring!**
9. Turn the pump and fully screw in the 4 fastening screws (\varnothing 4x60 mm). **NOTICE! Replace worn screws!**
 - ▶ Strainer cleaned and fitted. Complete the cleaning work.

8.3 Removing and cleaning the turbulator

Remove and clean the turbulator in the event of severe dirt and encrustations.

1. Place the pump on a firm surface in a horizontal position.
2. Secure the pump against slipping!
3. Unscrew the 4 fastening screws (\varnothing 3.5 x 14 mm) at the bottom of the turbulator.
4. Remove the turbulator from the strainer.
5. Rinse the turbulator under clean, running water. Remove solids by hand.
6. If necessary, remove, clean and reinstall the strainer.
7. Position the turbulator on the strainer.
8. Turn the pump and fully screw in the 4 fastening screws (\varnothing 3,5x14 mm). **NOTICE! Replace worn screws!**

- ▶ Turbulator cleaned and fitted. Complete the cleaning work.

9 Maintenance

9.1 General overhaul

Have the customer service team check the pump after 1,500 operating hours. All components will be checked for wear and damaged components will be replaced.

10 Faults, causes and remedies

Pump not starting or switches off after a short time

1. Interrupted power supply
 - ⇒ Check the electrical connection of the pump.
 - ⇒ Have a qualified electrician check fuses/residual-current devices.
2. Thermal motor monitoring has been tripped
 - ⇒ Allow the pump to cool down. The pump will start automatically.
 - ⇒ Pump switches on/off too frequently. Check the switching cycle of the float switch.
 - ⇒ Excessive fluid temperature. Check the temperature. If necessary, use a different pump.
3. Suction port/strainer/impeller silted/clogged
 - ⇒ Shut down the pump, remove it and clean it.
4. Float switch not operational
 - ⇒ The float switch must be able to move freely.

Pump starts up, but does not supply fluid

1. Pressure pipe/discharge pipe clogged
 - ⇒ Flush out the pressure pipe.
 - ⇒ Flush out the pressure hose.
 - ⇒ Remove any kinks in the pressure hose.
2. Swing check valve contaminated
 - ⇒ Shut down the pump, remove it and clean the discharge connection.
 - ⇒ Replace faulty swing check valve.
3. Water level too low
 - ⇒ Check inlet.
 - ⇒ Pump is pumping at a too low level. Check the switching cycle of the float switch.
4. Suction port/strainer silted/clogged
 - ⇒ Shut down the pump, remove it and clean it.
5. Air in the pump/pressure pipe
 - ⇒ Position the pump at a slight angle to allow air to escape.
 - ⇒ Install a bleed unit in the pressure pipe.

Delivery rate drops while the pump is running

1. Pressure pipe/discharge pipe clogged
 - ⇒ Flush out the pressure pipe.
 - ⇒ Flush out the pressure hose.
 - ⇒ Remove any kinks in the pressure hose.
2. Suction port/strainer silted/clogged
 - ⇒ Shut down the pump, remove it and clean it.

3. Air in the pump/pressure pipe
 - ⇒ Position the pump at a slight angle to allow air to escape.
 - ⇒ Install a bleed unit in the pressure pipe.
4. Signs of wear
 - ⇒ Contact customer service.

Customer service

If the points listed here do not rectify the fault, contact customer service. Costs may be incurred when using customer service support! Please contact customer services for more information.

11 Spare parts

Spare parts are ordered via customer service. To avoid return queries and incorrect orders, the serial or article number must always be supplied. **Subject to change without prior notice!**

12 Disposal

12.1 Information on the collection of used electrical and electronic products

Proper disposal and appropriate recycling of this product prevents damage to the environment and danger to your personal health.



NOTICE

Disposal in domestic waste is prohibited!

In the European Union this symbol may be included on the product, the packaging or the accompanying documentation. It means that the electrical and electronic products in question must not be disposed of along with domestic waste.

To ensure proper handling, recycling and disposal of the used products in question, please note the following points:

- Hand over these products at designated, certified collection points only.
- Observe the locally applicable regulations!

Please consult your local municipality, the nearest waste disposal site, or the dealer who sold the product to you for information on proper disposal. See www.wilo-recycling.com for more information about recycling.





wilo



Local contact at
www.wilo.com/contact

Pioneering for You

WILO SE
Wilopark 1
44263 Dortmund
Germany
T +49 (0)231 4102-0
T +49 (0)231 4102-7363
wilo@wilo.com
www.wilo.com