

Gas Installations engineering services

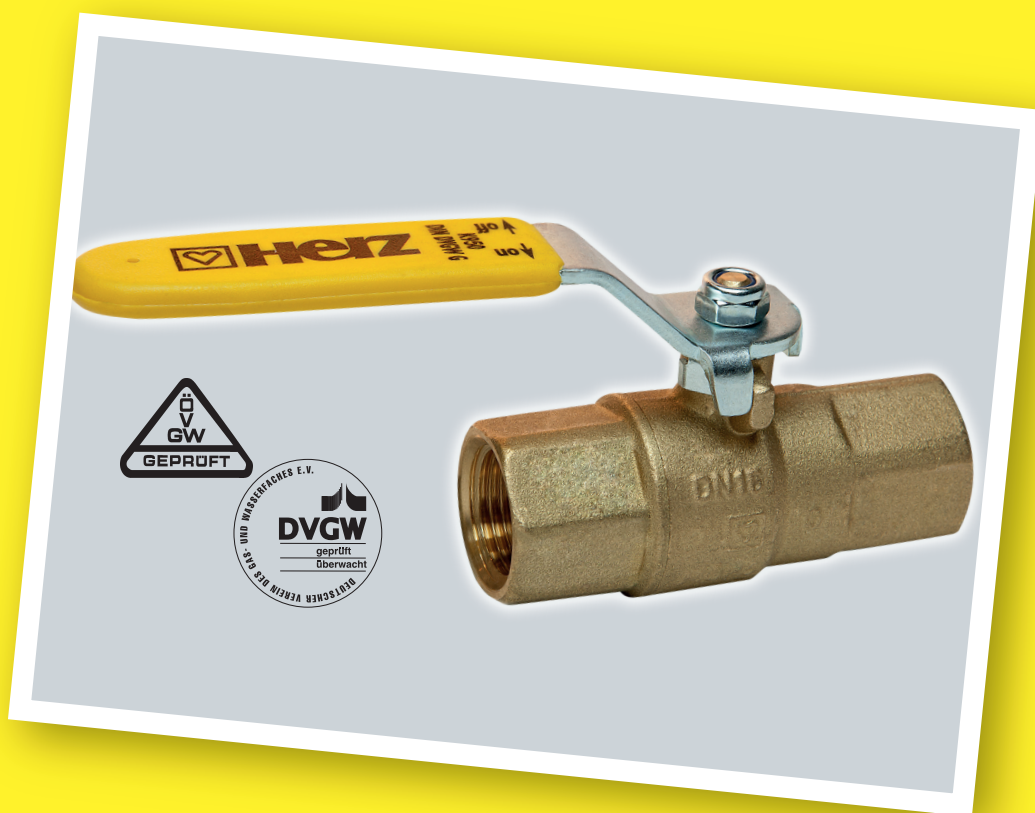

Contents:	Page
General information	2
Implementation of a building connection	5
Plastic pipes and press fittings	8
Dimensioning of gas lines	10
Press fittings for gas lines	14
Laying information	14
Processing HERZ PipeFix	18
Pipeline network calculation	19
Pressure test	22
Product range	23
Technical information on HERZ products	31
Certificates	39

Gas has been used as fuel for heat and light sources since the beginning of the 19th century.

Coking plant coal gas (town gas), a by-product of coke production, was used in households and today serves as valuable energy carrier in steel mills.

Since the middle of the 20th century natural gas has been used in households.

Natural gas is a fossil energy carrier mainly being used for the heating of residential properties and commercial premises as well as for industrial power generation. To a small extent natural gas is also used as fuel for motor vehicles. In addition, natural gas is a reacting agent in many chemical processes such as during hydrogen generation or the production of nitrogen-based fertilizers.

In view of the limited natural gas resources, biogas production will become more and more important in future. Biogas (digester gas) is a blend of methane and carbon dioxide and is produced in biogas plants by digestion of organic matter. Sludge, biowaste, liquid manure, manure and also selectively cultivated bioenergy plants are suited for biogas production. In many countries, the processing to a natural gas quality level is still unprofitable due to low energy costs, that's why biogas is only admixed to natural gas.

Since natural gas today is the most commonly utilized gas, this article will mainly provide information on its use.

Composition of natural gas:

Natural gas is mainly composed of methane, the remaining components being largely dependent on the lieu of deposit. Large proportions of higher hydrocarbons such as ethane, propane and butane are desired and are extracted from natural gas. Additional minor components are hydrogen sulfide and up to 9 % of carbon dioxide. During combustion of hydrogen sulfide, harmful sulfur dioxide is produced; that's why natural gas is desulfurized through gas scrubbing. Carbon dioxide, which is worthless in terms of energy generation, is released to the atmosphere. Natural gas with a helium proportion of up to 7 % of helium is exceptionally valuable since it is used to extract helium.

- Natural gas "L" (Low) 85 % methane, 4 % additional alkanes (ethane, propane, butane, pentane), 11 % inert gases (neon, argon, xenon, etc.)
- Natural gas "H" (High) North Sea 89 % methane, 8 % additional alkanes, rest: inert gases
- Natural gas "H" (High) Commonwealth of Independent States 98 % methane, 1 % additional alkanes, rest: inert gases

Gases are also classified by their heating value. The unit is called "Wobbe index". It indicates the heating value at the burner at identical gas pressure and without any system alterations or exchange of nozzles.

- 1. Wobbe index 19 - 31.4 MJ/m³ = 5.28 - 8.73 kWh/m³**
 - Town gas
 - Coke oven gas
 - Hydrocarbon/air mixtures (biogas)
- 2. Wobbe index 42.3 - 58 MJ/m³ = 11.76 - 16.12 kWh/m³**
 - Natural gas
- 3. Wobbe index 77.4 - 92.4 MJ/m³ = 21.52 - 25.69 kWh/m³**
 - Liquid gases propane and butane

Natural gas is a combustible, colorless and normally odorless and nonpoisonous gas. In order to be able to localize escaping natural gas, aromatic substances are added (odorization), simulating typical gas odor.

Natural gas is lighter than air, its density is $\rho = 0.7 - 0.84 \text{ kg/m}^3$.

Required volume of combustion air for 1 m³ of combustion gas

- for 1 m³ town gas = 5 - 6 m³ air
- for 1 m³ natural gas L = 10.5 - 12 m³ air
- for 1 m³ natural gas H = 12.5 - 15 m³ air
- for 1 m³ propane = 30.5 m³ air
- for 1 m³ butane = 39.5 m³ air

The combustion of natural gas is expressed by the following chemical formula:

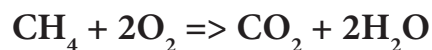

Of all carriers of energy, natural gas (CH₄) shows the highest contents of hydrogen (H) and the lowest contents of carbon (C). As a consequence, during combustion of natural gas – the energy contents being the same – considerably less carbon oxides (CO, CO₂) are produced as compared to coal or mineral oil products.

Owing to its low amount of impurities natural gas shows the cleanest combustion behavior compared to other fossil fuels.

Natural gas is exploited by drilling into natural gas fields or it is recovered as a byproduct from petroleum production. Delivery takes place at approx. 70 bars from the borehole via valves to collecting points.

- Long-distance supply usually is ensured via pipelines and compressor stations within a pressure range of > 1 – 100 bars (high pressure installations).
- The distribution pipe lines and connection pipe lines are usually run within a medium pressure range of > 100 mbars – 1 bar.
- Gas consumers such as cooking plates, boilers and other devices operate in the low-pressure range < 100 mbars.

Pressure reduction between distribution and supply lines occurs in gas pressure regulating stations upstream of the building connection. Recording of gas consumption for billing purposes can be done centrally at the regulating station or remote upstream of the consumer.



Gas pressure regulating station



gas meter

Technical and scientific basic rules guaranteeing the security and reliability of gas and water supply systems are created by independent and non-profit organizations in the individual countries. Experts from interested circles write technical basic rules in a voluntary cooperation that are also referenced as part of the relevant legislation. Another task is the certification of certain system components.

The organization is headed by IGU (International Gas Union), founded in 1931. Its members come from unions and organizations of the gas industry across 67 countries.

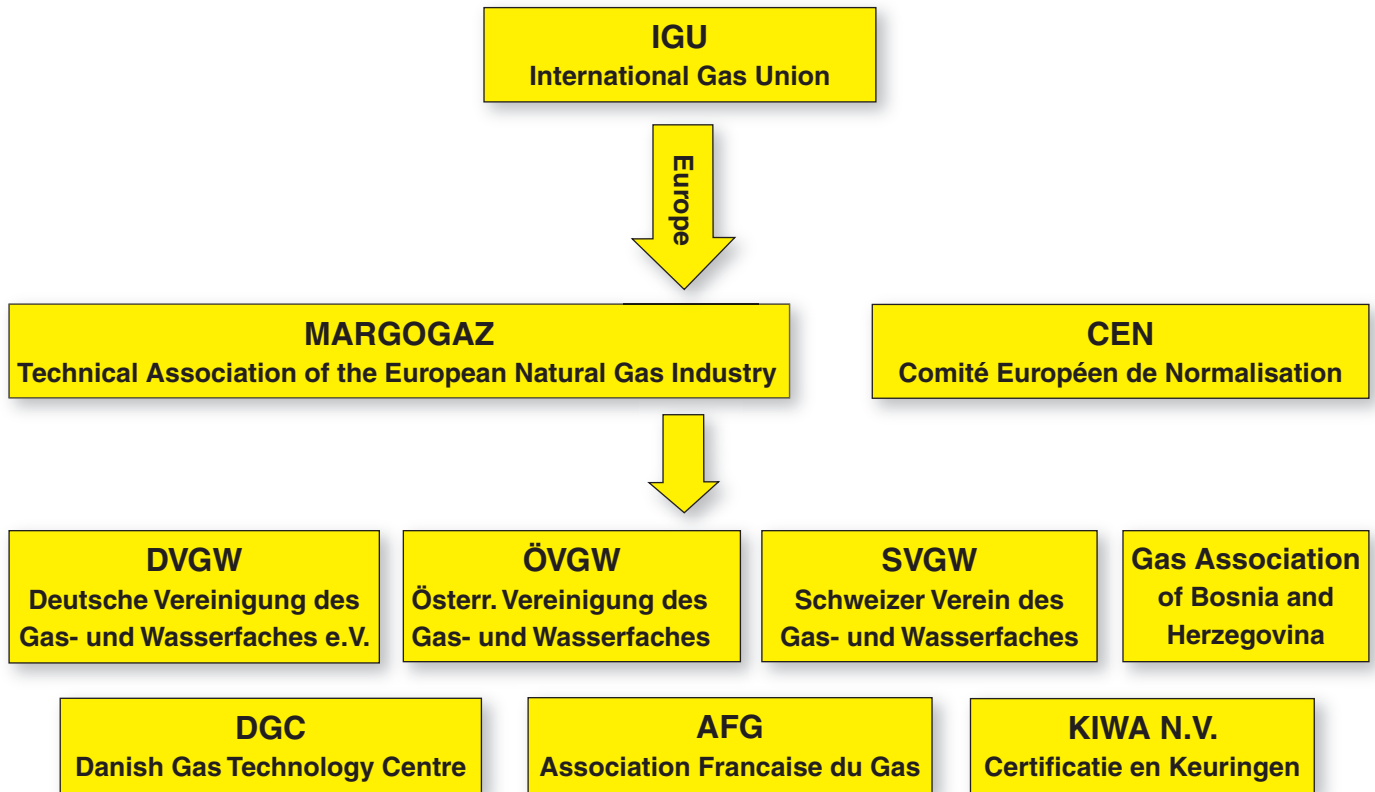

In cooperation with its members and market partners they are striving to ensure the safe and permanent provision of natural gas.

In countries where there is no union, the guidelines of neighboring countries or other reputable associations are taken into account.

In addition, the safety regulations of the respective gas supply companies must be adhered to. These regulations usually take account of local conditions and the position of valves in consuming systems.



Atmospheric 4-stage gas boiler

General design of a building connection

The building connection pipe is connected to an existing isolating valve (gate valve or valve) on the main supply pipe. If no isolating valve is present, the main supply pipe is connected via a tapping slide valve.

These isolating valves are usually situated belowground with an access cap at ground level.

A gas flow monitor must be installed as close as possible to the building connection pipe. The gas flow monitor is an automatically closing valve that can also be integrated into an electro-welded sleeve of the pipeline. The positioning close to the connection point serves to avoid major gas leakages if damaged during excavation work.

In order to accommodate for different shapes of premises and houses, different building lead-ins are required. The building lead-in can be fitted with or without a protective pipe. If the building lead-in is designed as a recovery, a force-fit connection to the wall must be ensured.

A building connection pipe made of PE may be fed into the building if the material junction is situated within a metal casing. The protective pipe must protrude from the outer and inner walls and must be tight.

The kind of building lead-in used depends on the construction type and the gas supply company's regulations.

The main shutoff device must always be installed at the end of the building connection pipe. 2 variants are admissible.

- Behind the building lead-in, at an easily accessible location; a higher thermal load is to be taken account of during planning.
- Before the building lead-in, at an easily accessible location in the ground, in a duct, cabinet or junction box. Here, too, a higher thermal load must be allowed for.

A gas pressure regulator needs to be installed if the supply is realized via a medium or high pressure supply network.

Secondary networks in the high pressure range 1.0 – 4.0 bars

Secondary networks in the medium pressure range 0.1 – 1.0 bars

Blanking plates are protection devices for building connections and are fitted downstream of the slip on flange, i.e. downstream of the gas pressure regulator and the connection flange with plug. They are used during construction or repair work.

Determining the pipeline route

It is essential to account for the future use of the pipeline area and the local conditions. Superstructures above buried gas pipelines are not admissible. Normally the gas supply company decides on the routing. Preferences are considered where possible.

Pipe trench, overlapping and backfilling

Excavation pits and pipe trenches have to be executed as per the relevant laying system and pipe dimensions. The trench bottom must be flat and the pipeline must lay evenly. The pipe overlap must be adapted to local conditions, however, it should not exceed or go below 0.8 m. The gas line must be covered sufficiently on all sides with fine soil. In case of sags that can occur due to loads, a packing beneath is necessary to avoid subsidences. The building connection pipe must be marked with a yellow warning tape with a label indicating that this is a gas pipe. The warning tape should be 80 mm wide and positioned 30 – 40 cm below the surface, above the gas line.

Standard dimensions for pipe trenches:

1. Trench width approx. 0.6 m
2. Trench depth approx. 1.0 m
3. Ground free of stones 0.3 m
4. Sand bed 0.1 m

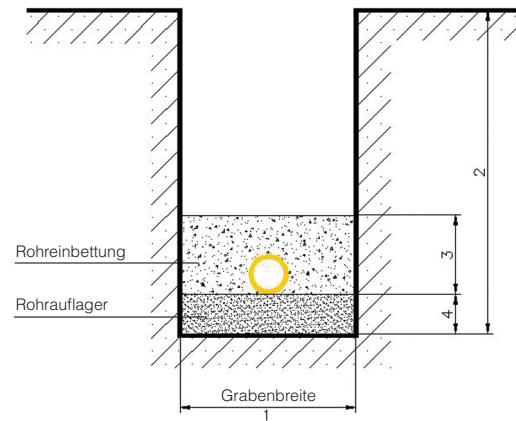

Building connection with steel pipelines

Prior to laying, the pipelines must be checked for visual damage from storage or transportation. Damage to the external protection must be avoided under all circumstances. If required, appropriate lifting devices must be used to lift and lower the pipes.

Corrosion protection represents an essential factor concerning the operating life and safety of the pipeline. Every buried pipeline must have a corrosion protection matching the expected mechanical loads. Usually this is achieved with isolating tape and primers.

The pipe connections are made by welding the pipes. This welding work must only be carried out by trained and certified experts. The weld connections are usually verified at random and in a nondestructive way.

With every building connection pipe a gas flow monitor must be installed close to the supply line. The gas flow monitor is a compulsory component and acts as an active anti-tamper protection. Gas flow monitors are used in the pressure range 35 mbars to 5 bars in medium and high pressure networks.

Building connection with plastic (PE) pipeline

Prior to laying, the pipelines must be checked for visual damage from storage or transportation.

The pipe connections are made by welding the pipes. This welding work must only be carried out by trained and certified experts.

No welding work may be carried out at temperatures below 0 °C.

Building lead-ins / insulating nipple

The building lead-ins are classified by the building construction. Basically the type of building lead-in depends on whether the building has a basement or not, and whether the building lead-in is from below or, in the case of buildings without basement, from the side.

With continuous metal connection pipes, an insulating nipple needs to be installed to disrupt electrical conductivity. In the case of low-resistance soils, high-pressure PE building gas connections with steel building lead-ins must be equipped with insulating nipples in addition to passive corrosion protection. Main shutoffs with integrated insulating nipples are marked with a red ring.

Downstream of the insulating nipple, the mentioned installations must be connected to the potential equalization panel of the building. The gas line itself must not be used as earth or lightning arrester. With building connections made of PE with metal lead-in or with flexible building lead-ins it is equally necessary to install a main shutoff with integrated insulating nipple.

With building lead-ins > DN 80 an insulating nipple must be installed directly downstream of the wall bushing.
 For building connections < DN 100, grouting mortar or epoxy resin mortar must be used to seal between the wall and the pipe jacket

With building lead-ins > DN 100, a Link-Seal® seal must be used.

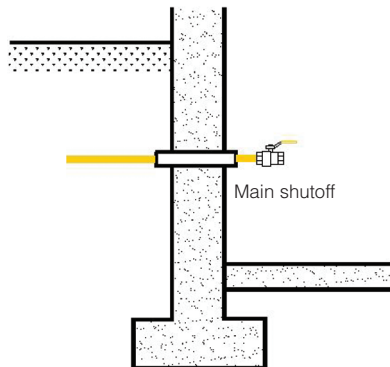

Building with basement; steel building lead-in, plastic pipeline

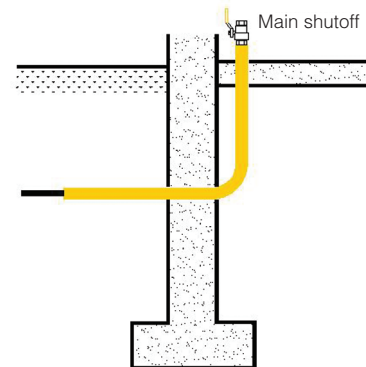

Building without basement; steel building lead-in, plastic pipeline

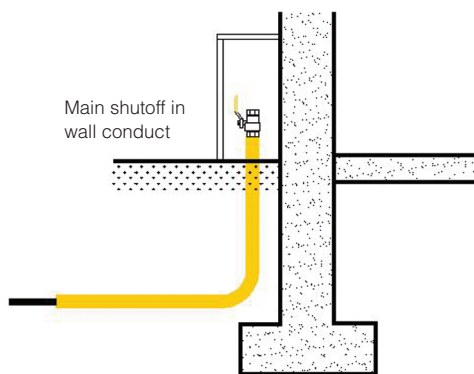

Building without basement; main shutoff outside the building in a wall conduct



Information on location of gate valve

After completion the main components and the pipeline route are measured and marked with information labels accordingly.

Completion of the building connection is followed by a pressure test of the pipeline. Generally this is done using air or an inert gas. The test pressure must be at least 2 bars higher than the admissible operating pressure.

It is recommended to periodically perform a pressure test. These tests are prescribed by many gas supply companies.

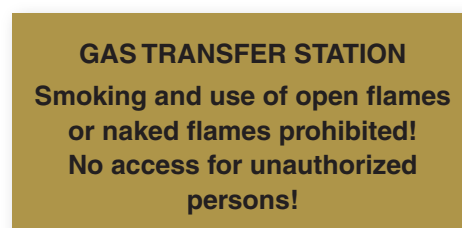
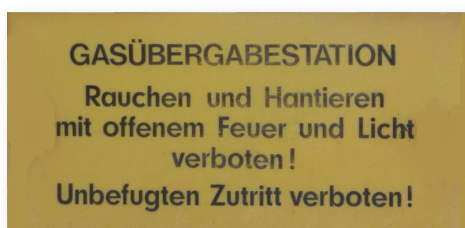

Gas meters

Due to varying connection sizes and uses of buildings, gas meters are positioned at different locations. For one and two family houses, the gas meter is positioned at the property line in a meter box. This meter box can be made of concrete or plastic or be a metal cabinet. Here, the building connection pipe is buried downstream of the meter. With industrial buildings the meter can also be installed in the interior. Easy access must be ensured.

Meter boxes at property lines are often combined with electricity building connections.

If required, a pressure reducing device must be installed in the meter box upstream of the meter. With industrial buildings where the meters are located in the interior, the pressure-reducing station is located in a separate building at the property line (pressure-reducing station). These pressure-reducing stations must be erected in accordance with the gas supply company's safety regulations and the applicable building code.

Main shutoff

A main shutoff must be installed right after the building lead-in. Main shutoffs in the wall conduct, in front of or next to buildings, require sufficient mounting space. The erection of superstructures is inadmissible. If located adjacent to traffic areas, an impact protection may be required.

In rooms exposed to fire or explosion hazards as well as in storage rooms for combustible materials, main shutoffs must not be installed. In addition, it is not admissible to exclusively have access to the main shutoff device via such rooms. Main shutoffs must not be installed in garages.

With all main shutoffs up to a nominal size of DN 50 and with all gas consumers exposed to explosion hazards by external fires, a thermal valve protection must be installed. These thermally activated valve protections (TAS) and thermally activated devices (TAE) are installed upstream of the gas-consuming units.

A temperature sensor triggers the tight sealing of the valve body and the gas line when detecting a temperature of approx. 100 °C. The TAS must be able to seal off at a thermal load of 925 °C for at least 60 minutes. In this way it effectively impedes gas explosions. With installations with gas sockets, each device connection must be equipped with a TAE, which is usually integrated into the gas socket.

Plastic pipes and press fittings

For surface-mounted pipes within buildings, composite plastic aluminum pipes are more and more frequently used, the joints being accomplished with brass press fittings. The pipes delivered as rods or on reels are already marked in the standardized yellow. For press fittings all necessary brass fittings with natural gas-resistant sealing rings are available.

During processing, guidelines and safety regulations must be strictly adhered to.

For information on processing HERZ PipeFix see also the brochures "HERZ Pipe" and "HERZ Product Range".

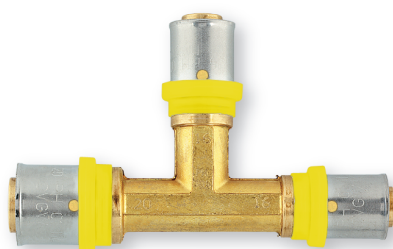

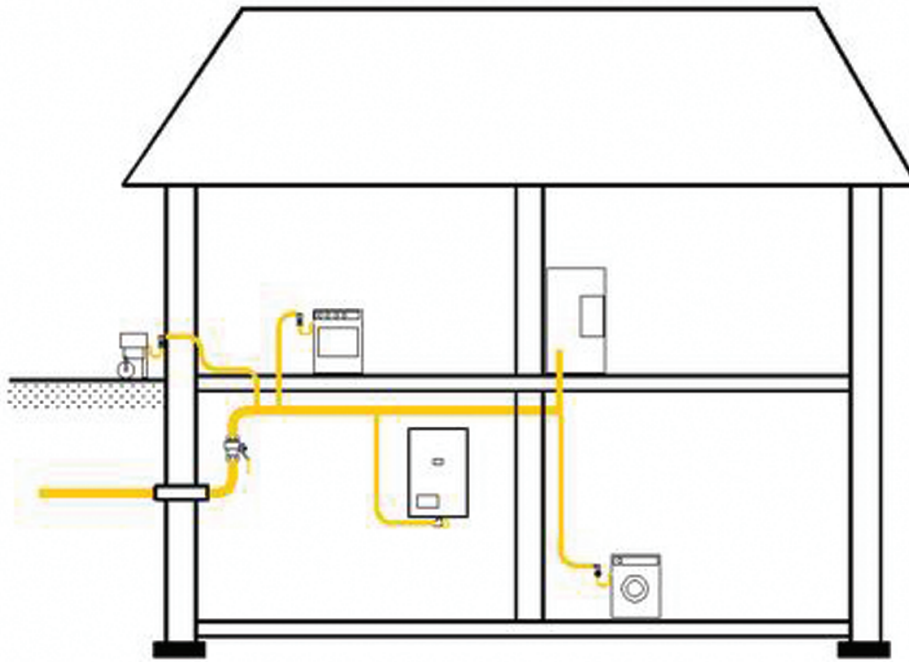

Building installations with gas sockets and composite plastic aluminum pipes allow for variable systems and the connection of various gas-consuming devices.

Choice of HERZ composite plastic aluminum pipes, at gas temperature of 12 °C and an atmospheric pressure of 1013 mbars

Applied power	Applied volume	Pipe D 16 x 2.0 mm		Pipe D 20 x 2.0 mm		Pipe D 26 x 3.0 mm		Pipe D 32 x 3.0 mm	
		Velocity	ΔP	Velocity	ΔP	Velocity	ΔP	Velocity	ΔP
kW	m³/h	m/s	Pa/m	m/s	Pa/m	m/s	Pa/m	m/s	Pa/m
1	0.11	0.25	0.70	0.14	0.20				
2	0.21	0.50	1.30	0.28	0.40				
3	0.31	0.75	2.00	0.42	0.60				
4	0.41	1.01	2.60	0.57	0.80				
5	0.51	1.26	3.30	0.71	1.00	0.45	0.40		
6	0.61	1.51	4.00	0.85	1.30	0.54	0.50		
7	0.72	1.76	4.60	0.99	1.50	0.63	0.60		
8	0.82	2.01	5.30	1.13	1.70	0.72	0.70		
9	0.92	2.26	5.90	1.27	1.90	0.81	0.80		
10	1.02	2.52	10.90	1.41	2.10	0.91	0.90	0.54	0.30
15	1.54	3.77	21.70	2.12	5.60	1.36	1.30	0.80	0.40
20	2.05	5.03	35.60	2.83	9.10	1.81	3.20	1.07	0.60
25	2.56	6.29	52.30	3.54	13.40	2.26	4.70	1.34	1.30
30	3.07	7.55	71.80	4.24	18.30	2.72	6.40	1.61	1.70
35	3.48			4.95	23.90	3.17	8.30	1.88	2.20
40	4.09			5.66	30.10	3.62	10.40	2.14	2.80
45	4.61			6.37	36.90	4.07	12.80	2.41	3.40
50	5.12			7.07	44.40	4.53	15.30	2.68	4.10
60	6.14					5.43	21.06	3.21	5.67
70	7.17					6.34	27.56	3.75	7.42
80	8.19					7.24	34.83	4.29	9.38
90	9.21							4.82	11.54
100	10.24							5.36	13.89

Dimensioning of gas lines:

Provided country-specific regulations are not to be adhered to, pipelines for combustible gases and combustible gas mixtures must be planned and installed as per DVGW-W260 and DVGW-G600-TRGI 2008 as well as taking into account the European Gas Appliances Directive and the functional standard DIN EN 1775. In addition, the Technical Standards for Gas Installations (TRGI) of the local supply companies must be adhered to.

For liquid gas installations up to 50 mbars, the basic rules TRF 1996 (Technical Standards for Liquid Gas Installations) must be adhered to.

With suction pipes conducting liquids, slightly lower velocities are opted for in order to avoid cavitation; with special pressure lines, slightly higher velocities are selected to avoid cavitation.

Please find information on tried and tested, economic velocities for gases and liquids subject to pipe interior diameters in the diagram below.

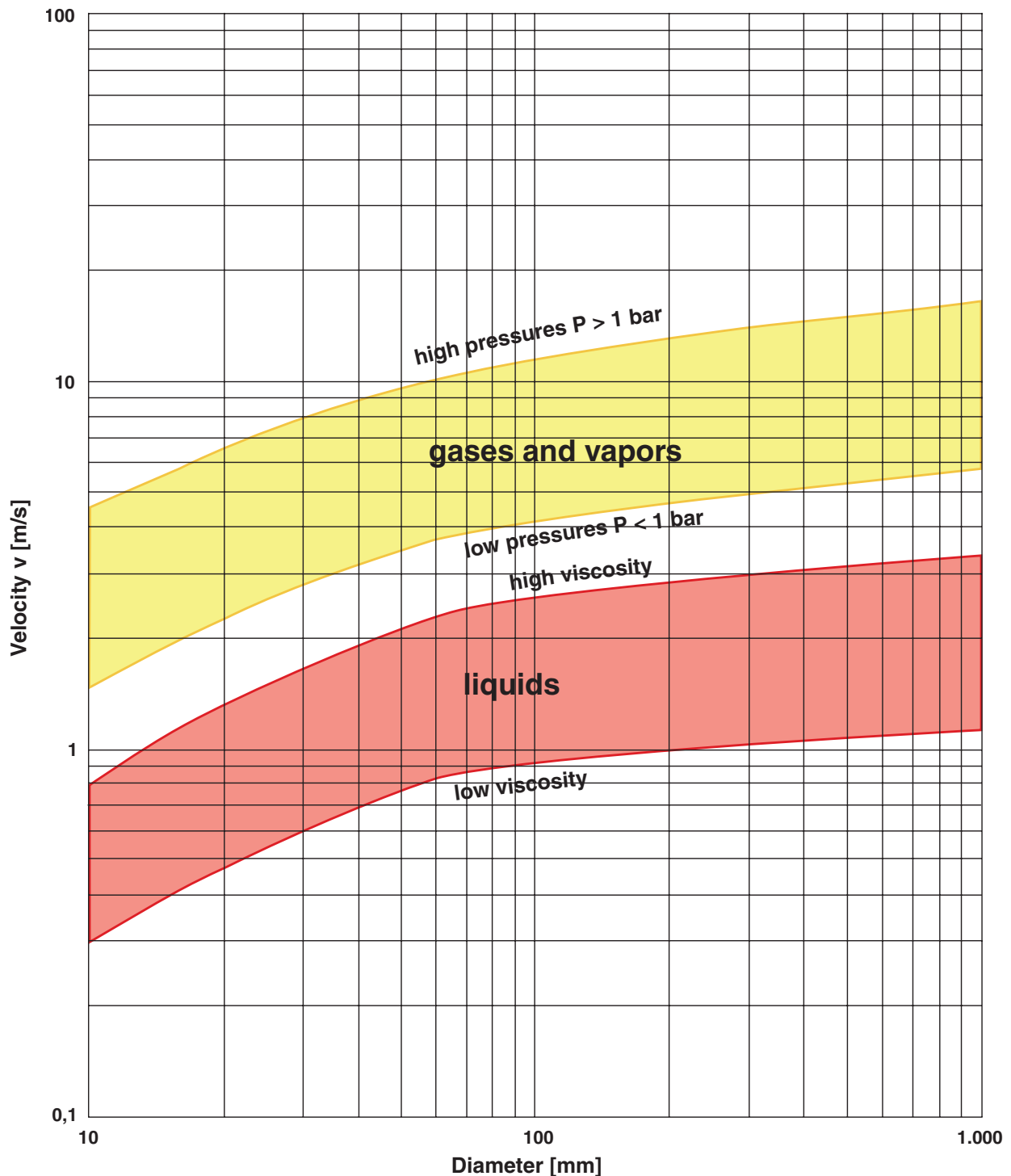

The flow velocities in gas pipelines for supply and consuming systems are usually set to 3 m/s.

For an estimate dimensioning of steel pipelines the formula below can be used.



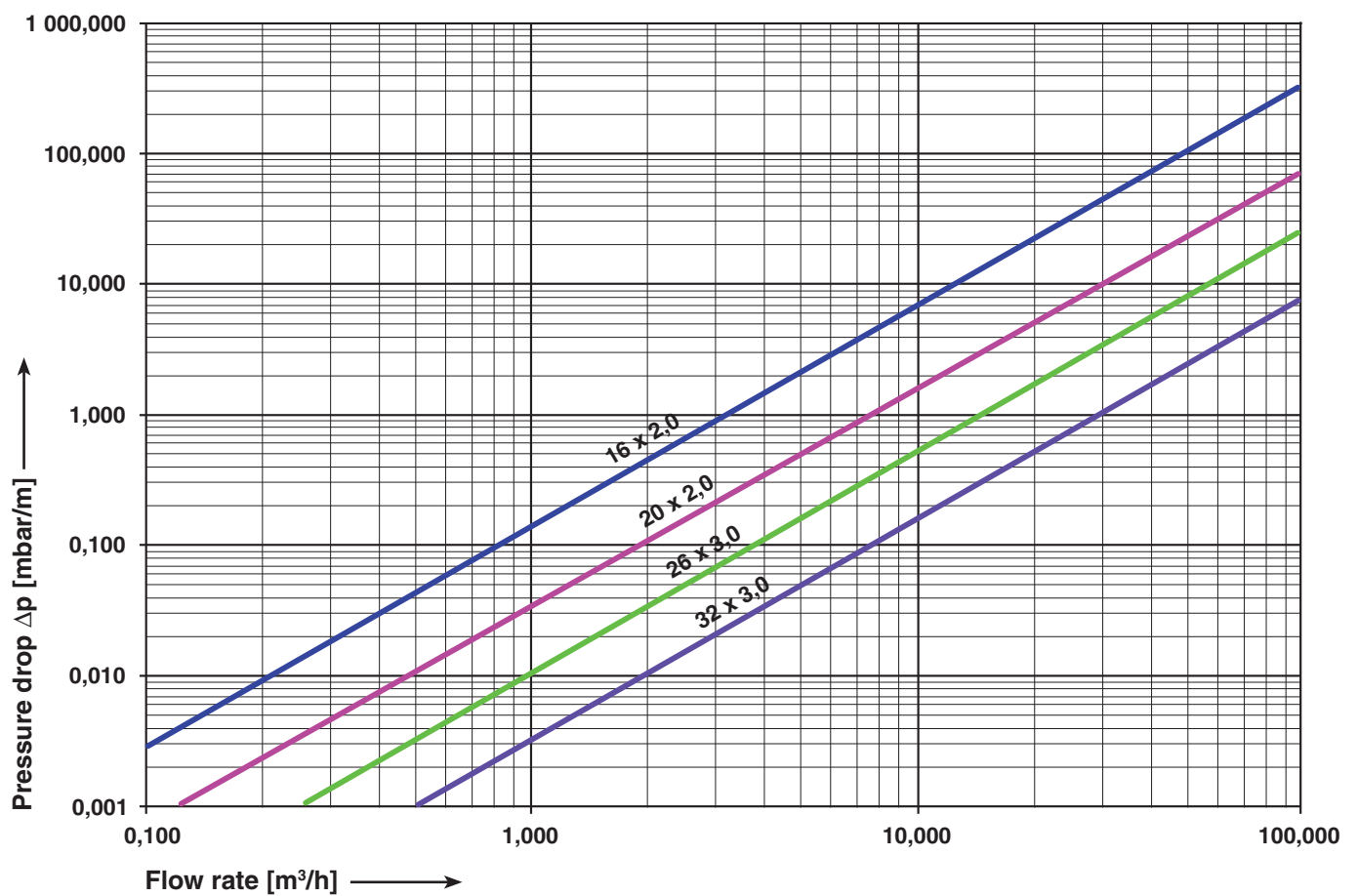

$$\text{Flow velocity } v \text{ [m/s]} = \text{Nm}^3 \frac{354}{d^2}$$

Remote supply via pipelines is most often accomplished via buried steel pipelines. Distribution systems are buried with steel pipes, increasingly also with plastic pipes. Steel pipes, buried or flush-mount, must be provided with a cathodic protection. Consuming systems are installed with threaded steel pipes, while an increased use of composite plastic aluminum pipes and press fittings can be observed.

Pressure loss in composite plastic aluminum pipe for natural gas at 20 °C

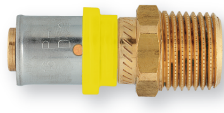
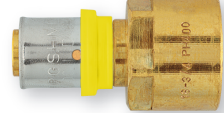

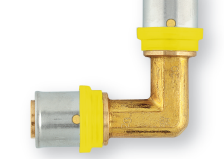
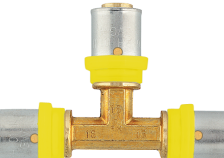
ZETA values for HERZ press fittings

Pipe dimension	Designation		Diameter internal [mm]	Zeta (gas) ζ
16	Transition with male thread 1/2 x 16 mm		12	7.00
20	Transition with male thread 1/2 x 20 mm		16	1.60
26	Transition with male thread 3/4 x 26 mm		20	1.10
16	Transition with female thread 1/2 x 16 mm		12	8.20
20	Transition with female thread 1/2 x 20 mm		16	2.80
26	Transition with female thread 3/4 x 26 mm		20	2.50
32	Transition with female thread 1 x 32 mm		26	1.70
16	Coupling 16 mm		12	6.20
20	Coupling 20 mm		16	1.80
26	Coupling 26 mm		20	1.30
32	Coupling 32 mm		26	1.30
16	Elbow 16 mm		12	15.20
20	Elbow 20 mm		16	6.60
26	Elbow 26 mm		20	6.10
32	Elbow 32 mm		26	5.10
16	T-piece connection passage 16 mm		12	8.20
20	T-piece connection passage 20 mm		16	2.80
26	T-piece connection passage 26 mm		20	2.30
32	T-piece connection passage 32 mm		26	1.30
16	T-piece connection branch 16 mm		12	18.70
20	T-piece connection branch 20 mm		16	8.30
26	T-piece connection branch 26 mm		20	7.60
32	T-piece connection branch 32 mm		26	5.80
16	Wall angle 1/2 x 16 mm		12	13.80
20	Wall angle 1/2 x 20 mm		16	9.70
26	Wall angle 3/4 x 26 mm		20	8.30

As with water, gas pipelines also show pressure losses due to friction at the pipe inner wall. The pressure loss as per the above diagram can be taken into account to perform a correct pipe network calculation. The pressure loss in the pipeline must not be larger than the minimum pressure required for the consumer.

The total pressure loss for the building installation from the meter to the consumer can be up to 250 Pa (2.5 mbars).

The coincidence factors with several installed gas devices (consumers) as well as the dynamic consideration of pressure losses occurring in components such as gas meters or flow monitors must be considered in the calculation. In accordance with DVGW worksheet G 617 a table process and a diagram process have been introduced for the pressure range up to 100 mbars.

The HERZ composite plastic aluminum pipe PE-RT has been designed for various applications and complex installation scenarios. It can be processed efficiently and shows high quality, safety and longevity. In addition, it is fully recyclable.

This multilayer pipe therefore is not only suited for heating or sanitary pipework but also for gas applications.

The outer layer of the pipes is pigmented in the standard gas identification color yellow.

Pipe designation: PE-RT / Al / PE-HD
 Meaning: PE ... Polyethylene
 RT ... Raised Temperature
 Al ... Aluminum
 HD ... High Density

Delivery as pipe bundle or pipe rods with differing aluminum thickness depending on pipe dimension (see table below).

Maximum operating temperature	95 °C
Maximum operating pressure	10 bars
Incidence temperature, incidence pressure (short-term)	110 °C, 15 bars
Internal surface roughness	0.007 mm
Heat conductivity	0.5 W/m x °K
Linear coefficient of expansion	0.024 mm/m °K
Color	yellow
Oxygen diffusion	< 0.005 mg/l d
Min. bending radius without tool	5 d
Min. bending radius with tool	3 d



HERZ Order number	Diameter (mm)	Wall thickness (mm)	Aluminum thickness (mm)	Reels (m)	Rods (m)	Weight (kg/100m)
Pipe bundle						
G 1160 20	16	2	0.4	200	-	12.90
G 1200 20	20	2	0.4	50	-	17.50
G 1260 30	26	3	0.5	50	-	29.60
G 1320 30	32	3	0.5	50	-	36.60
Pipe rods						
G 1160 21	16	2	0.4	-	5	12.90
G 1200 21	20	2	0.4	-	5	17.50
G 1260 31	26	3	0.5	-	5	29.60
G 1320 31	32	3	0.5	-	5	36.60

HERZ fittings for gas

HERZ press fittings can be connected quickly and safely to HERZ composite pipes. Disposing of decades of experience with pipe connections, HERZ produces radial press fittings made of decincifying-resistant brass with stainless steel bushings, of recognized quality and based on patented designs developed in-house. The bushings are available in virtually all shapes and sizes and approved for the connection of composite plastic pipes for gas supply in buildings. Our experience is your safety, with a 10-year guarantee for HERZ PipeFix systems.

The double O-rings are made of hydrocarbon-resistant material and suited for gas.

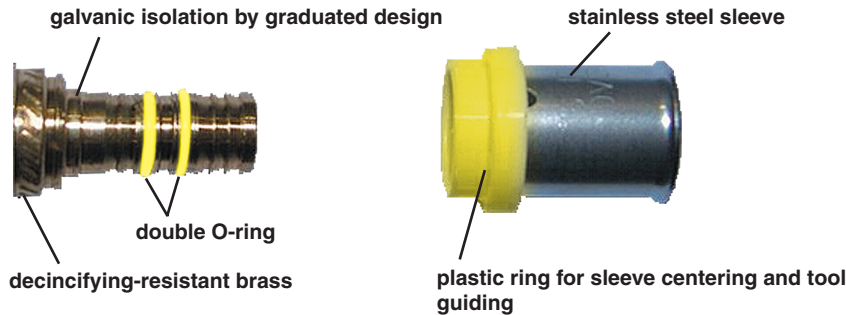

When dimensioning pipelines and calculating pipe networks, the resistance of press fittings must be taken into account of without fail.

For information on the installation of plastic pipes and press fittings please see also the brochures "HERZ Pipe" and "HERZ Product Range"



Change in length due to thermal influences

The linear expansion coefficient is 0.024 mm/m °K, independent of the pipe dimension.

The change in length of the pipes at the time of installation as compared to when the operating temperature has been reached can be calculated using the formula below.

$$\Delta l = a \cdot l \cdot \Delta t$$

- Δl = change in length
- a = linear coefficient of expansion (0.024 mm/m °K)
- l = installed pipe length (m)
- Δt = temperature difference between time of installation and once reached operating temperature (K)

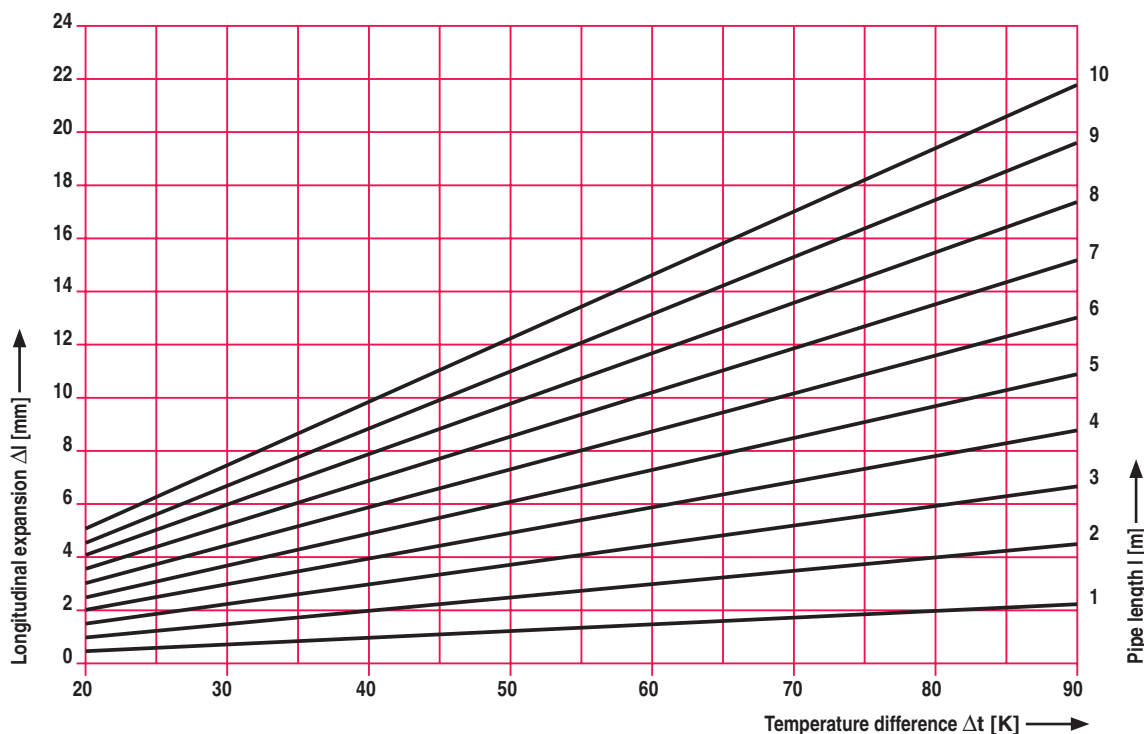

Pipe expansion is compensated by professional laying of the pipes.

Bending legs and fixing distances

Accordingly, with freely laid pipelines or with pipes in protective pipes sufficient bending leg lengths must be ensured for compensatory purposes. When flushmounting or laying into

floor screed (floor heating) the expansion is compensated for radially. The bending leg can be calculated using the calculation method below.

$$BS = c \cdot \sqrt{Da \cdot \Delta l}$$

$c = 33$ (dimensionless material constant)

Da = outer pipe diameter

Δl = change in length

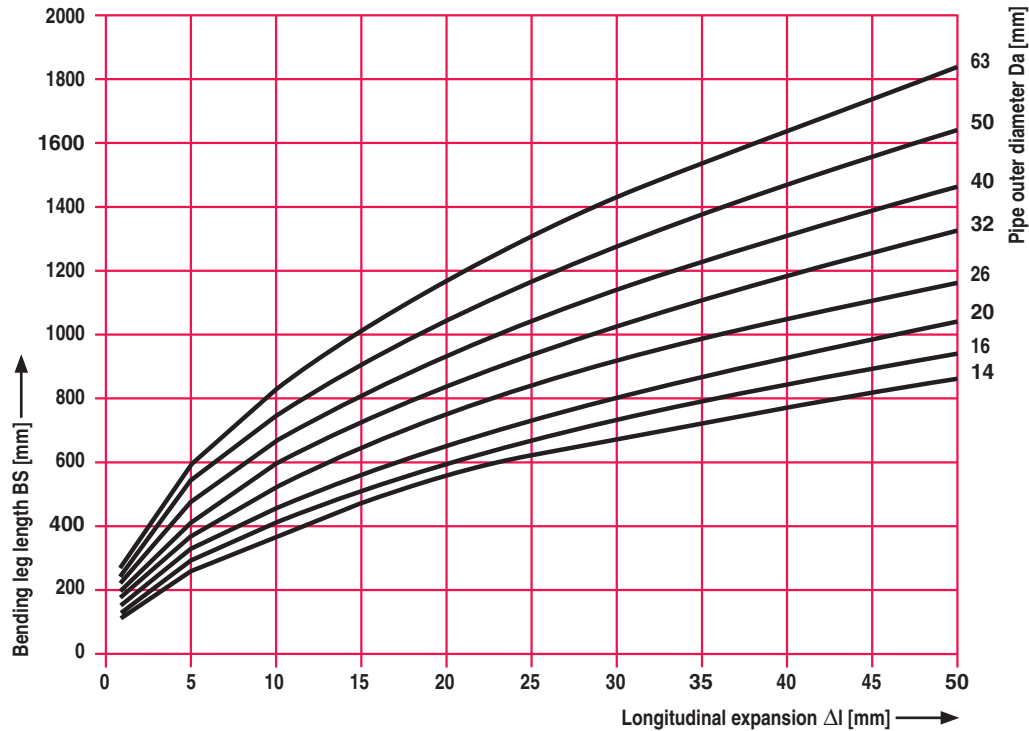

Thanks to their dimensional stability, freely laid pipes do not require any supporting aids like supporting pans, supporting pipes or similar. Information regarding the spacing between the supporting elements can be taken from the table below.

Inlays made of rubber or a similar, soft material should be added to the interior surface of plastic or metal pipe clamps so as to avoid damage to the pipe and also sound transmission.

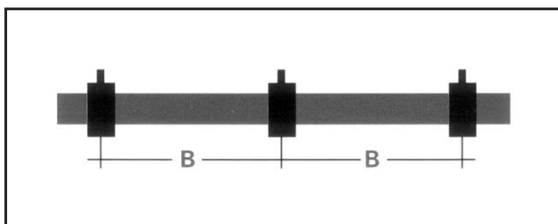

Dimension (mm)	Distance B (m)	Dimension (mm)	Distance B (m)
14	0.8	32	1.6
16	0.8	40	1.7
20	1	50	1.8
26	1.2	63	2

Determining the location of fixed points and slide bearings is very important with pipe laying so as to ensure sufficiently dimensioned bending legs. When it comes to changes in

direction, fittings are generally recommended and a must with dimensions as of DN 32. Pipe expansion can be reduced by 50 % by pretensioning the pipe.

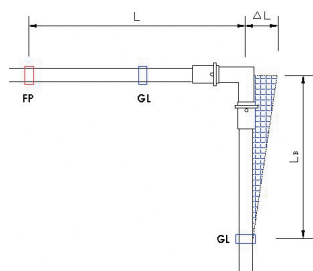

Pipe expansion at change of direction
Bending leg through calculation or from diagram

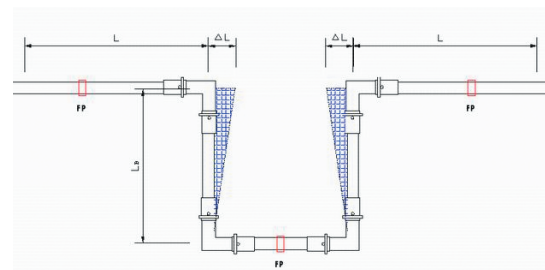

Compensation of pipe expansion with long pipelines
Expansion compensation through U-bow; bending leg through calculation or from diagram

With risers it is recommended to set the fixed point in the middle of the pipeline. This results in smaller dis-

tances between the bending legs.

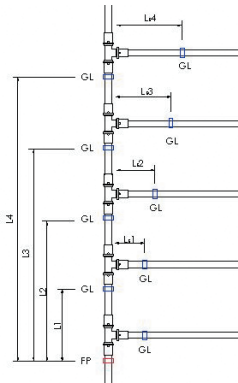

Fixed point at the end of the riser run = bending legs become longer and longer

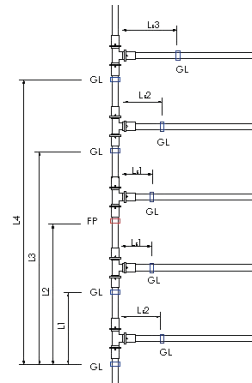

Fixed point in the middle of the riser run = bending legs remain relatively short

With wall and ceiling lead-throughs, protective pipes should be used. In order to avoid a kinking of the pipes,

the pipes must not be bent over sharp edges. Roundings or sufficiently large openings must be ensured.

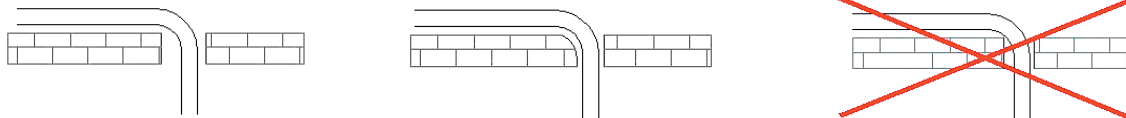

With pipes branches in ducts, correct dimensioning of bending legs must be ensured. If this is impossible to realize, the duct opening must be designed sufficiently

large so as to provide enough space for expansion. It is recommended to install a protective pipe at the duct opening.

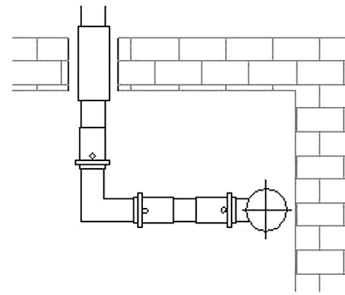
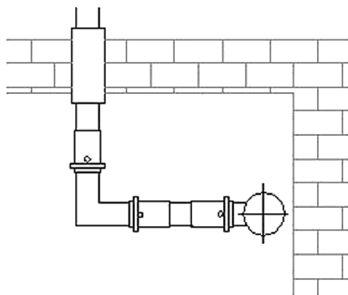

Bending radii

The bending of the pipe can be performed using a bending tool such as an internal spring or an external spring, using a commercially available bending tool or

simply using your hands. The minimum bending radii must be observed without fail. For pipes sized DN 32 or larger, fittings must be used without fail.

DN	With bending tool Radius (mm)	Without bending tool Radius (mm)
16	80	160
20	100	200
26	130	260
32	Use HERZ PipeFix	Use HERZ PipeFix

With a processing temperature of $< +5\text{ }^{\circ}\text{C}$ there's an increased risk of pipes kinking during the bending

process. When bending pipes at temperatures below $+5\text{ }^{\circ}\text{C}$, the relevant pipe sections must be heated.

Pipe bends downstream of a press fitting or a screw connection must have a straight piece of pipe 5 x DN in

length in order to avoid the fittings damage the pipe.

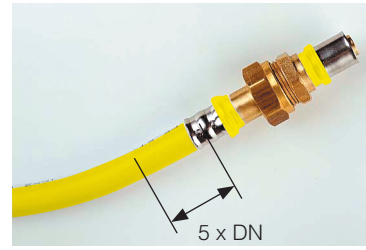
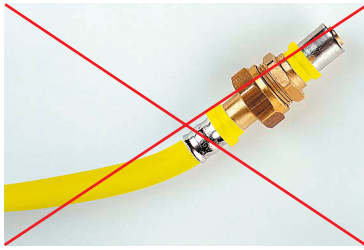

Pipes showing kinks must be replaced without fail.

Processing and operating temperatures

The lowest operating temperatures for PE is $-20\text{ }^{\circ}\text{C}$, the material can be laid at temperatures down to $-40\text{ }^{\circ}\text{C}$. At temperatures below $+5\text{ }^{\circ}\text{C}$, the pipes must not be exposed to excessive external mechanical loads. The pipes must be installed strainless, without bending, tensile or torsional stress. With small bending radii at laying temperatures below $0\text{ }^{\circ}\text{C}$ there's an increased risk of the pipes kinking. We recommend to use bending aids or to heat the relevant pipe sections to a temperature above $+5\text{ }^{\circ}\text{C}$. The press tool must guarantee sufficient press strength also at low temperatures. The relevant tool manufacturer's information must be followed.

Behavior in case of a fire

In addition to aluminum pipes only polyolefin-based plastics are used for the manufacture of HERZ pipes. During normal combustion the same fumes are produced as with a burning candle. Unfavorable conditions (too little oxygen) may lead to carbon monoxide or soot generation, which occurs during every incomplete combustion of organic matter. Aluminum is incombustible under normal conditions. Oxidation products are non-toxic and quite often even part of natural soil composition. No halogens, acids nor other toxic or environmentally harmful materials are released during the combustion of HERZ pipes.

Where fire compartments are crossed, fire protection shutoff devices as per the relevant standards to prevent a fire from spreading must be used. These shutoff devices may be yielding soft partitions, fire protection pads or fire protection sleeves. These partitions shut off the fire compartment once the plastic pipes have burnt down. HERZ plastic pipes fall into fire category B2 (normal flammable building materials) according to DIN 4102, Part 1.

Processing HERZ pipes with HERZ fittings

The pipe is cut to length perpendicular using a suitable tool.

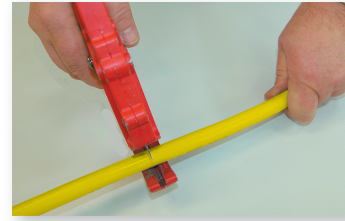

The pipe is trimmed and calibrated with a tool suitable for its diameter. Resulting chips must be removed from the end of the pipe. If the calibrator is fixed in a drilling machine, the maximum rotational speed of 10 RPM must not be exceeded.



Place the fitting on the pipe. Check the correct pipe positioning through the bores on the sleeve – the pipe must be fully engaged on the fitting and be visible through the bores.

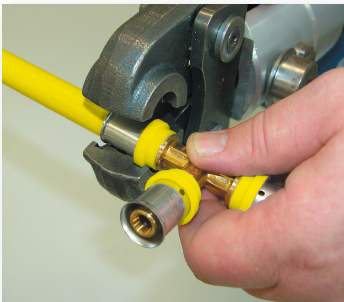

Complete the pressing sealing using a press device or handheld crimping pliers. Pipes must be stainless. The pressing procedure is completed as soon as the jaws have been fully closed.

Press tools are precision tools and must be handled accordingly. HERZ PipeFix must be crimped with the "TH" profile using a commercially available tool (handheld press device, battery-powered press device etc.). Small distances "A" to the wall or floor are possible.

DN	A (mm)	DN	A (mm)
16	25	26	30
20	30	32	40

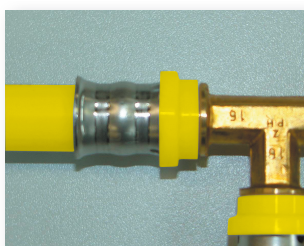
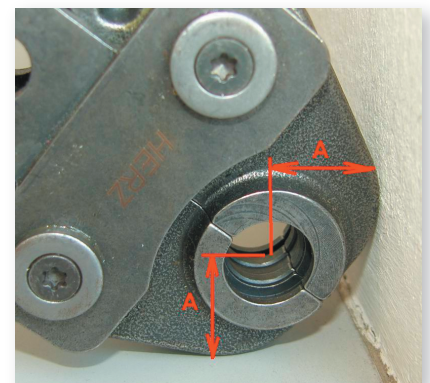

Checking the pressing: On the circumference of the sleeve you can see two parallel, ring-shaped pressed grooves. In between you can see a bulge.

Sophisticated calculation method according to DVGW-TRGI 86/96 for pipe nominal sizes with gas lines:

The maximum admissible total pressure loss between main shutoff device and gas consumer is 260 Pa.

The individual pipelines may show the maximum pressure losses listed below.

- distribution pipe lines from main shutoff device (HAE) to consumer	...	max. 30 Pa
- supply pipes from main shutoff device (HAE) to consumer	...	max. 80 Pa
- branch or device connection lines	...	max. 50 Pa
- risers	...	0 Pa
- gas meters	...	100 Pa

This amounts to a total pressure loss of 260 Pa.

Maximum admissible pressure loss + required connection pressure at the consumer = required gas pressure downstream of the pressure regulator.

Natural gas is lighter than air and therefore rises upwards. In rising pipes we obtain a pressure gain, in downpipes a pressure loss.

This pressure gain or pressure loss is calculated as follows: Height difference * (+ / -) 60 in Pa

With every bowed section, T-piece, reduction, valve etc. a turbulence and thus a pressure loss is introduced. For this reason every resistance must be accounted for. Using the drag coefficient ζ the pressure loss at a certain flow velocity can be determined. A conversion to an equivalent pipe length is also customary. This pipe length as per the matching fitting is then added to the actual pipe length.

The simultaneity of gas consumers must also be considered. The type of gas consumer is decisive here, since e.g. gas stoves are probably used simultaneously before lunchtime rather than continuous-flow water heaters. The hourly gas consumption depends on the nominal heat output of the consumer and is read off at the rating plate or used as per the manufacturer's instructions. If several gas consumers are supplied via one pipeline, the individual volumetric flows are **not** added. The flow rate of one type of device is determined, then the device-specific coincidence factor is calculated. In this way one obtains the device-specific peak flow rate that will occur within this section.



If the gas consumption of all connected consumers is added, the gas line would be dimensioned far to large.

The gas consumers are divided into four groups. The device-specific coincidence factors as well as the gas consumption per nominal heat output can be taken from the TRGI table.

- Group 1: Gas stoves (GH)
- Group 2: Continuous-flow water heaters (DWH)
- Group 3: Room heaters (RH)
- Group 4: Recirculating water heaters (UWH)

After completion of the calculation you need to check that the maximum admissible pressure losses have not been exceeded. It may happen that sections need to be redimensioned.

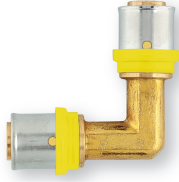
In order to simplify pipe network calculation the drag coefficients of the press fittings can be used as per the equivalent pipe length. This pipe length is taken from the table and added to the actual pipe length during pipe network calculation.

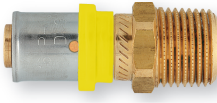
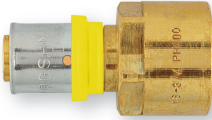
Designation	Image	Dimension (mm)	Equivalent pipe length
Coupling		16	1.2
		20	1.0
		26	1.5
		32	1.5
Angle 90°		16	3.5
		20	3.2
		26	5.0
		32	5.5
Wall angle		16	3.5
		20	3.2
		26	5.0
		32	5.5
Junction with MT		16	1.2
		20	1.0
		26	1.5
Junction with FT		16	1.2
		20	1.0
		26	1.5
		32	1.5

Zeta values see page 11

Existing software for pipe network calculation can also be used for dimensioning and designing the gas pipe networks.

Program for designing interior networks with many branches of natural gas lines, from the building connection to the consumers as per ÖVGW Directive G11. In addition, dimensioning of line lengths as per the simplified procedure for low pressure networks.

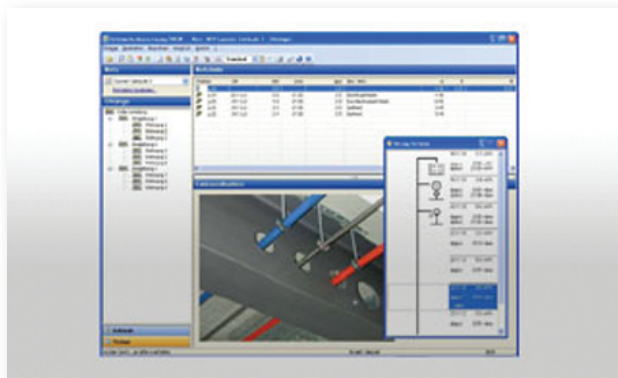

Guideline values for technical building equipment and general calculation formulas

Recommended flow velocities

Low-pressure gas lines	[m/s]	Δp [mbar]
Pipeline to consumer (device connection)	max. 6.0	≤ 0.5
Supply pipe	max. 6.0	≤ 0.8
Distribution pipe line	max. 6.0	≤ 0.3

Designation	Unit	Sign	Calculation formula
Density	kg/m ³	ρ	$\rho = \frac{m}{V}$
Pipe cross section	m ²	A	$A = d^2 \frac{\pi}{4}$
Pipe inner volume	m ³	V	$V = A \cdot l = d^2 \frac{\pi}{4} l$
Flow velocity	m/s	v	$v = \frac{V}{A} = \frac{m}{\rho \cdot A} = \frac{4 \cdot M}{\rho \cdot D^2 \cdot \pi}$
Pressure loss in pipe (gases)	mbar	Δp _R	$\Delta p_R = \frac{p_1 - p_2}{2 \cdot p_1} \lambda \frac{l}{d_i} \frac{\rho}{2} v^2$
Pressure loss through individual resistances	mbar	Z	$Z = \sum \zeta \frac{\rho}{2} v^2$
Pressure drop through pipe friction	mbar/m (gases)	R	$R = \frac{\Delta p_R}{l}$
Total pressure loss		Δp _g	$\Delta p_g = R \cdot l + Z + \Delta p_R$

Leak test and commissioning

Prior to commissioning the gas installation, a leak test of the pipelines without valves, meters, regulators and safety devices must be performed. Valves may be included in the test if the maximum operating pressure (MOP) at least equals the test pressure.

The test pressure is set to 150 mbars, the test duration depends on the system contents as per the temperature equalization time. The pressure in the pipe system must not drop during the test duration.

Line volume	Equalization time	Test duration
< 100 liters	10 minutes	10 minutes
100 to 200 liters	30 minutes	20 minutes
> 200 liters	60 minutes	30 minutes

Prior to commissioning all line openings must be closed. Gas is introduced into the lines until the air has been removed from the pipe system. Leaking lines must not be charged with gas.

The gas system operator is obliged to ensure trouble-free operation and to adhere to all inspections and maintenance intervals regularly required by the gas supply company.



PRESSURE TEST PROTOCOL

for low pressure gas installation

Building owner: _____ Installation company: _____

Address: _____ Construction supervisor / inspector: _____

Installation pressure: _____ mbar (< 100 mbar = low pressure)

Test medium: compressed air nitrogen

Tested as complete installation sections

Dimension	Contents
16 x 2.0	0.113
20 x 2.0	0.201
26 x 3.0	0.314
32 x 3.0	0.531

Test pressure: mbars (150 mbars)

Test duration: minutes equalization time minutes test duration (acc. to table)

Test pressure did not drop.













Visual inspection of tested installation, tested for leak-tightness using leak detection spray or foaming agent





No leaks have been found.

Place, date: _____ Company stamp _____ Signature of inspector _____

Pressure measuring devices have been used that allow adequate reading of pressure changes of 0.1 mbars.
Leaking installations must not be commissioned!





Valves for gas systems from the HERZ product range

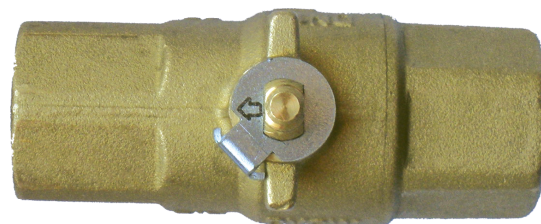

Description	Dim.	PN	MOP	Order number
 <p>Ball valve with sheet steel hand lever brass body as per EN 12165, with O-ring seal for ball and spindle, threaded sleeve on both ends. Suitable for gas installations as per ÖVGW nominal pressure PN 1 (high temperature range 650 °C / 30 min), operating temperature -20 °C to +60 °C</p> 	DN 8	1	5	1 2300 29
	DN 10			1 2300 20
	DN 15			1 2300 21
	DN 20			1 2300 22
	DN 25			1 2300 23
	DN 32			1 2300 24
	DN 40			1 2300 25
DN 50	1 2300 26			
 <p>Ball valve with sheet steel T-handle brass body as per EN 12165, with O-ring seal for ball and spindle, threaded sleeve on both ends. Suitable for gas installations as per ÖVGW nominal pressure PN 1 (high temperature range 650 °C / 30 min), operating temperature -20 °C to +60 °C</p> 	DN 8	1	5	1 2300 39
	DN 10			1 2300 30
	DN 15			1 2300 31
	DN 20			1 2300 32
	DN 25			1 2300 33
DN 32	1 2300 34			
 <p>Ball valve with sheet steel hand lever brass body as per EN 12165, with O-ring seal for ball and spindle, threaded sleeve on both ends. Suitable for gas installations as per DIN-DVGW G 260 nominal pressure PN 1 (high temperature range 650 °C / 30 min), operating temperature -20 °C to +60 °C</p> 	DN 8	1	5	1 2300 09
	DN 10			1 2300 00
	DN 15			1 2300 01
	DN 20			1 2300 02
	DN 25			1 2300 03
	DN 32			1 2300 04
	DN 40			1 2300 05
DN 50	1 2300 06			
 <p>Ball valve with sheet steel T-handle brass body as per EN 12165, with O-ring seal for ball and spindle, threaded sleeve on both ends. Suitable for gas installations as per DIN-DVGW G 260 nominal pressure PN 1 (high temperature range 650 °C / 30 min), operating temperature -20 °C to +60 °C</p> 	DN 8	1	5	1 2300 19
	DN 10			1 2300 10
	DN 15			1 2300 11
	DN 20			1 2300 12
	DN 25			1 2300 13
DN 32	1 2300 14			
 <p>Ball valve with sheet steel T-handle brass body as per EN 12165, with O-ring seal for ball and spindle, FT x MT. Suitable for gas installations as per DIN-DVGW G 260 nominal pressure PN 1 (high temperature range 650 °C / 30 min), operating temperature -20 °C to +60 °C</p> 	DN 8	1	5	1 2301 09
	DN 10			1 2301 00
	DN 15			1 2301 01
	DN 20			1 2301 02
	DN 25			1 2301 03
	DN 32			1 2301 04
	DN 40			1 2301 05
DN 50	1 2301 06			
 <p>Ball valve with sheet steel T-handle brass body as per EN 12165, with O-ring seal for ball and spindle, FT x MT. Suitable for gas installations as per DIN-DVGW G 260 nominal pressure PN 1 (high temperature range 650 °C / 30 min), operating temperature -20 °C to +60 °C</p> 	DN 8	1	5	1 2301 19
	DN 10			1 2301 10
	DN 15			1 2301 11
	DN 20			1 2301 12
	DN 25			1 2301 13
DN 32	1 2301 14			



Description	Dim.	PN	MOP	Order number
 <p>Ball valve with sheet steel hand lever brass body as per EN 12165, with O-ring seal for ball and spindle, threaded sleeve on both ends. Suitable for gas installations as per DIN-DVGW G 260 nominal pressure PN 1, operating temperature -20 °C to +60 °C, with thermal valve protection (TAS) resistant to 925 °C / 60 min</p> 	DN 15	1	5	1 2302 01
	DN 20			1 2302 02
	DN 25			1 2302 03
 <p>Ball valve with sheet steel T-handle brass body as per EN 12165, with O-ring seal for ball and spindle, threaded sleeve on both ends. Suitable for gas installations as per DIN-DVGW G 260 nominal pressure PN 1, operating temperature -20 °C to +60 °C, with thermal valve protection (TAS) resistant to 925 °C / 60 min</p> 	DN 15	1	5	1 2302 11
	DN 20			1 2302 12
	DN 25			1 2302 13
 <p>Ball valve with sheet steel T-handle brass body as per EN 12165, with O-ring seal for ball and spindle, FT x MT, flat sealing. Nominal pressure PN 1 (high temperature range 650 °C / 30 min), operating temperature -20 °C to +60 °C</p>	DN 8	1	5	1 2303 09
	DN 10			1 2303 00
	DN 15			1 2303 01
	DN 20			1 2303 02
	DN 25			1 2303 03
	DN 32			1 2303 04
	DN 40			1 2303 05
	DN 50			1 2303 06

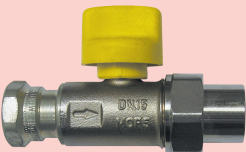

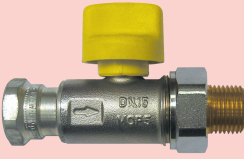
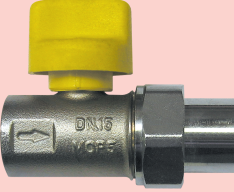
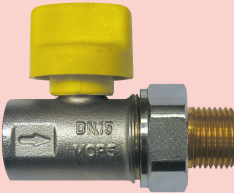



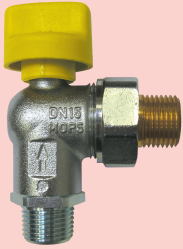
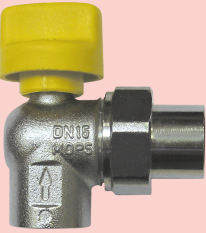
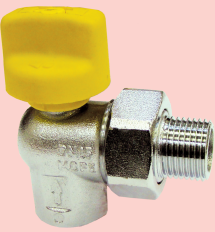

Position indicator as per ÖVGW
Determining the position without hand lever

Description		Dim.	PN	MOP	Order number
	Ball valve with sheet steel hand lever brass body as per EN 12165, with O-ring seal for ball and spindle, FT x MT, flat sealing. Nominal pressure PN 1, operating pressure -20 °C to +60 °C, with thermal valve protection (TAS) resistant to 925 °C / 60 min	DN 8	1	5	1 2303 19
		DN 10			1 2303 10
		DN 15			1 2303 11
		DN 20			1 2303 12
		DN 25			1 2303 13
		DN 32			1 2303 14
	Ball valve for device connection with plastic handle, angle version brass body as per EN 12165, nickel-plated, with double O-ring seal for spindle, ball valve with Teflon seal, MT on both ends, safe operation be pressing down and turning of handle. Nominal pressure PN 5, operating temperature -20 °C to +60 °C	DN 10	1	5	1 2362 00
	Ball valve for device connection with plastic handle, angle version brass body as per EN 12165, nickel-plated, with double O-ring seal for spindle, ball with Teflon seal, FT x MT, safe operation be pressing down and turning of handle. Nominal pressure PN 5, operating temperature -20 °C to +60 °C	DN 10	1	5	1 2372 01
	Ball valve for device connection with T-handle, angle version brass body as per EN 12165, nickel-plated, with double O-ring seal for spindle, ball valve with Teflon seal, MT on both ends, nominal pressure PN 5, operating temperature -20 °C to +60 °C	DN 10	1	5	1 2362 10
	Ball valve for device connection with T-handle, angle version brass body as per EN 12165, nickel-plated, with double O-ring seal for spindle, Ball with Teflon seal, FT x MT, nominal pressure PN 5, operating temperature -20 °C to +60 °C	DN 10	1	5	1 2372 11
	Ball valve for device connection with plastic handle, straightway version brass body as per EN 12165, nickel-plated, with double O-ring seal for spindle, ball with Teflon seal, FT x conically sealing screw connection with weld stud, safety operation by pressing down and turning of handle. DVGW approval pending nominal pressure PN 1, operating pressure -20 °C to +60 °C, with thermal valve protection (TAS) resistant to 925 °C / 60 min	DN 15	1	5	1 2362 21
		DN 20			1 2362 22
		DN 25			1 2362 23

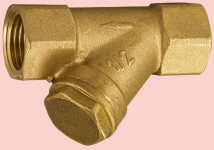
Description	Dim.	PN	MOP	Order number
 <p>Ball valve for device connection with plastic handle, straightway version brass body as per EN 12165, nickel-plated, with double O-ring seal for spindle, ball with Teflon seal, FT x conically sealing iron pipe connection, safety operation by pressing down and turning of handle. DVGW approval pending nominal pressure PN 1, operating pressure -20 °C to +60 °C, with thermal valve protection (TAS) resistant to 925 °C / 60 min</p>	DN 15	1	5	1 2362 31
 <p>Ball valve for device connection with plastic handle, straightway version brass body as per EN 12165, nickel-plated, with double O-ring seal for spindle, ball with Teflon seal, FT x conically sealing screw connection with weld stud, safe operation be pressing down and turning of handle. DVGW approval pending nominal pressure PN 1, operating pressure -20 °C to +60 °C, with thermal valve protection (TAS) resistant to 650 °C / 30 min</p>	DN 15	1	5	1 2363 01
 <p>Ball valve for device connection with plastic handle, straightway version brass body as per EN 12165, nickel-plated, with double O-ring seal for spindle, ball with Teflon seal, FT x conically sealing iron pipe connection, safety operation by pressing down and turning of handle. DVGW approval pending nominal pressure PN 1, operating pressure -20 °C to +60 °C, with thermal valve protection (TAS) resistant to 650 °C / 30 min</p>	DN 15	1	5	1 2363 11
 <p>Ball valve for device connection with plastic handle, angle version brass body as per EN 12165, nickel-plated, with double O-ring seal for spindle, ball with Teflon seal, MT x conically sealing screw connection with weld stud, safe operation be pressing down and turning of handle. DVGW approval pending nominal pressure PN 1, operating pressure -20 °C to +60 °C, with thermal valve protection (TAS) resistant to 925 °C / 60 min</p>	DN 15	1	5	1 2362 41
	DN 20			1 2362 42
	DN 25			1 2362 43







Description	Dim.	PN	MOP	Order number
 <p>Ball valve for device connection with plastic handle, angle version brass body as per EN 12165, nickel-plated, with double O-ring seal for spindle, ball with Teflon seal, MT x conically sealing iron pipe connection, safety operation by pressing down and turning of handle. DVGW approval pending nominal pressure PN 1, operating pressure -20 °C to +60 °C, with thermal valve protection (TAS) resistant to 925 °C / 60 min</p>	DN 15	1	5	1 2362 51
 <p>Ball valve for device connection with plastic handle, angle version brass body as per EN 12165, nickel-plated, with double O-ring seal for spindle, ball with Teflon seal, FT x conically sealing screw connection with weld stud, safety operation by pressing down and turning of handle. DVGW approval pending nominal pressure PN 1, operating pressure -20 °C to +60 °C, with thermal valve protection (TAS) resistant to 650 °C / 30 min</p>	DN 15	1	5	1 2363 21
 <p>Ball valve for device connection with plastic handle, angle version brass body as per EN 12165, nickel-plated, with double O-ring seal for spindle, ball with Teflon seal, FT x conically sealing iron pipe connection, safety operation by pressing down and turning of handle. DVGW approval pending nominal pressure PN 1, operating pressure -20 °C to +60 °C, with thermal valve protection (TAS) resistant to 650 °C / 30 min</p>	DN 15	1	5	1 2363 31
 <p>Ball valve with sheet steel hand lever brass body as per EN 12165, nickel-plated, with double O-ring seal for spindle, ball valve with Teflon seal, threaded sleeve on both ends. Nominal pressure PN 4, operating temperature -20 °C to +60 °C</p>	DN 10	4		1 2304 00
	DN 15			1 2304 01
	DN 20			1 2304 02
	DN 25			1 2304 03
	DN 32			1 2304 04
	DN 40			1 2304 05
 <p>Ball valve with sheet steel T-handle brass body as per EN 12165, nickel-plated, with double O-ring seal for spindle, ball valve with Teflon seal, threaded sleeve on both ends. Nominal pressure PN 4, operating temperature -20 °C to +60 °C</p>	DN 10	4		1 2304 10
	DN 15			1 2304 11
	DN 20			1 2304 12
	DN 25			1 2304 13
	DN 32			1 2304 14







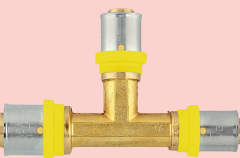

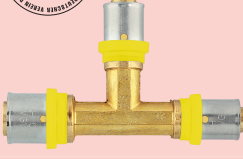

Description		Dim.	PN	MOP	Order number
	Ball valve with sheet steel hand lever brass body as per EN 12165, nickel-plated, with double O-ring seal for spindle, ball with Teflon seal, FT x MT, nominal pressure PN 4, operating temperature -20 °C to +60 °C	DN 10	4		1 2305 00
		DN 15			1 2305 01
		DN 20			1 2305 02
		DN 25			1 2305 03
		DN 32			1 2305 04
		DN 40			1 2305 05
		DN 50			1 2305 06
	Insulating nipple brass body as per EN 12165, FT x MT suitable for gas installations as per DIN-DVGW, table G 260. Nominal pressure PN 5, operating pressure -20 °C to +60 °C	DN 15	5		1 2000 01
		DN 20			1 2000 02
		DN 25			1 2000 03
		DN 32			1 2000 04
		DN 40			1 2000 05
		DN 50			1 2000 06
	Strainer for gas brass body as per EN 12165, threaded sleeve on both ends, suitable for gas installations as per DIN-DVGW, table G 260. Nominal pressure PN 5, operating temperature -20 °C to +60 °C	DN 15	5		1 2319 01
		DN 20			1 2319 02
		DN 25			1 2319 03

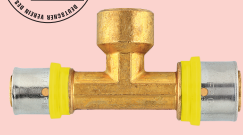
Description	Dim.	PN	MOP	Order number
 <p>Composite plastic aluminum pipe on reels, 0.4 mm aluminum coating, natural gas tight and resistant to admissible impurities, pipe outer coating in yellow RAL 1201 operating temperature -20 °C to +60 °C, max. operating pressure 100 mbars</p> 	16 x 2.0	0.1		G 1160 20
	20 x 2.0	0.1		G 1200 20
	26 x 3.0	0.1		G 1260 20
	32 x 3.0	0.1		G 1320 20
 <p>Composite plastic aluminum pipe rods of 5 m each, 0.4 mm aluminum coating, natural gas tight and resistant to admissible impurities, pipe outer coating in yellow RAL 1201 operating temperature -20 °C to +60 °C, max. operating pressure 100 mbars</p> 	16 x 2.0	0.1		G 1160 21
	20 x 2.0	0.1		G 1200 21
	26 x 3.0	0.1		G 1260 21
	32 x 3.0	0.1		G 1320 21

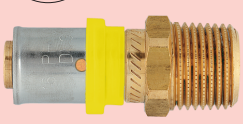
Brass press fittings for natural gas

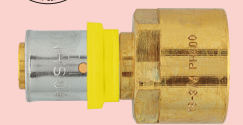
Stainless steel sleeve, HNBR double O-ring, yellow,
Plastic ring for sleeve centering, yellow,
operating temperature -20 °C to +60 °C, max. operating pressure 100 mbars

 	Straight coupling	16 x 2.0	0.1		G 17016 00
		20 x 2.0	0.1		G 17020 00
		26 x 3.0	0.1		G 17026 00
		32 x 3.0	0.1		G 17032 00
 	Reduction	20 x 2.0 - 16 x 2.0	0.1		G 17020 01
		26 x 3.0 - 16 x 2.0	0.1		G 17026 01
		26 x 3.0 - 20 x 2.0	0.1		G 17026 02
		32 x 3.0 - 16 x 2.0	0.1		G 17032 02
		32 x 3.0 - 20 x 2.0	0.1		G 17032 06
 	T-piece	16 x 2.0	0.1		G 17216 00
		20 x 2.0	0.1		G 17220 00
		26 x 3.0	0.1		G 17226 00
		32 x 3.0	0.1		G 17232 00
	T-piece reduced	16 x 2.0 - 20 x 2.0 - 16 x 2.0	0.1		G 17216 03
		26 x 3.0 - 32 x 3.0 - 26 x 3.0	0.1		G 17226 17
		20 x 2.0 - 16 x 2.0 - 20 x 2.0	0.1		G 17220 01
		26 x 3.0 - 16 x 2.0 - 26 x 3.0	0.1		G 17226 03
		26 x 3.0 - 20 x 2.0 - 26 x 3.0	0.1		G 17226 05
		32 x 3.0 - 20 x 2.0 - 32 x 3.0	0.1		G 17232 04
		32 x 3.0 - 26 x 2.0 - 32 x 3.0	0.1		G 17232 07

Description	Dim.	PN	MOP	Order number
 	T-piece reduced	20 x 2.0 - 16 x 2.0- 16 x 2.0	0.1	G 17220 03
	26 x 3.0 - 20 x 2.0 - 16 x 2.0	0.1	G 17226 13	
	32 x 3.0 - 26 x 3.0 - 26 x 3.0	0.1	G 17232 09	
	32 x 3.0 - 32 x 3.0 - 26 x 3.0	0.1	G 17232 14	
 	T-piece with female thread (FT)	16 x 2.0 - 1/2 - 16 x 2.0	0.1	G 17216 41
	20 x 2.0 - 1/2 - 20 x 2.0	0.1	G 17220 41	
	26 x 3.0 - 1/2 - 26 x 3.0	0.1	G 17226 41	
	32 x 3.0 - 1/2 - 32 x 3.0	0.1	G 17232 43	
 	Junction with male thread (MT)	16 x 2.0 - R 1/2	0.1	G 17016 11
	20 x 2.0 - R 1/2	0.1	G 17020 11	
	20 x 2.0 - R 3/4	0.1	G 17020 12	
	26 x 3.0 - R 3/4	0.1	G 17026 12	
	32 x 3.0 - R 1	0.1	G 17032 13	
 	Junction with female thread (FT)	16 x 2.0 - Rp 1/2	0.1	G 17016 21
	20 x 2.0 - Rp 1/2	0.1	G 17020 21	
	20 x 2.0 - Rp 3/4	0.1	G 17020 22	
	26 x 3.0 - Rp 3/4	0.1	G 17026 22	
	26 x 3.0 - Rp 1	0.1	G 17026 23	
	32 x 3.0 - Rp 1 1/4	0.1	G 17032 24	
 	Angle 90°	16 x 2.0	0.1	G 17116 00
	20 x 2.0	0.1	G 17120 00	
	26 x 3.0	0.1	G 17126 00	
	32 x 3.0	0.1	G 17132 00	
 	Wall angle, short	16 x 2.0 - R 1/2	0.1	G 17116 31
	20 x 2.0 - R 1/2	0.1	G 17120 31	
	20 x 2.0 - R 3/4	0.1	G 17120 32	
	26 x 3.0 - R 3/4	0.1	G 17126 32	

Ball valve for gas

with sheet steel hand lever or T-handle
high temperature range 650 °C, 30 min
Standard sheet for **2300**, issue 0209

Dimensions

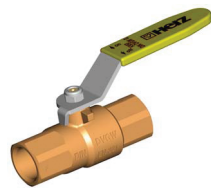

1 2300 0x

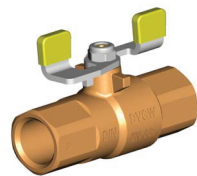

1 2300 1x

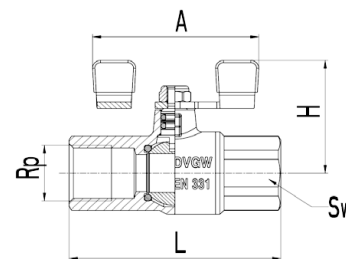
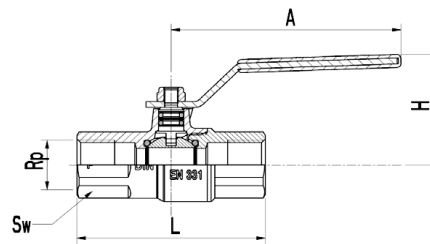

Order number	Operating pressure	PN	DN	Rp	L	H	A/B	Connection torque (Nm)	Width across flats	Weight kg
1 2300 09	5	1	8	1/4	55	41	70	20	17	0.145
1 2300 19							60			
1 2300 00	5	1	10	3/8	60	41	70	35	21	0.180
1 2300 10							60			
1 2300 01	5	1	15	1/2	75	43	90	75	26	0.275
1 2300 11							60			
1 2300 02	5	1	20	3/4	80	47	90	100	32	0.395
1 2300 12							60			
1 2300 03	5	1	25	1	90	61	135	125	41	0.725
1 2300 13							85			
1 2300 04	5	1	32	1 1/4	110	66	135	160	50	1.175
1 2300 14							85			
1 2300 05	5	1	40	1 1/2	120	86	180	200	55	1.830
1 2300 06	5	1	50	2	140	90	180	250	70	3.000

Version

- Body: brass as per EN 12165
- Ball: forged brass, full opening, machine-polished and chrome-plated
- Spindle: brass
- Hand lever: sheet steel with plastic cover
- Thread: female thread according to ISO 7-1 (DIN 2999, BS 21)
- Seals: NBR, 80 Shore for ball, NBR 70 Shore for spindle

Technical data

- Maximum operating pressure: MOP 5 (EN 331), PN 1 (high temperature range 650 °C)
- Maximum operating temperature: -20 °C to 60 °C
- Application: for gases of gas families 1, 2, 3 according to EN 437 (DVGW table G 260/1)

Application

The ball valve is used as an "OPEN/CLOSED" type isolating valve with gas installations as per DVGW-TRGI, G 260/I. Areas of application include gas-fired heating systems, water heaters upstream of the consumer. In the case of a fire the seal will burn down due to the high fire temperature. In this case, the sealing between ball and body using is ensured by the remaining metal seal. At a temperature of 650 °C the valve remains closed for 30 minutes. The ball valve is used as a safety valve in gas installations.

Installation

For the threaded connection commercially available sealing materials such as hemp fiber and sealing compound or Teflon tapes are used. The indicated maximum connection torque must not be exceeded when screwing in the pipe ends. The ball valve is positioned upstream of the consumers as a means of fire protection. We recommend to exclusively use the ball valve either in the fully opened or fully closed position, never in intermediate positions. The ball valve is maintenance-free, however, it is recommended to operate it 2 times a year.

Ball valve for gas

with sheet steel hand lever or T-handle
high temperature range 650 °C, 30 min

 Standard sheet for **2301**, issue 0209

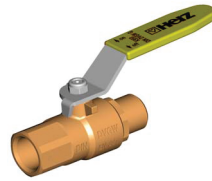
Dimensions

1 2301 0x

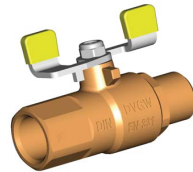
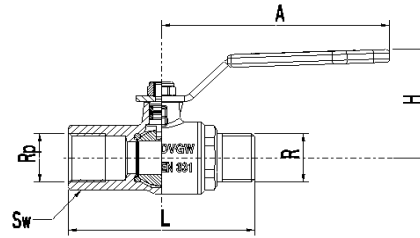

1 2301 1x

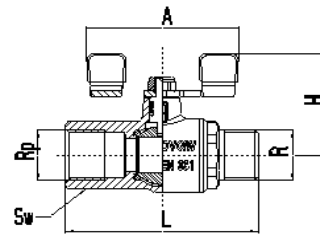

Order number	Operating pressure	PN	DN	Rp/R	L	H	A/B	Connection torque (Nm)	Width across flats	Weight kg
1 2301 09	5	1	8	1/4	55	41	70	20	17	0.145
1 2301 19							60			
1 2301 00	5	1	10	3/8	60	41	70	35	21	0.180
1 2301 10							60			
1 2301 01	5	1	15	1/2	75	43	90	75	26	0.275
1 2301 11							60			
1 2301 02	5	1	20	3/4	80	47	90	100	32	0.395
1 2301 12							60			
1 2301 03	5	1	25	1	90	61	135	125	41	0.725
1 2301 13							85			
1 2301 04	5	1	32	1 1/4	110	66	135	160	50	1.175
1 2301 14							85			
1 2301 05	5	1	40	1 1/2	120	86	180	200	55	1.830
1 2301 06	5	1	50	2	140	90	180	250	70	3.000

Version

Body: brass as per EN 12165
 Ball: forged brass, full opening, machine-polished and chrome-plated
 Spindle: brass
 Hand lever: sheet steel with plastic cover
 Thread: female thread according to ISO 7-1 (DIN 2999, BS 21)
 Seals: NBR, 80 Shore for ball, NBR 70 Shore for spindle

Technical data

Maximum operating pressure: MOP 5 (EN 331), PN 1 (high temperature range 650 °C)
 Maximum operating temperature: -20 °C to 60 °C
 Application: for gases of gas families 1, 2, 3 according to EN 437 (DVGW table G 260/1)

Application

The ball valve is used as an "OPEN/CLOSED" type isolating valve with gas installations as per DVGW-TRGI, G 260/I. Areas of application include gas-fired heating systems, water heaters upstream of the consumer. In the case of a fire the seal will burn down due to the high fire temperature. In this case, the sealing between ball and body using is ensured by the remaining metal seal. At a temperature of 650 °C the valve remains closed for 30 minutes. The ball valve is used as a safety valve in gas installations.

Installation

For the threaded connection commercially available sealing materials such as hemp fiber and sealing compound or Teflon tapes are used. The indicated maximum connection torque must not be exceeded when screwing in the pipe ends. The ball valve is positioned upstream of the consumers as a means of fire protection. We recommend to exclusively use the ball valve either in the fully opened or fully closed position, never in intermediate positions. The ball valve is maintenance-free, however, it is recommended to operate it 2 times a year.

Safety ball valve for gas with sheet steel hand lever or T-handle

TAS 925 °C, 60 min

Standard sheet for **2302**, issue 0209

Dimensions

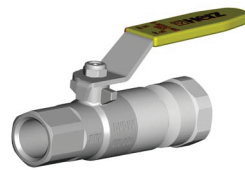

1 2302 0x

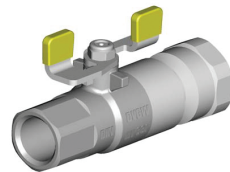

1 2302 1x

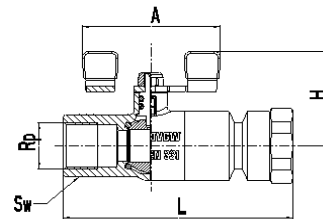
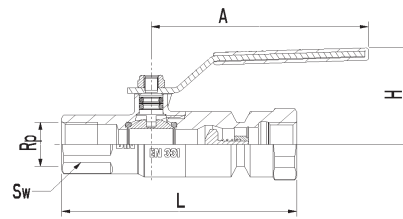

Order number	Operating pressure	PN	DN	Rp	L	H	A/B	Connection torque (Nm)	Width across flats	Weight
1 2302 01	5	1	15	1/2	98	45	90	75	26	0.40
1 2302 11							60			
1 2302 02	5	1	20	3/4	107	49	90	100	32	0.60
1 2302 12							60			
1 2302 03	5	1	25	1	133	61	135	125	41	1.25
1 2302 13							85			

Version

- Body: brass as per EN 12165, nickel-plated
- Ball: forged brass, full opening, machine-polished and chrome-plated
- Spindle: brass
- Hand lever: sheet steel with plastic cover
- Thread: nickel-plated steel, brass, female thread according to ISO 7-1 (DIN 2999, BS 21)
- Seals: NBR, 80 Shore for ball, NBR 70 Shore for spindle

Technical data

- Maximum operating pressure: MOP 5 (EN 331), PN 1
- Maximum operating temperature: -20 °C to 60 °C
- Triggering temperature: 85 °C to 115 °C
- Application: for gases of gas families 1, 2, 3 according to EN 437 (DVGW table G 260/1)

Application

The ball valve is used as an "OPEN/CLOSED" type isolating valve with gas installations as per DVGW-TRGI, G 260/I. Areas of application include gas-fired heating systems, water heaters upstream of the consumer. In case of a fire or at an ambient temperature of 85 °C to 115 °C, the valve is automatically closed by a thermally-activated triggering element and spring force. At a temperature of 925 °C, the valve remains closed for 60 minutes even after cooling down. The ball valve is used as a safety valve in gas installations.

Installation

For the threaded connection commercially available sealing materials such as hemp fiber and sealing compound or Teflon tapes are used. The indicated maximum connection torque must not be exceeded when screwing in the pipe ends. The flow direction is indicated by an arrow and must be adhered to. The ball valve is positioned upstream of the consumers as a means of fire protection. We recommend to exclusively use the ball valve either in the fully opened or fully closed position, never in intermediate positions. The ball valve is maintenance-free, however, it is recommended to operate it 2 times a year.

Ball valve for gas

with sheet steel hand lever or T-handle

high temperature range 925 °C, 30 min

Standard sheet for **2303**, issue 0209

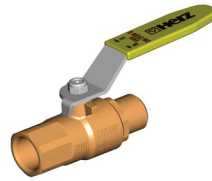
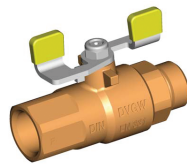
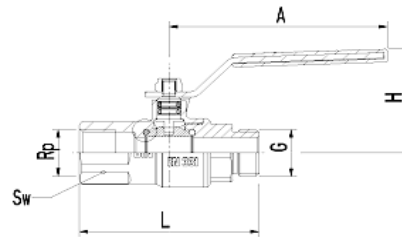
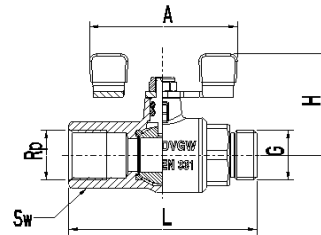
☑ Dimensions

1 2303 0x

1 2303 1x

Order number	Operating pressure	PN	DN	Rp/G	L	H	A/B	Connection torque (Nm)	Width across flats	Weight
1 2303 09	5	1	8	1/4	55	41	70	20	17	0.145
1 2303 19							60			
1 2303 00	5	1	10	3/8	60	41	70	35	21	0.180
1 2303 10							60			
1 2303 01	5	1	15	1/2	75	43	90	75	26	0.275
1 2303 11							60			
1 2303 02	5	1	20	3/4	80	47	90	100	32	0.395
1 2303 12							60			
1 2303 03	5	1	25	1	90	61	135	125	41	0.725
1 2303 13							85			
1 2303 04	5	1	32	1 1/4	110	66	135	160	50	1.175
1 2303 14							85			
1 2303 05	5	1	40	1 1/2	120	86	180	200	55	1.830
1 2303 06	5	1	50	2	137	90	180	250	70	3.000

☑ Version

Body: brass as per EN 12165
 Ball: forged brass, full opening, machine-polished and chrome-plated
 Spindle: brass
 Hand lever: sheet steel with plastic cover
 Thread: female thread according to ISO 7-1 (DIN 2999, BS 21), male thread G ISO 228
 Seals: NBR, 80 Shore for ball, NBR 70 Shore for spindle

☑ Technical data

Maximum operating pressure: MOP 5 (EN 331), PN 1 (high temperature range 650 °C)
 Maximum operating temperature: -20 °C to 60 °C
 Application: for gases of gas families 1, 2, 3 according to EN 437 (DVGW table G 260/1)

☑ Application

The ball valve is used as an "OPEN/CLOSED" type isolating valve with gas installations as per DVGW-TRGI, G 260/I. Areas of application include gas-fired heating systems, water heaters upstream of the consumer. In the case of a fire the seal will burn down due to the high fire temperature. In this case, the sealing between ball and body using is ensured by the remaining metal seal. At a temperature of 650 °C the valve remains closed for 30 minutes. The ball valve is used as a safety valve in gas installations.

☑ Installation

For the threaded connection commercially available sealing materials such as hemp fiber and sealing compound or Teflon tapes are used. The indicated maximum connection torque must not be exceeded when screwing in the pipe ends. The ball valve is positioned upstream of the consumers as a means of fire protection. We recommend to exclusively use the ball valve either in the fully opened or fully closed position, never in intermediate positions. The ball valve is maintenance-free, however, it is recommended to operate it 2 times a year.

Ball valve for gas

with sheet steel hand lever or T-handle

Standard sheet for **2304**, issue 0209

☑ Dimensions



1 2304 0x

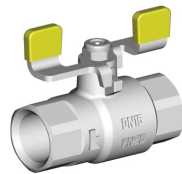
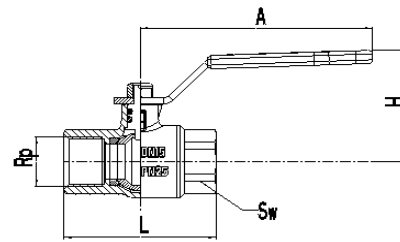

1 2304 1x

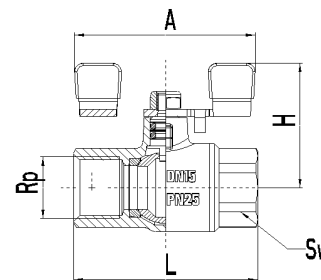

Order number	PN	DN	Rp	L	H	A/B	Connection torque (Nm)	Width across flats	Weight kg
1 2304 00	4	10	3/8	50	40	70	35	21	0.145
1 2304 10						60			
1 2304 01	4	15	1/2	60	45	90	75	25	0.220
1 2304 11						60			
1 2304 02	4	20	3/4	68	48	90	100	31	0.320
1 2304 12						60			
1 2304 03	4	25	1	81	61	135	125	39	0.600
1 2304 13						85			
1 2304 04	4	32	1¼	95	65	135	160	48	0.960
1 2304 14						85			
1 2304 05	4	40	1½	106	86	180	200	55	1.275
1 2304 06	4	50	2	127	92	180	250	68	2.550

☑ Version

Body: brass as per EN 12165, nickel-plated
 Ball: forged brass, full opening, machine-polished and chrome-plated
 Spindle: brass
 Hand lever: sheet steel with plastic cover
 Thread: female thread according to ISO 7-1 (DIN 2999, BS 21)
 Seals: PTFE for ball, NBR 70 Shore for spindle

☑ Technical data

Maximum operating pressure: PN 4 bars (PN 25 for other, non-aggressive media)
 Maximum operating temperature: -20 °C to 60 °C
 Application: for gases of gas families 1, 2, 3 according to EN 437 (DVGW table G 260/1)

☑ Application

The ball valve is used as an "OPEN/CLOSED" type isolating valve with gas installations as per DVGW-TRGI, G 260/I. Areas of application include gas-fired heating systems, water heaters upstream of the consumer. The ball valve is used as a safety valve in gas installations.

☑ Installation

For the threaded connection commercially available sealing materials such as hemp fiber and sealing compound or Teflon tapes are used. The indicated maximum connection torque must not be exceeded when screwing in the pipe ends. We recommend to exclusively use the ball valve either in the fully opened or fully closed position, never in intermediate positions. The ball valve is maintenance-free, however, it is recommended to operate it 2 times a year.

Ball valve for gas

with sheet steel hand lever or T-handle

 Standard sheet for **2305**, issue 0209

☑ Dimensions

1 2305 0x

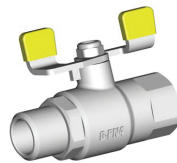
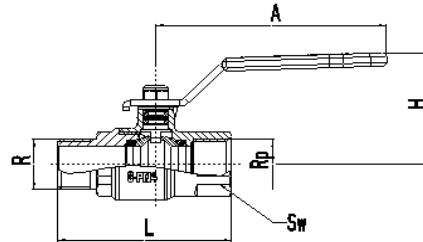

1 2305 1x

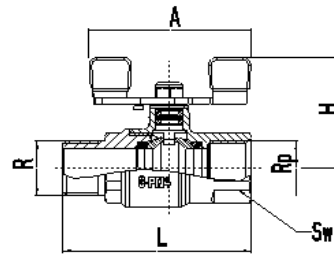

Order number	PN	DN	R/Rp	L	H	A/B	Connection torque (Nm)	Width across flats	Weight kg
1 2305 00	4	10	3/8	50	40	70	35	21	0.150
1 2305 10						60			
1 2305 01	4	15	1/2	69	45	90	75	25	0.230
1 2305 11						60			
1 2305 02	4	20	3/4	74	48	90	100	31	0.330
1 2305 12						60			
1 2305 03	4	25	1	88	61	135	125	39	0.625
1 2305 13						85			
1 2305 04	4	32	1¼	103	65	135	160	48	1.000
1 2305 14						85			
1 2305 05	4	40	1½	110	86	180	200	55	1.600
1 2305 06	4	50	2	128	92	180	250	68	2.660

☑ Version

Body: brass as per EN 12165, nickel-plated
 Ball: forged brass, full opening, machine-polished and chrome-plated
 Spindle: brass
 Hand lever: sheet steel with plastic cover
 Thread: thread according to ISO 7-1 (DIN 2999, BS 21)
 Seals: PTFE for ball, NBR 70 Shore for spindle

☑ Technical data

Maximum operating pressure: PN 4 bars (PN 25 for other, non-aggressive media)
 Maximum operating temperature: -20 °C to 60 °C
 Application: for gases of gas families 1, 2, 3 according to EN 437 (DVGW table G 260/I)

☑ Application

The ball valve is used as an "OPEN/CLOSED" type isolating valve with gas installations as per DVGW-TRGI, G 260/I. Areas of application include gas-fired heating systems, water heaters upstream of the consumer. The ball valve is used as a safety valve in gas installations.

☑ Installation

For the threaded connection commercially available sealing materials such as hemp fiber and sealing compound or Teflon tapes are used. The indicated maximum connection torque must not be exceeded when screwing in the pipe ends. We recommend to exclusively use the ball valve either in the fully opened or fully closed position, never in intermediate positions. The ball valve is maintenance-free, however, it is recommended to operate it 2 times a year.

Strainer for gas

Standard sheet for **2319**, issue 0209

☑ Dimensions

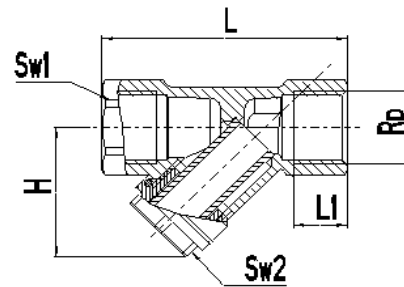

Order number	PN	DN	Rp	L	H	L1	Connection torque (Nm)	WAF 1	WAF 2	Weight kg
1 2319 01	5	15	1/2	68	37	15	75	25	22	0.170
1 2319 02	5	20	3/4	80	46	15	100	32	24	0.280
1 2319 03	5	25	1	90	55	19	125	41	25	0.510

☑ Version

Body: brass as per EN 12165
 Plugs: brass
 Sieve: chrome/nickel/steel, mesh width 0.05 mm
 Thread: female thread according to ISO 7-1 (DIN 2999, BS 21)
 Seals: NBR 70 Shore

☑ Technical data

Maximum operating pressure: PN 5
 Maximum operating temperature: -20 °C to 60 °C
 Application: for gases of gas families 1, 2, 3 according to EN 437 (DVGW table G 260/1)

☑ Application

The strainer is used with gas installations as per DVGW-TRGI, G 260/I. Areas of application include gas-fired heating systems, water heaters. The strainer protects sensitive gas devices such as gas meters or gas regulators from damage by particles larger than 0.05 mm contained in the gas stream.

☑ Installation

For the threaded connection commercially available sealing materials such as hemp fiber and sealing compound or Teflon tapes are used. The indicated maximum connection torque must not be exceeded when screwing in the pipe ends.

The ball valve is maintenance-free, however, it is recommended to operate it 2 times a year. The flow direction as indicated by the arrow on the body must be adhered to. It is recommended to install a HERZ ball valve upstream and downstream of the strainer for cleaning the sieve. The strainer must not be under pressure when opening the sieve plug. **EXPLOSION HAZARD!** After cleaning the sieve and closing the strainer, leak-tightness must be checked.

Angle ball valve for gas with aluminum or plastic T-handle

 Standard sheet for **2362-2372**, issue 0209

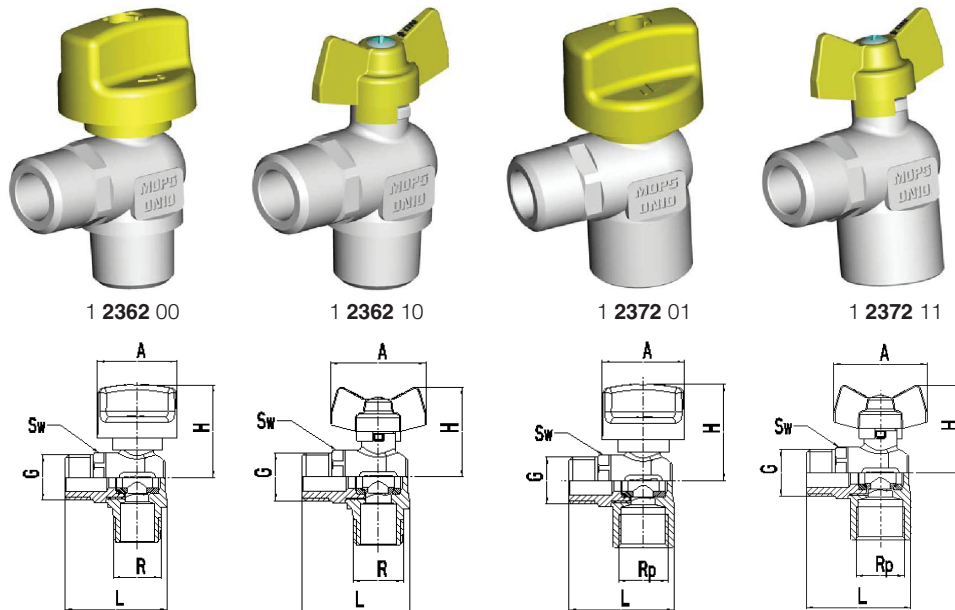
☑ Dimensions

Order number	Operating pressure	PN	DN	G R/Rp	L	H	A	Connection torque (Nm)	WAF	Weight kg
1 2362 00	5	1	10	1/2	44	43	35	75	21	0.145
1 2362 10						39	40			
1 2372 01	5	1	10	1/2	44	43	35	75	21	0.150
1 2372 11						39	60			

☑ Version

Body: brass as per EN 12165, nickel-plated
 Ball: forged brass, full opening, machine-polished and chrome-plated
 Spindle: brass
 Hand lever: 1 **2362 00** and 1 **2372 01** plastic handle, operation by pressing down and turning only
 1 **2362 10** and 1 **2372 11** aluminum die casting, operation by turning only
 Thread: female thread according to ISO 7-1 (DIN 2999, BS 21), male thread G ISO 228
 Seals: PTFE for ball, NBR 70 Shore for spindle

☑ Technical data

Maximum operating pressure: MOP 5 (EN 331) for gas, PN 16 for other, non-aggressive gases
 Maximum operating temperature: -20 °C to 60 °C for gas
 Application: for gases of gas families 1, 2, 3 according to EN 437 (DVGW table G 260/1), water, oil, air

☑ Application

The ball valve is used as an "OPEN/CLOSED" type isolating valve with gas installations as per DVGW-TRGI, G 260/I. Areas of application include gas-fired heating systems, water heaters upstream of the consumer. The ball valve is used as a safety valve in gas installations.

With versions 1 **2362 00** and 1 **2372 01** with plastic handle, the ball valve can only be opened by simultaneously pressing down and turning the handle in a counter-clockwise direction. The ball valve can be closed at any time by simply turning the hand lever.

☑ Installation

For the threaded connection commercially available sealing materials such as hemp fiber and sealing compound or Teflon tapes are used. The indicated maximum connection torque must not be exceeded when screwing in the pipe ends.

The ball valve is positioned upstream of the consumers as a means of fire protection.

We recommend to exclusively use the ball valve either in the fully opened or fully closed position, never in intermediate positions. The ball valve is maintenance-free, however, it is recommended to operate it 2 times a year.

All information contained in this brochure corresponds to the state of knowledge at the time of going to print and is intended for informational purposes only. We therefore reserve the right to make any changes subject to advancing technology. The images are symbolic representations only and can therefore visually deviate from the actual appearance of products. Any deviations in color are due to typography. Country-specific product variations are possible. We reserve the right to change specifications and functions without notice. Please contact your nearest HERZ subsidiary if you have any questions.



Österreichische Vereinigung für das Gas- und Wasserfach
 A-1015 Wien, Schuberting 14, Postfach 26
 Telefon: +43 / 1 / 513 15 88-0* / Telefax: +43 / 1 / 513 15 88-25
 E-Mail: office@ovgw.at / Internet: www.ovgw.at



Akkreditiert durch das Bundesministerium
 für Wirtschaft, Familie und Jugend



ÖVGW-Zertifikat

über die Verleihung des Rechtes
 zur Führung der ÖVGW-Qualitätsmarke Gas

Registrierungsnummer

G 2.951

Produkt

Gas-Kugelhahn (Durchgangsform)

Gültigkeitsdauer

bis Ende November 2013

MOP 5 bar, Kategorie II_{2H3B/P}

Inhaber ♦ Vertrieb in Österreich

Herz Armaturen GmbH
 Richard Strauss Straße 22
 A-1230 Wien

Type: 1 2300 ..
 in den Dimensionen
 DN 8, 10, 15, 20, 25, 32, 40, 50

Weitere Angaben siehe Seite 2

Hersteller

Herz d.d / SLO

Prüfungsart

Erstprüfung

Prüfbericht

TGM – VA HL 7849 vom 24. November 2010

Prüfrichtlinien

- PG 500 (Ausgabe Juli 2009)
- PG 337 (Ausgabe April 2006)
 (ÖNORM M 7437: 2000-01)

ZVR 818158001

Die Verleihung erfolgt unter Zugrundelegung der Allgemeinen Geschäftsbedingungen GW 30 ÖVGW-Qualitätsmarke
 Produkte Gas & Wasser „Voraussetzungen für die Zuerkennung der ÖVGW-Qualitätsmarke für Produkte der Gas- und
 Wasserversorgung.“

2

Wien, am 29. November 2010



Dipl.-Ing (FH) Alexander Schwanzer
 Leiter der ÖVGW-Zertifizierungsstelle

INSTITUT
MIHAILO
PUPIN
BEOGRAD

IMP MEHATRONIKA D.O.O
AKREDITOVANA LABORATORIJA ZA GASNU TEHNIKU NA012
 Volgina 15, 11000 BEOGRAD, Jugoslavija Tel:011/772-151; Fax:011/773-003; POB:15

UVERENJE

O IZVRŠENOM TIPSKOM ISPITIVANJU

Metalnih ručnih zapornih kuglastih slavina za unutrašnje gasne instalacije PN 4
K 77 (KV 3020 do KV 3070) i K 77 F x M (KV 302T do KV 3071)

Broj 9917

Prema standardima: JUS M.C5.452, JUS M.C5.450
 Proizvođač: KOVINA Grmaška cesta 3, 1275 Šmartno pri Litiji, Slovenija
 Naručilac ispitivanja: CIM Gas Subotica, Kizur Ištvana 36
 Tehnički podaci: DN15, DN20, DN25, DN32, DN40, DN50. Radna temperatura -10°C do +110°C. Nazivni pritisak PN4. Kučište od presovanog mesinga, Cu Zn39 Pb3, kugla presovana od mesinga i hromirana, zaptivke PTFE.
 Priložena dokumentacija: Prospekt; sklopni crtež; priložena strana atestna dokumentacija.

Ispitivanje vršeno od 6.09.1999. do 17.09.1999.

Ispitivanjem tipa proizvoda utvrđeno je da ispitivani uređaj ispunjava zahteve propisane navedenim standardima.

Podaci o izvršenom ispitivanju sadržani su u Izveštaju br. 9917 koji je sastavni deo ovog Uverenja

U Beogradu 17.09.1999.

TEHNIČKI RUKOVODILAC
LABORATORIJE NA 012
Miroslava Buljaka dipl. ing.

INSTITUT
MIHAILO
PUPIN
BEOGRAD

IMP MEHATRONIKA D.O.O
AKREDITOVANA LABORATORIJA ZA GASNU TEHNIKU NA012
 Volgina 15, 11000 BEOGRAD, Jugoslavija Tel:011/772-151; Fax:011/773-003; POB:15

UVERENJE

O IZVRŠENOM TIPSKOM ISPITIVANJU

Metalnih ručnih zapornih kuglastih slavina za unutrašnje gasne instalacije PN 4
K 95 - (KV 300 do KV 307)

Broj 9915

Prema standardima: JUS M.C5.452, JUS M.C5.450
 Proizvođač: KOVINA Grmaška cesta 3, 1275 Šmartno pri Litiji, Slovenija
 Naručilac ispitivanja: CIM Gas - Subotica, Kizur Ištvana 36
 Tehnički podaci: DN15, DN20, DN25, DN32, DN40, DN50. Radna temperatura -10°C do +110°C. Nazivni pritisak PN4. Kučište od presovanog mesinga, Cu Zn39 Pb3, kugla presovana od mesinga i hromirana, zaptivke PTFE.
 Priložena dokumentacija: Prospekt; sklopni crtež; priložena strana atestna dokumentacija.

Ispitivanje vršeno od 6.09.1999. do 17.09.1999.

Ispitivanjem tipa proizvoda utvrđeno je da ispitivani uređaj ispunjava zahteve propisane navedenim standardima.

Podaci o izvršenom ispitivanju sadržani su u Izveštaju br. 9915 koji je sastavni deo ovog Uverenja

U Beogradu 17.09.1999.

TEHNIČKI RUKOVODILAC
LABORATORIJE NA 012
Miroslava Buljaka dipl. ing.

Strojirenský zkušební ústav, s.p., autorizovaná osoba 202, Hudcova 56b, 621 00 Brno
Česká republika
Rozhodnutí o autorizaci č. 31/2002 ze dne 2002-09-18

CERTIFIKÁT VÝROBKU

číslo: B - 30 - 00550 - 03

vydaný dovezci, firmě

AZ - Pokorny, s.r.o.
Cermákovice 20, 671 73 Tulešice
identifikační číslo: 25300849

na výrobky

Kulové kohouty na plyn
typy:
K950, K960, K980
bližší specifikace výrobků je uvedena na 2. straně

výrobce
(jen pro dovezce)

KOVINA
Kovinskó predelovno podjetje d.d.
Šmartno pri Litiji, Slovensko

Výše uvedená autorizovaná osoba tímto osvědčuje, že u vzorků předmetných výrobků zjistila shodu jejich vlastností se základními požadavky nařízení vlády č. 163/2002 Sb. a že dovozcem je zajištěna řádná kontrola výrobků, tak jak požaduje § 5 uvedeného nařízení vlády. Při posuzování shody použila autorizovaná osoba následující normy:

ČSN EN 331:1999, ČSN EN 1775:1999.

Nedílnou součástí tohoto certifikátu je závěrečný protokol č. 30-3192/1 ze dne 2003-06-25, vystavený Strojirenským zkušebním ústavem.

Pravidla pro nakládání s certifikátem jsou uvedena na 3. straně.

Brno 2003-06-25

AUTORIZOVANÁ OSOBA
STROJIRENSKÝ ZKŠEBNÍ ÚSTAV
ÚNMZ

Ing. Josef Bartl
ředitel

B-30-00550-03 strana 1 (3)

Splnění základních požadavků nařízení vlády č. 163/2002 Sb. bylo odvozeno ze splnění požadavků a technickým předpisů, uvedených na předcházející straně. Novelizace některého z normativních dokumentů, zejména novelizace harmonizovaných norem nebo určených norem nebo vydání nových harmonizovaných norem může změnit skutečnosti, za kterých byl certifikát vystaven. V takovém případě je třeba prozkoumat použitelnost certifikátu pro účely vydání prohlášení o shodě výrobků uvedených na trh.

Certifikace byla provedena podle ustanovení § 10 zákona č. 22/1997 Sb., o technických požadavcích na výrobky a o změně a doplnění některých zákonů, ve znění zákonů č. 71/2000 Sb., č. 102/2001 Sb. a č. 205/2002 Sb.

Specifikace výrobků:

Kulové kohouty splňují požadavek ČSN EN 1775:1999 čl. 4.2 - Ochrana proti požáru (odolnost proti vysoké teplotě do 650 °C po dobu 30 minut) při provozním tlaků 100 kPa.

Typ:	K950	K960	K980
Tlaková třída:	MOP 5 (0,5 MPa)		
Rozsah pracovních tlaků:	0,001 MPa ÷ 0,5 MPa		
Provozní tlak:	1 bar (0,1 MPa) pro odolnost proti vysoké teplotě do 650 °C po dobu 30 minut - označení výrobce GT 1		
Provozní médium:	plyny 1., 2. nebo 3. třídy podle ČSN EN 437:1996		
Jmenovitá světlost DN:	8, 10, 15, 20, 25, 32, 40, 50		
Teplotní třída:	MOT - 20 °C		
Rozsah teplot:	-20 °C ÷ 60 °C		
Materiály			
těleso:	mosaz CuZn40Pb2, CW617N, EN 12165		
těleso-připojka:	mosaz CuZn40Pb2, CW617N, EN 12165		
koule:	mosaz CuZn39Pb3, CW614N, EN 12164, tvrdochrom		
vřetenno:	mosaz CuZn39Pb3, CW614N, EN 12164		
těsnění sedla:	2x o-kroužek - elastomer FX 362		
těsnění vřetenno:	2x o-kroužek - pryž NB 701		
ovladač:	ocel RS137-2 potažená žlutým plastovým obalem		
Připojky:	závit ¼, ½, ¾, 1, 1¼, 1½, 2 podle ČSN ISO 7-1:1996		závit ¼, ½, ¾, 1, 1¼, 1½, 2 vnitřní Rp podle ČSN ISO 7-1:1996
1.	vnitřní Rp	vnitřní Rp	vnitřní Rp podle ČSN ISO 7-1:1996
2.	vnitřní Rp	vnější R	vnější G podle ČSN ISO 228-1:1996
Ovládní:	páka		
Konstrukce:	těleso dvoudílné, spoj těsněn, koule a vřetenno složeny zevnitř, vřetenno těsněno dvěma o-kroužky		

B-30-00550-03 strana 2 (3)

42

Notes

Notes

HERZ Valves UK
Progress House * Moorfield Point *
Moorfield Road * Slyfield Industrial Estate * Guildford *
Surrey * GU1 1RU
Telephone: 01483 502211, Fax: 01483 502025
e-mail: sales@herzvalves.com

HERZ Armaturen GmbH
Richard-Strauss-Straße 22, A-1230 Wien
Tel.: +43/(0)1/616 26 31-0, Fax: +43/(0)1/616 26 31-27
E-Mail: office@herz.eu

www.herz.eu

