

Installation manual

Monoblock Heat Pump Type HPX



EN - v2.1 / 1-2026
ORIGINAL INSTRUCTIONS

Contents

1. Introduction	3	7. Commissioning	27
1.1. Symbols used in this manual	3	7.1. Checklist	27
1.2. Warranty	3	7.2. Test run	28
1.3. Reporting malfunctions	3	7.3. Control panel	28
1.4. Disclaimer	3		
2. Safety instructions	4	8. Daily usage and maintenance	36
		8.1. General maintenance	36
		8.2. Important for usage in the winter	36
		8.3. Regaining refrigerant	36
		8.4. Putting out of operation	37
3. The functioning principle of the Heat Pump	11	9. Malfunctions	38
		9.1. Malfunction index	38
		9.2. Error code list	38
		9.3. Flow chart troubleshooting	41
		9.4. Diagnosis of the PCB	44
4. Technical specifications	12	10. Electrical wiring diagram	45
4.1. Technical specifications	12	10.1. Control board HPX06A / HPX12A / HPX16A	45
4.2. Dimensions	13		
4.3. Temperature limits	14	11. Spare parts and accessories	54
4.4. Maximum and minimum water pressure	15	11.1. Table of spare parts HPX	54
		11.2. Table of accessories HPX	54
5. Installation	15	12. Disposal and recycling	55
5.1. General instructions	15		
5.2. Setting up the Heat Pump	15	13. Declaration of conformity	55
5.3. Closing water side	18		
5.4. Electrical connection	21		
6. Activities related to the refrigerant circuit	25		
6.1. General	25		
6.2. Filling and draining the refrigerant	25		
6.3. Leakage detection	26		

1. Introduction

This manual is intended for the installer of electrical and mechanical appliances.

This document contains instructions to use and maintain the Heat Pump. It is imperative to read the instructions in this document with care, to install the appliances functionally and safely.

It is paramount that this document is read thoroughly before installing the heat pump. Keep this document saved for quick reference if needed.

1.1. Symbols used in this manual

DANGER! Indicates a dangerous situation that may lead to death or severe injury.

WARNING! Indicates a possibly dangerous situation that may lead to death, severe injury, or product damage.

CAUTION! Indicates a possibly dangerous situation that may lead to injury or product damage.

PAY ATTENTION! Provides important information which is not directly related to safety issues.

1.2. Warranty

PAY ATTENTION! Using, installing, or maintaining this heat pump in a different manner than this manual indicates, may lead to product damages which cause the warranty to become void.

CAUTION! When the safety instructions described in this manual are disregarded, damage to the heat pump or the installation may incur and the warranty will become void.

1.3. Reporting malfunctions

If the product is defective and cannot be used, please contact your installer and provide the following information:

- Information on the rating plate of the product (model, Heating capacity, product number, date of production).
- Nature of the malfunction (specify the situations before and after the occurrence of the error).

1.4. Disclaimer

All rights reserved. No part of this installation manual may be reproduced or published by means of print, photocopy, microfilm, or in any other way, without the prior written permission of Winterwarm Heating Solutions B.V.. This also applies to any accompanying drawings, diagrams, and appendices. The information in this manual is based on the most recently available data. Winterwarm Heating Solutions B.V. reserves the right to modify or improve parts at any time without prior notice to the customer. The contents of this installation manual may be changed without prior notice. This manual has been compiled with care. Nevertheless, Winterwarm Heating Solutions B.V. accepts no liability for any errors or their consequences.

2. Safety instructions

2.1. Installation by qualified personnel

WARNING! This appliance has to be installed, operated, and maintained by qualified personnel who have followed the specific training required. It is of the utmost importance that all safety precautions mentioned on the labels, the user manual, and other documentation are followed with due diligence when operating this appliance.

WARNING! This appliance is not intended for usage by individuals with limited physical, sensory, or mental capacities (this includes children). Neither should the appliance be used when the required knowledge and experience are lacking, unless the proper instructions and supervision are provided to do so by an authorized safety professional. Children should be supervised to prevent them from playing with the appliance.

2.2. Service and inspection

WARNING! This product is subjected to strict inspections and operational tests prior to leaving the factory. It is very important to refrain from disassembling the product by yourself, to prevent possible damage being incurred by incorrect disassembly and inspection. Instead, consult our designated dealer or local service centre for professional support.

PAY ATTENTION! After receiving the unit, be sure to check its appearance and the supplied accessories. Compare these to your order.

WARNING! The design and installation tasks of this unit must be executed by authorized personnel, in agreement with the applicable laws and regulations and these instructions.

WARNING! The unit cannot be enabled directly after the installation unless it has been confirmed that no issues have arisen during the checking of the appliance.

CAUTION! Make sure that the unit is cleaned and maintained regularly, to ensure longevity and reliability of the appliance.

WARNING! If the power cord is damaged, it must be replaced by the manufacturer, an authorized service agent, or a qualified person to avoid risks.

WARNING! The appliance has to be installed in accordance with the national wiring requirements.

WARNING! This product is a kind of comfort-air conditioning and cannot be installed at places where corrosive, explosive, and combustible elements or smog are present. This could lead to operational disturbances, shortened lifespans, danger, or severe injury. Special air conditions are required at these locations.

WARNING!

If an abnormal situation occurs, such as a burning smell, immediately switch off the power supply and contact your installer.



If the defect persists, product damage and electrical shocks or fire may occur.

Do not use the appliance with wet hands.



This may lead to electrical shocks.

Check prior to the installation whether the power supply is in line with the rating plate and whether the connection cable or the wall outlet is suitable for the power of the device.



It is important to use a dedicated circuit for the power supply to prevent fire.

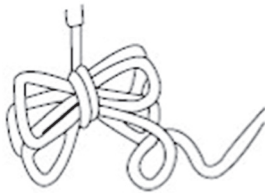

Do not use a multi-functional plug or extension cord for the connection

When the unit is not in use for a long period of time, unplug it and drain the water system.

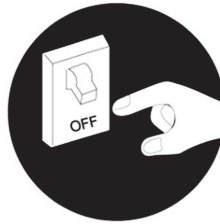

In this way, it is prevented that accumulated dust in the winter leads to overheating, fire hazards, or freezing of the water tank or heat exchanger.

Only use undamaged and specified electrical connection wires.



Usage of damaged or non-specified wires may lead to overheating or fire hazards.

Shut off the power supply before cleaning the device.

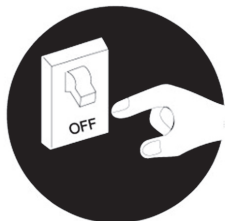

Otherwise, electrical shocks and damages may occur.

The power supply has to be a dedicated circuit with RCD (Residual Current Device) and needs to have sufficient capacity.

The user cannot modify the connections of the power cord, without being given permission in advance. Electrical wiring has to be executed by professionals. Ensure proper grounding and do not alter the grounding modes of the appliance.

WARNING!

Grounding: The unit needs to be grounded reliably! The Ground wire needs to connect with the grounding of the installation.

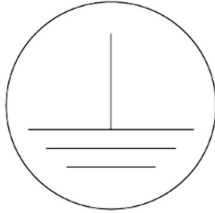

Ask qualified personnel for installation. Furthermore, the grounding wire should not be connected to gas pipes, water pipes, drainage pipes, or other incorrect locations that are not recognized by professionals.

Never put any odd objects in the outdoor unit to prevent damage. Also, refrain from putting your hands in the air outlet of the outdoor unit.

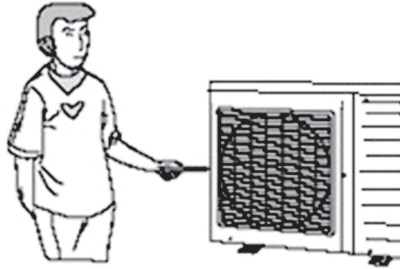

Do not try to repair or replace the appliance by yourself.



Incorrect reparation may lead to electrical shocks or fire hazards. Please contact your installer for reparations.

Do not step on, or place anything on the appliance.



Otherwise falling danger of objects or people may occur.

Never block the air intake and outlet of the device.

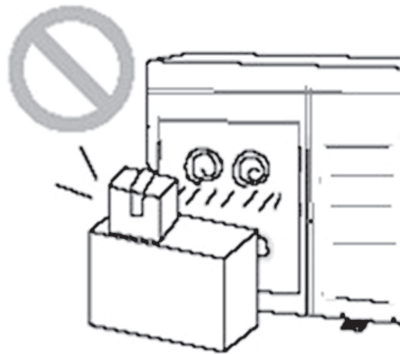

This could reduce efficiency or lead to malfunctions.

Keep compressed air cylinders, gas bottles, and such at at least 1 meter distance of the appliance.

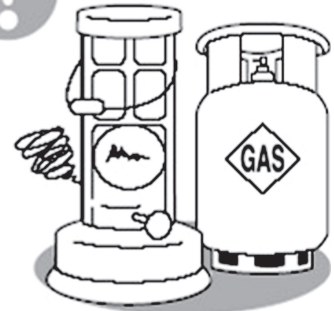

This may cause fire hazards or explosions.

WARNING!

Make sure that the installation stand is sufficiently sturdy.

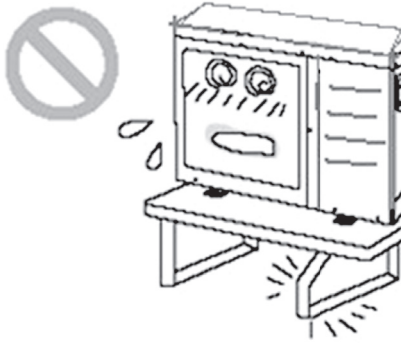

If it is damaged this may lead to the unit becoming damaged and people getting injured.

The unit has to be installed at a location with enough ventilation for performance efficiencies.

Never turn the unit on if there is no water in the system.

WARNING! Do not use any means to accelerate the defrosting process or for cleaning, other than those that are recommended by the manufacturer. If repairs are required, please contact your nearest authorized service center. Repairs executed by unqualified personnel can be dangerous. The appliance needs to be stored in a place without continuously operating ignition sources (such as open flames, a functioning gas appliance, or an electrical heater). Do not puncture or burn.

WARNING! The appliance needs to be installed outside and stored in a room with a square footage larger than X m² (consult table "a" in the section "safe usage of combustible refrigerants" for the value X)

WARNING! The appliance is filled with the flammable gas R32. It is paramount that the instructions of the manufacturer are followed at all times when performing reparations. Take into account that refrigerants have no smell. Read the manual of the specialist.

WARNING! If a stationary appliance is not provided with a power cable and a plug, or other means to decouple the mains with a full interruption of the contacts under the circumstances

of overvoltage category III, means of decoupling have to be included in the fixed connection in accordance with the wiring regulations.



WARNING! This appliance can be used by children from the ages of 8 and above and individuals with reduced physical, sensory, or mental capacities, or individuals with a lack of experience and knowledge, provided that they are supervised or have received instructions about safely using the appliance and understanding the dangers. Children are not allowed to play with the appliance. Cleaning and user maintenance cannot be executed by children without supervision.

WARNING! The appliance has to be stored in a well-ventilated area, with a size corresponding to the indicated operating space.

WARNING! The appliance has to be stored in a place without continuously functioning open flames (for example a functioning gas appliance) and sources of ignition (for example a functioning electric heater).

CAUTION! The appliance needs to be stored properly to prevent mechanical damage

PAY ATTENTION!

	The appliance is filled with the flammable gas R32.
	Read the user manual before using the appliance.

WARNING! There is a special refrigerant in the appliance to guarantee the functionality of the heat pump. This refrigerant is the fluoride R32, which is specially treated. The refrigerant is combustible and odorless. It could lead to explosions under certain circumstances. However, the flammability of this refrigerant is very low and will only be ignited by fire.

In comparison to other refrigerants, the R32 is environmentally friendly and it has no damaging effects on the ozone layer. Besides that, this appliance has a lesser impact on the greenhouse effect than comparable devices. The R32 has excellent thermodynamical properties also, resulting in high energy efficiency and requiring less refrigerant.

CAUTION! Before installation, it is important to check if the power used corresponds to the specifications indicated on the nameplate to ensure the safety of the power supply. The unit must be connected to the electricity network using a full disconnecting device under the overload category III.

WARNING! Before use, it is advisable to check if the wiring and pipes are

connected to prevent water leakage, electric shocks, and fire hazards.

DANGER! Do not operate the unit with wet hands and do not allow children to operate the appliance. The “On/Off” button referred to in the manual is the button on the control panel. “Power Off” means that the power supply to the unit is interrupted.

WARNING! Do not expose the unit directly to corrosive environments with water or humidity. Do not use the unit without water in the water reservoir. The air outlet/inlet of the unit should not be blocked by other units.

CAUTION! When the unit is not in use, drain the water in the unit and pipes to prevent freezing and cracking of the water reservoir, pipes, and water pump.

CAUTION! To protect the buttons of the control panel, refrain from using sharp objects to press the buttons. Never use gasoline, thinner or chemical cloths to prevent fading and failure for components. Instead use a neutral clean agent, and clean the display and connection components carefully to prevent fading.

CAUTION! The power cable has to be separated from the communication cables.

WARNING! Every individual who is involved in working on or opening the refrigeration circuit needs to have a valid certificate from an authorized assessment authority.

Maximum and minimum water operating temperatures		
Item	Minimum water operating temperatures	Maximum water operating temperatures
Cooling	5 °C	25 °C
Heating	20 °C	65 °C
Water heating	40 °C	80 °C
Maximum and minimum water operating pressures		
Item	Minimum water operating pressure	Maximum water operating pressure
Cooling	0.5 bar	2.5 bar
Heating		
Water heating		

Maximum and minimum water operating temperatures		
Item	Minimum water operating temperatures	Maximum water operating temperatures
Maximum and minimum entering water pressures		
Item	Minimum water entering pressure	Maximum water entering pressure
Cooling	0.5 bar	2.5 bar
Heating		
Water heating		
Range of external static pressures where the appliance is tested. (Only with heat pumps and appliances with extra heating).		
If there are any questions, please contact your distributor.		

WARNING! If the supply cord is damaged, it must be replaced by the manufacturer, its service agent or similarly qualified persons in order to avoid a hazard.

PAY ATTENTION! Installation guidelines:

DANGER! If there is work conducted involving the usage of heat when working with refrigeration equipment or other components, suitable fire extinguishing equipment needs to be within reach. Place a dry powder- or CO₂ fire extinguisher when filling.

CAUTION! When replacing electrical components, they must be suitable for the intended purpose and meet the correct specifications. Maintenance and service guidelines provided by the manufacturer must be followed at all times. In case of doubt, you can contact the manufacturer's technical support for assistance.

The following checks should be carried out for installations with flammable refrigerants: The quantity of refrigerant corresponds to the size of the space in which the components with refrigerant are installed.

WARNING! The ventilation machines and exhausts are functioning properly and are not obstructed. If an indirect cooling circuit is used, the secondary circuit should be checked for the presence of refrigerant.

CAUTION! The markings on the device remain visible and readable. Illegible markings and signs should be corrected.

Refrigerant lines or components are installed in a position where they are not to be exposed to substances that could corrode the refrigerant-containing components, unless the components are made of materials inherently resistant to corrosion or are appropriately protected against corrosion.

Repairs and maintenance of electrical components include initial safety checks and inspection procedures of the components. If there is a defect that could jeopardize safety, no electrical power should be connected to the circuit until the defect is resolved. If the defect cannot be fixed immediately. An adequate temporary solution should be used, this should be reported to the owner of the device, so all parties involved are aware.

Initial safety checks encompass: discharging the capacitors in a safe manner to prevent the risk of sparks; ensure that there are no voltage-carrying electrical components and wiring out in the open. When filling, recovering, or rinsing the system; make sure that there is continuity in the grounding.

DANGER! During repairs to the sealed components, the device should not be electrically connected. If it is necessary to supply the appliance with electricity during repairs, a special permanently functioning kind of leakage detection

needs to be applied to the most critical point on the appliance to alert for potentially hazardous situations.

CAUTION! Special attention should be given to the following: Exercise caution when working on electrical components, so the housing does not alter in a way that compromises the degree of protection/waterproofing. This includes damage to cables, an excessive amount of connections, connections that are not made according to the original specifications, damage to seals, improper mounting of cable glands, etc.

WARNING! Make sure that the device is securely mounted.

DANGER! Make sure that the seals or sealing materials are not degraded to the extent that they are unsuitable to protect against the penetration of flammable vapors. Replaced components have to be in accordance with the specifications of the manufacturer.

WARNING! The use of silicone sealant can hinder the effectiveness of certain types of leakage detection equipment. Intrinsically safe components do not need to be shut off prior to working on them.

CAUTION! Make sure that the voltage and electricity limits of the appliance are not exceeded when adding inductive or capacitive loading to the circuit.

WARNING! Only intrinsically safe components can be used when inflammable objects are in the presence of inflammable vapors. Moreover, the test device needs to be classified properly.

DANGER! Only use specified replacement components that are produced by the manufacturer. The usage of unoriginal parts may lead to the leakage of refrigerants in the atmosphere and may lead to fire hazards.

CAUTION! Ensure that the wiring is not exposed to erosion, corrosion, excessive pressure, vibrations, sharp angles, or

other negative environmental influences. When checking the safety effects caused by aging or consistent vibrations of sources such as compressors and fans need to be taken into account.

DANGER! Under no circumstances can sources of ignition be used to look for leaking refrigerants. A naked flame (or other detector that uses an open flame) cannot be used.

DANGER! Equipment has to be labeled with the mention that refrigerant is removed and the device is out of service. The label needs to be provided with a date and signature. Make sure that there are labels on the devices that mention that the appliance contains flammable refrigerants.

3. The functioning principle of the Heat Pump

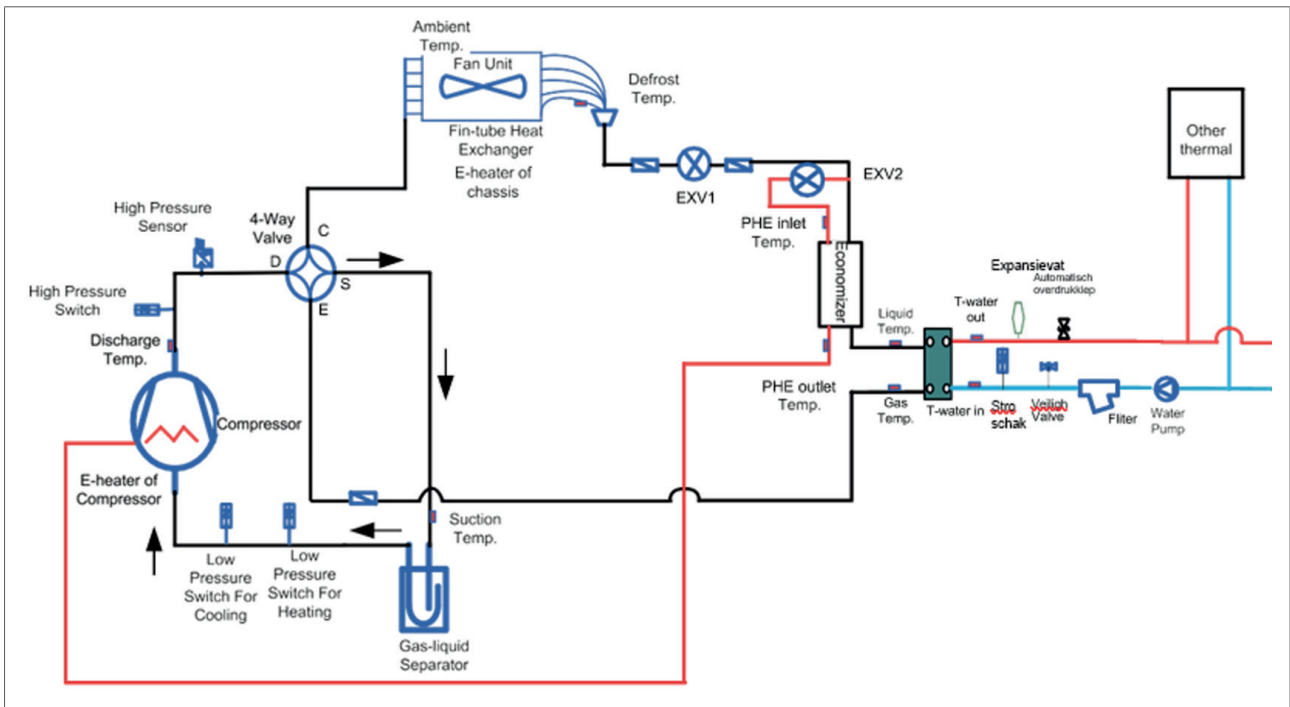

Figure 1 - Functioning principle of the Heat Pump

Functions:

1. Cooling;
2. Heating;
3. Emergency operation;
4. Forced operating mode;
5. Venting the water system;

1. **Cooling:** In the cooling mode the refrigerant is condensed in the outdoor unit and evaporated in the heat exchanger. The heat exchange with water in the heat exchanger leads the temperature to decrease and releases heat, while the refrigerant absorbs and condenses the heat. The settings for the water temperature can be operated by the room thermostat. By operating the valve, cold water will be connected to the system of issuing, so the water temperature will decrease to the desired range.
2. **Heating:** The refrigerant evaporates in the heating mode and will be condensed in the heating exchanger of the outdoor unit. As a result of the heat exchange with water in the heat exchanger, the water will absorb heat and increase in temperature, while the refrigerant emits heat and

condenses. The temperature is regulated by the room thermostat. The valve arranges a connection between the high-temperature water in the system and the indoor heat exchange with the fan, and exchanges heat with the air indoors, so the core temperature will rise to the required range.

3. **Emergency operation:** This mode is only available for heating and warm water heating. When the outside unit stops functioning for any reason, the added emergency mode will be activated. In heating mode, after entering emergency mode heating can only be realized through the optional e-heater of the outdoor unit. When the set outlet temperature or indoor temperature is reached, the e-heater of the outdoor heater stops working.
4. **Forced operating mode:** This mode is only used for regaining refrigerant and detecting malfunctions of the device.
5. **Venting the water system:** This function is meant to fill up water and remove air from the water system, so the appliance can function at a stable water pressure level.

4. Technical specifications

4.1. Technical specifications

Technical specification	Unit	HPX06A	HPX12A	HPX16A	HPX30A
Heating capacity *	kW	6.0	12.0	15.7	30.0
Absorbed electrical power	kW	1.11	2.49	3.57	6.90
COP	-	5.41	4.82	4.40	4.35
SCOP	-	5.041	4.584	4.556	4.667
Energy classroom heating ** (811/2013/EU)	-	A+++	A+++	A+++	A+++
Seasonal Energy Efficiency of Space Heating $\eta_{s,h}$	%	198.7	180.3	179.2	183.0
Refrigerant	-	R32	R32	R32	R32
Refrigerant contents	kg	0.95	2.2	2.2	5.0
Net weight	kg	90	144	144	261
Dimensions (W × D × H)	mm	1150 × 372 × 733	1206 × 445 × 878	1206 × 445 × 878	1750 × 531 × 1255
Water connection	G"	1	1	1	1.5
Voltage outdoor unit (Hz)	V	230	3×400	3×400	3×400
Electrical current outdoor unit	A	11.0	11.5	12.5	22.9
Sound level, heating	dB(A)	58	54	56	58
Sound level, cooling	dB(A)	56	55	59	58

Technical specification	Unit	HPX06A	HPX12A	HPX16A	HPX30A
Sound level, defrosting	dB(A)	58	68	68	68
Protection class	-	IPX4	IPX4	IPX4	IPX4
Outdoor temperature range heating modes	°C	-25 / 35	-25 / 35	-25 / 35	-25 / 35
Contents internal expansion vessel	L	2	3	3	10
Maximum height 1" without extra expansion vessel	m	70	100	100	180
Maximum height 1.5" without extra expansion vessel	m	-	-	-	180
Water flow	m ³ /hr	1.1	2.1	2.8	5.2
Waterside designed pressure	Bar	1.5	1.5	1.5	1.5
Maximum discharge head	m	8	9	9	9
Modulating compressor	-	Yes	Yes	Yes	Yes
Modulating energy-efficient water pump	-	Yes	Yes	Yes	Yes
Venting + overflow included	-	Yes	Yes	Yes	Yes
Water circulation filter supplied	-	Yes	Yes	Yes	Yes

* Heating capacities and power input are based on the following circumstances: Temperature of the water 30°C/35°C. Outside temperature of the air 7°C DryBulb/6°C WetBulb.

** Cooling capacities and power input are based on the following circumstances: Water temperature 23°/18°C. Outside temperature of the air 35°C DryBulb/24°C WetBulb.

4.2. Dimensions

The dimensions of this heat pump can be found in figure 2.

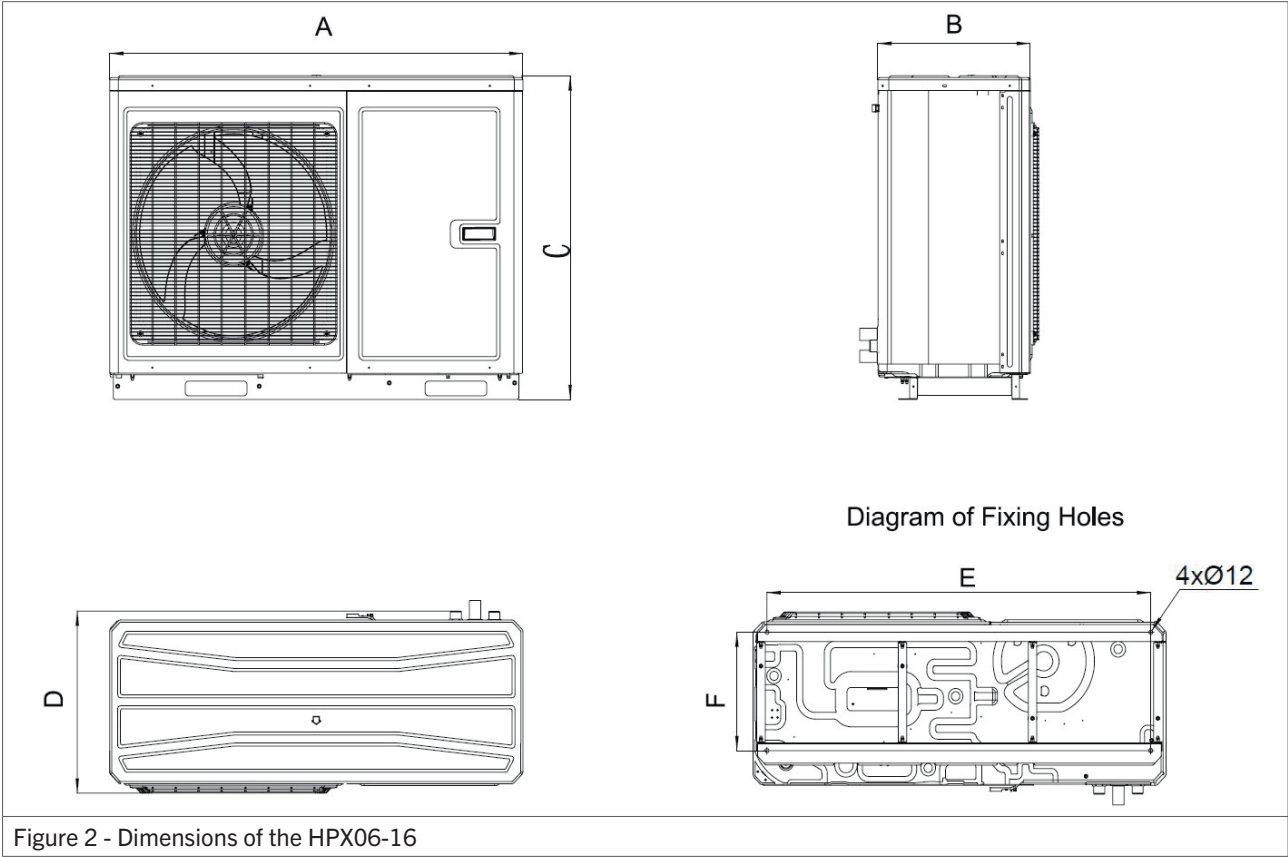

Figure 2 - Dimensions of the HPX06-16

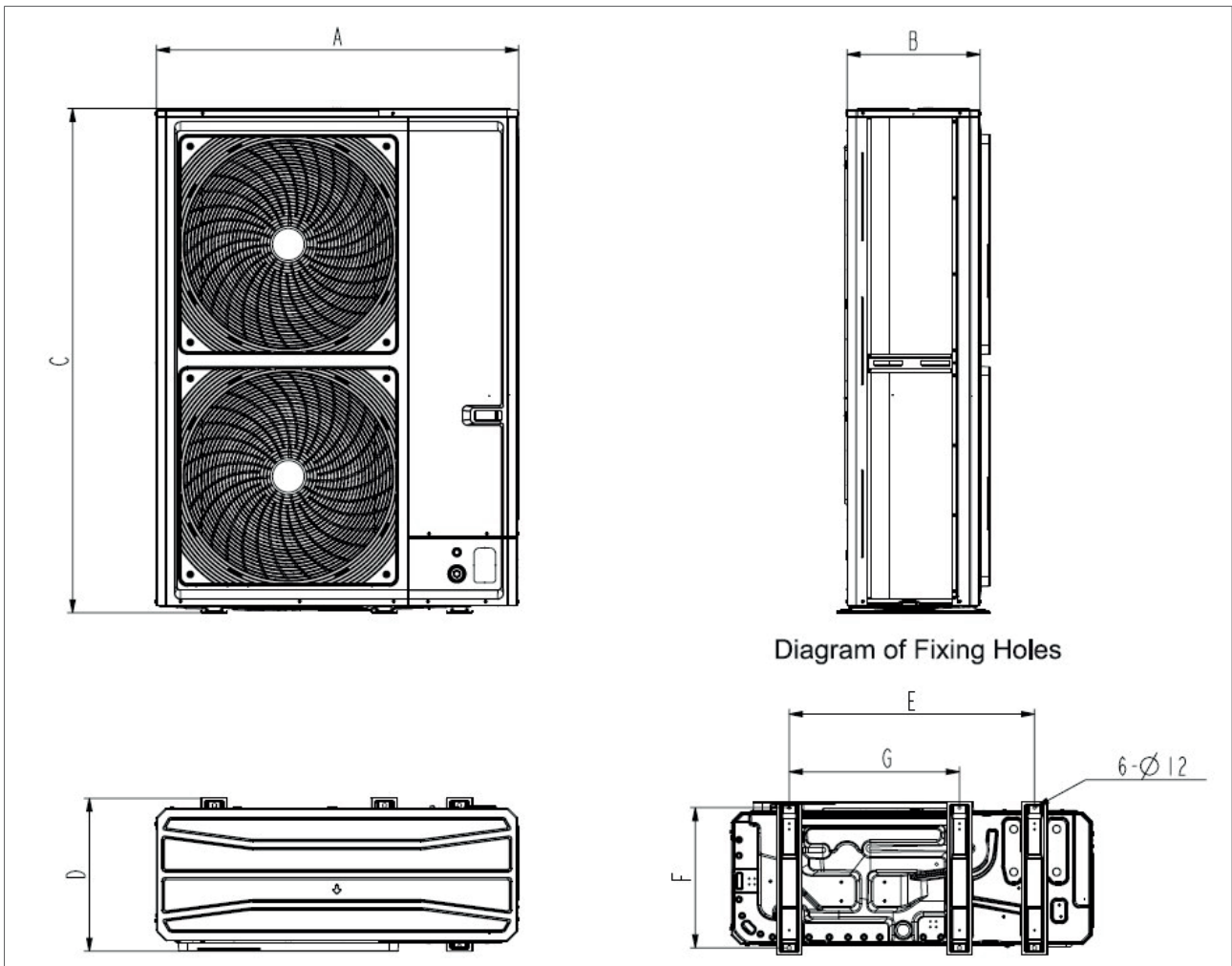

Figure 3 - Dimensions of the HPX30

	A	B	C	D	E	F	G
HPX06A	1150	365	750	415	1063	302	-
HPX12A	1206	445	880	490	1120	322	-
HPX16A	1206	445	880	490	1120	322	-
HPX30A	1255	461	1750	531	850	486	590

4.3. Temperature limits

The device has limitations in regard to functioning well in different outdoor temperatures.

Mode	Outdoor Temperature (°C)	Water Temperature (°C)
Heating	-25 - 35	20 - 65
Cooling	-15 - 48	5 - 25

The environmental and water temperature both influence the functioning of the device.

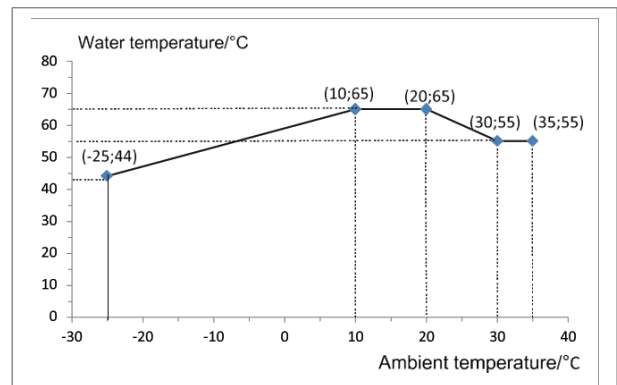

Figure 4 - The influence of environmental temperatures and the maximum water temperature

4.4. Maximum and minimum water pressure

Mode	Minimum water pressure	Maximum water pressure
Heating	0.5 bar	2.5 bar
Cooling	0.5 bar	2.5 bar

Model	Internal expansion vessel capacity	Inlet pressure
HPX06A	2 litres	1.5 bar
HPX12A - HPX16A	3 litres	1.5 bar
HPX30A	10 litres	1 bar



Figure 5 - Location of the internal expansion vessel

5. Installation

5.1. General instructions

- **PAY ATTENTION!** The installation of the unit has to be in accordance with national and local safety precautions.
- **PAY ATTENTION!** The quality of the installation has a direct influence on the performance of the heat pump. The installation has to be conducted by professionals who are familiar with heat pump installations.
- **PAY ATTENTION!** Do not connect the unit to a power source until all installation activities are concluded.
- **PAY ATTENTION!** It is generally NOT required to modify the refrigerant circuit during the installation. There is no F-gasses certification requirement for installing the heat pump.
- **PAY ATTENTION!** Actions regarding the refrigerant circuit can only be conducted by certified individuals.

5.2. Setting up the Heat Pump

CAUTION! Always keep a minimum distance of 2000 mm between the flue of an air heater and a heat pump (see figure 6). The fumes of the air heater can be sucked in by the heat pump and damage the heat exchanger.

- The heat pump needs to be installed on a sturdy and solid foundation. The free space between the lower part and bottom of the heat exchanger has to be at least 300 mm.
- The airflow at the entry and outlet cannot be blocked.
- Install the heat pump at a well-ventilated location, so the machine can absorb and drain a sufficient amount of air.
- Do not place the device under a window or between two buildings to avoid nuisance of normal operating sounds.
- Do not install the device in a location where open

flames, flammable or combustible elements are present. Also avoid locations that have a lot of dust, salty mist, and polluted air.

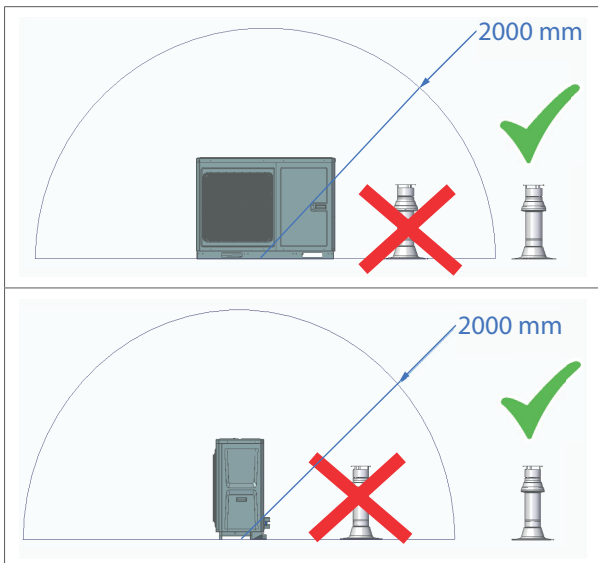

Figure 6 - Minimum distance between the flue of an air heater and a heat pump

5.2.1. Distances to hindering airflow

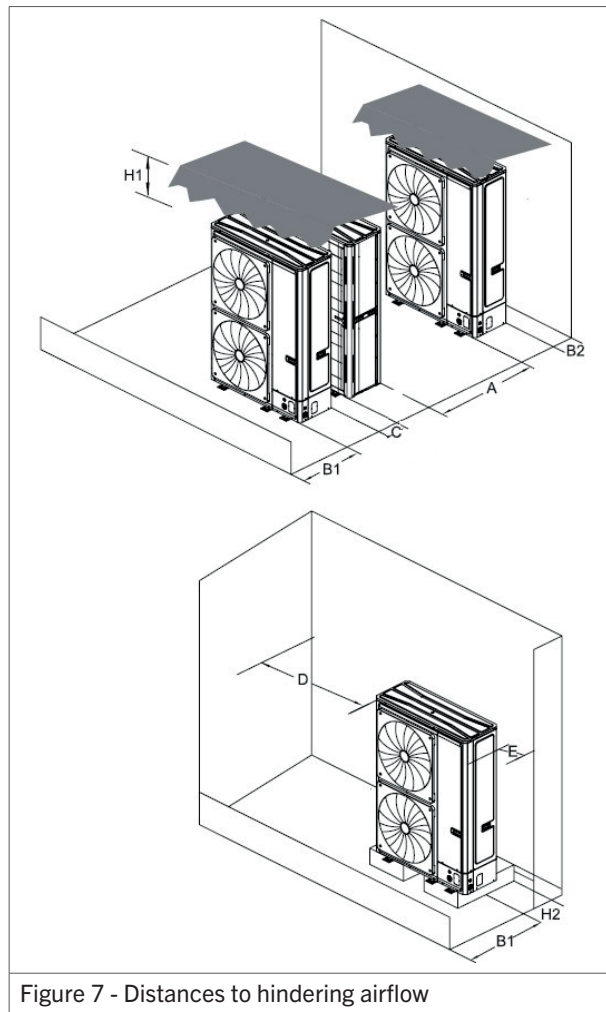
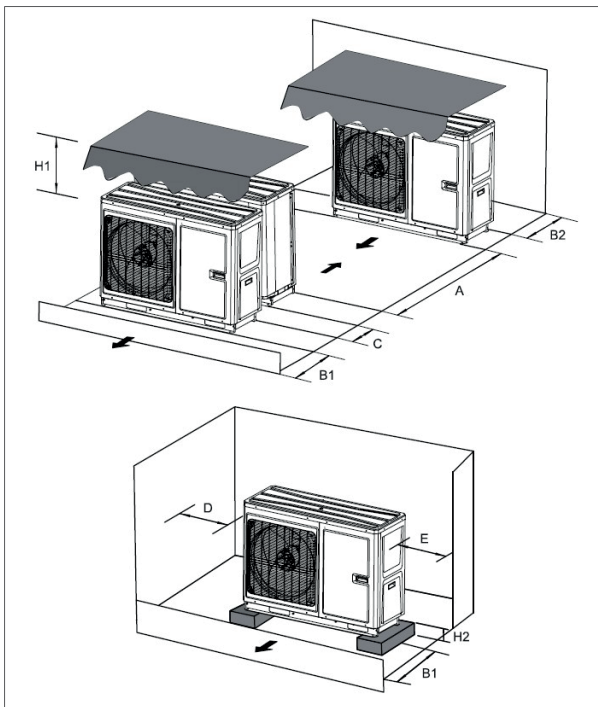

Figure 7 - Distances to hindering airflow

A	> 2000 mm
B1	> 2000 mm
B2	> 200 mm
C	> 400 mm
H1	> 500 mm
H2	> 300 mm
D	> 200 mm
E	> 500 mm

PAY ATTENTION! Considering the limited space as presented in the picture on the top, the distance has to be at least 500 mm between the unit and the closest barrier, this does not apply to the outlet side. For the bottom picture, the distance between the inlet side and the closest barrier cannot be less than 500 mm.

5.2.2. Precautions when installing the heat pump unit

- Use M10 or M12 bolts to mount the heat pump.
- The appliance needs to be installed on a foundation that is at least 300 mm above the bottom.

PAY ATTENTION! Local rules may enforce a bigger distance than 300 mm because of possible excessive snowfall.

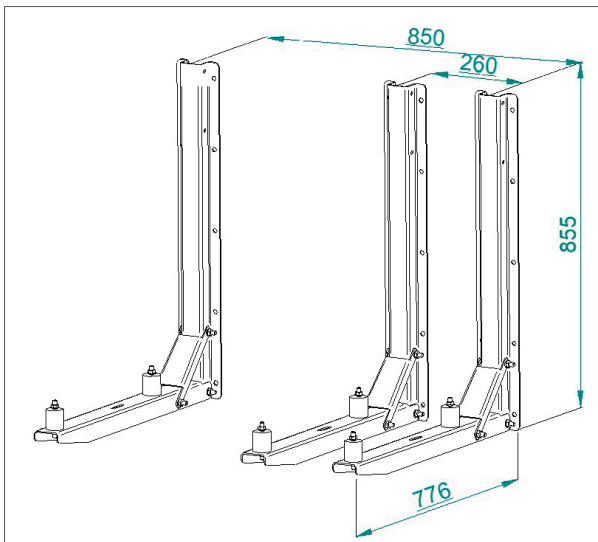

Figure 8 - Dimensions of GA8652

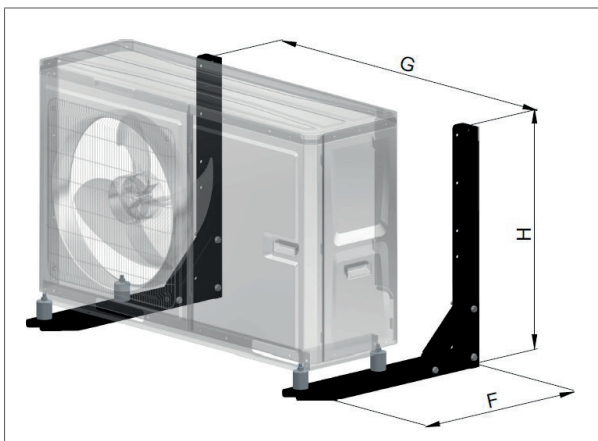

Figure 9 - Wall mounting brackets GA8650

	F	G	H
HPX 06	700	1063	700
HPX 12	700	1120	700
HPX 16	700	1120	700

Accessory	HPX06-12-16	HPX30
Set of rubber levelling blocks L x H = 600 x 95 mm + mounting parts	IW8043 (2 pieces per set) See figure 10.	-
Rubber base block L x H = 1000 x 95 mm + mounting parts	-	IW8036 (per piece, 3 pieces per heat pump)
Set of elevation blocks l x h = 600 x 120 mm	IW8044 (2 pieces per set) See figure 11.	-
Rubber height block L x H = 1000 x 95 mm + mounting parts	-	IW8037 (per piece, 3 pieces required per heat pump)
Wall mounting brackets	GA8650	GA8652

- The appliance needs to be lifted with the designated lifting positions. Ensure that the unit is protected while it is lifted. It is important to refrain from damaging the metal components, to prevent rust formation.



Figure 10 - IW8043



Figure 11 - IW8044

5.2.3. Usage of rubber grommets



Figure 12 - Water return and water supply locations

- 1) Water return
- 2) Water supply

1. Use the long rubber grommets to connect the wiring.
2. Separate the power cable from the control cable.
3. Secure the rubber grommets with a tie wrap after completing the wire connection.

5.3. Closing water side

5.3.1. Installation scheme

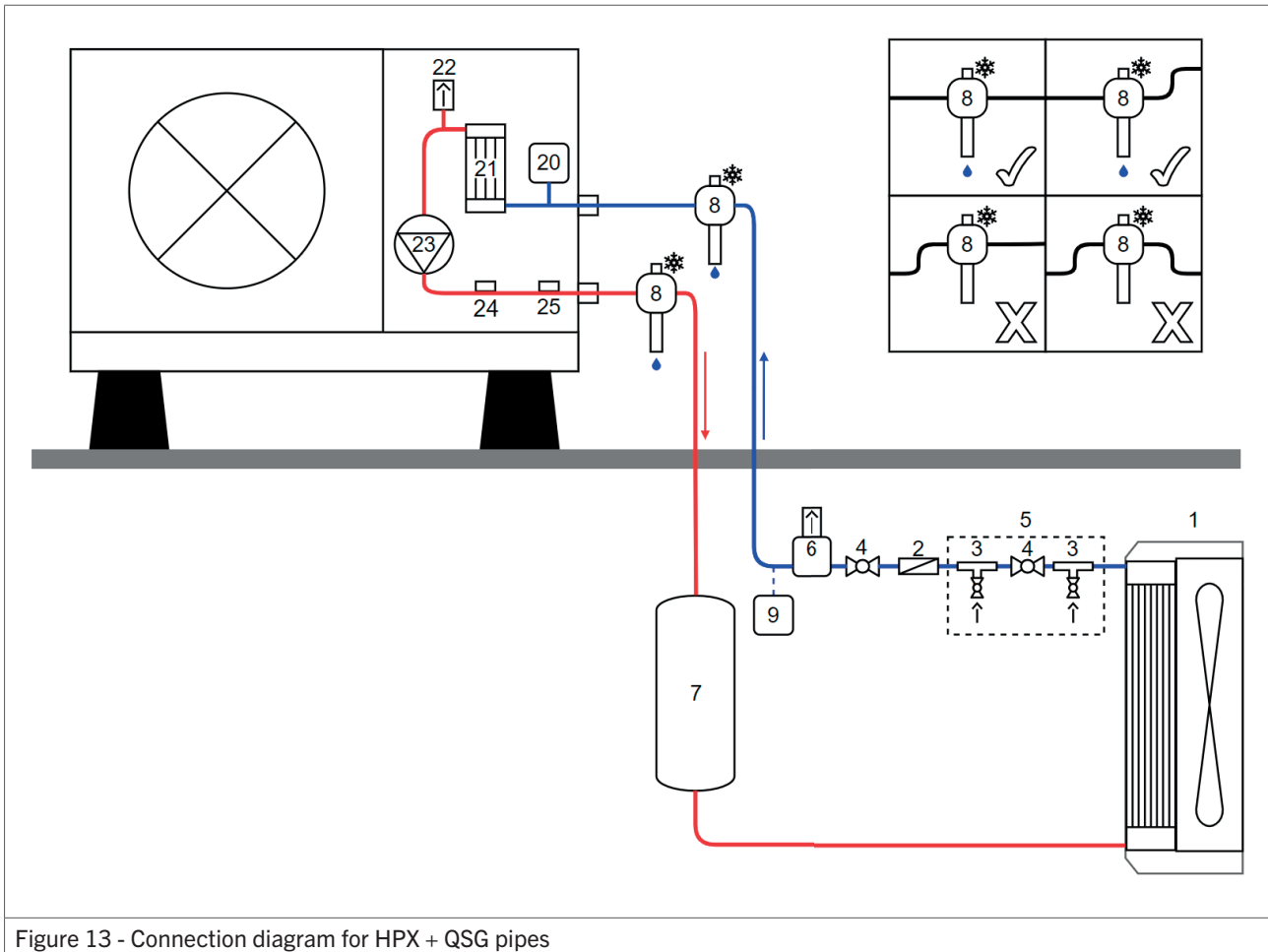

Figure 13 - Connection diagram for HPX + QSG pipes

Part number	Description
1	Indoor unit
2	Water filter
3	Filling point
4	Ball valve
5	Fill & Rinse combination
6	Air separator (flow-through air vent)
7	Buffer tank
8	Frost protection valves
9	Expansion tank
20	Expansion tank (in HPX)
21	Plate heat exchanger (in HPX)
22	Automatic air vent (in HPX)
23	Water pump (in HPX)
24	Water flow sensor (in HPX)
25	Pressure relief valve (in HPX)

5.3.2. Explanation of the components

- Filter:** Install the standard supplied water filter in the system, preferably in the supply line to the heat pump. It is advised to mount the filter between two ball valves, to be able to clean the filter without having to empty and refill the system. Mount filter in return pipe to heatpump in the lowest point possible.
- Filling accessory:** Installing this accessory eases flushing the system until all air is removed, which prevents trapping air into the system during the filling process. The filling accessory can be composed of a ball valve and two T-pieces with small shut-off valves.



Figure 14 - Filling accessory



Figure 15 - A ball valve and two T-pieces with small shut-off valves

- 7 **Buffer tank:** Buffer tank is necessary in case of short piping, where the water volume of the system is less than the value in the table in 5.3.3.
- 8 **Anti-Frost valve:** Place outside, with the opening AND outlet of the heat pump. Place these valves lower than the opening and outlet of the heat pump. The valve will open when the water temperature is below the set value. This low temperature will only be caused by a large electrical breakdown. If glycol or any other means is used to prevent freezing, frost valves do not need to be installed.
- 20 **Expansion tank:** The heat pump has a small internal expansion tank. If the water content of the system is too high, then an extra expansion tank will be needed.
Expansion vessel is necessary when exceeding a certain length only. See the manual of the heat pump for details.
- 21 **Pressure meter:** To check if there is sufficient water pressure in the system, install a pressure gauge. (The pressure cannot be digitally read from the thermostat).

22 **Automatic venting:**

PAY ATTENTION! Air in the pipes is a common cause of disruption. Use an automatic vent that removes small air bubbles from the water. Simple cheap vents will usually not do the job. One quality vent should be enough, but optionally a vent in both the supply and return line are recommended.



Figure 16 - Air vent

- 25 **Expansion Valve:** The heat pump is provided with a pressure safety valve that opens when the water pressure becomes too high. For extra safety measures, install an extra expansion valve.

5.3.3. Expansion tank and water content

The heat pump has an internal expansion tank. The storage of this expansion tank is not very large, but generally sufficient to create a good installation. An extra expansion tank will not be needed. Read below when it is required to install an extra expansion tank.

Table for deciding whether an extra expansion tank is required:

Type	Built-in expansion tank	Maximum system storage without extra expansion tank
HPX06A	2 litres	35 litres
HPX12A - HPX16A	3 litres	55 litres
HPX30A	10 litres	205 litres

Maximum system storage: Do not take the contents of the heat pump and the distribution system in this calculation. This only refers to the piping and any additional fittings. If the system capacity is exceeded, an extra expansion tank must be installed.

Minimum system capacity: for the pump to function properly and to ensure a reliable defrost cycle for the outdoor unit in winter, the MINIMUM system capacity specified below must be maintained. These values do NOT include the capacity of the built-in expansion vessel. They refer to the capacity of all pipes, the delivery system and any buffer tank.

Model	Minimum system capacity (L)
HPX06	20
HPX12	30
HPX16	40
HPX30	70

5.3.4. Pipe diameter and pipe length

Do not install pipes with an internal diameter that is too small.

Internal diameters that are too small cause excessive resistance to the high water flow of the heat pump.

Do not use an INTERNAL DIAMETER smaller than 25 mm (1 inch) with the HPX06A-HPX16A, and do not use an INTERNAL DIAMETER smaller than 38 mm (1.5 inches) with the HPX30A.

If the pipe is too long or has too many bends, the resistance of the pipes will become too great. In this case, use a larger diameter to prevent malfunctions with the heat pump.

If you are unsure about the water-side resistance, have it checked by an expert. It is better to use a larger internal diameter for the pipes. It is expensive to replace a pipe once it has been installed if faults occur.

Practical tips:

- Use corrugated pipes as little as possible. These pipes are very flexible and easy to install, but they also have very high internal resistance.
- Try to minimise the number of turns and avoid short sharp turns (knee).

5.3.5. Filling pressure

The expansion tank in the unit has a pre-pressure of 1.5 bar. The system filling pressure should preferably be between 1.5 and 2 bar. The device has a hydraulic working range of 0.5-2.5 bar. If the pressure exceeds 2.5 bar, the safety mechanism will be triggered, and water will be discharged.

5.3.6. If the air heater is installed at a higher location than the heat pump

If the air heater is installed 12 metres higher than the heat pump, the pressure in the built-in expansion tank will be too low. The pressure will need to be increased in such cases. Please contact your distributor if this applies to your installation. It is possible that the installation may not be feasible.

5.3.7. Maximum allowable resistance and minimum flow

The heat pump moves a large amount of water. It moves much more water than a traditional central heating boiler.

Therefore, use pipes with a sufficiently large diameter and as few bends as possible.

The heat pump is equipped with an internal modulating water pump. The minimum flow required by this pump to function properly is:

Type	Minimum flow (m ³ /h)	Maximum resistance pipe system (m _{wk})
HPX06A	1.1	7.7
HPX12A	1.5	7.1
HPX16A	2.0	5.6
HPX30A	3.4	13.8

CAUTION! If the maximum flow is not achieved, the heat pump will not be at its full capacity and might malfunction.

5.3.8. Available external static pressure on the exhaust pipe

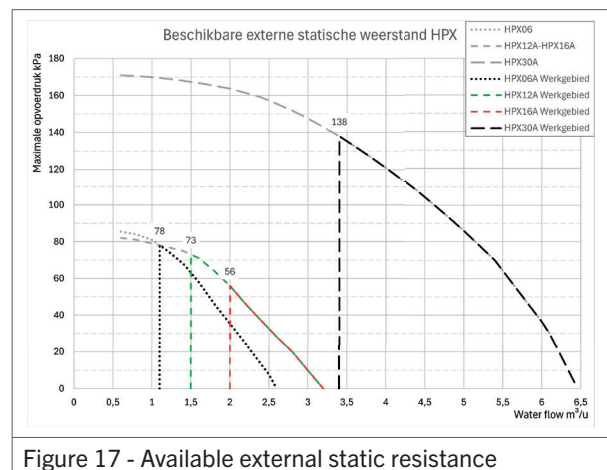

Figure 17 - Available external static resistance

Note: See the curve above for the maximum external static pressure. The water pump has a variable frequency. While operating the water pump will change the power based on the actual loading.

5.3.9. Requirements for water quality

To prevent issues in the water circuit, the water has to meet the quality criteria below.

Parameter	Parameter value	Unit
pH (25°C)	6.8 - 8.0	-
Turbidity	< 1	NTU
Chloride	< 50	mg/L
Fluoride	< 1	mg/L
Iron	< 3	mg/L
Sulfate	< 50	mg/L
SiO ₂	< 30%	mg/L
Hardness (CaCO ₃)	< 70	mg/L
Nitrate (telling N)	< 10	mg/L
Conductivity (25°C)	< 300	ηs/cm
Ammonia (number N)	< 0.5	mg/L
Alkalinity (amount CaCO ₃)	< 50	mg/L
Sulfide	Under the range of detectability	mg/L
Oxygen	< 3	mg/L
Sodium	< 150	mg/L

Note: When the circulation water does not meet the criteria in the table, add a water softener.

5.3.10. Filling procedure

NOTE Before commissioning, the dust cap on the automatic air vent must be loosened by two turns. However, in the event of leakage, it must be tightened.

PAY ATTENTION! This is an automatic air vent, not a pressure relief valve!



Figure 18 - Cap automatic air vent

Open all air vents and start filling the system with water or water mixed with antifreeze.

Use a filling accessory as in figure 14 and 15. Open both the supply and return valve and close the middle valve. Keep supplying water until no more air comes out of the return valve to make sure the system is air-free. Then close both the supply and return valve and open the intermediate valve.

5.4. Electrical connection

5.4.1. General principles

- Cables, wires, devices, and connectors that are used at the location, have to comply with the applicable regulations and technical requirements.
- Only installers with the right qualifications are allowed to operate the wiring at the location.
- The power supply has to be shut off before the connection work begins.
- The installer is responsible for possible damages that may be caused by connecting the external switch incorrectly.

5.4.2. A general reference for connecting the power supply to the heat pump

- Power cables have to be installed via cable trays, pipes, or cable channels.
- Power cables that are connected to the electrical box have to be protected with rubber or plastic, to prevent scratches through the edge of metal plates.
- Power cables close to the electrical box have to be reliably installed, to ensure that the connection points in the box do not experience external force.
- The power cable has to be reliably grounded.

5.4.3. Specification of the power supply and earth leakage circuit breaker

Type	EL supply	Work switch	Minimum diameter	Earth leakage protection
HPX06A	230 V AC, 50 Hz	16 A	2.5 mm ²	<0.1 s, 30 mA
HPX12A - HPX16A	400 V AC, 3P+N 50 Hz	16 A	2.5 mm ²	<0.1 s, 30 mA
HPX30A	400 V AC, 3P+N 50 Hz	25 A	4 mm ²	<0.1 s, 30 mA

- If the distance from the heat pump to the power distribution device is larger than 75m, then the wire diameter must be increased.
- The heat pump must have its own electrical circuit.
- The cable specifications mentioned above apply to the multi-core cable protected by a conduit (for example, YJC XLPE insulated power cable) used at 40°C and withstanding 90°C (see IEC 60364-5-52). If the installation conditions change, they must be adjusted according to the relevant national standard.
- The specifications of the switch listed in the table above apply to the switch with an operating temperature of 40°C. If the operating conditions change, they must be adjusted according to the relevant national standard.

Open the side panel to make the connection. The power supply voltage should be connected to terminal block XT1.



Figure 19 - Terminal block XT1

5.4.4. Unit type HPX06A, 1-Phase 230V connection

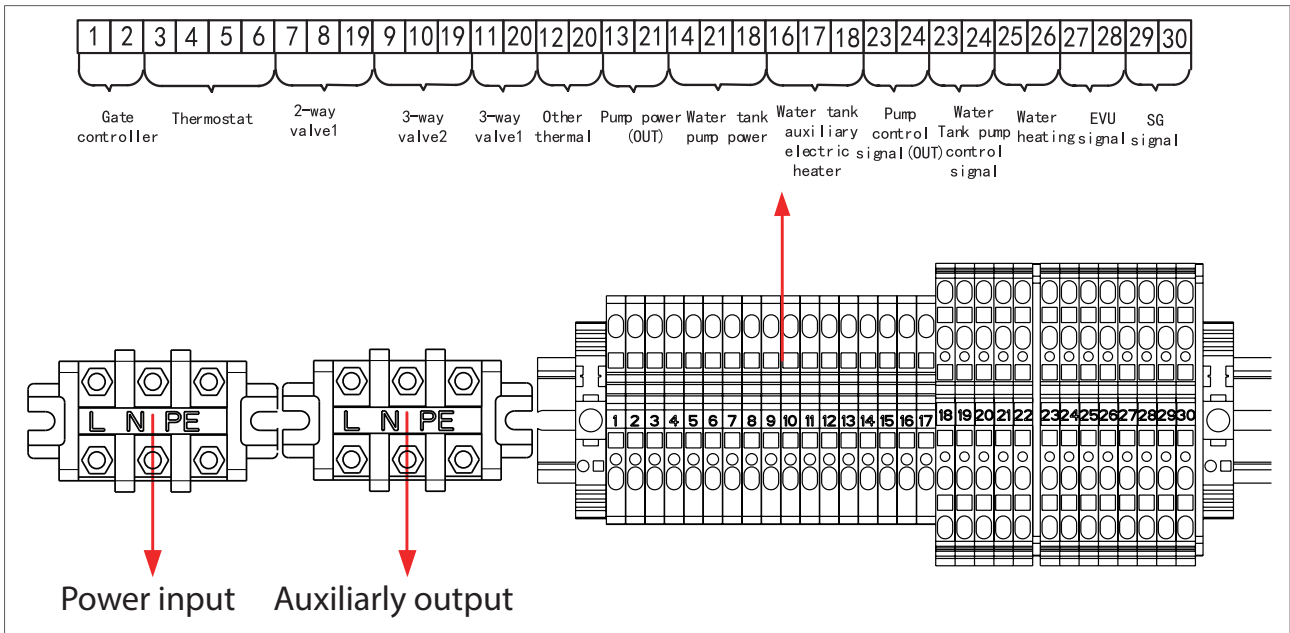

Figure 20 - Connections HPX06A

5.4.5. Model type HPX12A / HPX16A / HPX30A
3-Phase +N 400V connection

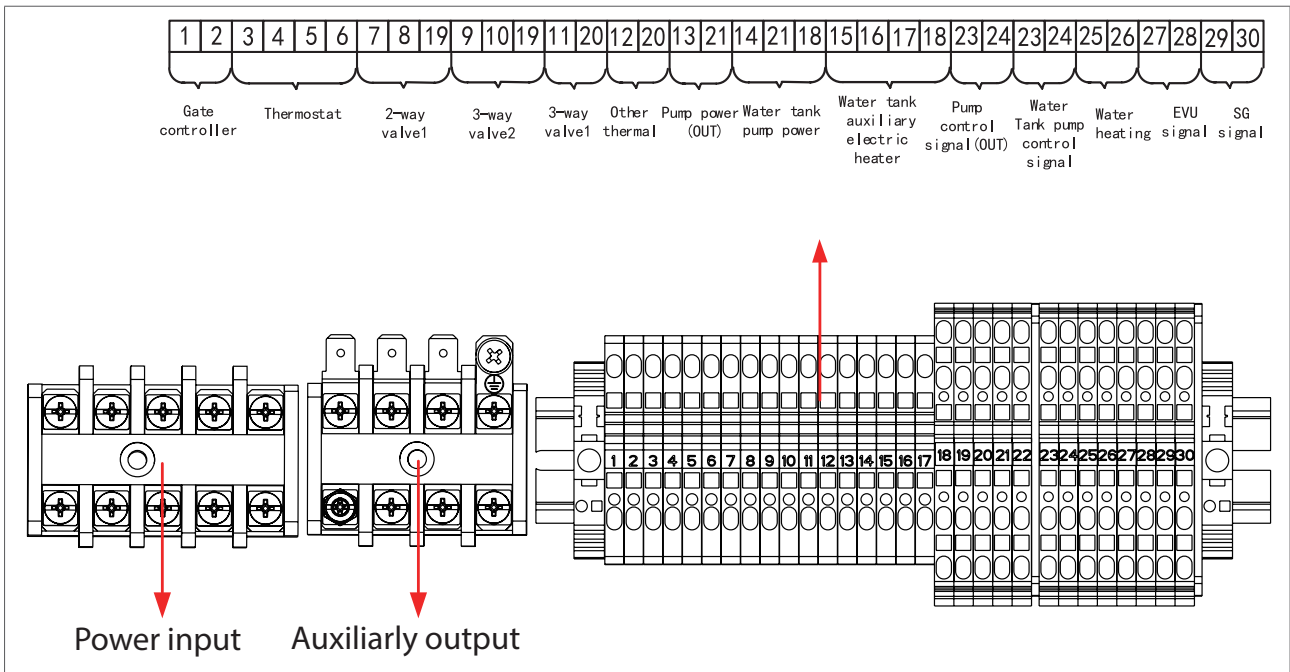

Figure 21 - Connections HPX12A - HPX16A - HPX30A

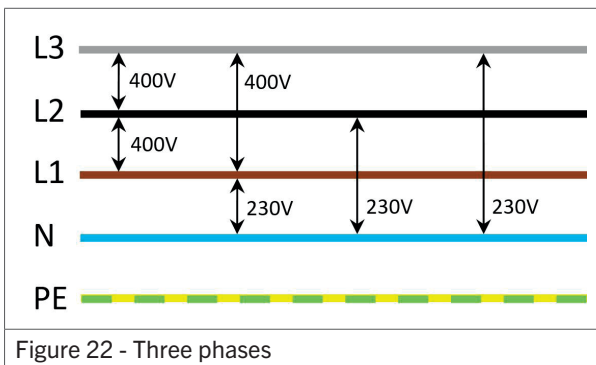

Figure 22 - Three phases

CAUTION! The heat pump must be connected to a clockwise rotating field!



Figure 23 - Rotating field

HPX30A only: when the heat pump is connected to a left-turning rotary field, the unit will not start and the system will display the following error code: ODU com./iDU com.

5.4.6. Connecting the communication cable

In all cases, the communication between the heat pump, air heater, and the thermostat is based on a two-wire low-voltage connection (refer to the electrical diagram). Follow these instructions to prevent installation malfunctions and damage to the heat pump, thermostat, or air heater.

Use a cable with the following specifications:

- Signal cable
- Shielded
- Minimum dimensions: $2 \times \varnothing 0.34 \text{ mm}^2$.
- Maximum length: 200 m.

CAUTION! Keep the communication cable separate from the power cables.

CAUTION! Only connect the cable's shielding to the grounding terminal in the heat pump. Do not connect the other end of the cable's shielding.

PAY ATTENTION! A cable with a wire diameter of less than 0.34 mm^2 will result in poor signal quality.

PAY ATTENTION! A non-shielded cable may cause disrupted communication in an EMC-unfriendly environment.

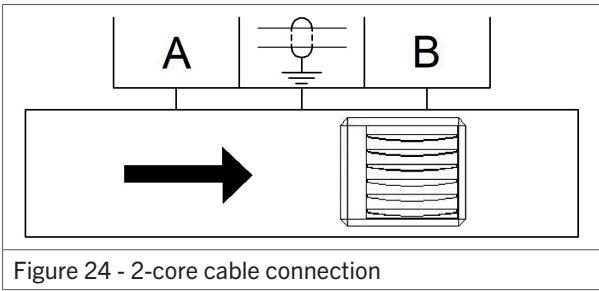

Connect the 2-core cable to the terminal strip as shown in figure 24.

5.4.7. Other optional connections

The device has more optional connections, besides the power cable and control cable. These are not required when a (hybrid) air heater is used. Below is a short description of the optional connections:

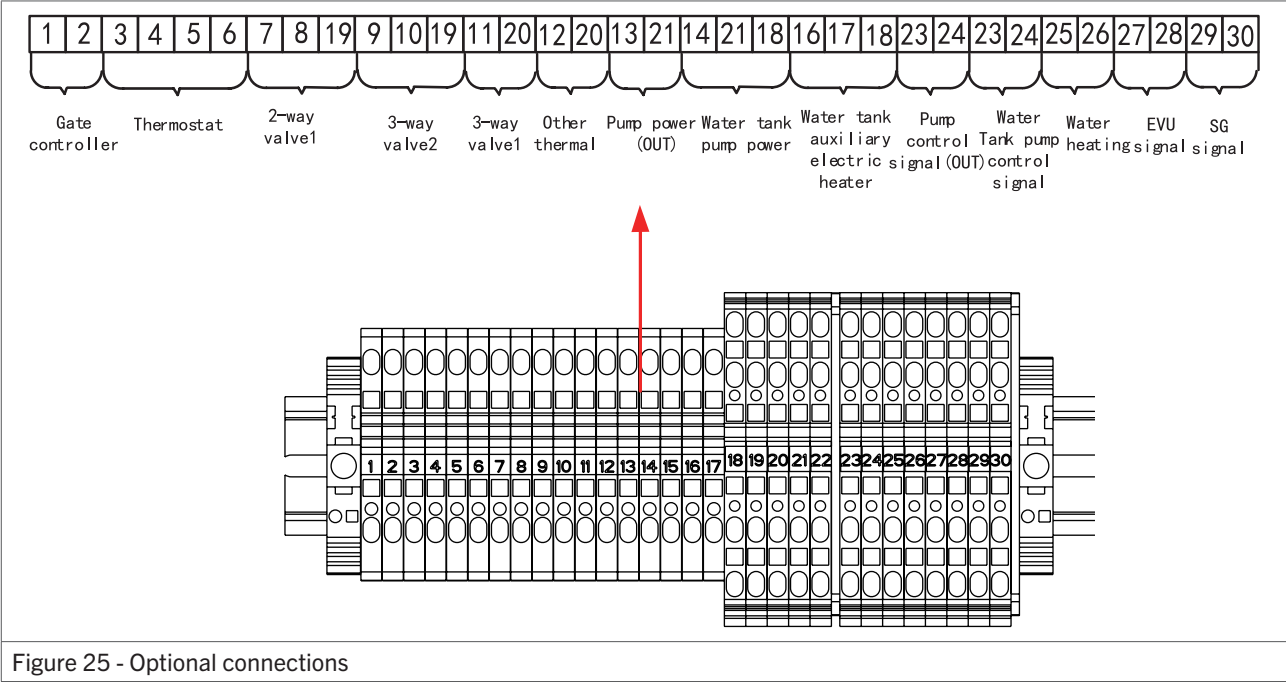

Figure 25 - Optional connections

6. Activities related to the refrigerant circuit

6.1. General

PAY ATTENTION! Actions regarding the refrigerant circuit can only be conducted by certified individuals.

- Generally, NO actions have to be performed on the refrigerant circuit during the installation. There is no F-gasses certification requirement for the installation.

6.1.1. Safe usage of flammable refrigerants

6.1.1.1. Qualification requirements for installation and maintenance

Every employee involved with the cooling system has to be in possession of a valid certificate that is given by an acknowledged organization and needs to have the required qualification to operate cooling systems, as recognized in this industry. If other technicians are required to maintain or repair the device, they must be supervised by someone qualified to work with flammable refrigerant. Repairs can only be executed according to the methods proposed by the manufacturer of the appliance.

6.1.1.2. Installation-instructions

- The device cannot be used in a place where open flames are present (such as open flames, a functioning gas installation, or an operating heat system).
- Only install the device outdoors.
- After installation, a leak test must be carried out using a suitable leak detection device.

6.1.2. Maintenance instructions for refrigerant circuit

- Check whether the maintenance area or space meets the requirements. Operating the device is only allowed in spaces that meet the requirements.
- Check whether the maintenance area is properly ventilated. Continuous ventilation needs to be maintained during operations.
- Check whether sources of ignition or flames are present in the maintenance area. Open flames are prohibited in the maintenance area, and a “no smoking” warning sign must be displayed.
- Check if the device label is in good condition. Replace a faded or damaged warning sticker.

6.1.3. Welding

If the pipes of the cooling system have to be cut or welded during the maintenance process, follow the following steps:

1. Turn off the device and interrupt the power supply.
2. Remove the refrigerant.
3. Vacuuming.
4. Clean the device with N₂-gas.
5. Cut or weld.
6. Bring it back to the service station for welding.

The refrigerant has to be regained in the special storage tank.

DANGER! Ensure that there is no open fire near the exhaust of the vacuum pump and that it is well-ventilated.

6.1.4. Filling the refrigerant

- Use the refrigerant filling equipment specialized for R32. Ensure that different types of refrigerants are not mixed.
- Keep the refrigerant tank upright during the filling process.
- Attach the label on the system after the filling is completed (or not quite yet).
- Do not overfill the refrigerant.
- After filling, a leak detection test has to be performed before starting the test run; leak detection has to be performed again when it is removed.

6.1.5. Safety instructions for transport and storage

Use an inflammable gas detector to verify before unloading and opening the container. open flames and smoking are dangerous. Respect the local rules and laws.

6.2. Filling and draining the refrigerant

The device will be filled with refrigerant prior to delivery. A shortage or excess of refrigerant can lead to suboptimal functioning of the compressor or damage. When filling or draining refrigerant is necessary during the installation, for maintenance or other reasons, follow the steps below and the quantity mentioned on the rating plate.

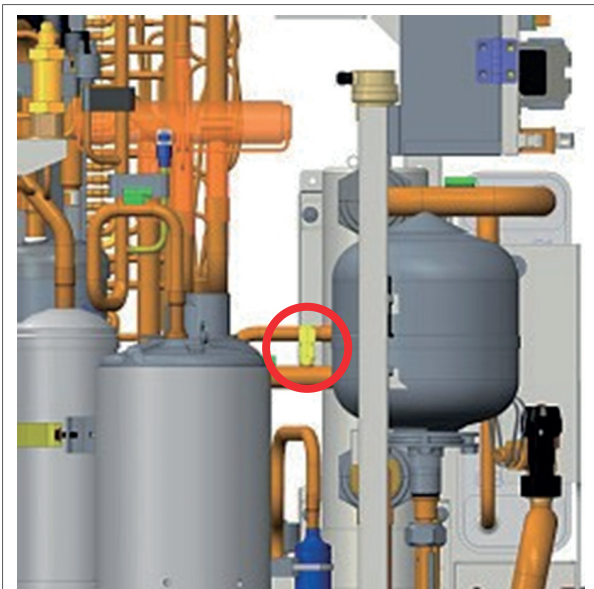

Figure 26 - Filling valve 1

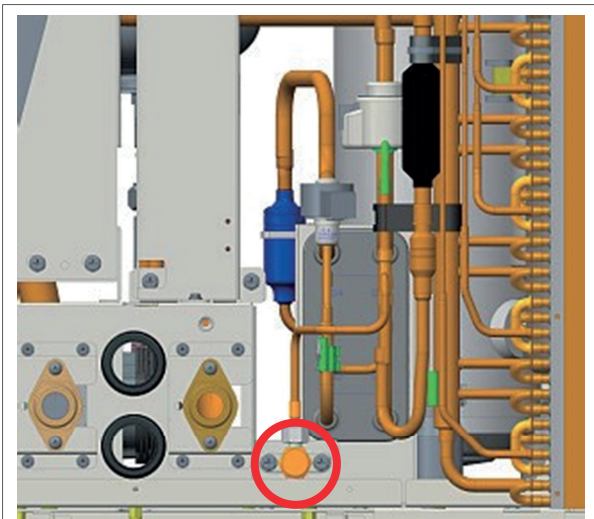

Figure 27 - Filling valve 2

Note:

- Discharge is not allowed unless the unit has stopped. (Switch off the power and turn it on 1 minute later).
- While discharging, take protective measures to prevent freezing.
- When the draining process is complete and vacuuming cannot be performed immediately, remove the pipe to prevent air and foreign substances from entering the unit.
- Vacuuming: After the drainage is completed, connect the pipes to the filling valve, the pressure gauge, and the vacuum pump to vacuum the unit (see figure28).

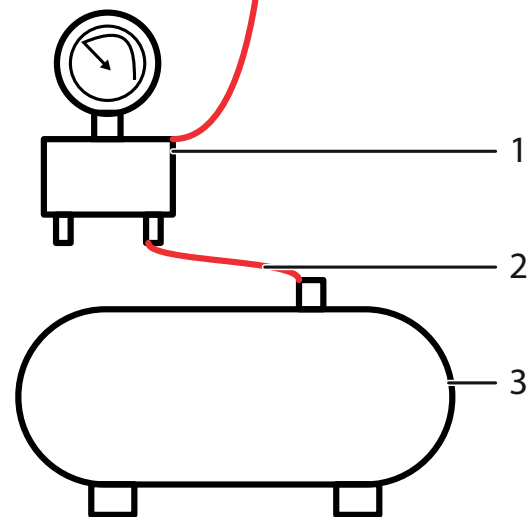
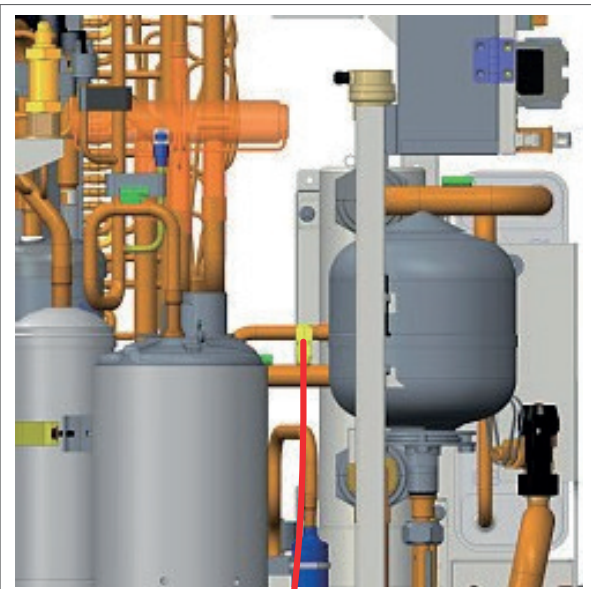

Figure 28 - Vacuuming

Note: When the vacuuming is completed, keep the pressure lower than 80Pa for at least 30 minutes to verify that there are no leaks. Both filling valves 1 and 2 can be used for vacuuming.

Filling: When the vacuuming is completed and it is verified that there are no leaks, the filling can start.

6.3. Leakage detection

1. Use leak detection methods considered acceptable for systems containing flammable refrigerants.
2. The electronic leak detector can be used to discover flammable refrigerants, but the sensitivity may not be sufficient or may require recalibration (detection equipment needs to be calibrated in a refrigerant-free space).

3. Verify that the detector is not a potential source of ignition and that it is suitable for the refrigerant used.
4. Leak detection equipment has to be set to a percentage of the refrigerant's LFL and calibrated to the specific refrigerant used, with the correct gas percentage confirmed (up to 25%).
5. Leak detection fluids are suitable for most refrigerants, but the use of chlorine-containing substances should be avoided as chlorine can react with the refrigerant and corrode copper piping.
6. If a leak is suspected, all open flames need to be removed/extinguished. If refrigerant leakage

requiring soldering is found, all refrigerant must be recovered or isolated (Using shut-off valves) in a part of the system away from the leak. Oxygen-free nitrogen has to be flushed through the system both before and during the soldering process.

PAY ATTENTION! Use a suitable refrigerant leak detector to monitor the environment before and during use, ensuring that technicians can be well-informed of potential or actual leakage of flammable gas. Make sure the leak detection device is suitable for flammable refrigerants, for example, free of sparks, fully sealed, and safe in nature.

7. Commissioning

7.1. Checklist

Before using the device, the checklist below has to be filled in.

If the list below is not filled in correctly, it may lead to rejection of service requests.

This table has to be filled in by the installer.		
Confirm with the installer, dealer, and customer that the following tasks have been completed.		
No.	Description	OK?
1	Has the installation been carried out by properly qualified individuals?	Y/N
2	Are the installation and troubleshooting manuals stored correctly?	Y/N
3	Is the appearance of the device undamaged?	Y/N
4	Is the internal piping in the device undamaged?	Y/N
5	Is the delivery of the device and accessories complete?	Y/N
6	Are the installation drawings for the piping and the electricity available?	Y/N
7	Verify that the device is stable and that there is sufficient space for servicing.	Y/N

This table has to be filled in by the installer.		
Confirm with the installer, dealer, and customer that the following tasks have been completed.		
No.	Description	OK?
8	Are the distances in relation to obstructions maintained, and is there at least 300mm space between the bottom of the heat exchanger and the installation surface?	Y/N
9	The refrigerant circuit is undamaged, and there are no leaks detected.	Y/N
10	The frost protection valves have been installed, or the system is filled with glycol.	Y/N
11	Water-side fittings are connected properly (filter, pressure gauge, thermometer, vents, ball valves, etc.)	Y/N
12	The water system is properly vented, pressurized and free of leaks, the valves are opened.	Y/N
13	The electrical supply is in line with the nameplate specifications.	Y/N
14	The device is properly grounded and the cable diameters are consistent with the requirements.	Y/N
15	The cables are strain-relieved.	Y/N
16	The device can be turned off with a main power switch.	Y/N
17	Have the transport foot brackets of the compressor been removed?	Y/N
18	Has the dust-proof cap of the internal automatic relief valve been loosened two turned?	Y/N

7.2. Test run

PAY ATTENTION! Before starting the testing, check the following:

1. Before starting up the device, it should be powered on for 8 hours. This is necessary to preheat the system and the compressor oil. Failure to do so may result in damage to the compressor. The voltage should be within +/- 10% of the required voltage.
2. **PAY ATTENTION!** FIRST connect the heat pump to the power supply and THEN connect the indoor unit (air heater). Connecting them in the wrong order may disrupt communication.
3. After powering the device, use a multimeter to measure the voltages between the terminal connections. Check that the phases are correctly connected with a clockwise rotating field and if there is no voltage on the ground. In the event of a counter-clockwise rotating field, the unit may display the following error message: ODU Com./ IDU Com. In this case, reverse two of the three phases. See Figure 22 and 23.
4. **WARNING!** The foot brackets (having been labelled) are used for prevention of the compressor jolting during transport. Remove the support and bracket before commissioning in case faulty operation occurs. Fastening screws must be tightened to prevent the compressor from jumping out during operation.

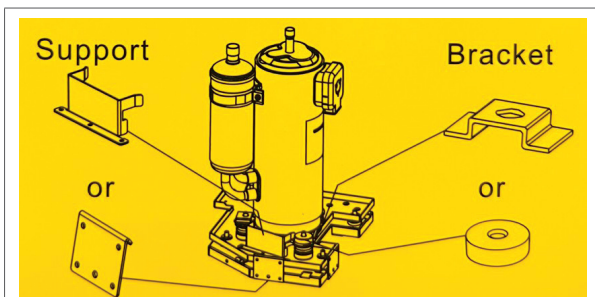

Figure 29 - Remove foot brackets compressor

5. The main power switch must be easily accessible so that in case of abnormal operation, the device can be quickly powered off. This can prevent damage to the device and ensure safety for individuals.
6. After starting up the device, observe (look and listen) the operation of the compressor, expansion valve, fan, and water pump. If any abnormal observations are made, the device should be turned off.

7.3. Control panel

7.3.1. General

Note: The heat pump is externally controlled if it is connected to a QSE, QSG or Modbusrouter. There is no need to change any settings and the display. The display in the heat pump is for commissioning purposes only.

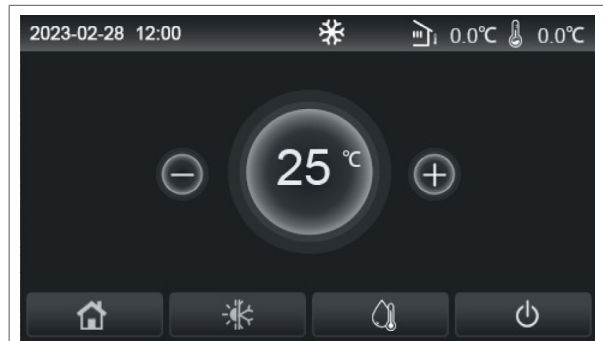

figure 30 - Home Page

(This picture is just for reference)

When the control panel is switched off, the display turns black. The black area between the top and bottom bars is the touch area that can be used to switch the control panel back on.

This control panel is of high sensitivity and will respond to unexpected click by the foreign matters on the display panel. Therefore, please keep it clean during operation.

This is a control panel with extensive purposes, whose control functions might not be completely the same as those of the actually purchased. As the control program will update, the actual always prevails.

The unit is equipped with temperature sensors such as remote room temperature sensors, outlet water temperature sensors, etc., and pressure sensors. Among them, the temperature sensors are used to detect outdoor, indoor, outlet water temperature, etc. The pressure sensors are used to detect the pressure value at the discharge port which then will be converted into temperature values through their relationship. All of them are to detect the operating state of the unit itself, make the unit run stably, and display the operating state on the control panel in real time.

7.3.2. Home Page

A number of icons are visible on the home page.

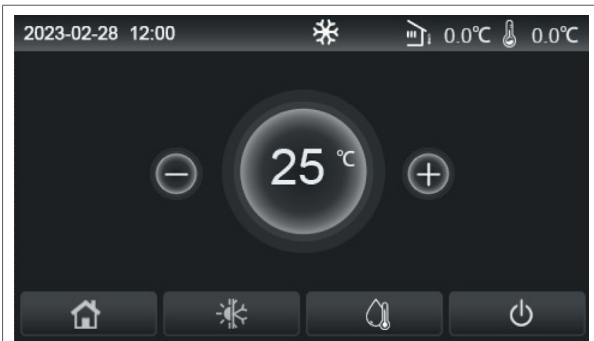

figure 31 - Home Page

The following table provides an overview of the icons and their meanings.

Icon	Description
	Space heating
	Space cooling
	Water heating
	Menu
	Switchover between cooling and heating
	Child lock
	Outdoor temperature
	Leaving water temperature of the main unit, leaving water temperature of the auxiliary electric heater, remote room temperature, water tank temperature
	Error/malfunction
	Card out/Failed disinfection
	On/Off
	The main unit keeps the standby status under the SG control command.

Note: The On/Off icon turns green when the heat pump is switched on (possibly via an external signal).

Note: The control panel will switch off if it is not touched for 5 minutes.

7.3.3. Menu Page

A number of menus and icons are visible on the main page.

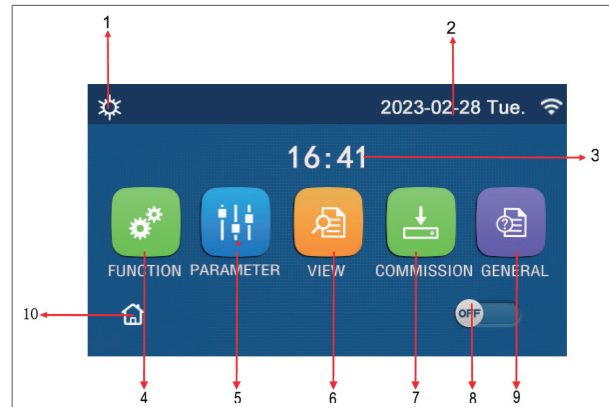

figure 32 - Menu Page (language setting: English)

No.	Item	Description
1	Control mode	Current mode
2	Date	Current date
3	Time	Current time
4	Function	Go to the functions page.
5	Parameter	Go to the parameter setting page.
6	View	Go to the status display page.
7	Commissioning	Go to the page with function and parameter settings.
8	On/Off	The button indicates whether the heat pump is switched on or off, possibly via an external signal. 'OFF' indicates that there is no heating or cooling demand and 'ON' indicates that there is a heating or cooling demand. If an error or malfunction occurs, this button is automatically set to 'OFF'.
9	General	Go to the general settings page.
10	Homepage	Back to the home page.

Note: As soon as an error occurs, the heat pump will switch off automatically. The On/Off button will then be set to 'OFF' automatically.

Icon	Description
	Heating
	Cooling

Icon	Description
	Hot water
	Heating + Hot water
	Hot water + Heating
	Cooling + Hot water
	Hot water + Cooling
	Quiet
	Sanitation
	Emergency
	EVU
	Floor commissioning
	Floor commissioning error
	Card out
	Defrosting
	Holiday
	Wifi
	Back
	Menu Page
	Save
	Error/malfunction

In the event of a malfunction, the error/malfunction icon (red exclamation mark) appears at the top left of the screen:

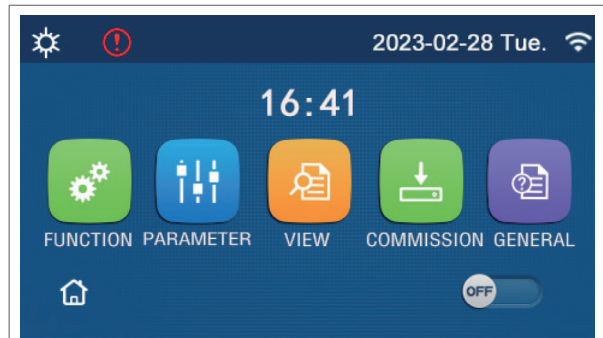

figure 33 - Error/malfunction Icon (language setting English)

7.3.4. Adjust general settings

General settings can be changed in the General menu. The following table provides an overview of the settings that can be adjusted:

Page	Item	Range	Standard setting to
1	Temp. unit	°C/°F	°C
	On/off memory	On/Off	Off
	Beeper	On/Off	Off
	Back light	Lighted / Energy save	Energy save
	Time&Data	Enter	-
2	Language	Italiano/English/ Español/Nederlands/ Français/ Deutsch/Български/ Polski/Suomi/ Svenska/Türkçe/ Magyar/Lietuvių/ Hrvatski/Čeština/ Srpski/Slovenski/...	English
	Wifi	On/Off	On

The following sections explain how to change a number of general settings.

7.3.4.1. Set control panel language

Note: The control panel language is set to English by default.

The language can be adjusted as follows:

1. Tap **GENERAL** in the main menu.
2. Tap > to scroll to the second page.
3. Tap **Language: English**.
A list of available languages will appear on the screen.
4. Scroll through the list and select the desired language.

5. Tap the **Storage icon** at the top right of the screen to confirm your selection.
The message “Saved successfully!” appears. The list of available languages then reappears.
6. Return to the main menu by tapping the **Back icon** at the top left of the screen twice.

7.3.4.2. Set control panel backlight

You can decide whether the backlighting of the control panel remains on or whether it switches off automatically when the control panel has not been touched for 5 minutes.

Note: The backlight is set to 'Energy saving' by default. This setting extends the service life of the control panel.

The backlight setting can be adjusted as follows:

1. Tap **GENERAL** in the main menu.
2. Tap **Back light: Energy save**. The setting changes to 'Back light: Lighted'.
Tapping **Back light: Lighted** changes the setting back to 'Back light: Energy save'.
3. Return to the main menu by tapping the **Back icon** at the top left of the screen.

7.3.4.3. Set time and date

The time and date are set as follows:

1. Tap **GENERAL** in the main menu.
2. Tap **Time&Date: Enter**.
A screen will appear. The set date and time will be displayed at the top and again below in a blue frame.
3. Set the new date and/or time within the blue frame. Scroll up or down per column until the desired value is displayed.
4. Tap the **Save icon** at the top right of the screen to confirm your selection.
The message 'Saved successfully!' will appear. The set date and time will then be displayed again.
5. Return to the main menu by tapping the **Back icon** at the top left of the screen twice.

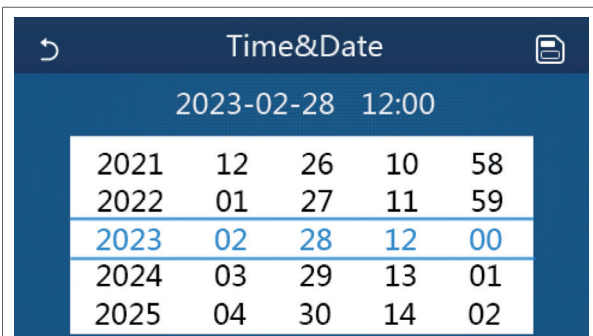

figure 34 - Setting the date and time (language setting: English)

7.3.5. Set On/Off memory

You can decide whether the control panel should switch on automatically once power has been restored after a power failure.

Note: The 'On/Off memory' setting is set to 'Off' by default.

The On/Off memory is set as follows:

1. Tap **GENERAL** in the main menu.
2. Tap **On/off memory: Off**. The setting changes to 'On/off memory: On'.
Tapping on **On/off memory: On** changes the setting back to 'On/off memory: Off'.
3. Return to the main menu by tapping the **Back icon** at the top left of the screen.

Note: The On/off memory can also be set in the main menu. Slide the button at the bottom right of the screen to the right (ON) to ensure that the control panel switches on automatically once power is restored after a power failure. Slide the button to the left (OFF) to ensure that the control panel remains switched off.

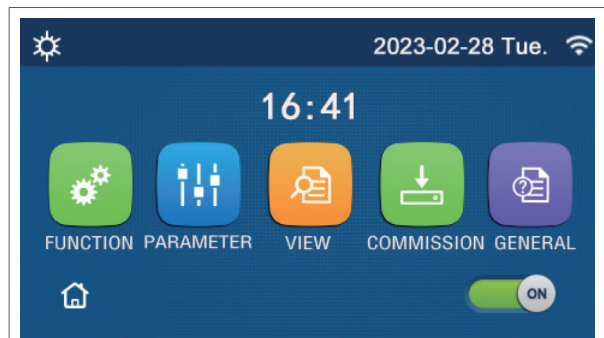

figure 35 - Set power memory to ON (language setting English)

7.3.6. Set air removal

PAY ATTENTION! Only activate venting AFTER refilling the system with water.

Note: This setting is saved if the power is cut off.

The air removal is set as follows:

1. Set the On/off memory to 'OFF' (see § 7.3.5).
Note: If you leave the memory set to ON, the error message 'Switch off the system first!' will appear in step 6..
2. Touch and hold **COMMISSION** in the main menu for 5 seconds.
Note: The message “Please contact the equipment manufacturer to modify the commissioning parameters” appears on the screen if you do not touch **COMMISSION** long enough.
If this is the first time this menu has been opened,

a screen will appear asking you to create a new password. Continue with step 3.

If this menu has been opened before and you already have a password, proceed to step 5.

PAY ATTENTION! Some devices have a pre-programmed password. In that case, the password is 000048.

3. Enter the desired password and confirm the code by tapping **OK**.
- PAY ATTENTION!** Keep this code safe.
4. Touch and hold **COMMISSION** in the main menu for 5 seconds.
5. Enter your password and confirm the code by tapping **OK**.
6. Tap **FUNCTION**.
7. Tap > to scroll to page 2.
8. Tap **Air removal: Off**.
9. Select 'Air'.
10. Confirm your selection by tapping **OK**.
11. Return to the main menu by tapping the **Back icon** at the top left of the screen twice.

Note: In the COMMISSION menu, FUNCTION submenu, you can reset your password. Scroll to page 6 and tap **Password: Enter**.

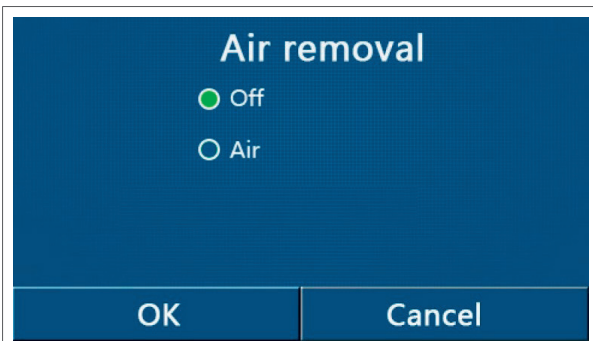

figure 36 - Set air removal (language setting English)

7.3.7. Set manual defrost

Setting the “Manual defrost” function immediately activates the heat pump's defrost mode. Defrosting stops:

- when the defrost temperature has reached 20 °C; or
- when the defrost period is 10 minutes.

Note: This setting is saved if the power is cut off.

Manual defrosting is set as follows:

1. Set the On/off memory to 'OFF' (see § 7.3.5).
Note: If you leave the memory set to ON, the error message 'Switch off the system first!' will appear in step 6..
2. Touch and hold **COMMISSION** in the main menu

for 5 seconds.

Note: The message “Please contact the equipment manufacturer to modify the commissioning parameters” appears on the screen if you do not touch **COMMISSION** long enough.

If this is the first time this menu has been opened, a screen will appear asking you to create a new password. Continue with step 3.

If this menu has been opened before and you already have a password, proceed to step 5.

PAY ATTENTION! Some devices have a pre-programmed password. In that case, the password is 000048.

3. Enter the desired password and confirm the code by tapping **OK**.
- PAY ATTENTION!** Keep this code safe.
4. Touch and hold **COMMISSION** in the main menu for 5 seconds.
5. Enter your password and confirm the code by tapping **OK**.
6. Tap **FUNCTION**.
7. Tap twice on > to scroll to page 3.
8. Select 'On'.
9. Confirm your selection by tapping **OK**.
10. Return to the main menu by tapping the **Back icon** at the top left of the screen three times.

Note: In the COMMISSION menu, FUNCTION submenu, you can reset your password. Scroll to page 6 and tap **Password: Enter**.

7.3.8. Menu View

In the View menu, you can view the following information about the main unit:

- Status
- Parameters
- Errors
- Error log
- Programme and protocol version

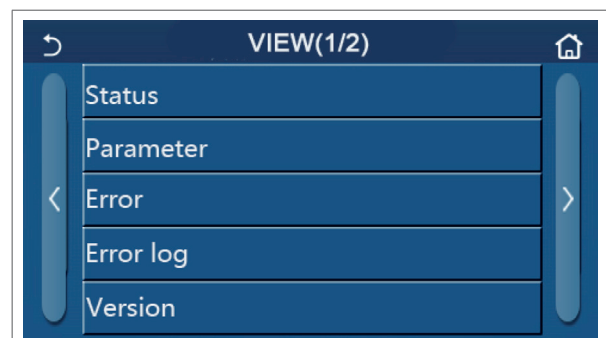

figure 37 - The View menu (language setting: Engels)

The paragraphs below provide an explanation of each topic.

7.3.8.1. Status

To view the status of various components and processes of the heat pump, proceed as follows:

1. Tap **VIEW** in the main menu.
2. Tap **Status**.
3. Tap < or > until the desired page with status displays appears on the screen.

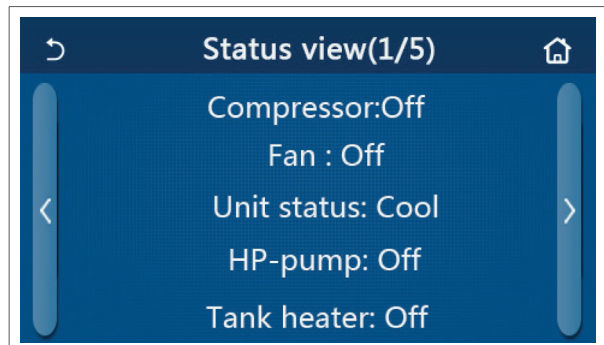

figure 38 - Status View Page (language setting: English)

The following status views are displayed in Status:

Page	Displayed Name	Full Name	Status	Remarks
1	Compressor	Status of the compressor	On/Off	-
	Fan	Status of the fan	On/Off	-
	Unit status	Status of the heat pump	Cool/ Heat/ Hot water/ Off	'Cool' is unavailable to the heating only unit.
	HP-pump	Status of the HP-pump	On/Off	-
	Tank heater	Status of the water tank heater	NA	-
2	3-way valve 1	Status of the 3-way valve 1	NA	-
	3-way valve 2	Status of the 3-way valve 2	On/Off	-
	Crankc. heater	Status of the compressor crankcase heater	On/Off	-
	HP-heater 1	Status of the heater 1 for the heat pump	On/Off	-
	HP-heater 2	Status of the heater 2 for the heat pump	On/Off	-
3	Chassis heater	Status of the base plate element	On/Off	-
	Heat exchanger	Status of the heat exchanger heater	On/Off	-
	Defrost	Status of the system defrosting	On/Off	-
	Oil return	Status of the system oil return	On/Off	-
	Thermostat	Status of the thermostat	NA	-
4	Other thermal	Status of other thermal source	NA	-
	2-way valve	Status of the 2-way valve	On/Off	-
	HP-Antifree	Status of antifreeze	On/Off	-
	Gate-Ctrl.	Status of the card	NA	-
	4-way valve	Status of the 4-way valve	On/Off	-
5	Disinfection	Status of disinfection	NA	-
	Flow switch	Status of the flow switch	On/Off	-
	Tank pump	Status of the tank pump	NA	-

7.3.8.2. Parameter

To view the various parameters of the heat pump, proceed as follows:

1. Tap **VIEW** in the main menu.
2. Tap **Parameter**.
3. Tap < or > until the desired page with parameter views is displayed on the screen.

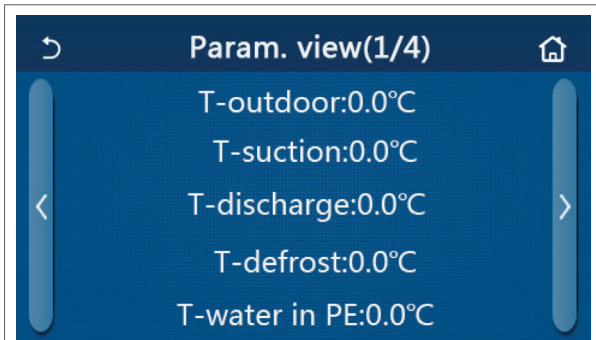

figure 39 - Parameter View Page (language setting: English)

The following parameter views are displayed in Parameter:

Page	Displayed Name	Full Name	Remarks
1	T-outdoor	Environmental temperature	-
	T-suction	Suction temperature	-
	T-discharge	Discharge temperature	-
	T-defrost	Defrosting temperature	-
	T-water in PE	Temperature of the heat pump's incoming water	-
2	T-water out PE	Temperature of the water leaving the heat pump	-
	T-optimal water Sen.	Leaving water temperature of the auxiliary heater	NA
	T-tank ctrl.	Water tank temperature	NA
	T-economizer in	Economizer Inlet temperature	-
	T-economizer out	Economizer outlet temperature	-
3	T-floor debug	Debugging the target temperature for underfloor heating	NA
	Debug time	Underfloor heating debug runtime	NA
	T-gas pipe	Refrigerant pipe temperature (gas)	-
	T-liquid pipe	Refrigerant pipe temperature (liquid)	-
	T-weather depend	Weather-dependent target temperature	NA
4	T-remote room	Remote room temperature	NA
	Dis. Pressure	Discharge pressure	-

7.3.8.3. Errors

The control panel can display errors in real time. In the 'Errors' overview of all errors on the main unit is visible. To view this overview, proceed as follows:

1. Tap **VIEW** in the main menu.
2. Tap **Error**.
3. Tap < or > until the desired page with error displays appears on the screen.

Note: Each page displays a maximum of 5 errors.

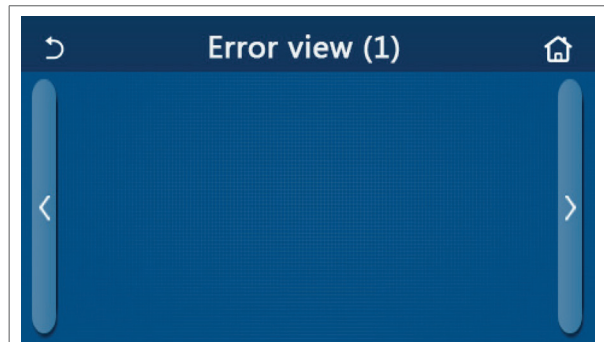

figure 40 - Error View Page (language setting: English)

The following error messages may be displayed in Error:

No.	Full Name	Displayed Name
1	Ambient temperature sensor error	Ambient sensor
2	Defrosting temperature sensor error	Defrost sensor
3	Discharge temperature sensor error	Discharge sensor
4	Suction temperature sensor error	Suction sensor
5	Economizer inlet temperature sensor	Econ. in sens.
6	Economizer outlet temperature sensor	Econ. out sens.
7	Fan error	Outdoor fan
8	High pressure protection	High pressure
9	Low pressure protection	Low pressure
10	High discharge protection	Hi-discharge
11	Capacity DIP switch error	Capacity DIP
12	Communication error between the outdoor and indoor main boards	ODU-IDU Com.
13	Communication error between the outdoor main board and the drive board	Drive-main com.
14	Communication error between the display panel and indoor main board	IDU Com.
15	High pressure sensor error	HI-pre. sens.
16	Leaving water temperature sensor error for the plate type heat exchanger of the heat pump	Temp-HELW
17	Leaving water temperature sensor error for the auxiliary electric heat of the heat pump	Temp-AHLW

No.	Full Name	Displayed Name
18	Entering water temperature sensor error of the plate type heat exchanger of the heat pump	Temp-HEEW
19	Water tank temperature sensor error ("NA" for mini chillers)	Tank sens.
20	Remote room temperature sensor error	T-Remote Air
21	Protection for the flow switch of the heat pump	HP-Water Switch
22	Welding protection to the auxiliary electric heater 1 of the heat pump	Auxi. heater 1
23	Welding protection to the auxiliary electric heater 2 of the heat pump	Auxi. heater 2
24	Welding protection to the water tank electric heater	Auxi. -WTH
25	DC bus under-voltage or voltage drop error	DC under-vol.
26	DC bus over-voltage DC	over-vol.
27	AC Current Protection (Input Side)	AC curr. pro.
28	IPM defective	IPM defective
29	PFC defective	PFC defective
30	Device does not start up	Start failure
31	Phase Loss	Phase Loss
32	Jumper cap error	Jumper cap error
33	Driver resetting	Driver reset
34	Compressor overcurrent	Com. over-cur.
35	Overspeed	Overspeed
36	Current sensing circuit error or current sensor error	Current sen.
37	Desynchronization	Desynchronize
38	Compressor Stalling	Comp. stalling
39	Radiator or IPM or PFC over-temperature	Overtemp.-mod.
40	Radiator or IPM or PFC temperature sensor error	T-mod. sensor
41	Charging circuit error	Charge circuit
42	AC Input Voltage Error	AC voltage
43	Ambient temperature sensor error at the drive board	Temp-driver
44	AC contactor protection or input over-zero error	AC contactor
45	Temperature drift protection	Temp. drift
46	Sensor connection protection (the current sensor fails to be connected with the corresponding phase U and or phase V)	Sensor con.
47	Communication error between the display panel and the outdoor unit	ODU Com.
48	Refrigerant vapor line temperature sensor error	Temp RGL
49	Refrigerant liquid line temperature sensor error	Temp RLL
50	4-way valve error 4-way valve	4 way valve

7.3.8.4. Error log

The error log shows the name and time of each error that has occurred.

To view the error log, proceed as follows:

1. Tap **VIEW** in the main menu.
2. Tap **Error log**.
3. Tap < or > until the desired page with error displays appears on the screen.

Note: If the number of errors in the error log exceeds 20, the oldest error is automatically replaced by the most recent one.

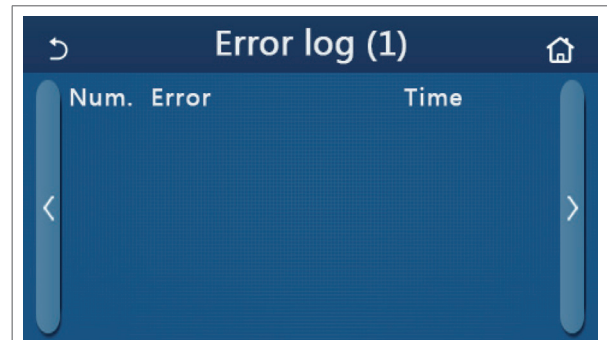

figure 41 - Page Error Log (language setting: English)

7.3.8.5. Version

1. Tap **VIEW** in the main menu.
2. Tap **Version**.

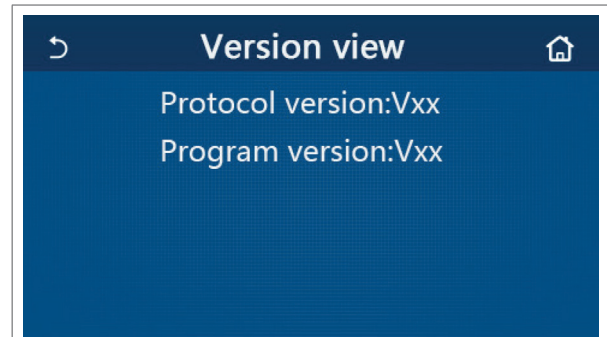

figure 42 - Page Version (language setting: English)

8. Daily usage and maintenance

8.1. General maintenance

- To prevent damage to the device, all safety components are adjusted and sealed. Do not modify or remove them.
- During the initial start-up of the device or after a long period of inactivity (more than 1 day) with the power cut off, it is necessary to preheat the device by applying power for at least 8 hours.
- Never place objects on the device and its accessories. Keep the area around the device dry, clean, and well-ventilated.
- Regularly remove accumulated dust from the condenser fins to ensure optimal performance and prevent the device from shutting down due to protection mechanisms.
- To prevent damage or blockage of the water system, clean the filter in the water system periodically and regularly check the water pressure.
- To ensure protection against freezing, do not turn off the power if the ambient temperature in winter drops below freezing.
- To prevent frost damage to the device, drain the water in the device and the piping system that is not used for an extended period.
- During device operation, avoid frequently closing any manually operated ball valves in the water system.
- Regularly check the operation of each component to ensure there are no oil stains at pipe connections and filling openings, preventing refrigerant leakage.
- If there is a malfunction beyond the control of the users, quickly contact the authorized service center.

Note: The water pressure indicator is installed in the return line of the device.

1. If the pressure is less than 0.5 bar, immediately add water.
2. When refilling, the pressure in the hydraulic system should not exceed 2.5 bar.

8.2. Important for usage in the winter

1. Check that the air inlets and outlets of the indoor and outdoor units are not blocked.

2. Verify that the grounding connection is reliable.
3. If the unit has been out of operation for an extended period, it should be powered on for 8 hours before starting normal operation to preheat the compressor.
4. Winter frost protection precautions: During temperatures below freezing in winter:
 - a. Antifreeze liquid should be added to the water system, and external water pipes should be properly insulated. Glycol liquid is recommended as an antifreeze agent.
 - b. Anti-freeze valves should be installed in the water pipes connected to the heat pump.

8.3. Regaining refrigerant

When removing refrigerant from a system, both for maintenance and decommissioning purposes, it is recommended to safely remove all refrigerants.

When transferring refrigerant into cylinders, ensure that only suitable refrigerant recovery cylinders are used. Make sure the correct number of cylinders is available to hold the total system charge. All cylinders to be used should be designated for the recovered refrigerant and labeled for that specific refrigerant (e.g., dedicated cylinders for refrigerant recovery). Cylinders should be equipped with pressure relief valves and appropriate shut-off valves that function properly.

Empty recovery cylinders should be evacuated and, if possible, cooled before the recovery process takes place.

The recovery equipment should be in good condition and come with a set of instructions related to the equipment being used, suitable for recovering flammable refrigerants. Additionally, a set of calibrated weighing scales should be available and in good condition.

Hoses should be complete with leak-free disconnect couplings and be in good condition. Before using the recovery machine, check that it is functioning properly, well-maintained, and that any associated electrical components are sealed to prevent ignition in case of refrigerant release. Consult the manufacturer if in doubt.

The recovered refrigerant should be returned to the refrigerant supplier in the appropriate recovery cylinder,

and the relevant waste transfer documentation should be arranged. Do not mix refrigerants in recovery equipment, especially not in cylinders.

If compressors or compressor oil are being removed, ensure they are collected to an acceptable level to ensure no flammable refrigerant remains in the lubricating oil. Collection should be carried out before returning the compressor to suppliers. Only electric heating of the compressor body may be used to speed up this process. When draining oil from a system, it should be done safely.

8.4. Putting out of operation

Before performing this procedure, it is essential for the technician to be fully familiar with the equipment and all its details. It is recommended to safely recover all refrigerants. Before starting the task, a sample of oil and refrigerant should be taken in case analysis is needed before reusing the recovered refrigerant. It is essential to have electricity available before starting the task.

1. Familiarize yourself with the equipment and its operation.
2. Electrically isolate the system.
3. Ensure that before performing the procedure: mechanical tools are available, if needed, for handling refrigerant cylinders; all personal protective equipment is available and correctly used; the recovery process is supervised by a qualified person at all times; recovery equipment and cylinders comply with the appropriate standards.
4. Drain the refrigerant system, if possible.
5. If a vacuum is not possible, create a manifold so that refrigerant can be removed from different parts of the system.
6. Ensure the cylinder is placed on the weighing scale before recovery takes place.
7. Start the recovery machine and operate it according to the manufacturer's instructions.
8. Do not overfill the cylinders. (Not more than 80% of the liquid volume).
9. Do not exceed the maximum working pressure of the cylinder, even temporarily.
10. Once the cylinders are properly filled and the process is complete, ensure that the cylinders and equipment are promptly removed from the location and that all shut-off valves on the equipment are closed.
11. The recovered refrigerant should not be charged into another refrigeration system unless it has been cleaned and checked.

9. Malfunctions

9.1. Malfunction index

Malfunctions	Reasons	Solutions
The compressor does not start.	An issue with the power supply.	The phase sequence is reversed and needs to be repaired (swap 2 phases).
	The connection wire is loose.	Switch off, repair, and restart.
	Malfunction of the motherboard.	Find the cause and repair.
	Malfunction of the compressor.	Replace the compressor.
Heavy sound of the fan.	The locking nut of the fan is loose.	Reattach the fan locking nut.
	The fan blade is touching the edge of the grill.	Identify the cause and adjust.
	De operation of the fan is unreliable.	Replace the fan.
Heavy sound of the compressor.	Fluid clumping occurs when fluid refrigerant enters the compressor.	Verify if the expansion valve is defective and if the temperature sensor is loose. Repair if necessary.
	Internal components in the compressor are broken.	Replace the compressor.
The water pump is not functioning or abnormally.	Malfunction of the power supply.	Identify the cause and repair.
	Malfunction of the relay.	Replace the relay.
	There is air in the water pipe.	Vent the system.
The compressor starts and stops regularly.	Excessive quantity or poor quality of the refrigerant in the system.	Drain or add refrigerant.
	Poor circulation of the water system.	The water system is cluttered or it contains air. Check the water pump, valve, and water system. Clean or vent the water filter.
	Low load.	Modify the load or add extra dispensing devices.
The device does not heat while the compressor is on.	Leakage of the refrigerant.	Repair the leak and add refrigerant.
	Malfunction of the compressor.	Replace the compressor.
Bad efficiency of warm water heating.	Poor isolation of the water system.	Improve the insulation-efficiency of the system.
	Poor heat exchange of the evaporator.	Verify if the airflow through the device is at a normal level and clean the evaporator.
	The poor refrigerant in the device.	Check if there is a refrigerant leak.
	Water-side blockage of the heat exchanger.	Clean or replace the heat exchanger.
Malfunction: error code ODU com./IDU com	HPX30A only: phase sequence incorrect (counter-clockwise rotating field instead of clockwise)	Reverse the phase sequence.
	Connection between control unit and terminal strip interrupted	Check and repair the connection between the control unit and the terminal strip.
	Terminals a and b between control and terminal strip reversed.	Reverse terminals a and b between the control unit and the terminal strip.

9.2. Error code list

Note: the codes are visible on the display on the control board, see figure 50.

Errors of the complete outdoor unit			
Code-indication	Error name	Origin of error	Description of the control element
F4	Error of the outdoor temperature sensor	The plug of the temperature sensor is not correctly connected to the contact of the motherboard.	It will be automatically cleared after the defect has been resolved.
		The resistance of the temperature sensor is incorrect.	
d6	#alleenNL#	The plug of the temperature sensor is not correctly connected to the contact of the motherboard.	It will be automatically cleared after the defect has been resolved.
		The resistance of the temperature sensor is incorrect.	

Errors of the complete outdoor unit			
Code-indication	Error name	Origin of error	Description of the control element
F7	Outlet temperature sensor error	The plug of the temperature sensor is not correctly connected to the motherboard.	It will be automatically cleared after the defect has been resolved.
		The resistance of the temperature sensor is incorrect.	
F5	Inlet temperature sensor error	The plug of the temperature sensor is not correctly connected to the contact of the motherboard.	It will be automatically cleared after the defect has been resolved.
		The resistance of the temperature sensor is incorrect.	
EF	Fan error	The motherboard of the outdoor unit is damaged.	If it occurs 6 times within an hour, it can be cleared by restarting. If it occurs less than 6 times, it will be automatically cleared.
		The wire connecting the wiring terminals to the motherboard is broken.	
E1	Compressor high-pressure protection	Compressor high-pressure switch is broken or the wiring is loose.	Start the unit again. If the error is removed, the code will be cleared.
		Insufficient water quantity in the system.	
		Incorrect installation of the tank temperature sensor.	
		The gas valve and liquid valve are not fully open.	
		The electronic expansion valve is not functioning properly.	
E3	Compressor low-pressure protection	Compressor low-pressure switch is broken or the wiring is loose.	It will be automatically cleared after the defect has been resolved.
		The system has leaked.	
		The fan is not running or running in reverse.	
E4	Compressor discharge temperature protection	The resistance of the temperature sensor is incorrect.	It will be cleared if the discharge temperature is lower than 92 °C.
		The electronic expansion valve is blocked.	
		The system has leaked.	
		The outdoor unit motherboard is damaged.	
C5	Capacity setting error	The jumper is off.	Turn off the device and restart it. If the error is deleted, the code will be cleared.
E6	Communication error (between indoor and outdoor unit)	The plug of the communication cable is not correctly connected to the contact of the motherboard.	It will be restored as soon as the communication is restored or it will be displayed the whole time.
		The communication cable is defect.	
		The communication cable is not correctly connected.	
		The shield of the communication cable is not connected on the side of the heat pump.	
		The outdoor unit is not powered.	
E6	Communication error (between outside mother board and controller inside)	The plug of the communication cable is not correctly connected to the contact of the motherboard.	It will be restored as soon as the communication is restored or it will be displayed the whole time.
		The communication cable is defect.	
		The communication cable is not correctly connected.	
		The shield of the communication cable is not connected on the side of the heat pump.	
		The outdoor unit is not powered.	
Fc	High-pressure switch error	The sensor is damaged.	It will be automatically cleared after the defect has been resolved.
		The wire of the sensor is loose.	
		Sensor position is wrong.	
F9	Outlet temperature sensor error	The plug of the temperature sensor is not correctly connected to the contact on the motherboard.	It will be automatically cleared after the defect has been resolved.
		The resistance of the temperature sensor is incorrect.	
dH	Backup Outlet temperature sensor error	The plug of the temperature sensor is not correctly connected to the contact on the motherboard.	It will be automatically cleared after the defect has been resolved.
		The resistance of the temperature sensor is incorrect.	

Errors of the complete outdoor unit			
Code-indication	Error name	Origin of error	Description of the control element
F1	Liquid line temperature sensor error	The plug of the temperature sensor is not correctly connected to the contact on the motherboard.	It will be automatically cleared after the defect has been resolved.
		The resistance of the temperature sensor is incorrect.	
FE	First sanitary (potable) water tank temperature sensor error	The plug of the temperature sensor is not correctly connected to the contact on the motherboard.	It will be automatically cleared after the defect has been resolved.
		The resistance of the temperature sensor is incorrect.	
F3	Gas line temperature sensor error	The plug of the temperature sensor is not correctly connected to the contact on the motherboard.	It will be automatically cleared after the defect has been resolved.
		The resistance of the temperature sensor is incorrect.	
F0	External air temperature sensor error	The plug of the temperature sensor is not correctly connected to the contact on the motherboard.	It will be automatically cleared after the defect has been resolved.
		The resistance of the temperature sensor is incorrect.	
Ec	Water flow switch error	The switch is damaged.	It will be restored after the unit is turned off.
		The wiring of the switch is loose.	
		The position of the switch is wrong.	
E2	Indoor antifreeze protection	The resistance of the temperature sensor is incorrect.	
		The electronic expansion valve is not functioning normally.	
Ed	Outdoor temperature MAX protection	The resistance of the temperature sensor is incorrect.	Start the unit again. If the error is removed, the code will be cleared.
		The plug of the temperature sensor is not correctly connected to the contact on the motherboard.	
		The motherboard of the outdoor unit is damaged.	
EH	Malfunction of the first internal connection of the electric heating	The alternating current relay is defective.	Start the unit again. If the error is removed, the code will be cleared.
EH	Error of the second electrical heating element	The alternating current relay is defective.	Start the unit again. If the error is removed, the code will be cleared.
EH	Error electrical element sanitary (potable) water	The alternating current relay is defective.	Start the unit again. If the error is removed, the code will be cleared.

Errors of the inverter				
Function		Display on segment display of the device	Display on the wired controller	Others
Inverter Driver Error	Reset of the drive system	P0	Reset of the drive system	-
	Startup error of the compressor	Lc	Startup error of the compressor	-
	Phase protection	Ld	Phase protection	-
	Power protection of the compressor	P5	Power protection of the compressor	-
	Communication error	P6	Communication error	-
	Sensor error of the heat sink	P7	Sensor error of the heat sink	-
	Protection against overheating heat sink	P8	Protection against overheating heat sink	-
	AC-power protection (input side)	PA	AC-power protection (input side)	-
	Current sensor error	Pc	Current sensor error	-
	Connection protector of the sensor	Pd	Connection protector of the sensor	-
	Overvoltage protection	PH	Overvoltage protection	-
	Undervoltage protection	PL	Undervoltage protection	-
	Abnormality of the power supply voltage	PP	Abnormality of the power supply voltage	-
	Error in charging circuit	PU	Error in charging circuit	-
	IPM-protection	H5	IPM-protection	-
	Desynchronising the motor	H7	Desynchronising the motor	-
PFC-deviation	Hc	PFC-deviation	-	

9.3. Flow chart troubleshooting

9.3.1. Compressor high-pressure protection E1

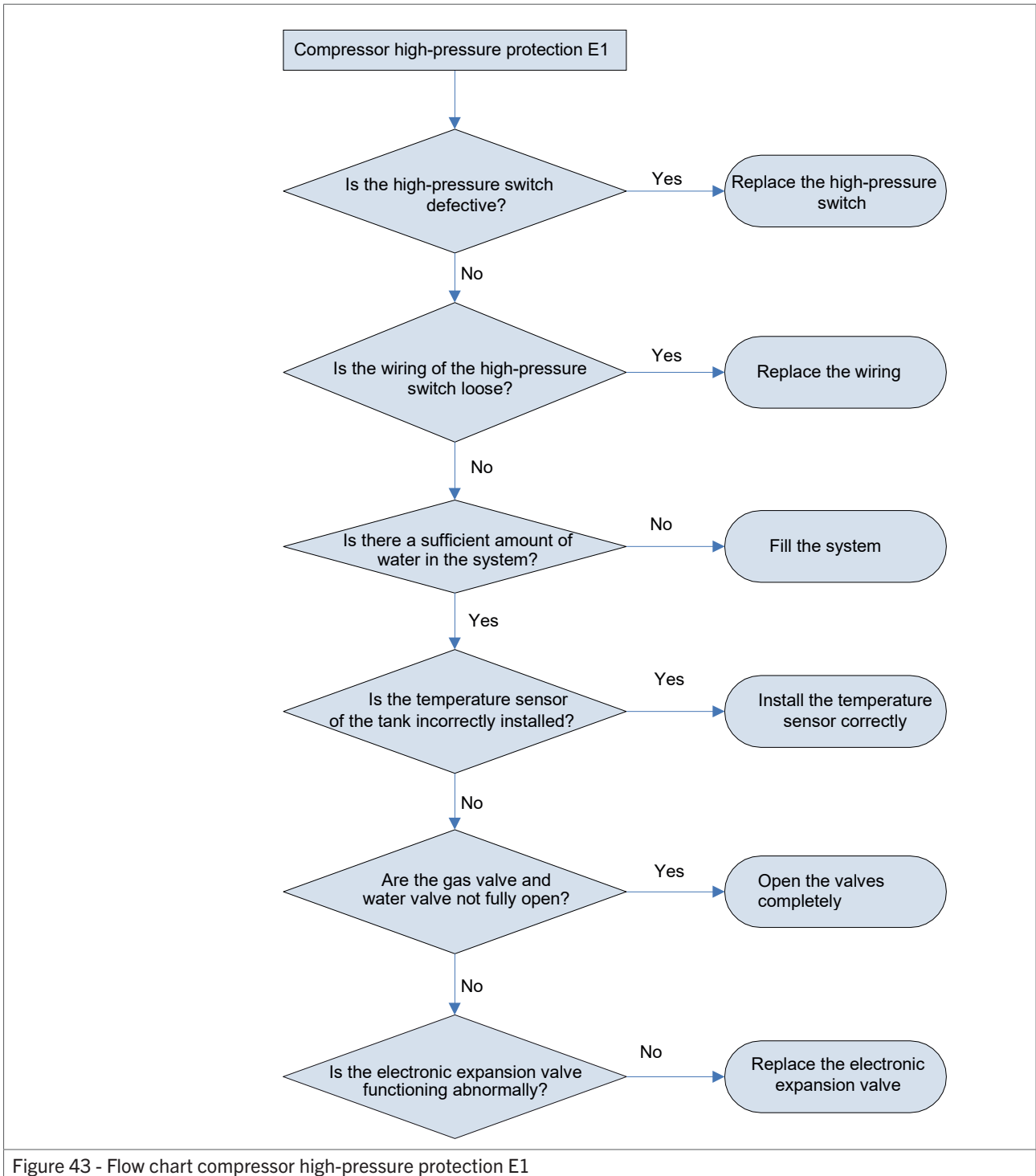

Figure 43 - Flow chart compressor high-pressure protection E1

9.3.2. Compressor Low-pressure protection E3

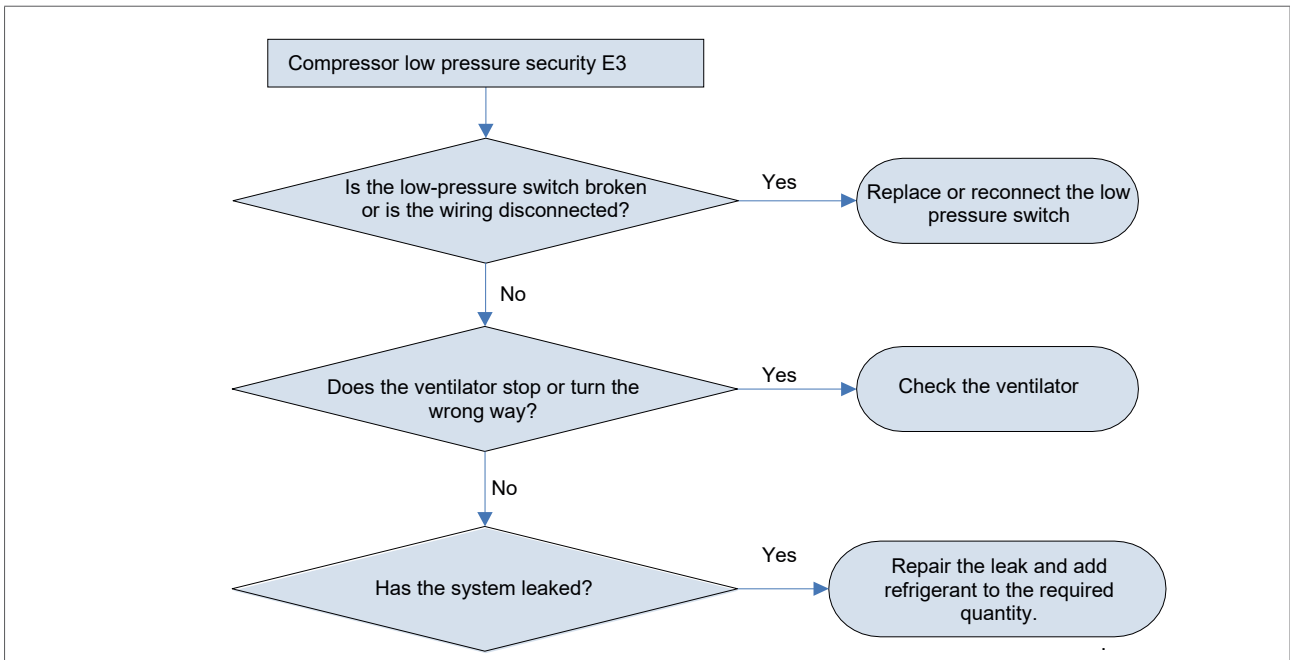

Figure 44 - Flow chart compressor Low-pressure protection E3

9.3.3. Compressor discharge temperature protection E4

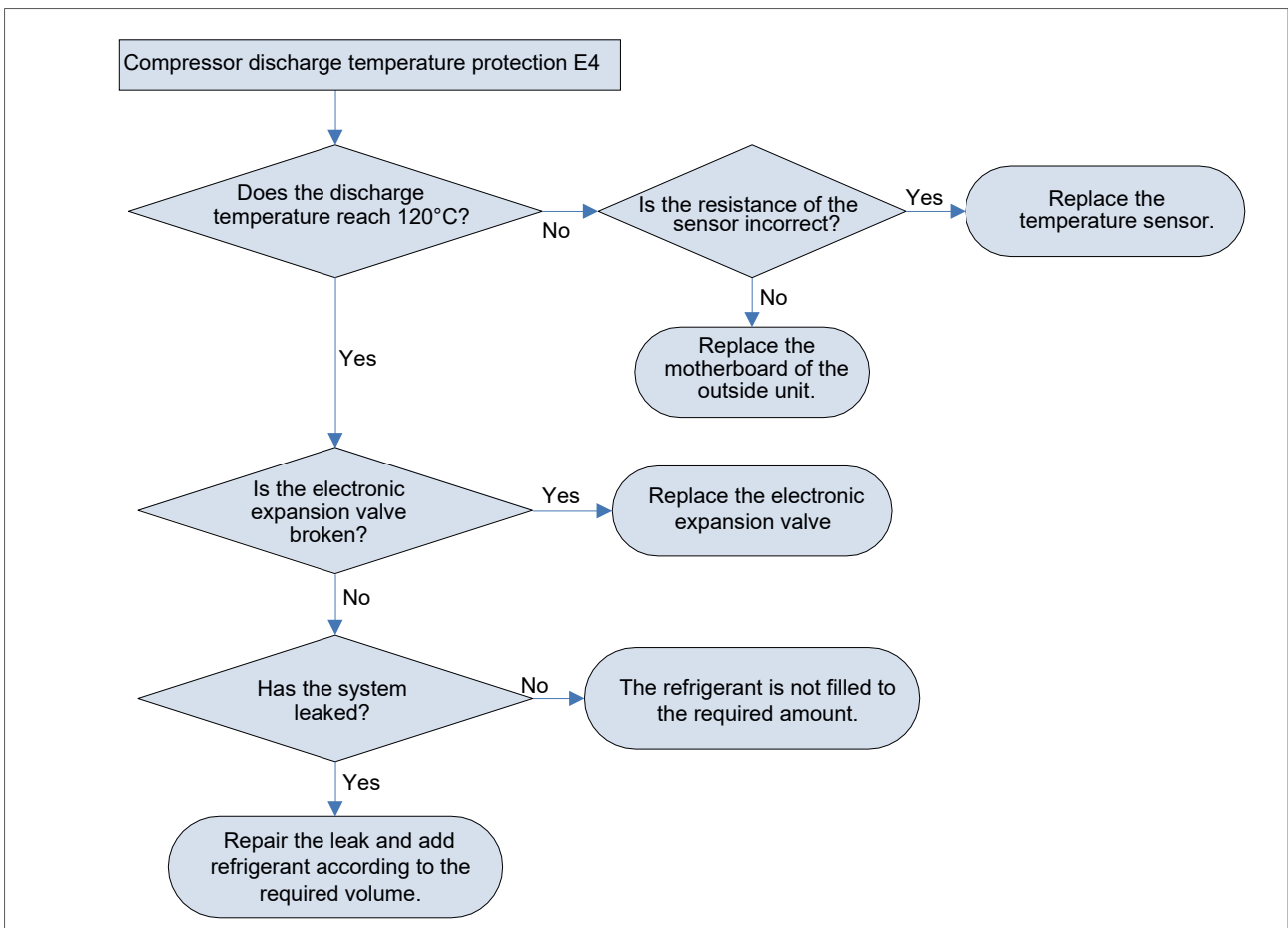

Figure 45 - Flow chart compressor discharge temperature protection E4

9.3.4. Error outside ventilator EH

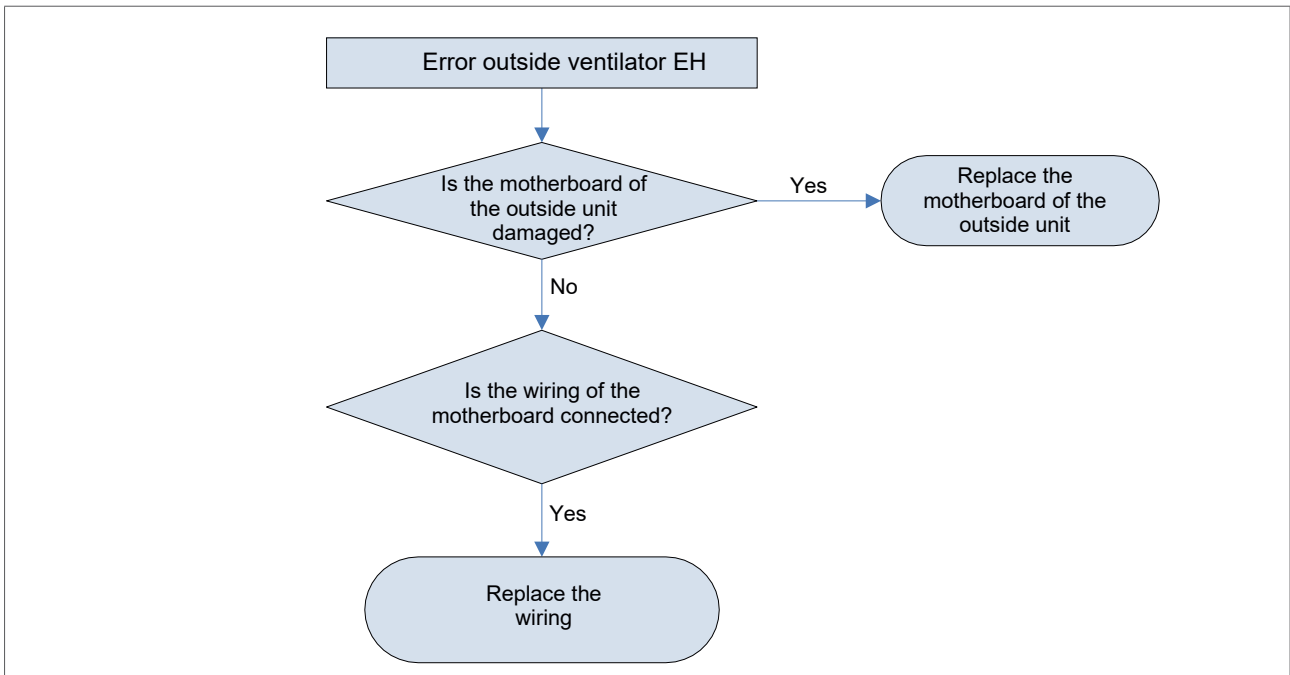

Figure 46 - Flow chart error outside ventilator EH

9.3.5. Temperature sensor error

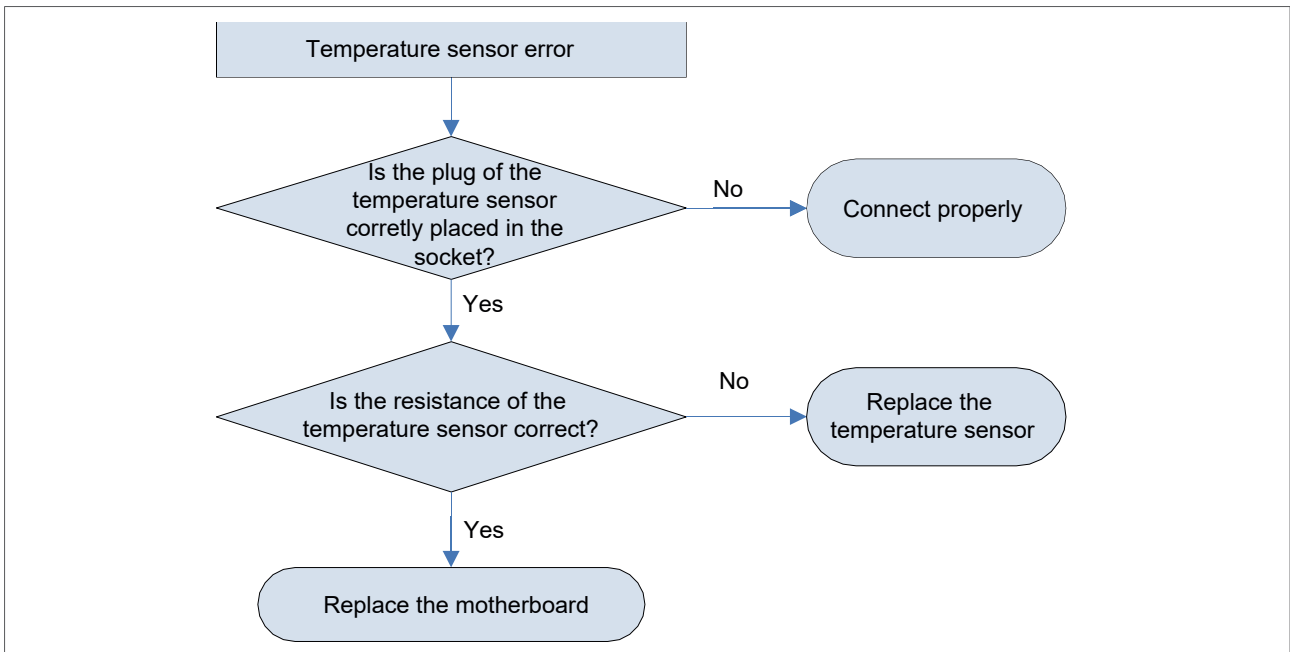

Figure 47 - Flow chart temperature sensor error

9.3.6. Communication error E6

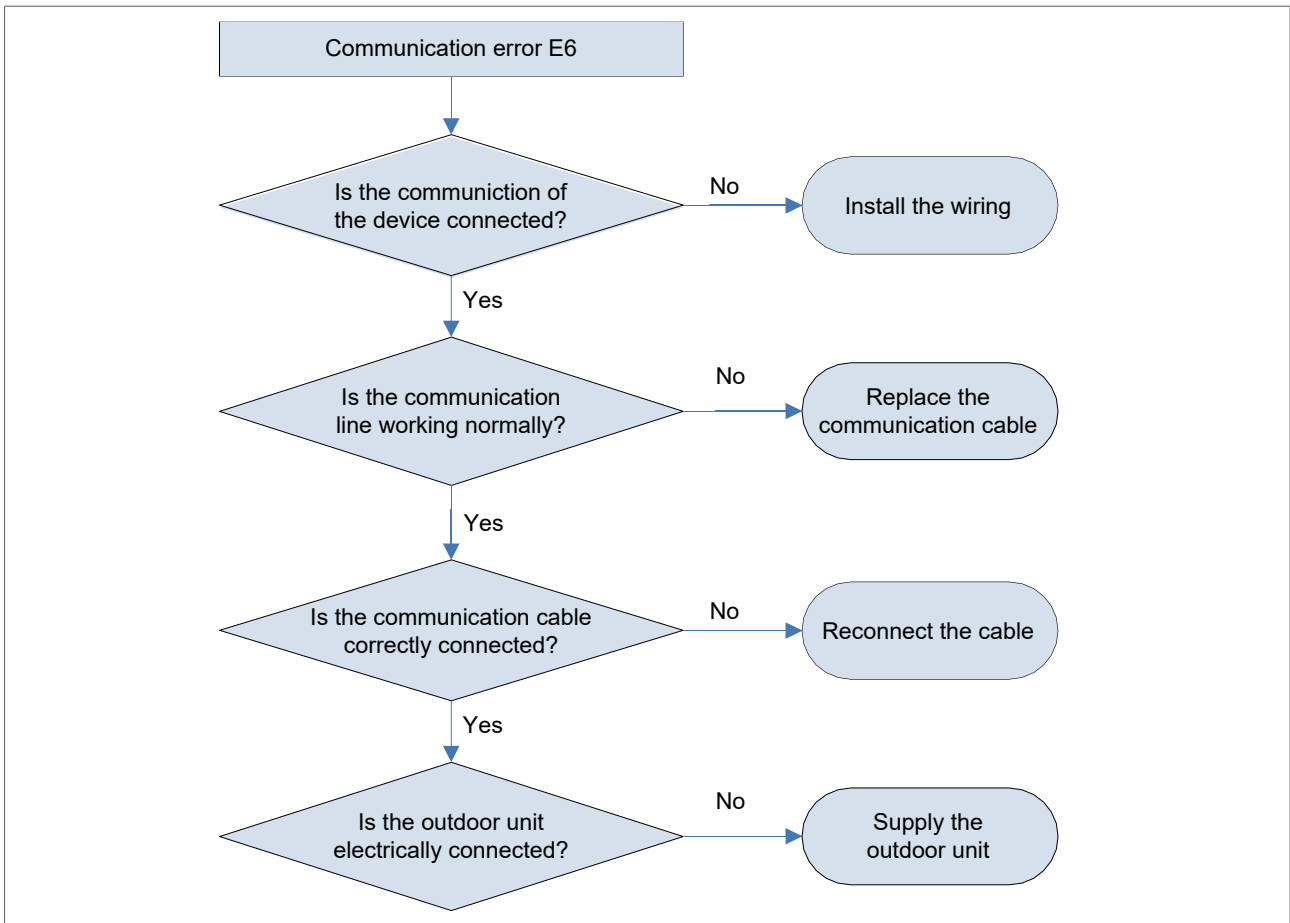

Figure 48 - Flow chart communication error E6

9.4. Diagnosis of the PCB

- **DC Overvoltage:** It is detected that the direct current voltage exceeds 420V after activation. If the protection occurs 6 times within an hour, it cannot be resumed unless it is deactivated and reactivated.
- **Under voltage:** It is detected that the supply voltage is below 200V after device startup. If the protection occurs 6 times within an hour, it cannot be resumed unless it is deactivated and reactivated.
- **PFC Deviation:** Protection against PFC deviations is detected after PFC has been operating for 10 seconds. If the protection occurs 6 times within an hour, it cannot be resumed unless it is deactivated and reactivated.
- **IPM Drive Line Protection:** Protection against IPM deviations is detected after IPM has been operating for 10 seconds. If the protection occurs 6 times within an hour, it cannot be resumed unless it is deactivated and reactivated.
- **Compressor Overcurrent Protection:** Protection occurs when the instantaneous current is detected above 45A. If the protection occurs 6 times within an hour, it cannot be resumed unless it is

deactivated and reactivated.

- **IPM Drive Plate Overheating Protection:** Protection occurs when the internal temperature of the IPM exceeds 105°C. If the protection occurs 6 times within an hour, it cannot be resumed unless it is restarted.
- **Abnormal Cooling Fin Sensor Value:** Protection occurs when there is a break or short circuit in the temperature sensor on top of the IPM module. If the protection occurs 6 times within an hour, it cannot be resumed unless it is deactivated and reactivated.
- **Communication Error between Conversion Driver and Main Control:** The drive board cannot communicate with the main board. This error can be automatically resolved.

10. Electrical wiring diagram

10.1. Control board HPX06A / HPX12A / HPX16A



Figure 49 - Control board HPX06A / HPX12A / HPX16A

PCB imprint	Introduction
AC-L	Live power wire
N	Neutral power wire
X3	To ground
X20	E-heating of the water tank
X21	E-heater 1
X22	E-heater 2
X23	Other heating by 230VAC
X24	External water pump
X25	Reserved
X26	Reserved
X27	2-way valve 1 is normally open
X28	2-way valve 1 is normally closed
X29	Water pump of the water reservoir
X30	Reserved
X31	External 3-way valve 1
X32	Reserved
X33	Electrical three-way valve 2 open
X34	Electrical three-way valve 2 closed
CN18	Built-in water pump signal (PWM)
CN19	Backup water pump signal (PWM) -field supply

PCB imprint	Introduction
CN15	20K temperature sensor (inlet water)
CN15	20K temperature sensor (outlet water)
CN15	20K temperature sensor (liquid refrigerant line)
CN16	20K temperature sensor (refrigerant vapor line)
CN16	10K temperature sensor (outgoing temperature optional electrical heater)
CN16	Reserved
CN8	External air temperature sensor error
CN9	Water tank temperature sensor
CN7	Reserved
CN6	Reserved
CN5	Reserved
CN20	Thermostat
CN21	Safety for optional electric heating 1
CN22	Safety for optional electric heating 2
CN23	Safety for the electric heater of the water tank
CN24	Gate control detection
CN25	Flow switch
CN26	Reserved
CN3	Communication with outdoor unit
CN1	Anode
CN4	Communication with the control panel

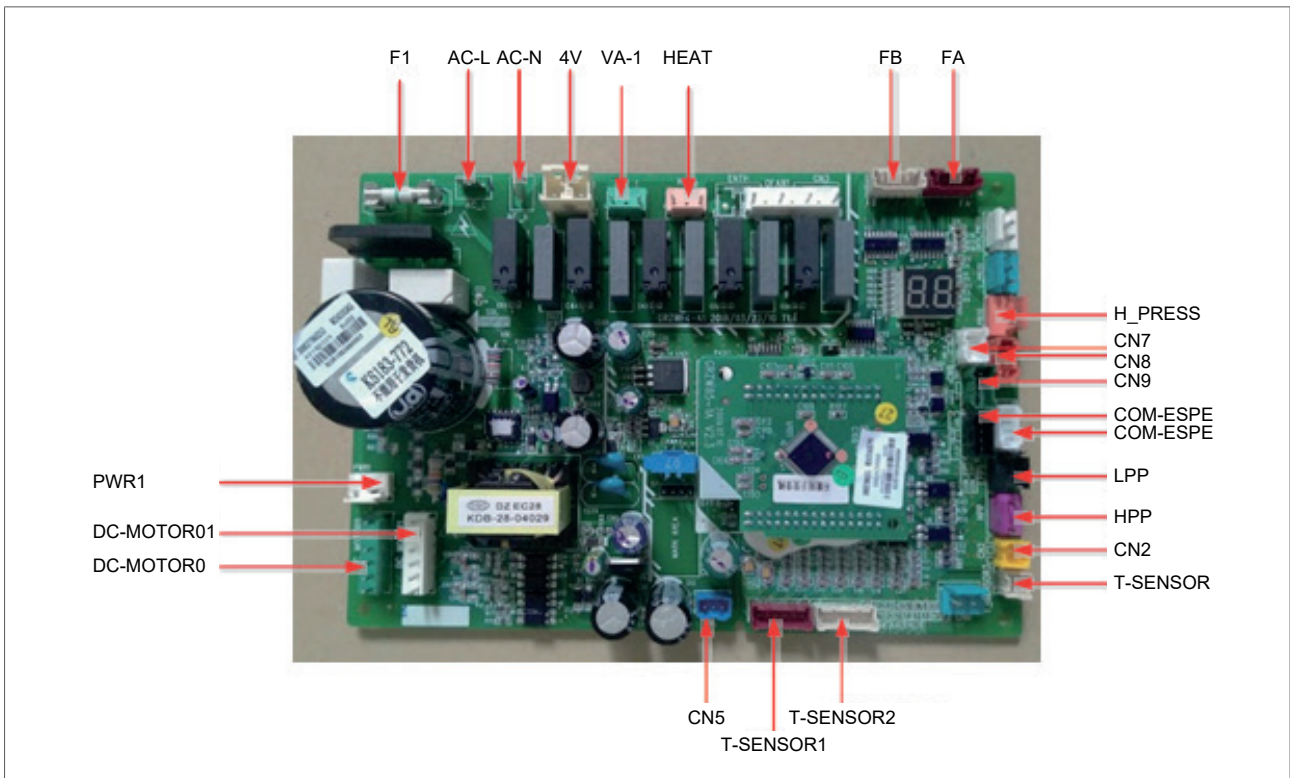

Figure 50 - Control board 2 HPX06A / HPX12A / HPX16A

PCB imprint	Introduction
AC-L	L power supply
N	Neutral wire of the power supply
PWR1	310V supply 310V direct current of the drive
F1	Fuse
4 V	4-way valve
VA-1	E-heating chassis
HEAT	Electrical heating
DC-MOTOR0	1-pins: fan supply; 3-pins: fan GND 3-pins: fan GND 4-pins: +15V 5-pins: control signal 6-pin:feedback signal
DC-MOTOR01	1-pins: fan supply; 3-pins: fan GND 3-pins: fan GND 4-pins: +15V 5-pins: control signal 6-pin:feedback signal
FA	1, 2, 3, 4 signals, supply to EXV1, electronic expansion valve, 1-4 pin: driving impulse output; 5 pin: +12V
FB	1, 2, 3, 4 signals, 5 supply to EXV2, electronic expansion valve, 1-4 pin: driving impulse output; 5 pin: +12V
T_SENSOR2	1,2: environment; 3,4: discharge; 5,6: supply
T_SENSOR1	1,2: economizer inlet; 3,4: economizer 5,6:defrosting
H_PRESS	5V signal input of the pressure sensor 1 pin: GND; 2 pin: signal input; 3 pin:+5V
HPP	1-pin: +12V, 3-pin: signal
LPP	1-pin: +12V, 3-pin: signal
CN2	1-pin: +12V, 2-pin: signal
CN7	Communication between AP1 and AP2;communication cable 2-pin: B, 3-pin: A;
CN8	1-pin: 12V, 2-pin: B, 3-pins: A, 4-pins: grounding. To the wired controller, communication cable
CN9	1-pin: +12V, 2-pin: B; 3-pole: A, 4-pole: ground
COM_ESPE1	1-pin: +3,3V, 2-pins: TXD, 3-pins: RXD, 4-pins: ground
COM_ESPE2	1-pin: +3,3V, 2-pins: TXD, 3-pins: RXD, 4-pins: ground
CN5	1-pin: ground, 2-pin: +18V, 3-pin: +15V

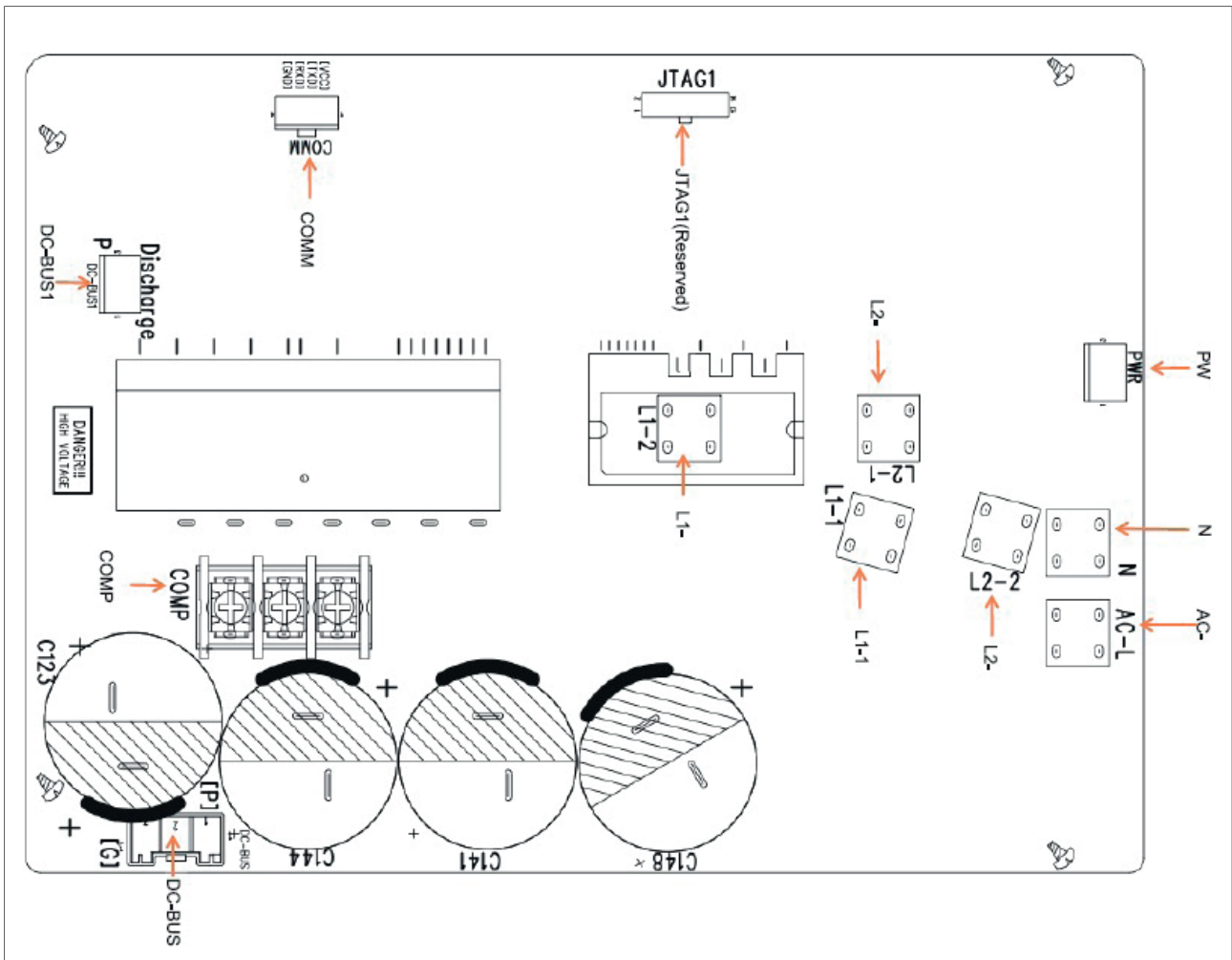

Figure 51 - Control board HPX06A

PCB imprint	Introduction
AC-L	L-OUT Live input of the filter board
N	N-OUT Neutral line input of the filter board
L1-1	To PFC inductor brown cable
L1-2	To white wire PFC-inductor
L2-1	To yellow wire PFC-inductor
L2-2	To blue wire PFC-inductor
COMP	Wiring board (3-pin)(DT-66B01W-03)(variable frequency)
COMM	Communication-interface[1-3.3V, 2-TX,3-RX, 4-GND]
DC BUS	DC-BUS-PIN for electrical discharge of the high voltage bar during the test
PWR	Power supply of the drive card [1-GND, 2-18V, 3-15V]
DC-BUS1	DC-BUS-PIN for electrical discharge of the high voltage bar during the test

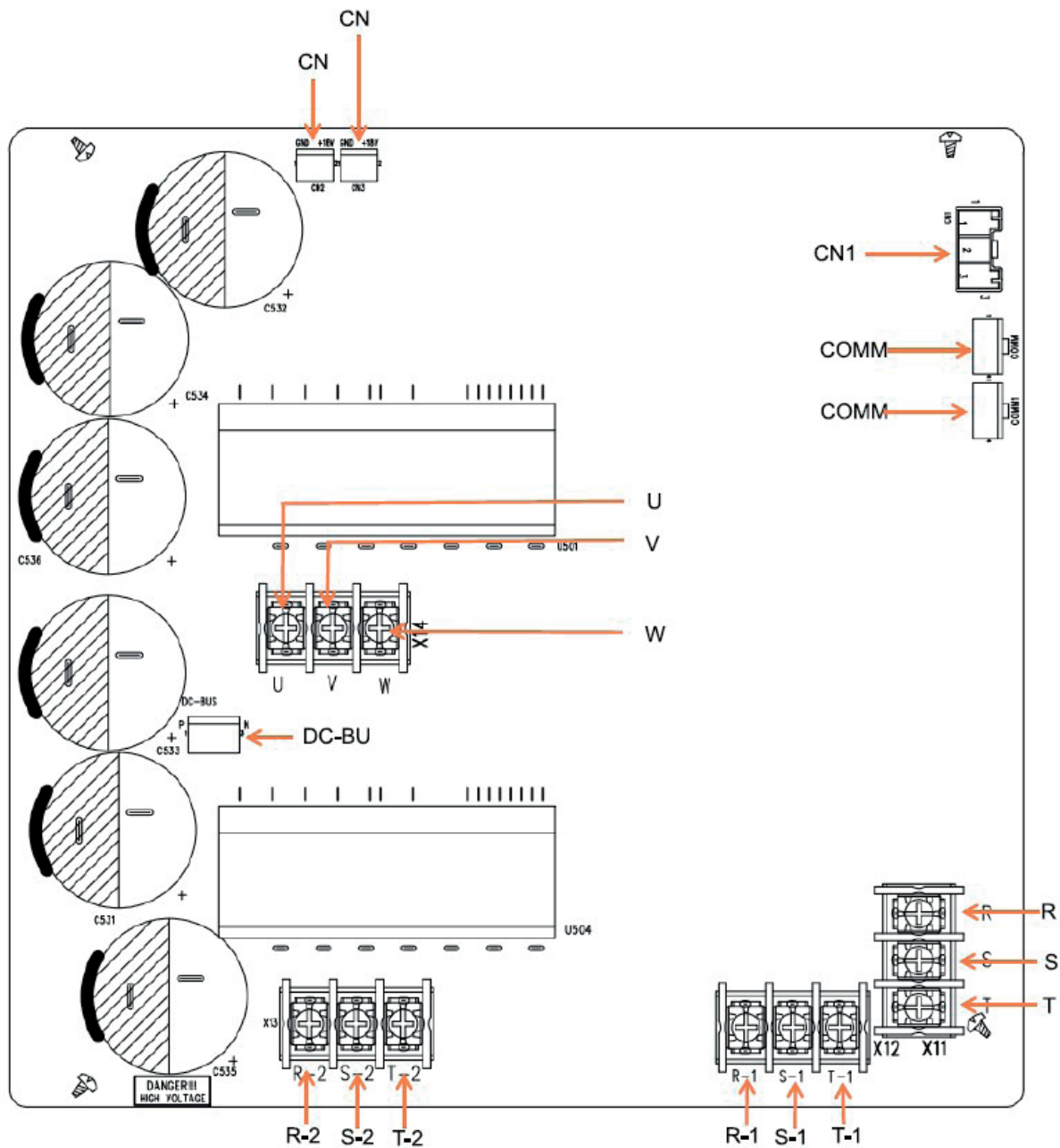

Figure 52 - Control board 3 HPX06A / HPX12A / HPX16A

PCB imprint	Introduction
W	Connection to the compressor phase-W
U	Connection to the compressor phase-U
V	Connection to the compressor phase-V
R-2	Connection to the inverter board (entrance)
S-2	
T-2	
R-1	Connection to the inverter board (entrance)
S-1	
T-1	
R	Connector to the filter L1-F
S	Connector to the filter L2-F
T	Connector to the filter L3-F
COMM1	Reserved
COMM	Communication
CN1	Switch of the power input

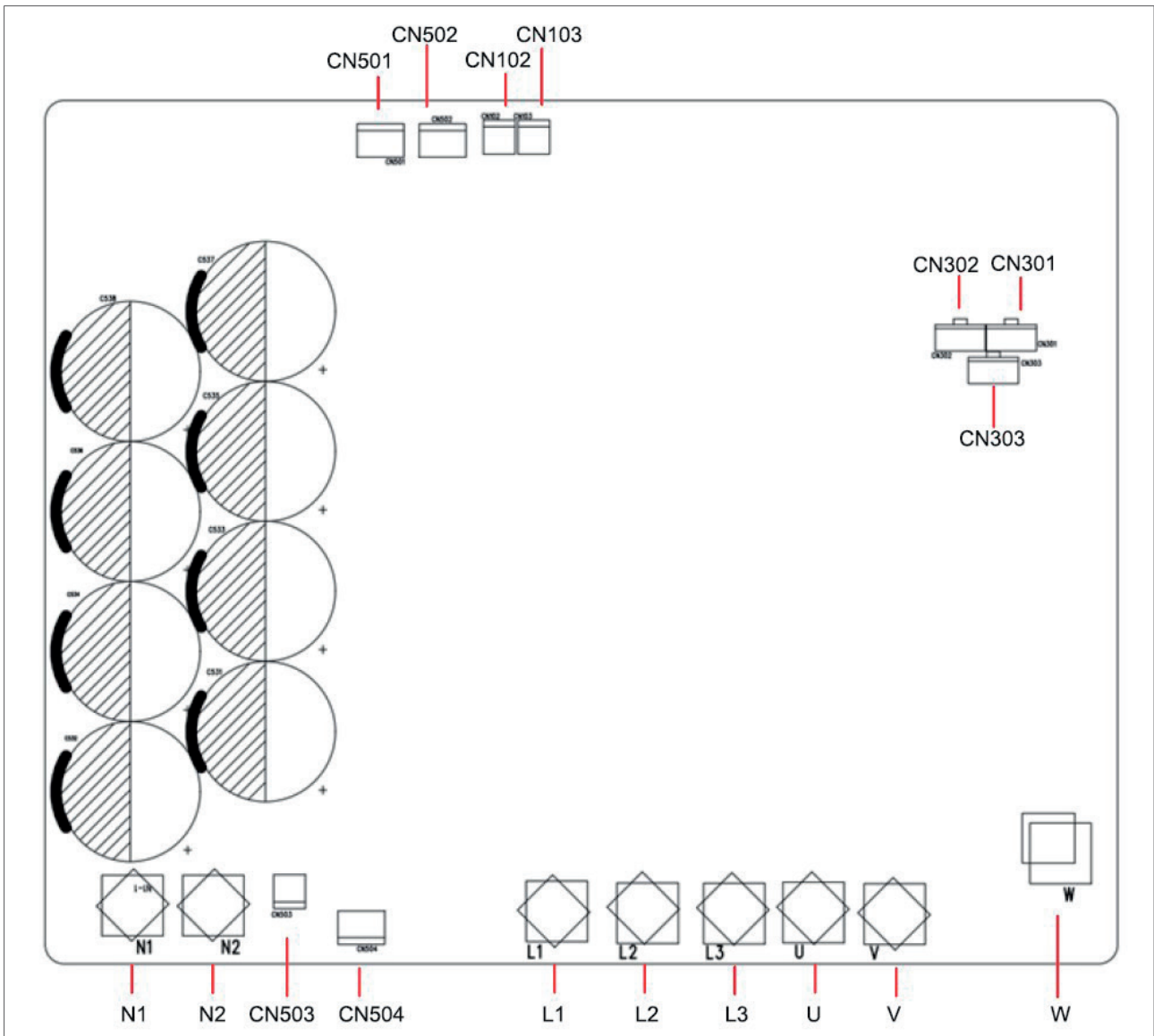

Figure 53 - Control board HPX30A

PCB imprint	Introduction
L1	Input side phase L1 of the whole unit
L2	Input side phase L2 of the whole unit
L3	Input side phase L3 of the whole unit
U	Connector to the compressor phase-U
V	Connector to the compressor phase-V
W	Connector to the compressor phase-W
N1	Connector to reactor (input)
N2	Connector to reactor (input)
CN102	Provide 18VDC voltage[1-GND,2-18V]
CN103	Provide 18VDC voltage[1-GND,2-18V]
CN301	Communication interface[1-3.3V,2-RX,3-TX,4-GND]
CN302	Communication interface[1-3.3V,2-RX,3-TX,4-GND]
CN303	Communication interface[1-3.3V,2-RX,3-TX,4-GND]
CN501	Provide DC-BUS voltage[1-N,2-P]
CN502	Provide DC-BUS voltage[1-N,2-P]
CN503	Low power consumption control[1-12V,2-GND]
CN504	No low power requirement, short circuit required

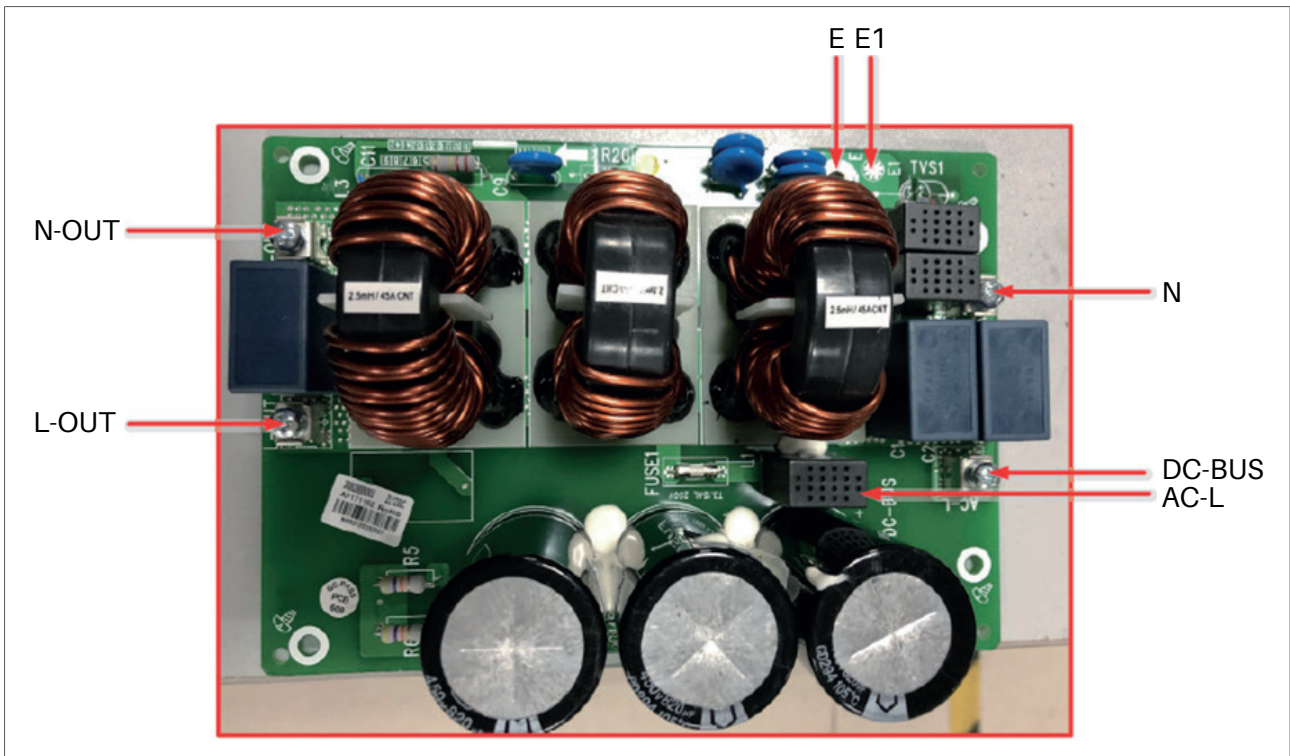

Figure 54 - Filter board 2 HPX06A

PCB imprint	Introduction
AC-L	Live supply wire of motherboard
N	Neutral supply wire of motherboard
L-OUT	Live line output of the filter board (to the drive and main boards)
N-OUT	Neutral line output of the filter board (to the drive board)
N-OUT 1	Output neutral line
L-OUT 1	Output live line
DC BUS	DC-BUS, the other end of the driving force
E	Screw hole for grounding
E1	Ground, reserved

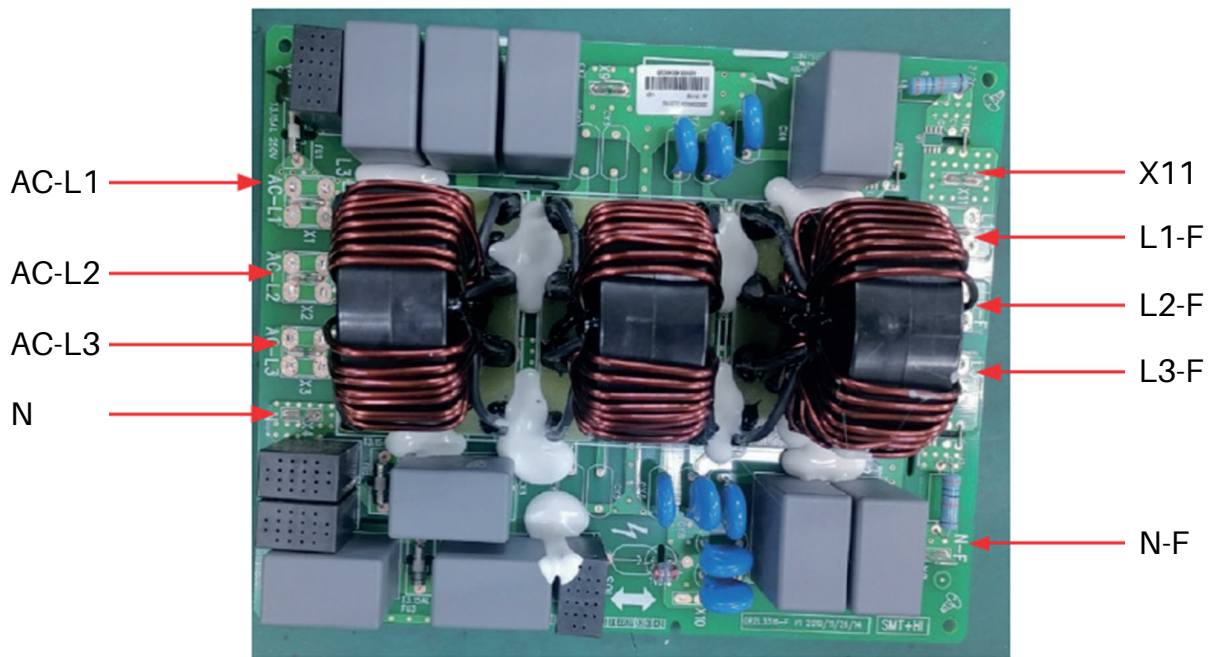

Figure 55 - Filter board HPX12A and HPX16A

PCB imprint	Introduction
AC-L1	Entrance side phase L1 of the entire unit
AC-L2	Entrance side phase L2 of the entire unit
AC-L3	Entrance side phase L3 of the entire unit
N	Entrance side neutral line of the entire unit
L1-F	Connect to the power input of the drive card
L2-F	
L3-F	
N-F	Neutral line for power supply to the main control card
X11	Live line for power supply to the main control card

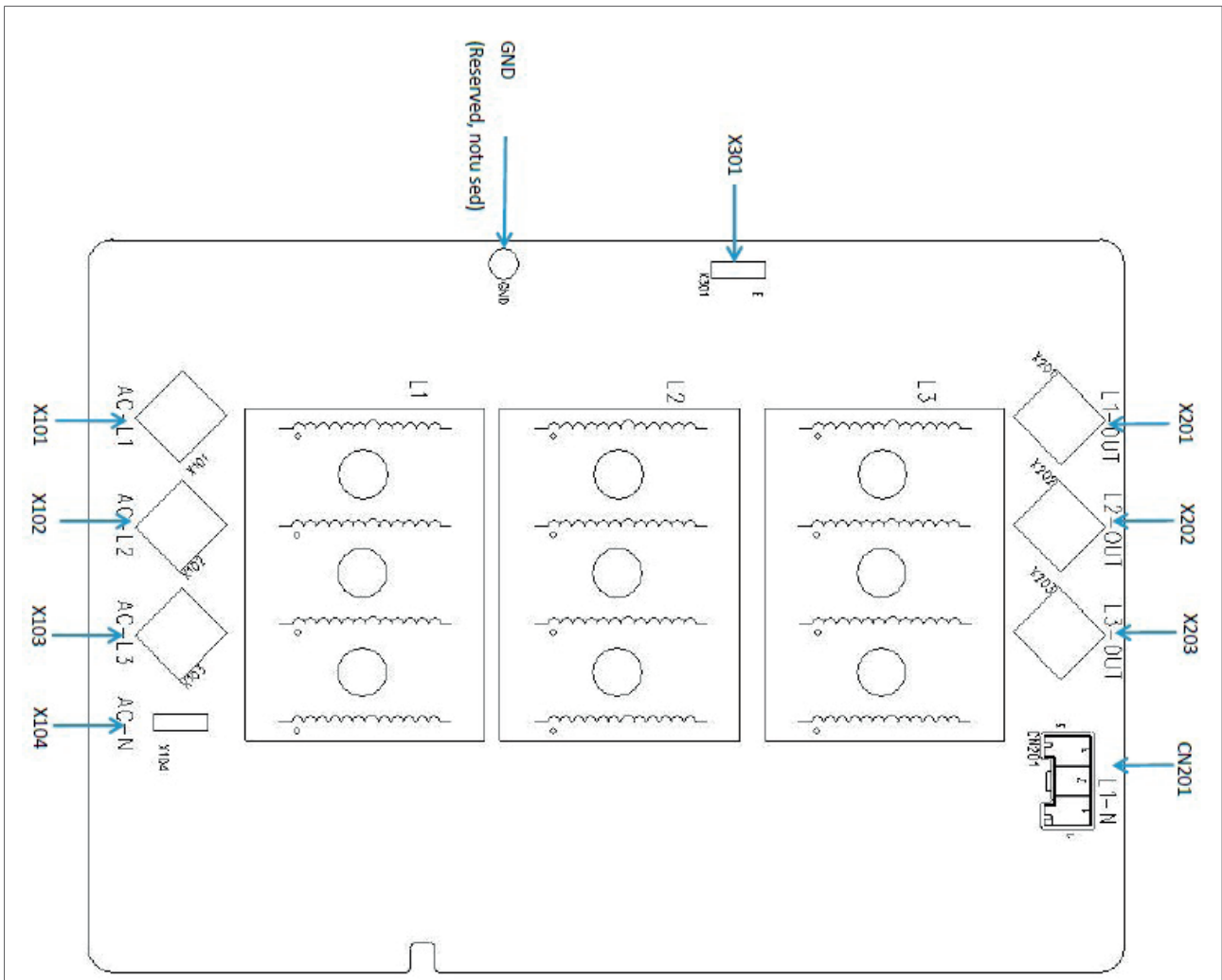

Figure 56 - Filter board HPX30A

PCB imprint	Introduction
X101	Power L1 input Interface
X102	Power L2 input Interface
X103	Power L3 input Interface
X104	Power N input Interface
X201	Power L1 input Interface
X202	Power L2 input Interface
X203	Power L3 input Interface
X301	Filter plate Earthing wire
CN201	AC 220V output, power supply to the main control board

11. Spare parts and accessories

11.1. Table of spare parts HPX

Spare part	HPX06A	HPX12-16A	HPX30A
Display	IW8024	IW8024	IW8024
Fan blade	IW8434	IW8435	IW8478
Fan grid	IW8417	IW8418	IW8479
Fan motor	IW8436	IW8437	IW8480
Top cover 6kW	-	IW8415	-
Top cover 12-16kW	-	IW8416	-
Vibration damper fan	IB6137	IB6137	IB6137
Water pump	IW8459	IW8459	IW8481

11.2. Table of accessories HPX

Accessory	HPX06A	HPX12-16A	HPX30A
Smart Controller	IW8050	IW8050	IW8050
Modbus expansion kit	GA8010	GA8010	GA8010
Power Switch 4 p, 400 V, 25 A	IK5281 (depending on model, check max. power)		
Roof duct for heat pump 100 mm	IW8032 (depending on the piping used)		
Roof duct for heat pump 140 mm	IW8031 (depending on the piping used)		
Wall support HPX06-16A	GA8650	GA8650	-
Wall support HPX30A	-	-	GA8652
Anti-frost valve 1" x 1"	IW8040	IW8040	-
Anti-frost valve 1¼" x 1¼"	IW8038	IW8038	IW8038
Anti-frost valve 1½" x 1½"	IW8039	IW8039	IW8039
Automatic venting 1"	IW8472	IW8472	-
Automatic venting 1¼"	IW8473	IW8473	-
Automatic venting 1½"	IW8474	IW8474	IW8474
Pressure meter	IW8471	IW8471	IW8471
Filter, included	IW8451	IW8451	IW8476
Filling accessory	IW8470	IW8470	-
Buffer tank (20 litres)	IW8475	IW8475	IW8475
Ball valve 1"	IW8467	IW8467	-
Ball valve 1¼"	IW8468	IW8468	-
Ball valve 1½"	IW8469	IW8469	IW8469
Rubber setup block + attachments, 2 pcs. L 600 – H 95 mm	IW8043	IW8043	-
Rubber block for extra height, 1 pc. L 600 – H 120 mm	IW8044	IW8044	-
Rubber setup block + attachments, 1 pcs. L 1000 – H 95 mm	-	-	IW8036
Rubber block for extra height, 1 pc. L 1000 – H 120 mm	-	-	IW8037

12. Disposal and recycling



This product cannot be disposed of with other household waste. It is of great importance to recycle the appliance responsibly to promote the sustainable reuse of material resources, and to prevent possible damage to the environment or human health through uncontrolled waste disposal. Make sure to use the return- and collection systems to return the product, or contact the installer where the product has been purchased. They can recycle this product in an environmentally friendly manner.

13. Declaration of conformity

Winterwarm Heating Solutions B.V.
 Olden Goorweg 1
 7108 AE, Winterswijk
 The Netherlands

Declares that heat pumps types:

- HPX06A, HPX12A, HPX16A & HPX30A

are in accordance with the essential requirements of the relevant EU directives, being:

Directives / regulations	Test Standard
Low Voltage Directive 2014/35/EU	EN60335-1:2012+A11:2014+A13:2017 EN60335-2-40:2003+A11:2004+A12:2005 +A1:2006+A2:2009+A13:2012+AC:2013 EN62233:2008
EMC directive 2014/30/EU	EN55014-1:2021 EN55014-2:2021 EN61000-3-2019 EN61000-3-3:2013+A1:2019
Energy-related products Directive: 2009/125/EC Commission Regulation (EU) No 206/2012	EN 14825:2016 EN 14511-2,3:2013 EN 12102-1:2017

Goods should be installed and used in accordance with our instructions and with the applicable local and international rules. Installation should be done by an authorized, qualified and competent installer.

Signed on behalf of the manufacturer:



Ir. M. Fiselier
 Technical director

