

# RLF 320 LED

LED

IP 66



IK08



-40 +50



- High color rendering index CRI 80
- Estimated service life 100000 hours
- With OVP, OCP, OTP protection
- Autonomous reactivation after recovery
- CCT4700K / other CCT on request



## CONSTRUCTION

Enclosure: aluminum powder painted casting  
 Diffuser: borosilicate glass,  
 Accessories: assembly kit for wall, pipe and ceiling mounting  
 Gasket: silicon

## TECHNICAL DATA

<b>Certificate:</b>	FIDI 23 ATEX 0004
<b>Marking:</b>	CE 0722
<b>Apparatus category:</b>	II 2G II 2D
<b>Marking of explosion protection:</b>	Ex db eb op is IIC T4 Gb Ex tb op is IIIC T100°C Db
<b>Ambient temperature ATEX:</b>	-40°C ≤ T <sub>a</sub> ≤ +40 / +50°C
<b>Degree of protection:</b>	IP 66 category 1
<b>Resistance to shock:</b>	IK 08
<b>Protection class :</b>	I (protective earthing)
<b>Rated voltage:</b>	110-240 V ±10%
<b>Frequency:</b>	50 / 60 Hz
<b>Rated power:</b>	250 W, 320 W
<b>Connecting terminals:</b>	L1, L2, L3, N; max. 2 x 2,5 mm <sup>2</sup> PE terminal ; max 2x6mm <sup>2</sup>
<b>Cable entry:</b>	Connection box [3L+N+Pe] and true wiring + ISO20 metal plug
<b>Weight:</b>	24 kg
<b>Packing:</b>	The packing contains: 1 pcs 650 x 300 x 450 mm

## MOUNTING

Wall, ceiling

# LED Floodlight

## MODEL CODE

MODEL CODE	Power consumption [W]	Voltage [V]	Light fitting Luminous flux [lm]	System efficacy [lm/W]	AMBIENT TEMP.
RLF 320 LED-1	250 W	110-240V	27 000	110	-40°C ÷ +50°C
RLF 320 LED-2	320 W		34 500		-40°C ÷ +40°C

## POLAR CURVE

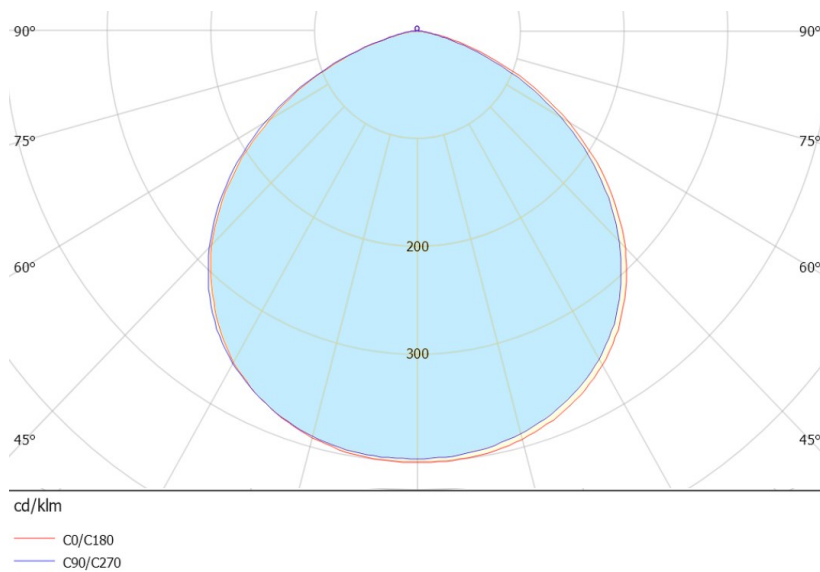

## DIMENSION DRAWING (mm)

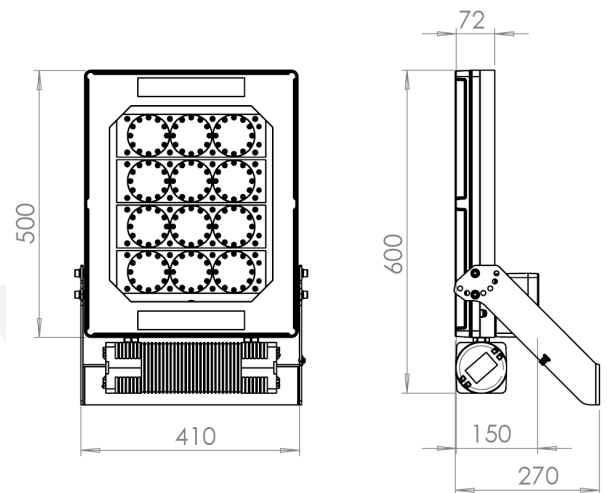

## SPARE PARTS AND ACCESSORIES

SKETCH	DESCRIPTION	CODE	SKETCH	DESCRIPTION	CODE
	Replacement glass	RLF LED 10-110		Wall/ ceiling mounting bracket	RLF LED 20-110
	LED module LEDEx 04	RLF LED 10-120		Pipe mounting set	RLF LED 20-120
	LED driver	RLF LED 10-130		Connection chamber, set	RLF 320 LED 10-140

All technical data is relevant at the time of print.