

Recessed heat interface units - SATK series

Instantaneous DHW production



SATK50 - SATK60 series



Introduction

Domestic residential energy consumption accounts for approximately one third of total energy consumption.

The constant and progressive rise in energy costs has changed the reference scenario with the consequent development of normative acts and initiatives to support energy efficiency.

The most important legislative provision on energy saving is certainly Directive 2002/91/EC concerning energy efficiency in building construction.

Thereafter, Italian legislative decree 192/2005 as amended by legislative decree 311/2005 introduced the concept of energy certification of buildings.

Consequently, the design of air conditioning systems has led to the gradual and constant reassessment of centralised systems for more rational use of conventional energy combined with the exploitation of alternative energy sources.

SATK50-60 series heat interface units are devices that combine the benefits of a centralised system in terms of energy efficiency and ease of maintenance with the freedom of independent temperature control typical of a domestic boiler. The heat interface units are also fitted for metering of the tenant heat and water consumption. The production of domestic hot water occurs instantaneously in the immediate proximity of the place of use, dispensing with the need for frequently bulky storages and complex recirculation circuits. SATK50-60 series heat interface units are compact in size and can be recess mounted in communal spaces thereby avoiding the need to occupy space inside apartments.

Product range

- SATK50103 / SATK50103HE** Recess mounted heat interface unit for LOW temperature heating, instantaneous domestic hot water production
- SATK50203 / SATK50203HE** Recess mounted heat interface unit for MEDIUM temperature heating, instantaneous domestic hot water production
- SATK50303** Recess mounted heat interface unit for HIGH temperature heating, instantaneous domestic hot water production
- SATK60103 / SATK60103HE** Recess mounted indirect heat interface unit for instantaneous domestic hot water production

WALL-MOUNTED HEAT INTERFACE UNIT INSTANTANEOUS DOMESTIC HOT WATER PRODUCTION - SATK50 SERIES

SATK50103 LOW temperature heat interface unit
SATK50103HE LOW temperature heat interface unit with high efficiency pump



- Heating range 25–45°C
- Set point regulation
- DHW production range 42–60°C

Settable optional functions:

- | | |
|-----------------------|--|
| Domestic water cycle: | - DHW exchanger preheating |
| Heating cycle: | - modulating temperature regulation with compensated set point |
| | - floor slab heating function |

SATK50203 MEDIUM temperature heat interface unit
SATK50203HE MEDIUM temperature heat interface unit with high efficiency pump



- Heating range 50–75°C
- Set point regulation
- DHW production range 42–60°C

Settable optional functions:

- | | |
|-----------------------|--|
| Domestic water cycle: | - DHW exchanger preheating |
| Heating cycle: | - modulating temperature regulation with compensated set point |

SATK50303 HIGH temperature heat interface unit



- Max. heating temperature 85°C
- ON/OFF regulation
- DHW production range 42–60°C

Settable optional functions:

- | | |
|-----------------------|----------------------------|
| Domestic water cycle: | - DHW exchanger preheating |
|-----------------------|----------------------------|

SATK50/HE technical specifications

Materials

Components:	brass EN 12165 CW617N
Fitting pipes:	steel
Frame:	RAL 9010 painted steel
Heat exchanger:	brazed stainless steel

Performance

Medium:	water
Maximum percentage of glycol:	30%
Maximum medium temperature:	85°C
Maximum working pressure:	- primary circuit: 10 bar - domestic circuit: 10 bar
Nominal DHW exchanger capacity:	50 kW (prim. 80°C)
Maximum recommended primary circuit flow rate:	1,2 m³/h
DHW circuit max. flow rate:	20 l/min (prim. 80°C)
Minimum flow to activate domestic water flow meter:	2,7 l/min ±0,3
Maximum differential pressure on domestic waters modulating valve (Δp):	0,9 bar
Maximum differential pressure on mixing valve (Δp):	0,9 bar
Electric supply:	230 V (ac) ±10% 50 Hz
Power consumption:	- SATK50 105 W - SATK50...HE 75 W
Protection class:	IP 40
Pump:	- SATK50 UPS 15-60 - SATK50...HE UPS2 15-60
Pump by-pass setting:	0,45 bar
Actuators:	stepper 24 V
Probes:	NTC 10 kΩ
Safety thermostat:	55°C ±3

Dimensions

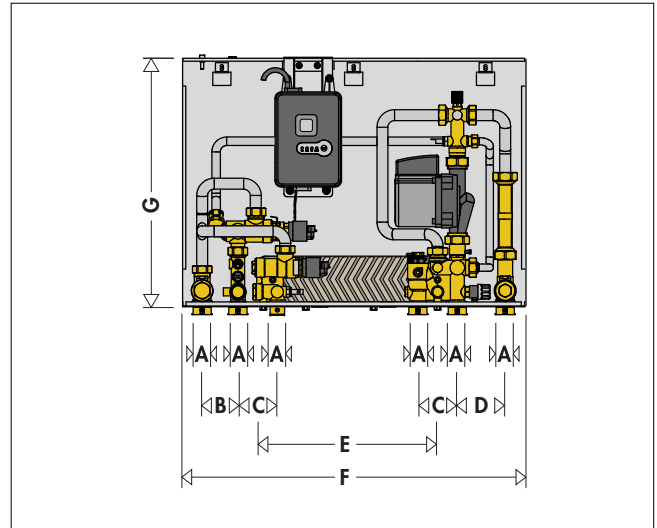

Code	A	B	C	D	E	F	G
SATK50	1"	59	65	79	232	570	410

Dimensions (W x H) with box code 794950: 600x700

Operating cycles

Domestic water cycle

This cycle always takes priority over the heating cycle.

When DHW cycle activation is requested, due to the running of user's tap (detected by the domestic water flow meter), the controller opens the modulating valve so as to quickly adjust the temperature detected by the domestic water probe to the selected set point value.

When tapping ends, the modulating valve is fully closed. The active domestic water cycle is signalled by the yellow DHW LED which comes on.

The set point temperature value of the domestic water cycle can be set using the P1 trimmer to a value within the range of 42–60°C and shown on the display (see page 13).

Heating cycle

Set point regulation.

SATK50103 - LOW temperature

SATK50203 - MEDIUM temperature

When heating cycle activation is requested by the room thermostat, the circulation pump is powered while the related mixing valve is opened gradually until the set point temperature is reached.

At the end of the heating cycle, the circulation pump comes to a stop and the mixing valve is closed.

The active heating cycle is signalled by the yellow CH LED which comes on.

The heating cycle temperature set point can be set using trimmer P2 and shown on the display (see page 13).

Heating cycle

ON/OFF regulation

SATK50303 - HIGH temperature

When the room thermostat requests the start of a heating cycle, the related valve is opened completely in such a way as to allow the primary medium to circulate through the apartment circuit at the temperature supplied by the central heating system (ON-OFF regulation).

The valve is re-closed on completion of the heating cycle.

The active heating cycle is signalled by the yellow CH LED which comes on.

Safety and alarms

Error codes associated with faults signalled by the lighting up of the FAULT LED are also shown on the display (see instruction manual).

Optional functions

Domestic water cycle

DHW preheating function

The function is enabled by setting DIP switch 5 (see page 13) to the ON position.

During periods when the domestic water cycle is not used, if the DHW probe detects a temperature 10°C below the SET value, the controller partially opens the domestic water modulating valve for the time required (max. 5 mins) to bring the temperature detected up to a value 5°C below the set point value.

The active domestic water cycle is signalled by the flashing yellow DHW LED. This function is less of a priority than any domestic water or heating cycles.

Heating cycle

Modulating temperature regulation with compensated set point.

SATK50103 - LOW temp. / SATK50203 - MEDIUM temp.

The function is enabled by setting DIP switch 1 (see page 13) to the OFF position. When the function is enabled, the flow temperature is modified according to the temperature detected by the compensation probe (located on the user return pipe). This keeps the actual thermal output of the slab - and therefore the ambient thermal load - under control. The thermal response time of the system is thus minimised.

Floor slab heating function

SATK50103 - LOW temperature

This facilitates the laying of underfloor heating systems at low temperatures. This function can only be activated and executed if there are no faults.

The function is activated by pressing and holding the RESET button for 8 seconds.

The yellow CH LED blinks while the floor slab heating function is in operation. The function has a duration of 240 hours, and is carried out by simulating a request to run in heating mode starting from a set point of 25°C and rising in regular intervals to a temperature of 45°C. Once the maximum set point has been reached, the function is executed, following the same procedures, in reverse (from the maximum set point to the minimum set point). This function has priority over heating and hot water cycles, and can be suspended at any time by pressing and holding the RESET button for 8 seconds.

SATK50103/SATK50103HE LOW temperature heat interface units



Functional characteristics

Heating range 25–45°C
Set point regulation

DHW production range 42–60°C

The heat interface unit is equipped with specific connections for the **high temperature** supply of towel warmers. *

Optional functions

Domestic cycle: - DHW preheating function

Heating cycle: - modulating regulation
with compensated set point
- floor slab heating function

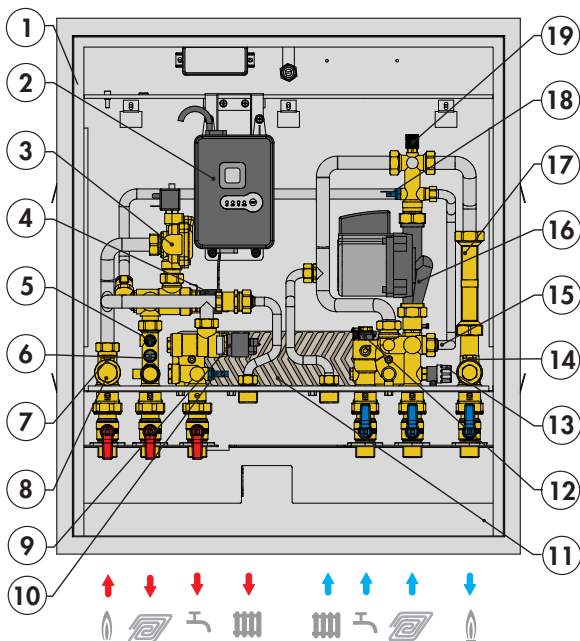

Characteristic components

1. Template box (code 794950)
2. Electronic regulator
3. Thermal safety relief valve
4. Heating mixing valve
5. Heating flow temperature probe
6. Thermal safety thermostat
7. Heat meter flow temperature probe pocket
8. System strainer
9. DHW production modulating valve
10. DHW temperature probe
11. DHW heat exchanger
12. DHW priority flow meter
13. Drain cock
14. Heat meter return temperature probe pocket
15. Protective pump by-pass
16. Pump
17. Heat meter spacer template
18. Flow temp. compensation return probe
19. Air vent cock

Hydraulic - functional diagram

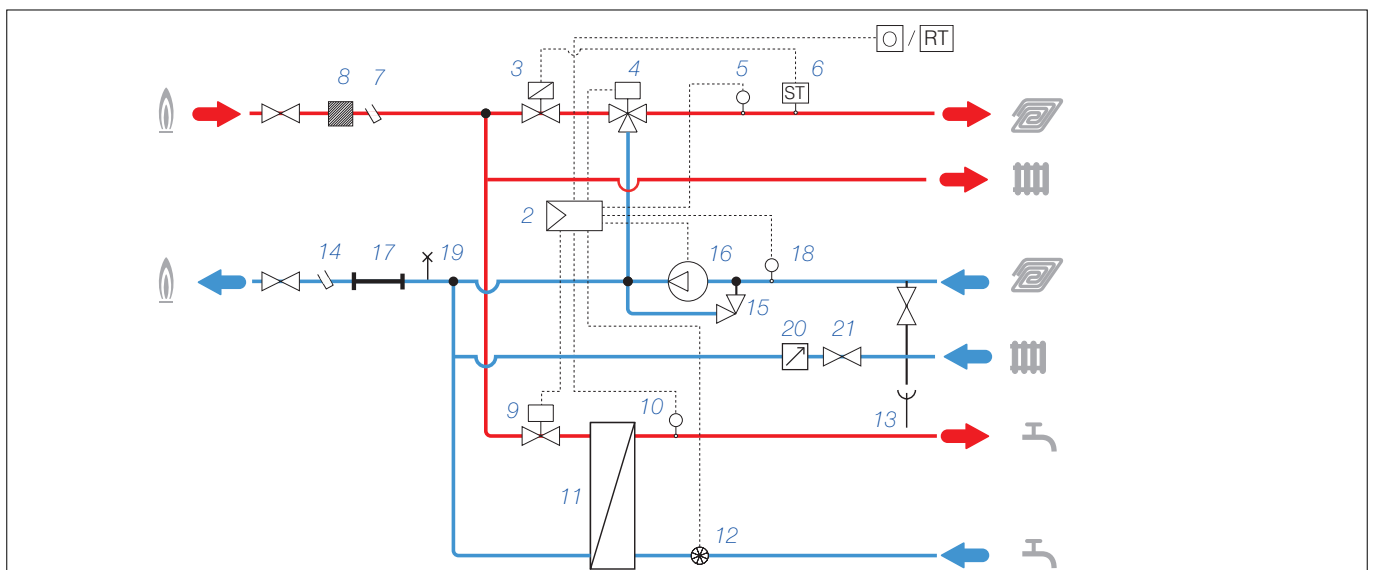

* N.B. We recommend installing an AUTOFLOW® flow rate regulator (20) and a shut-off valve (21) on the circuit serving high temperature heat emitters that must be equipped with temperature control devices.

Hydraulic characteristics

Heating function - primary
(high temperature circuit closed)

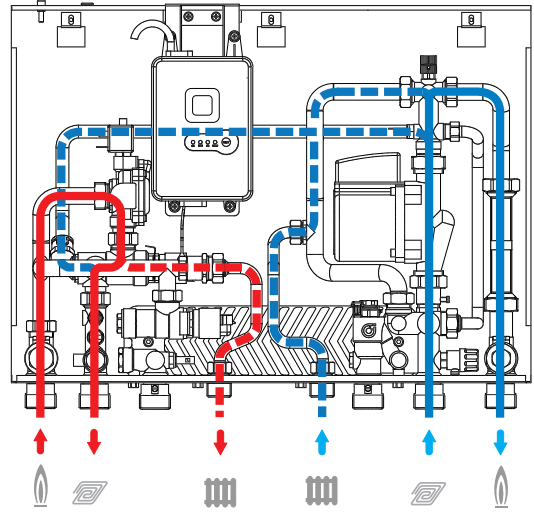
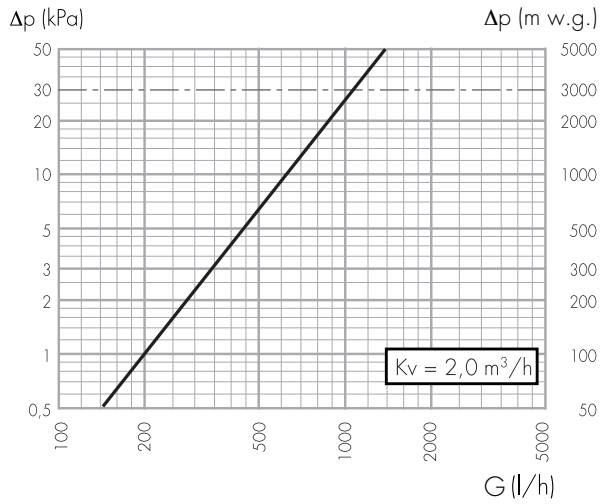

Pump fluid dynamic characteristics

UPS 15-60 (SATK50103)

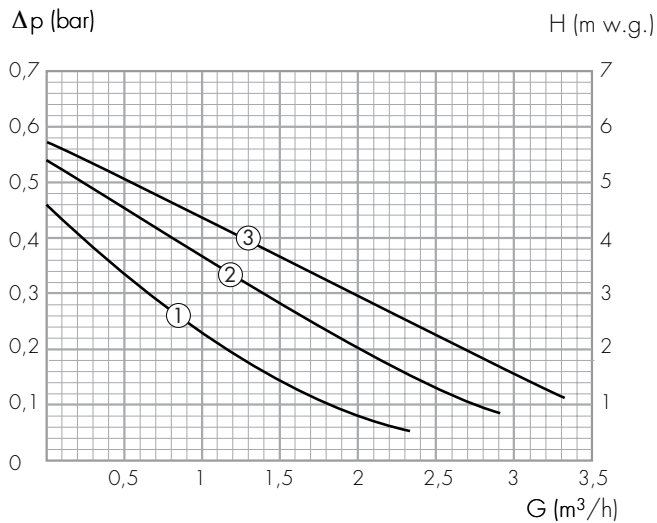

UPS2 15-60 (SATK50103HE)

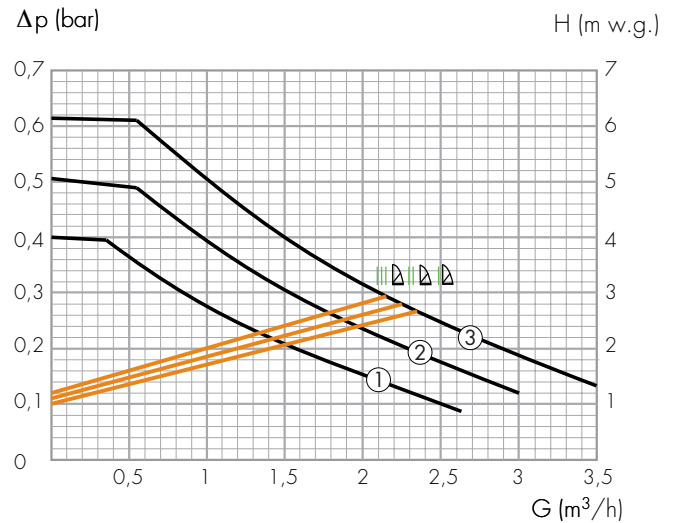

DHW function - primary side
(high temperature circuit closed)

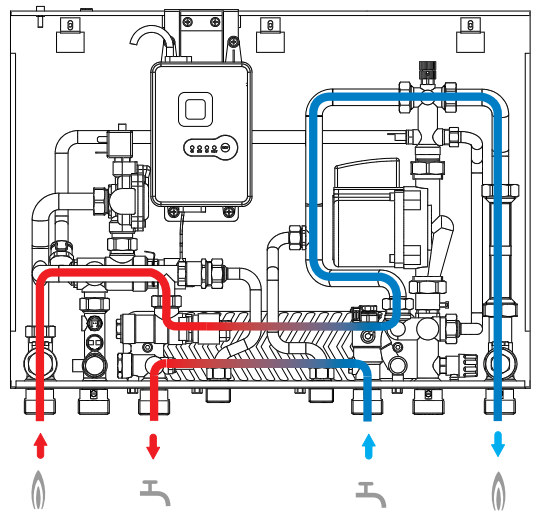
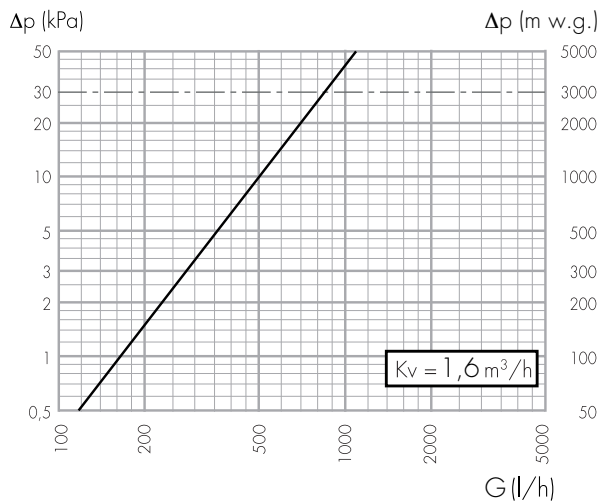

SATK50203/ SATK50203HE MEDIUM temperature heat interface units



Functional characteristics

Heating range 50–75°C
Set point regulation

DHW production range 42–60°C

Optional functions

- Domestic cycle: - DHW preheating function
- Heating cycle: - modulating regulation with compensated set point

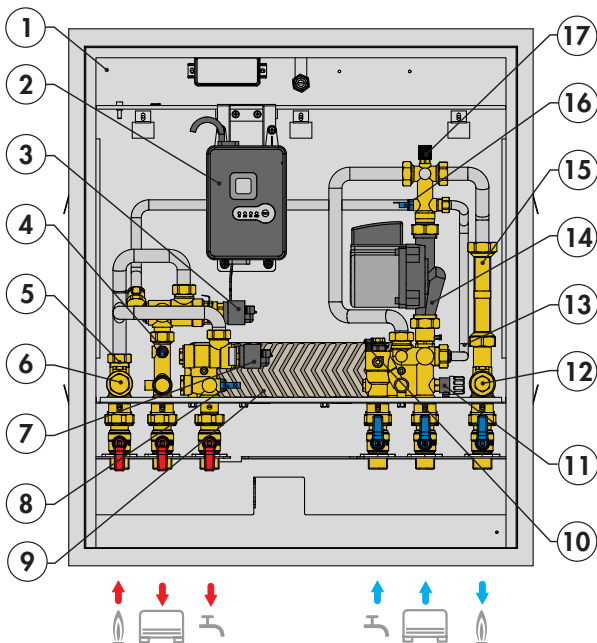

Characteristic components

1. Template box (code 794950)
2. Electronic regulator
3. Heating mixing valve
4. Heating flow temperature probe
5. Heat meter flow temperature probe pocket
6. System strainer
7. DHW production modulating valve
8. DHW temperature probe
9. DHW heat exchanger
10. DHW priority flow meter
11. Drain cock
12. Heat meter return temperature probe pocket
13. Protective pump by-pass
14. Pump
15. Heat meter spacer template
16. Flow temperature compensation return probe
17. Air vent cock

Hydraulic - functional diagram

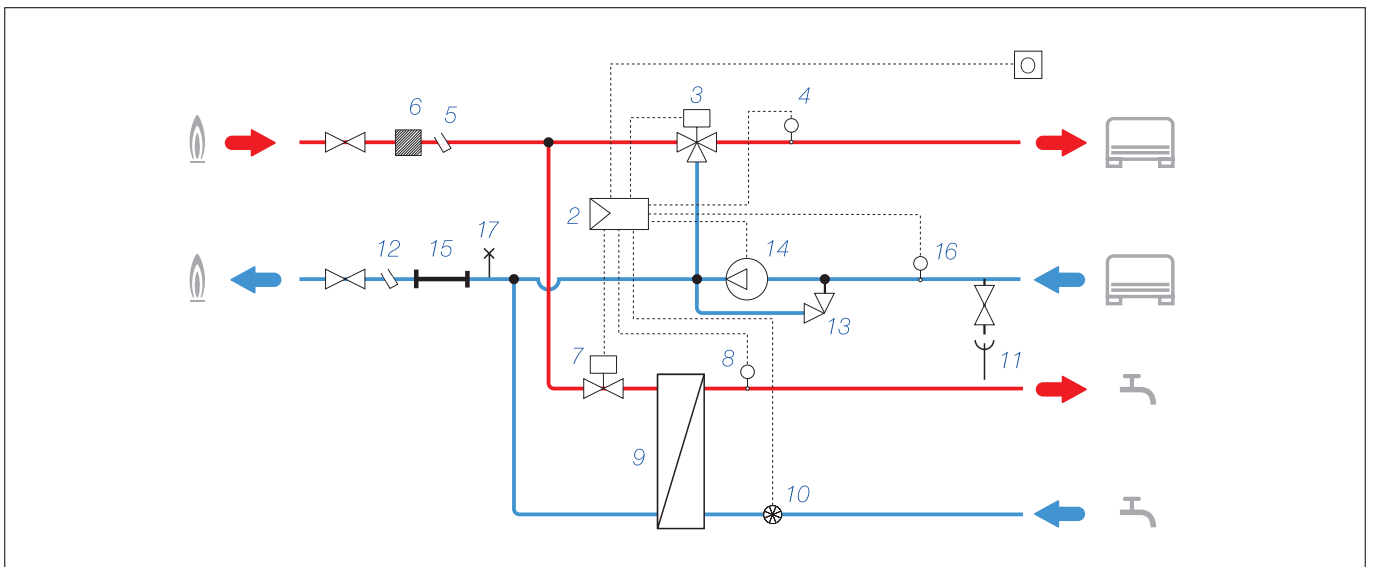

Hydraulic characteristics

Heating function - primary

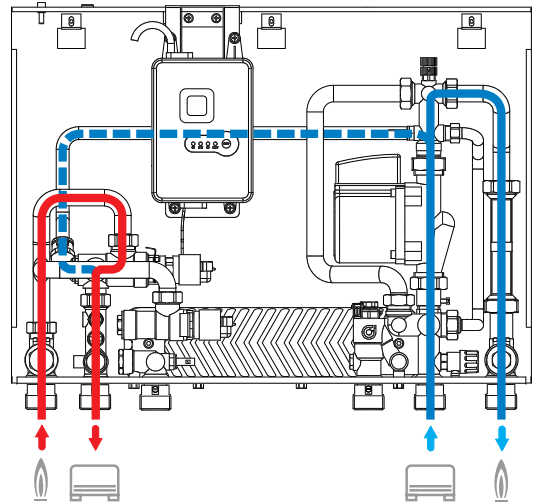

Pump fluid dynamic characteristics

UPS 15-60 (SATK50203)

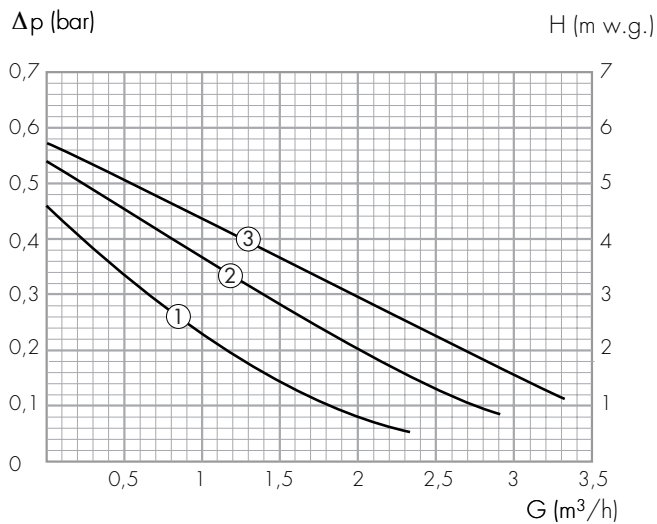

UPS2 15-60 (SATK50203HE)

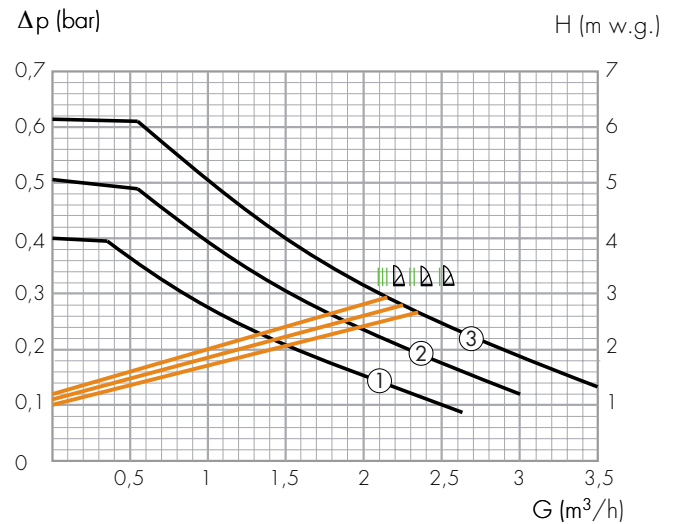

DHW function - primary side

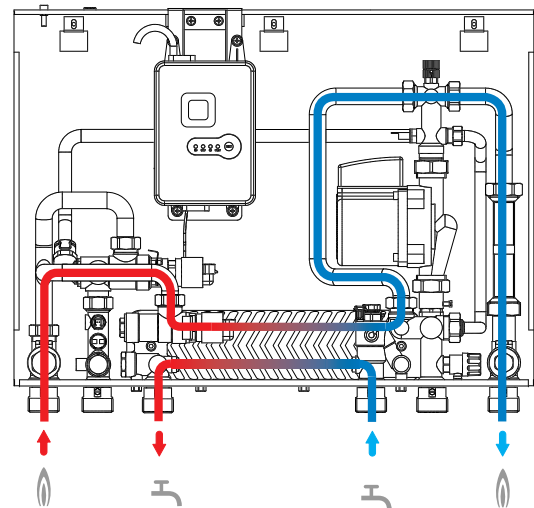
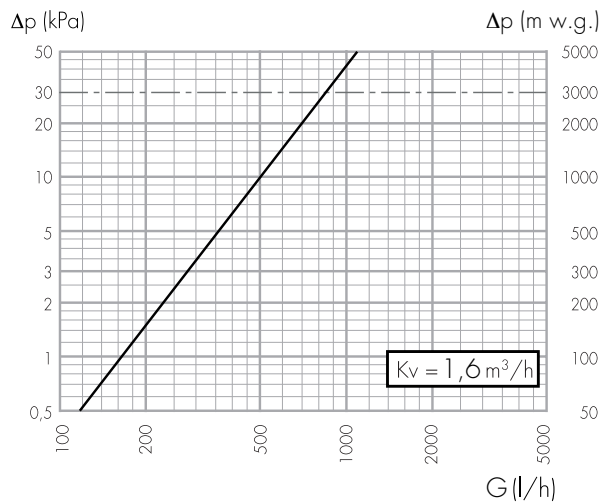

SATK50303 HIGH temperature heat interface units



Functional characteristics

Maximum heating temp. 85°C
ON/OFF regulation

DHW production range 42–60°C

Optional functions

Domestic cycle: - DHW preheating function

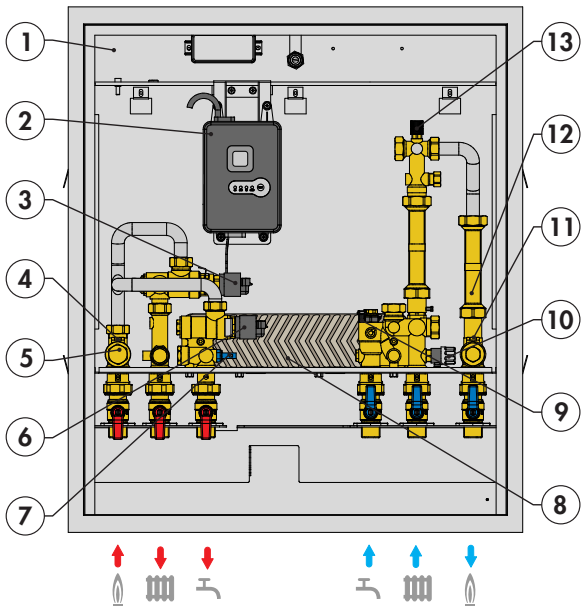

Characteristic components

1. Template box (code 794950)
2. Electronic regulator
3. Heating ON/OFF valve
4. Heat meter flow temperature probe pocket
5. System strainer
6. DHW production modulating valve
7. DHW temperature probe
8. DHW heat exchanger
9. DHW priority flow meter
10. Drain cock
11. Heat meter return temperature probe pocket
12. Heat meter spacer template
13. Air vent cock

Hydraulic-functional diagram

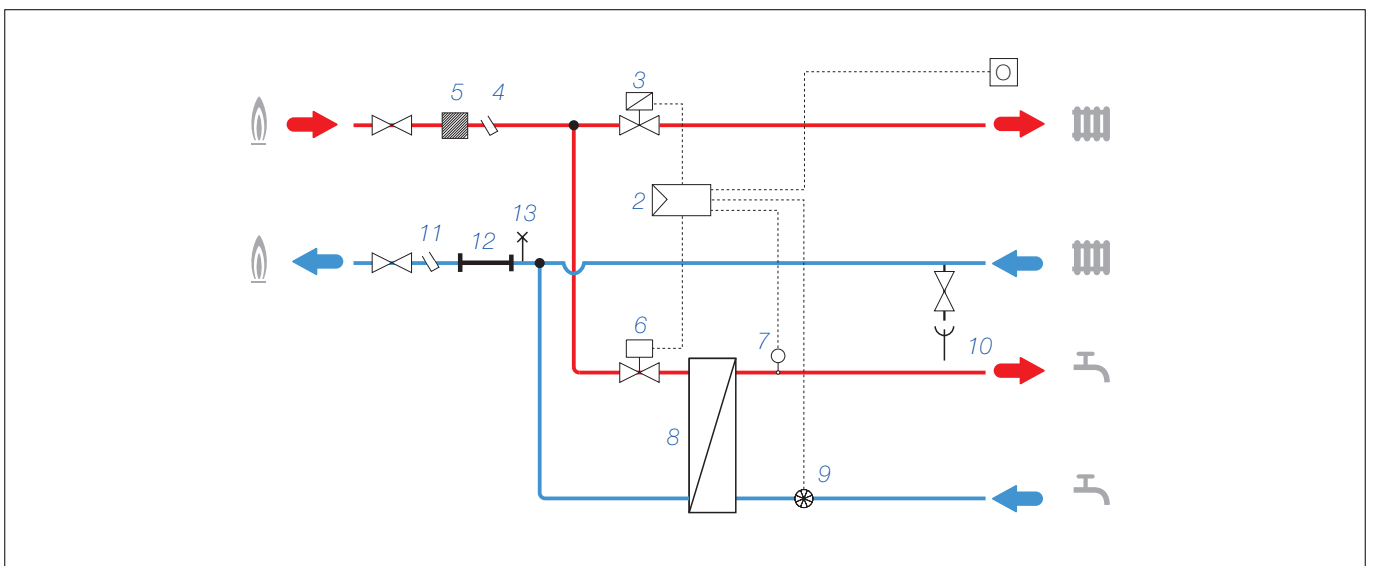

Hydraulic characteristics

Heating function - primary

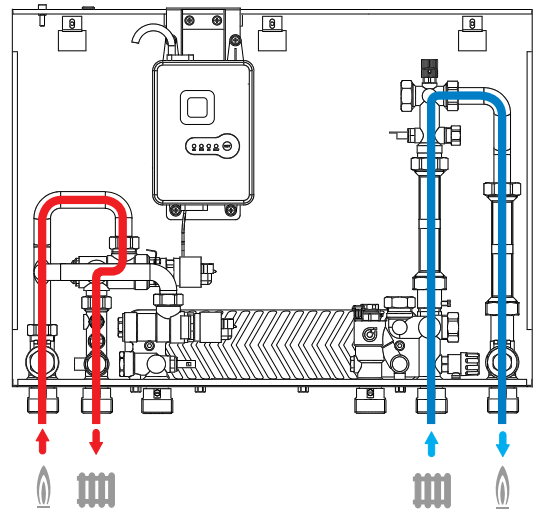
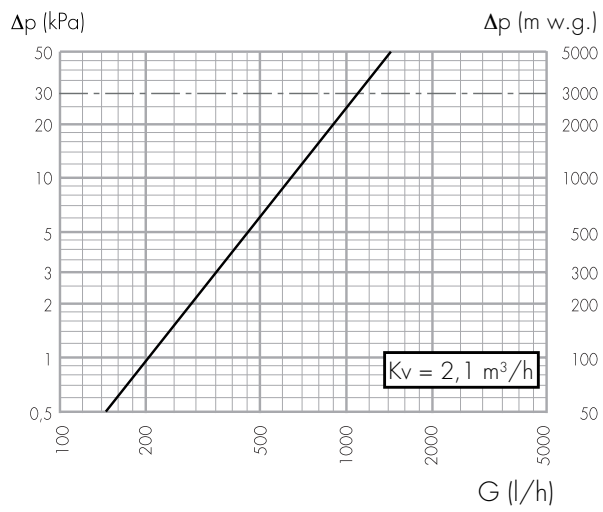

DHW function - primary side

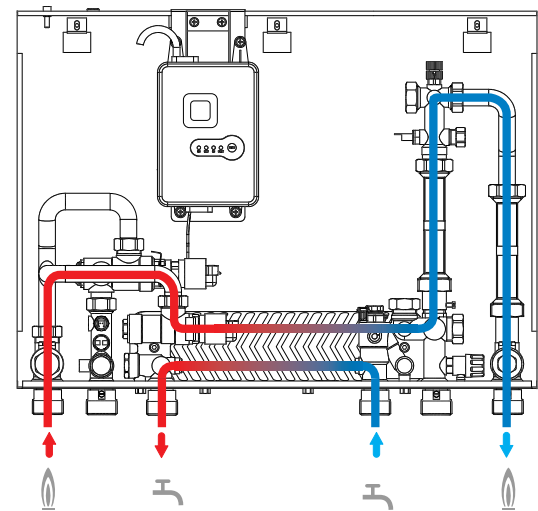
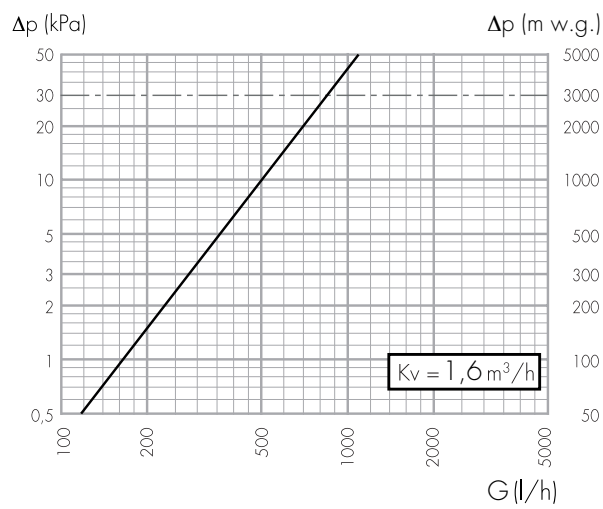

WALL-MOUNTED INDIRECT HEAT INTERFACE UNIT INSTANTANEOUS DOMESTIC HOT WATER PRODUCTION - SATK60 SERIES

SATK60103 Indirect heat interface units
SATK60103HE Indirect heat interface units with high-efficiency pump



SATK60 heat interface units are the most compact, complete and efficient solution for use in:

- dwellings supplied directly by small district heating networks without interposed substations;
- centralised systems that require high static pressures or thermal medium temperatures, which are not suitable for use in domestic systems and constitute a potential hazard.

SATK60 series heat interface units keep the primary and secondary water completely separate.

This type of device is useful when designing or redesigning the heating and domestic hot water systems of apartment buildings under renovation, as well as facilitating any maintenance required in the individual dwellings, as it eliminates the risk of impurities contaminating the entire centralised distribution network. Separation of the apartment circuit from the central plant circuit makes it possible to maintain high or very high pressure and temperature levels in the central circuit without creating a potential hazard or source of discomfort for users.

SATK60103/HE technical specifications

Materials

Components: brass EN 12165 CW617N
 Fitting pipes: steel
 Frame: RAL 9010 painted steel
 Heat exchanger: brazed stainless steel

Performance

Medium: water
 Maximum percentage of glycol: 30%
 Maximum thermal medium temperature: 85°C
 Maximum working pressure: - primary circuit: 16 bar
 - secondary circuit: 3 bar
 - domestic circuit: 10 bar
 Nominal heating exchanger capacity: 15 kW
 Nominal DHW exchanger capacity: 50 kW (prim. 80°C)
 Maximum recommended primary circuit flow rate: 0,9 m³/h
 DHW circuit max. flow rate: 20 l/min (prim. 80°C)
 Minimum flow to activate domestic water flow meter: 2,7 l/min ±0,3
 Maximum differential pressure on modulating valves (Δp): 0,9 bar
 Electric supply: 230 V (ac) ±10% 50Hz
 Power consumption: - SATK60 105 W
 - SATK60...HE 75 W
 Protection class: IP 40
 Pump: - SATK60 UPS 15-60
 - SATK60...HE UPS2 15-60
 Pump by-pass setting: 0,45 bar
 Actuators: stepper 24 V
 Probes: NTC 10 k Ω
 Safety relief valve setting: 3 bar
 Safety thermostat: 55°C ±3
 Expansion vessel: 7 l
 Pressure switch: opening 0,4 bar - closing 0,8 bar

Dimensions

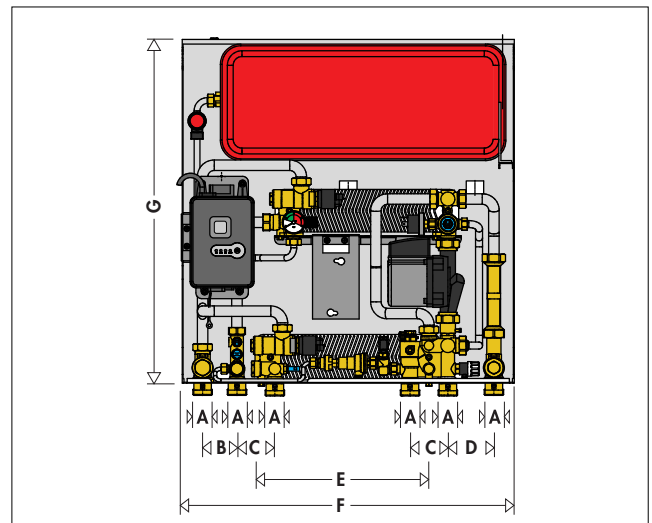

Code	A	B	C	D	E	F	G
SATK60	1"	59	65	79	232	570	590

Dimensions (W x H) with box code 794960: 625x890

Operating cycles

Domestic water cycle

This cycle always takes priority over the heating cycle.

When DHW is requested by the user, detected by the domestic water flow meter, the controller commands the opening of the modulating valve so as to adjust the temperature detected by the domestic water probe to the selected set point value.

When tapping ends, the modulating valve is fully closed.

The active domestic water cycle is signalled by the yellow DHW LED which comes on.

The general domestic water cycle temperature set point can be set using trimmer P1 and shown on the display.

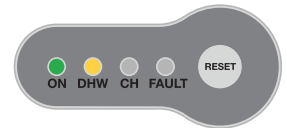
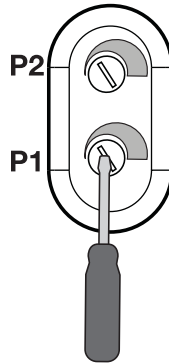

Heating cycle

Set point regulation

When heating cycle activation is requested by the room thermostat, the circulation pump is powered while the modulating valve is opened gradually until the set point temperature is reached.

At the end of the heating cycle, the circulation pump comes to a stop and the modulating valve is closed.

The active heating cycle is signalled by the lighting of the yellow CH LED.

The heating cycle temperature set point can be set using trimmer P2 and shown on the display.

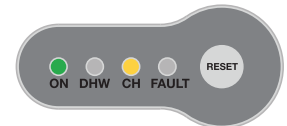
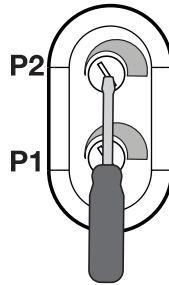

Floor slab heating function (at LOW temperature setting)

This facilitates the laying of underfloor heating systems at low temperatures. This function can only be activated and executed if there are no faults.

It can be activated by pressing and holding the RESET button for 8 seconds.

The yellow CH LED blinks while the floor slab heating function is in operation.

The function has a duration of 240 hours, and is carried out by simulating a request to run in heating mode starting from a set point of 25°C and rising in regular intervals to a temperature of 45°C. Once the maximum set point has been reached, the function is executed, following the same procedures, in reverse (from the maximum set point to the minimum set point).

This function has priority over heating and domestic water cycles, and can be suspended at any time by pressing and holding the RESET button for 8 seconds.



Domestic cycle

DHW preheating function

The function is enabled by setting dip switch 5 to the ON position. During periods when the domestic water cycle is not used, if the DHW probe detects a temperature 10°C below the SET value, the controller partially opens the domestic water modulating valve for the time required (max. 5 mins) to bring the temperature detected up to a value 5°C below the set point value.

The domestic water preheating function is signalled by the flashing yellow DHW LED.

This function is less of a priority than any domestic water or heating cycles.

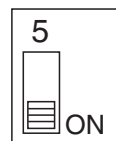

Heating cycle

Modulating temperature regulation with compensated set point

The function is enabled by setting dip switch 1 to the OFF position. When the function is enabled, the flow temperature is modified according to the temperature detected by the compensation probe. This keeps the actual thermal output of the slab - and therefore the ambient thermal load - under control. The thermal response time of the system is thus minimised.

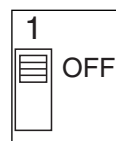

Safety and alarms

Error codes associated with faults signalled by the lighting up of the FAULT LED are also shown on the display (see instruction manual).



Functional characteristics

Heating range

- LOW temperature setting 25–45°C
- MEDIUM/HIGH temperature setting 50–75°C

Set point regulation

DHW production range 42–60°C

Optional functions

- Domestic cycle: - DHW preheating function
- Heating cycle at LOW temperature setting:
 - modulating regulation with compensated set point
 - floor slab heating function

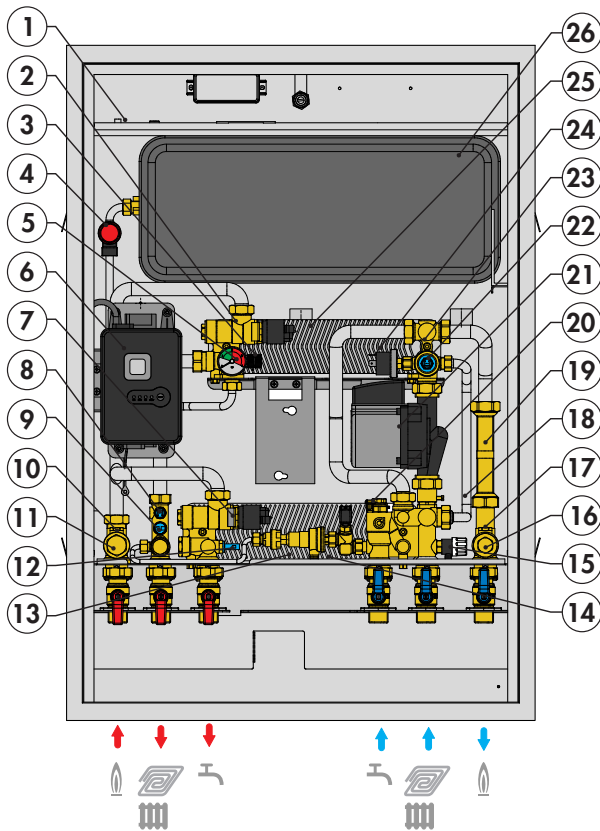

Characteristic components

1. Template box (code 794960)
2. 2-way modulating valve (primary heating)
3. Heating circuit (secondary) air vent cock
4. Safety relief valve
5. Pressure gauge
6. Electronic regulator
7. DHW production modulating valve
8. Heating flow temperature probe (secondary)
9. Thermal safety thermostat
10. Heat meter flow temperature probe pocket
11. Primary circuit strainer
12. DHW temperature probe
13. DHW heat exchanger
14. Filling unit with backflow preventer
15. Heating circuit (secondary) drain cock
16. Primary circuit drain cock
17. Heat meter return temperature probe pocket
18. Protective pump by-pass
19. Heat meter spacer template
20. DHW priority flow meter
21. Pump
22. Flow temp. compensation return probe
23. Secondary circuit strainer
24. Pressure switch
25. Heating exchanger
26. Expansion vessel

Hydraulic-functional diagram

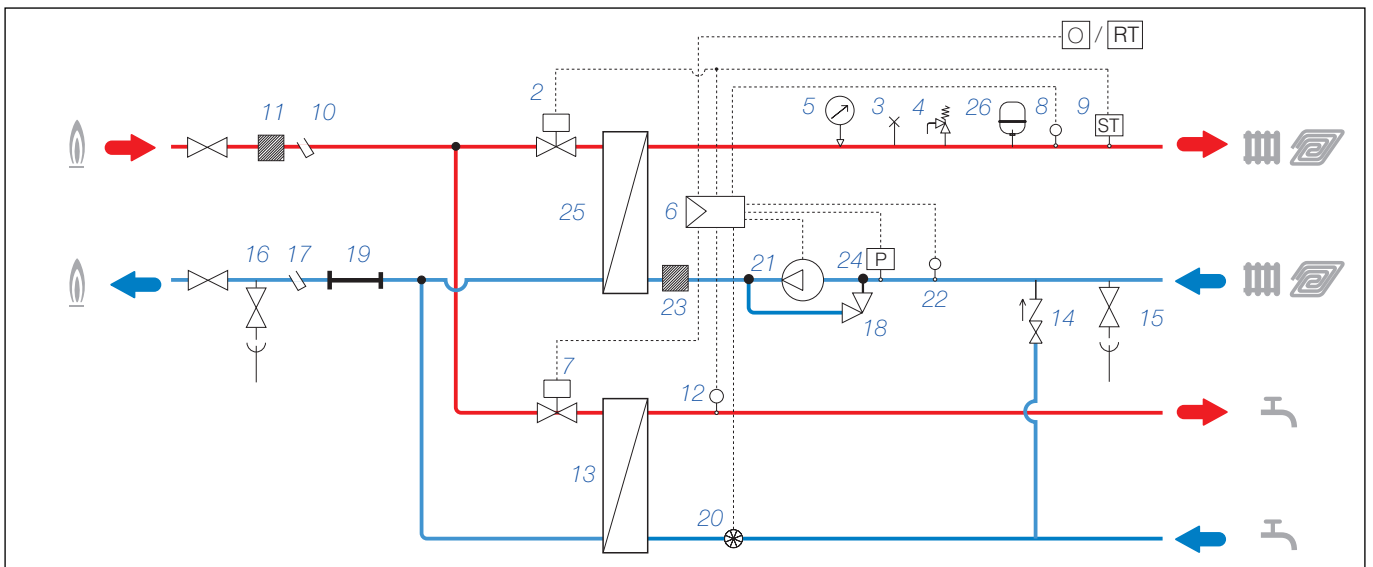

Hydraulic characteristics

Heating function - primary

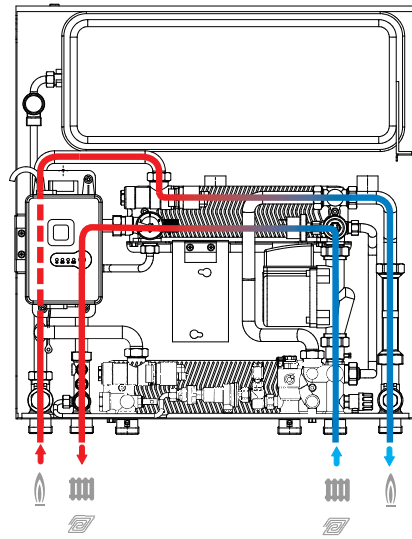

Pump fluid dynamic characteristics

UPS 15-60 (SATK60103)

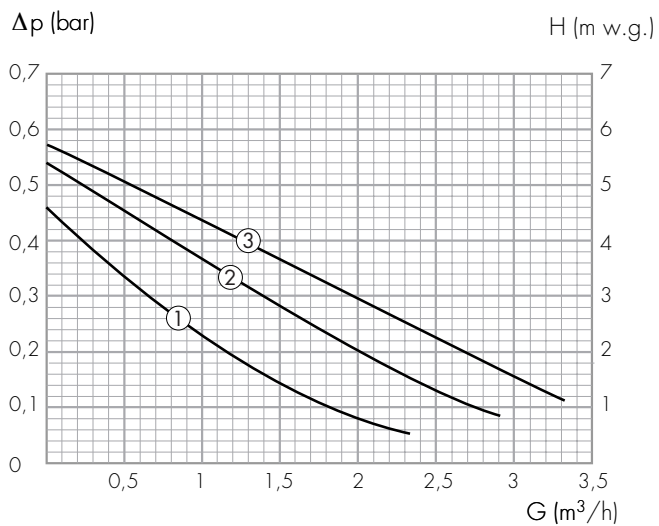

UPS2 15-60 (SATK60103HE)

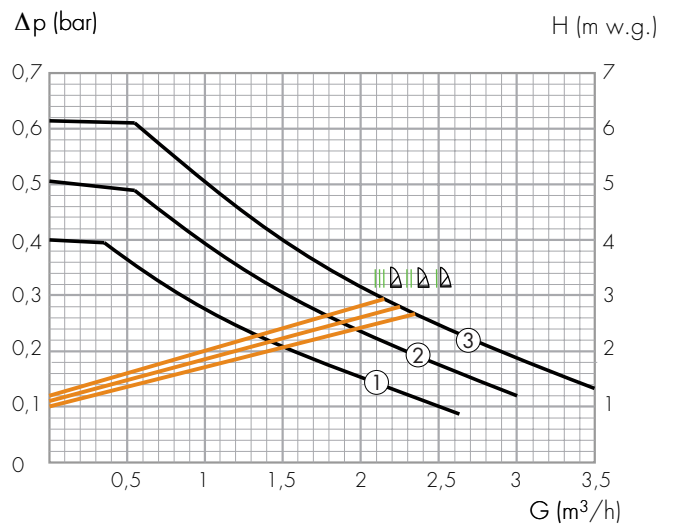

DHW function - primary side

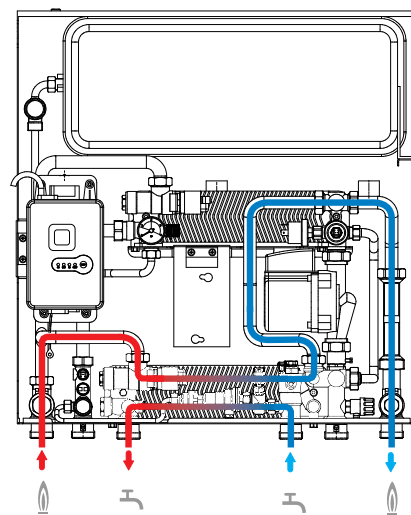
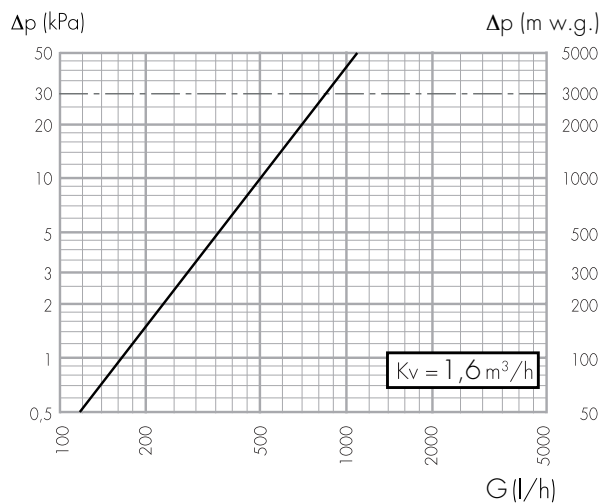

SATK50 - SATK60 series domestic hot water performance table
 DHW 10–48°C, maximum Δp 30 kPa

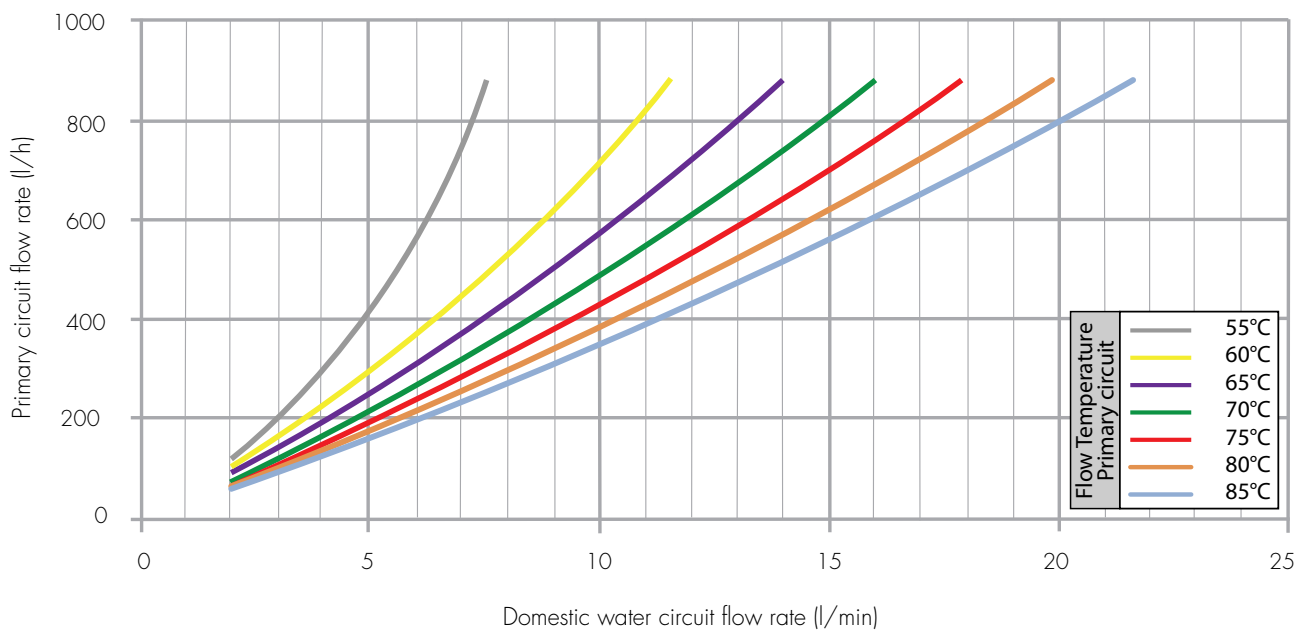
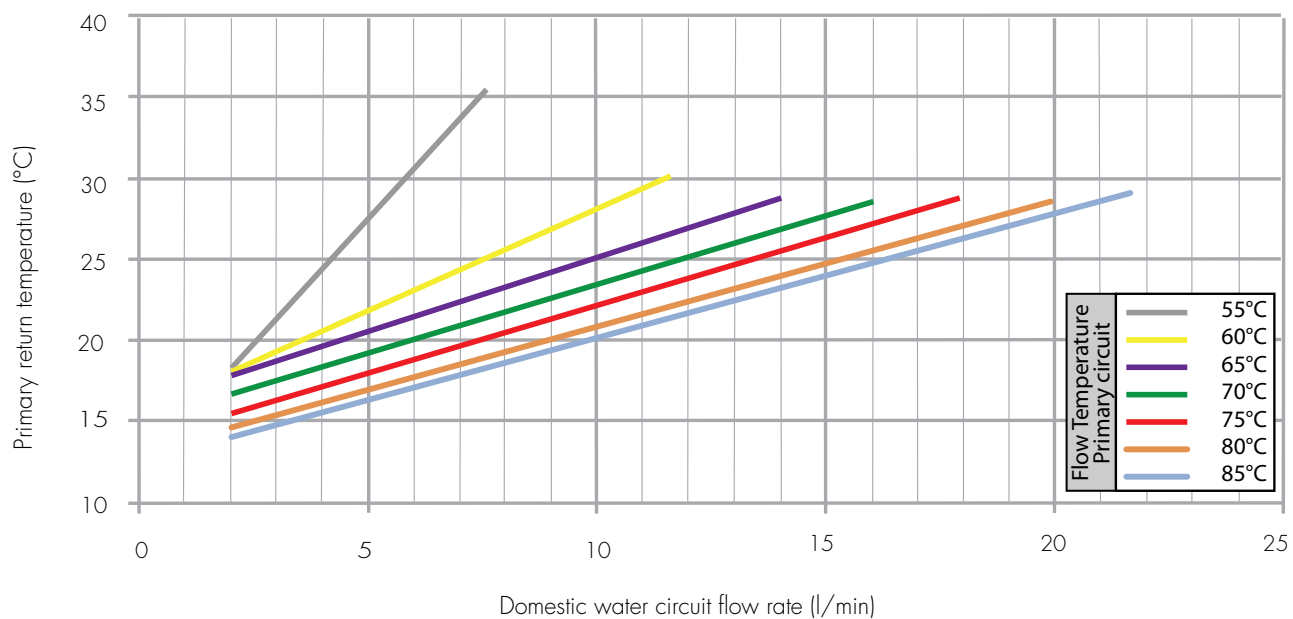

SATK50-SATK60 series domestic hot water performance at 48°C

DHW 10–48°C, primary maximum Δp 30 kPa

Primary circuit temperature (°C)	Domestic water flow rate (l/min)	Primary return temperature (°C)	Primary flow rate (l/h)	Power (kW)
55	7,5	35,5	880	20,0
60	11,5	30,1	880	30,6
65	14,0	28,8	880	37,0
70	16,0	28,6	880	42,4
75	17,9	28,7	880	47,4
80	19,8	28,6	880	52,6
85	21,6	29,1	880	57,2

Characteristics of central heating systems with instantaneous DHW production

Unlike centralised systems with DHW production in the central heating system, heat interface units make it possible to eliminate 2 of the 5 pipes that must be routed into the apartments. An initial and important benefit is obtained in terms of lower installation costs of the distribution networks.

Easy and transparent metering

Metering of consumption is achieved by means of a heat meter (for consumption related to space heating and DHW production) and a single volume meter for the total amount of domestic water without dual metering for DHW and DCW.

Standard UNI 9182 states that in the distribution of DHW the water must be delivered at the design temperature within 30 seconds of initial tapping. This may result in the need to lay the recirculation line in the apartment, making it particularly difficult to meter DHW consumption because not all the water that enters the dwelling is actual consumption. Such recirculation networks are also afflicted by serious balancing problems, since each branch must carry a limited flow rate.

Systems with instantaneous DHW do not require recirculation and the speed of response of a heat interface unit depends solely on its position inside the dwelling and the speed of its internal regulation. The SATK series heat interface units are equipped with electronic regulation that continually acts on stepper type modulating valves in order to guarantee that DHW temperature remains constant even in the presence of sudden changes in the tapped flow rate. To further reduce response times of the unit the exchanger preheating option can be activated to keep the unit constantly at operating temperature.

No risk of legionnaires' disease

Local DHW production eliminates the condition for the development of the Legionella bacteria because hot water is produced only when needed. This dispenses with the need for anti Legionella thermal disinfection of the distribution network.

No need for storages in the central heating system

As a direct consequence it becomes unnecessary to install frequently bulky storages in the central heating. A storage may be useful to increase the thermal inertia of the system, but this is a choice at the discretion of the system designer and the contents of the storage would anyway be technical water.

Easy and reduced maintenance

The greatest danger for a DHW production system, whether a heat interface unit or a domestic boiler, is the build up of limescale deposits in the heat exchanger. The higher is the domestic hot water temperature the higher is the risk of formation of limescale deposits. Since the system is equipped with electronic regulation that ensures DHW is produced directly at the temperature of use (without thermostatic mixer valves downstream of the exchanger), the water temperature in the exchanger is the minimum possible temperature; the thermal exchange efficiency is therefore maximised while the risk of formation of limescale deposits is minimised.

SATK series heat interface units are designed to ensure the easiest and fastest possible maintenance work, with extreme ease of access to and, if necessary, removal and replacement of components.

Metering in systems with centralised DHW

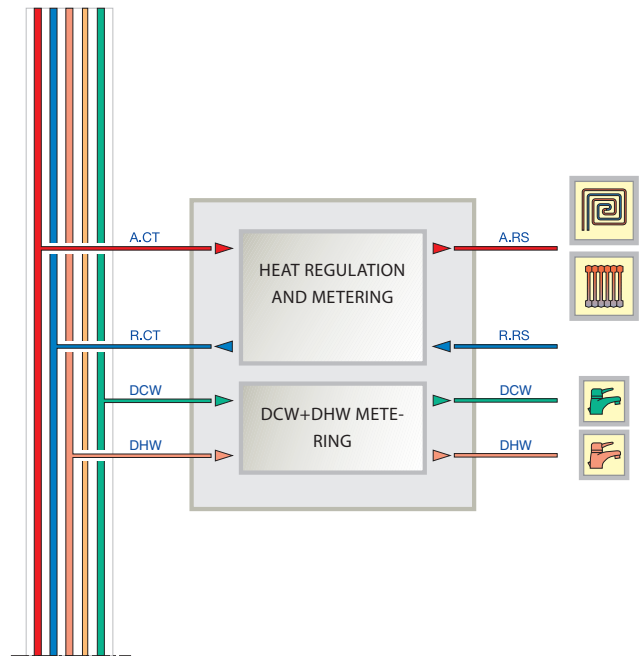

Metering in systems with instantaneous DHW

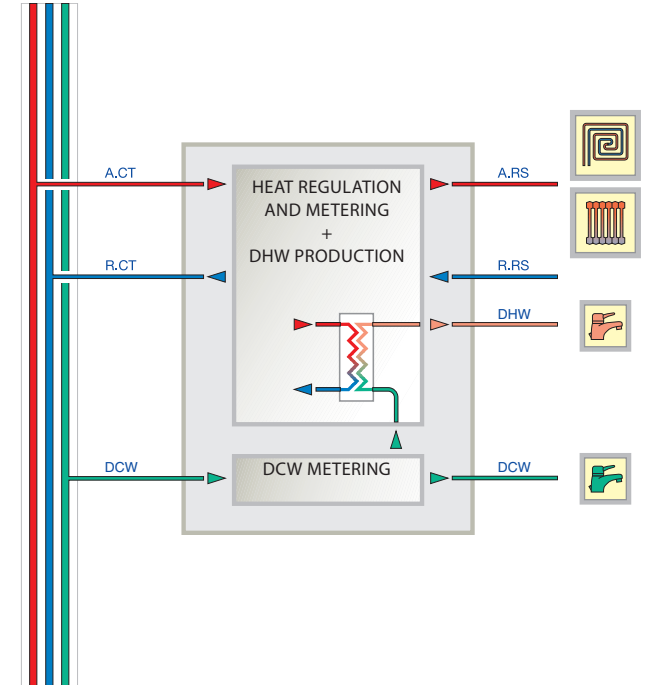

Completion codes for SATK50 and SATK60 series

7949

Recessed box for SATK50 complete with:
 - recessed box in sheet steel finished with RAL 9010 paint with cover **for interior**;
 - ball shut-off valves with 3/4" M terminal.



Code Dim. W x H (mm)

794950 600 x 700

7949

Recessed box for SATK60 complete with:
 - recessed box in sheet steel finished with RAL 9010 paint with cover **for interior**;
 - ball shut-off valves with 3/4" M terminal;



Code Dim. W x H (mm)

794960 625 x 890

794540

Domestic hot water template consisting of:
 - BALLSTOP shut-off ball valve with check valve;
 - flushing pipe.



Code

794540 1/2"

Application diagram of domestic hot water template code 794540

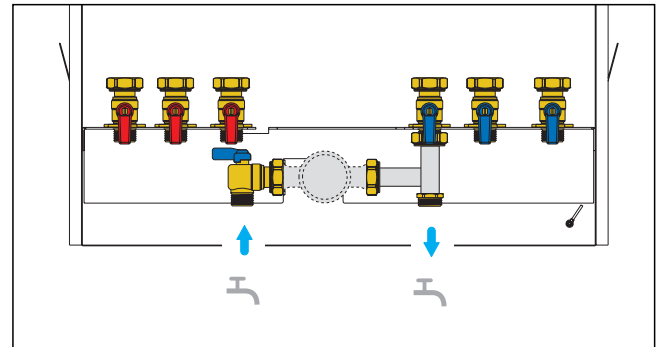

7942

Domestic cold water meter (MI001).
 With pulse output.



Conforms to directive 2004/22/EC (MI004)

Code

794204 1/2" - domestic cold water (**max 30°C**)

7554

CONTECA direct heat meter for SATK series and/or meter box code 789540.
 Equipped with an 8-digit liquid crystal display.
Centralised electric supply 24 V (ac) 50 Hz - 1 W.



Conforms to directive 2004/22/EC (MI004)



Code	Connection	Type	Q _{nom} m ³ /h	Q _{min} l/h
755404K	1/2"	single nozzle	1,5	30
755405K	3/4"	single nozzle	2,5	50



140

tech. broch. 01250

Differential pressure regulating valve.
Dezincification resistant alloy body **CR**.
Complete with capillary tube to connect to the valve on the flow pipe.

With insulation.

Max. working pressure: 16 bar.
Temperature range: -10–120°C.
Max. percentage of glycol: 50%.
Length of Ø 3 mm capillary tube: 1,5 m.



Code	Adjustable differential pressure setting (mbar)
140350	3/4" 50–300
140450	3/4" 250–600



142

tech. broch. 01250

Shut-off and pre-regulation valve
Dezincification resistant alloy body **CR**.
Complete with pressure test ports for capillary tube connection.

With insulation.

Max. working pressure: 16 bar.
Temperature range: -10–120°C.
Max. percentage of glycol: 50%.

Code	
142150	3/4"

SPECIFICATION SUMMARY

Code SATK50103/HE

Recessed two-way heat interface unit for low temperature heating with set point regulation (25–45°C) and instantaneous domestic hot water production (42–60°C), including: electronic controller, thermal safety relief valve, thermal safety thermostat, heating mixing valve, heating temperature probe, UPS 15-60 pump (UPS2 15-60 on SATK50103HE) with safety by-pass, fittings for heat meter, DHW production modulating valve, DHW temperature probe, plate heat exchanger, flow temperature compensation probe, DHW priority flow meter, air vent cock, strainer, domestic hot water exchanger preheating function, dimensions W 570 x H 410 x D 110 mm. Medium: water Maximum percentage of glycol: 30%. Maximum medium temperature: 85°C. Maximum working pressure: primary circuit: 10 bar, domestic circuit: 10 bar. Nominal DHW exchanger capacity: 50 kW (primary flow 80°C, DCW 10°C). Maximum recommended primary circuit flow rate: 1,2 m³/h. Maximum domestic water circuit flow rate: 20 l/min (primary flow 80°C, DCW 10–48°C). Minimum flow to activate domestic flow meter: 2,7 l/min ±0,3. Maximum differential pressure on modulating valve: 0,9 bar. Maximum differential pressure on mixing valve: 0,9 bar. Electric supply: 230 V (ac) ±10% 50 Hz. Power consumption: 105 W (SATK50103HE 75 W). Protection class: IP 40. Actuators: stepper 24 V. Probes: NTC 10 kΩ. Brass components. Steel connecting pipes

Code SATK50203/HE

Recessed two-way heat interface unit for medium temperature heating with set point regulation (50–75°C) and instantaneous domestic hot water production (42–60°C), including: electronic controller, heating mixing valve, heating temperature probe, UPS 15-60 pump (UPS2 15-60 on SATK50203HE) with safety by-pass, fittings for heat meter, DHW production modulating valve, DHW temperature probe, plate heat exchanger, DHW priority flow meter, air vent cock, strainer, DHW exchanger preheating function, dimensions L 570 x H 410 x D 110 mm. Medium: water. Maximum percentage of glycol: 30%. Maximum medium temperature: 85°C. Maximum working pressure: primary circuit: 10 bar, domestic circuit: 10 bar. Nominal DHW exchanger capacity: 50 kW (primary flow 80°C, DCW 10°C). Maximum recommended primary circuit flow rate: 1,2 m³/h. Maximum DHW circuit flow rate: 20 l/min (primary flow 80°C, DCW 10–48°C). Minimum flow to activate domestic flow meter: 2,7 l/min ±0,3. Maximum differential pressure on modulating valve: 0,9 bar. Maximum differential pressure on mixing valve: 0,9 bar, Electric supply: 230 V (ac) ±10% 50 Hz. Power consumption: 105 W (SATK50203HE 75 W). Protection class: IP 40. Actuators: stepper 24 V. Probes: NTC 10 kΩ. Brass components. Steel connecting pipes.

Code SATK50303

Recessed two-way heat interface unit for high temperature heating with ON/OFF regulation and instantaneous domestic hot water production (42–60°C), including: electronic controller, heating valve, fittings for heat meter, DHW production modulating valve, DHW temperature probe, plate heat exchanger, DHW priority flow meter, air vent cock, strainer, DHW exchanger preheating function, dimensions L 570 x H 410 x D 110 mm. Medium: water Maximum percentage of glycol: 30%. Maximum medium temperature: 85°C. Maximum working pressure: primary circuit: 10 bar, domestic circuit: 10 bar. Nominal DHW exchanger capacity: 50 kW (primary flow 80°C, DCW 10°C). Maximum recommended primary circuit flow rate: 1.2 m³/h. Maximum DHW circuit flow rate: 20 l/min (primary flow 80°C, DCW 10–48°C). Minimum flow to activate domestic flow meter: 2,7 l/min ±0,3. Maximum differential pressure on modulating valve: 0,9 bar. Electric supply: 230 V (ac) ±10% 50 Hz. Power consumption: 20 W. Protection class: IP 40. Actuators: stepper 24 V. Probes: NTC 10 kΩ. Brass components. Steel connecting pipes.

Code SATK60103/HE

Wall-mounted, two-way indirect heat interface unit (double exchanger) for low temperature heating with set point regulation (25–45°C), medium temperature with set point regulation (50–75°C) and instantaneous domestic hot water production (42–60°C), including: electronic controller, thermal safety thermostat, heating modulating valve, heating temperature probe, UPS 15-60 pump (UPS2 15-60 on SATK60103HE) with safety by-pass, fittings for heat meter, DHW production modulating valve, DHW temperature probe, 2 plate heat exchangers, flow temperature compensation probe, DHW priority flow meter, air vent cock, strainer, filling unit with backflow preventer, safety relief valve (3 bar), expansion vessel (7 l), pressure switch, pressure gauge, DHW preheating function, dimensions L 570 x H 590 x D 110 mm. Medium: water Maximum percentage of glycol: 30%. Maximum medium temperature: 85°C. Maximum working pressure: primary circuit: 16 bar, secondary circuit: 3 bar, domestic circuit: 10 bar. Nominal DHW exchanger capacity: 50 kW (primary 80°C, DCW 10°C). Nominal heating exchanger capacity: 15 kW. Maximum recommended primary circuit flow rate: 1,2 m³/h, Maximum domestic circuit flow rate: 20 l/min (primary flow 80°C, DCW 10–48°C). Minimum flow to activate domestic flow meter: 2,7 l/min ±0,3. Maximum differential pressure on modulating valves: 0,9 bar. Electric supply: 230 V (ac) ±10% 50 Hz. Power consumption: 105 W (SATK60103HE 75 W). Protection class: IP 40. Actuators: stepper 24 V. Probes: NTC 10 kΩ. Brass components. Steel connecting pipes.

7949 series

Recessed box for SATK50 and SATK60 complete with sheet steel box finished with RAL 9010 paint with cover, for interiors. Ball shut-off valves with 3/4" M terminal.

We reserve the right to make changes and improvements to the products and related data in this publication, at any time and without prior notice.
