

Data Sheet | Item Number: 771-6993/106-102

pre-assembled connecting cable; Eca; Socket/open-ended; 3-pole; Cod. A; H05VV-F 3G 1.5 mm²; 1 m; 1,50 mm²; white

<https://www.wago.com/771-6993/106-102>

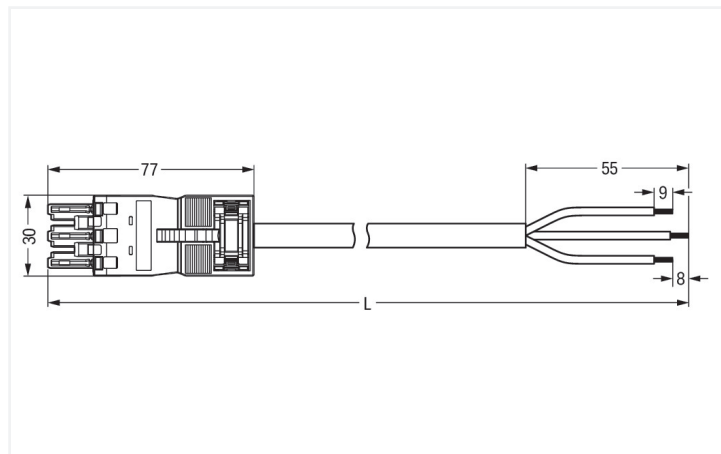

Color: ■ white

Similar to illustration

Dimensions in mm

Cable assembly *WINSTA*® MIDI rated current 16 A

The *WINSTA*® MIDI cable assembly rated current 16 A allows assembly of solid and fine-stranded conductors. The pluggable installation connectors with spring pressure connection technology function completely without screw connections. They allow flexible, error-free installation in a large number of applications. The coding options reduce installation errors, allowing fast, secure wiring of all components. General mains applications for almost any domain of use can be implemented with *WINSTA*® MIDI pluggable installation connectors with A coding. The *WINSTA*® MIDI Pluggable Connection System with Push-in CAGE CLAMP® spring pressure connection technology facilitates precise electrification. Due to the included test slot, it is possible to check connections even when they are plugged in. This saves time, labor, and money. According to the European CPR, the fire class of the cables used for construction is decisive for building safety, too. For buildings with average safety requirements, cable assemblies with fire class E are suitable.

Pluggable connections instead of screw connections – cable assemblies from WAGO

The cable assembly is provided with a socket and a free end. The *WINSTA*® Pluggable Connection System allows pluggable electrical installation. This saves time, lowers costs, and reduces the need for servicing. Enjoy the benefits of the pluggable version of our maintenance-free spring pressure connection technology too! Plan your installation with with fire class E from WAGO.

- pluggable installation connectors with protection against mismatching
- simple circuits
- for any mains application
- custom-engineered solutions
- convenient installation and commissioning

Notes

Note Cables with a different fire class can be found in the eShop.

Electrical data

Rated per	IEC/EN 60664-1		
Overvoltage category	III	III	II
Pollution degree	3	2	2
Nominal voltage	250 V	-	-
Rated impulse withstand voltage	4 kV	-	-
Rated current	16 A	-	-

General information

Note on contact resistance approx. 1 mΩ of contact resistance
approx. 0.25 mΩ contact transition plug/
socket

Connection Data

Total number of potentials	3
PE function	Preceding PE contact
Conductor preparation	ultrasonically tip-bonded

Connection 1

Strip length	9 mm / 0.35 inches
Pole number	3
Wire cross-section	1.5 mm ²
Strip length (outer insulation)	55 mm
Connection type	Socket - free end

Physical data

Pin spacing	10 mm / 0.394 inches
Width	30 mm / 1.181 inches
Height	12.9 mm / 0.508 inches
Total length	1 m

Mechanical data

Use	General mains applications
Coding	A
Variable coding	Yes
Marking	L ⊕ N
Potential marking	L ⊕ N
Mating force of a plug-in connection	approx. 20 ... 70 N (depending on pole number)
Retention force of a plug-in connection	when locked: > 80N
Unmating force of a plug-in connection	when unlocked: approx. 20 ... 70 N (depending on pole number)
Number of mating cycles	200, without resistive load
Connection type	Socket - free end
Type of pre-assembled cable	Connecting cable
Cable type	H05VV-F 3G1.5
Protection type	IP2XD; When mated: IP2xC (These compact connectors are not designed for use in open, easily accessible areas!)

Plug-in connection

Mismating protection	Yes
Note on mismating protection	All WINSTA® components are 100% protected against mismating when: a.) plugging different numbers of poles b.) plugging while rotated 180 c.) plugging while laterally staggered d.) plugging one pole
Locking lever	Can be retrofitted
Locking of plug-in connection	Locking lever
Note on locking system	All connectors for mounted installations (snap-in versions for lighting fixtures or devices, all types of PCB and distribution connectors) are factory-equipped with locking levers to ensure plugs and sockets are securely locked. Additional locking levers are only required for flying leads (plug/socket).

Material data

Note (material data)	Information on material specifications can be found here
Color	white
Insulation material (main housing)	Polyamide (PA66)
Fire class per EN 50575	E _{ca}
Contact material	Copper or copper alloy; surface-treated
Contact Plating	Tin
Fire load	29.996 MJ
Connector color	white
Strain relief color	white
Sheathed cable color	white
Printing color of sheathed cable	black
Halogen-free	No
Silicon-free	Yes
Sheath material	PVC
Rubber cable	No
Weight	116.2 g
Copper weight of the raw cable	0.043 kg/m

Environmental requirements

Processing temperature	-5 ... +40 °C
Continuous operating temperature	-35 ... +85 °C
Note on continuous operating temperature	Cable for temperatures ≤ 70 °C (including halogen-free) Insulating parts for temperatures ≤ 105 °C

Commercial data

PU (SPU)	1 pcs
Packaging type	unpacked
Country of origin	DE
GTIN	4050821522393
Customs tariff number	85444290900

Product Classification

UNSPSC	26121629
eCl@ss 10.0	27-44-06-04
eCl@ss 9.0	27-44-06-04
ETIM 9.0	EC002587
ETIM 10.0	EC002587
ECCN	NO US CLASSIFICATION

Environmental Product Compliance

RoHS Compliance Status	Compliant, No Exemption
------------------------	-------------------------

Approvals / Certificates

General approvals



Approval	Standard	Certificate Name
CCA DEKRA Certification B.V.	IEC 61535	NTR NL-7355
KEMA/KEUR DEKRA Certification B.V.	EN 61535	71-123834

Declarations of conformity and manufacturer's declarations

Approval	Standard	Certificate Name
EU-Declaration of Confor- mity WAGO GmbH & Co. KG	-	-
UK-Declaration of Confor- mity WAGO GmbH & Co. KG	-	-

Downloads

Environmental Product Compliance

Compliance Search

Environmental Product Compliance 771-6993/106-102	↓
---	-------------------

Documentation

Bid Text

771-6993/106-102	19.02.2019	xml 3.03 KB	↓
771-6993/106-102	14.01.2015	doc 26.00 KB	↓

CAD/CAE-Data

CAE data

EPLAN Data Portal 771-6993/106-102	↓
WSCAD Universe 771-6993/106-102	↓

1 Compatible Products

1.1 Required Accessories

1.1.1 Locking system

1.1.1.1 Locking system



[Item No.: 770-101](#)
Locking lever; for flying leads; for manual operation; black

[Item No.: 770-121](#)
Locking lever; for flying leads; for manual operation; white

[Item No.: 770-111](#)
Locking lever; for flying leads; for tool operation; black

[Item No.: 770-131](#)
Locking lever; for flying leads; for tool operation; white

1.2 Optional Accessories

1.2.1 Cover

1.2.1.1 Cover



Item No.: 770-201

Lockout cap; 12-pole, separable; for sockets; Plastic; black

Item No.: 770-221

Lockout cap; 12-pole, separable; for sockets; Plastic; white

1.2.2 Installation

1.2.2.1 Mounting accessories



Item No.: 770-310

Mounting carrier; 2- to 5-pole; for flying leads; black

1.2.3 Marking

1.2.3.1 Marking strip



Item No.: 210-334

Marking strips; as a DIN A4 sheet; Strip width 5 mm; Strip length 182 mm; plain; Self-adhesive; white