

User manual



## **DISCLAIMER OF WARRANTIES AND LIMITATION OF LIABILITY**

The information, recommendations, descriptions, and safety notations in this document are based on Eaton's experience and judgment and may not cover all contingencies. If further information is required, an Eaton sales office should be consulted. Sale of the product shown in this literature is subject to the terms and conditions outlined in appropriate Eaton selling policies or other contractual agreement between Eaton and the purchaser.

THERE ARE NO UNDERSTANDINGS, AGREEMENTS, WARRANTIES, EXPRESSED OR IMPLIED, INCLUDING WARRANTIES OF FITNESS FOR A PARTICULAR PURPOSE OR MERCHANTABILITY, OTHER THAN THOSE SPECIFICALLY SET OUT IN ANY EXISTING CONTRACT BETWEEN THE PARTIES. ANY SUCH CONTRACT STATES THE ENTIRE OBLIGATION OF EATON. THE CONTENTS OF THIS DOCUMENT SHALL NOT BECOME PART OF OR MODIFY ANY CONTRACT BETWEEN THE PARTIES.

In no event will Eaton be responsible to the purchaser or user in contract, in tort (including negligence), strict liability, or otherwise for any special, indirect, incidental, or consequential damage or loss whatsoever, including but not limited to damage or loss of use of equipment, plant or power system, cost of capital, loss of power, additional expenses in the use of existing power facilities, or claims against the purchaser or user by its customers resulting from the use of the information, recommendations, and descriptions contained herein. The information contained in this manual is subject to change without notice.

Cover Photo: Eaton PowerXL DX1 series drive

## **Support services**

### **Support services**

The goal of Eaton is to ensure your greatest possible satisfaction with the operation of our products. We are dedicated to providing fast, friendly, and accurate assistance. That is why we offer you so many ways to get the support you need. Whether it is by phone, fax, or email, you can access Eaton's support information 24 hours a day, seven days a week.

Our wide range of services is listed below.

You should contact your local distributor for product pricing, availability, ordering, expediting, and repairs.

### **Website**

Use the Eaton Website to find product information. You can also find information on local distributors or Eaton's sales offices.

### **Website address**

[www.eaton.com/drives](http://www.eaton.com/drives)

### **EatonCare customer support center**

Call the EatonCare Support Center if you need assistance with placing an order, stock availability or proof of shipment, expediting an existing order, emergency shipments, product price information, returns other than warranty returns, and information on local distributors or sales offices.

Voice: 877-ETN-CARE (386-2273) (8:00 a.m.–6:00 p.m. EST)  
After-Hours Emergency: 800-543-7038 (6:00 p.m.–8:00 a.m. EST)

### **Drives technical resource center**

Voice: 877-ETN-CARE (386-2273) option 2, option 6  
(8:00 a.m.–5:00 p.m. Central Time U.S. [UTC –6])  
email: [TRCDrives@Eaton.com](mailto:TRCDrives@Eaton.com)

### **For customers in Europe, contact**

For service and support, please contact your local sales organisation.

Contact details: [Eaton.com/contacts](http://Eaton.com/contacts)

Service page: [Eaton.com/aftersales](http://Eaton.com/aftersales)

PowerXL DX1 series fiber optic option card

## Table of contents

<b>SAFETY</b> .....	<b>VIII</b>
Before commencing the installation .....	viii
Definitions and symbols .....	ix
Hazardous high voltage .....	ix
Warnings and cautions .....	ix
Motor and equipment safety .....	xii
<b>POWERXL FIBER OPTIC OPTION CARD OVERVIEW</b> .....	<b>1</b>
How to use this manual .....	1
Receiving and inspection .....	1
Option card slot compatibility .....	2
<b>FIBER OPTIC CARD INSTALLATION</b> .....	<b>3</b>
Fiber optic card connection for master-follower configurations .....	3
<b>FIBER OPTIC CARD PARAMETER LIST</b> .....	<b>4</b>
<b>MASTER-FOLLOWER SETUP</b> .....	<b>6</b>
Master-Follower Speed Control Setup (Open Loop) .....	6
Master-Follower Speed Control Setup (Closed Loop) .....	6

**List of Figures**

Figure 1. Package contents for the fiber optic card ..... 1  
Figure 2. PowerXL DX1 option card slots A, B, C, D orientation ..... 2  
Figure 3. Option cards assembly .....2  
Figure 4. Master-Follower fiber optic card connection .....3  
Figure 5. Two or more PowerXL DX1 drives system ..... 3

**List of Tables**

Table 1. Parameter B10.2 .....4

## Safety



**Warning!**  
**Dangerous electrical voltage!**

### Before commencing the installation

- Disconnect the power supply of the device
- Ensure that devices cannot be accidentally restarted
- Verify isolation from the supply
- Earth and short circuit the device
- Cover or enclose any adjacent live components
- Only suitably qualified personnel in accordance with EN 50110-1/-2 (VDE 0105 Part 100) may work on this device/system
- Before installation and before touching the device ensure that you are free of electrostatic charge
- The functional earth (FE, PES) must be connected to the protective earth (PE) or the potential equalization. The system installer is responsible for implementing this connection
- Connecting cables and signal lines should be installed so that inductive or capacitive interference does not impair the automation functions
- Install automation devices and related operating elements in such a way that they are well protected against unintentional operation
- Suitable safety hardware and software measures should be implemented for the I/O interface so that an open circuit on the signal side does not result in undefined states in the automation devices
- Ensure a reliable electrical isolation of the extra-low voltage of the 24V supply. Only use power supply units complying with IEC 60364-4-41 (VDE 0100 Part 410) or HD384.4.41 S2
- Deviations of the input voltage from the rated value must not exceed the tolerance limits given in the specifications, otherwise this may cause malfunction and dangerous operation
- Emergency stop devices complying with IEC/EN 60204-1 must be effective in all operating modes of the automation devices. Unlatching the emergency-stop devices must not cause a restart
- Devices that are designed for mounting in housings or control cabinets must only be operated and controlled after they have been installed and with the housing closed. Desktop or portable units must only be operated and controlled in enclosed housings
- Measures should be taken to ensure the proper restart of programs interrupted after a voltage DIP or failure. This should not cause dangerous operating states even for a short time. If necessary, emergency-stop devices should be implemented
- Wherever faults in the automation system may cause injury or material damage, external measures must be implemented to ensure a safe operating state in the event of a fault or malfunction (for example, by means of separate limit switches, mechanical interlocks, and so on)
- Depending on their degree of protection, variable frequency drives may contain live bright metal parts, moving or rotating components, or hot surfaces during and immediately after operation
- Removal of the required covers, improper installation, or incorrect operation of motor or variable frequency drive may cause the failure of the device and may lead to serious injury or damage
- The applicable national accident prevention and safety regulations apply to all work carried out on live variable frequency drives
- The electrical installation must be carried out in accordance with the relevant regulations (for example, with regard to cable cross sections, fuses, PE)
- Transport, installation, commissioning, and maintenance work must be carried out only by qualified personnel (IEC 60364, HD 384 and national occupational safety regulations)
- Installations containing variable frequency drives must be provided with additional monitoring and protective devices in accordance with the applicable safety regulations. Modifications to the variable frequency drives using the operating software are permitted
- All covers and doors must be kept closed during operation
- To reduce hazards for people or equipment, the user must include in the machine design measures that restrict the consequences of a malfunction or failure of the drive (increased motor speed or sudden standstill of motor). These measures include:
  - Other independent devices for monitoring safety-related variables (speed, travel, end positions, and so on)
  - Electrical or non-electrical system-wide measures (electrical or mechanical interlocks)
  - Never touch live parts or cable connections of the variable frequency drive after it has been disconnected from the power supply. Due to the charge in the capacitors, these parts may still be live after disconnection. Fit appropriate warning signs

Read this manual thoroughly and make sure you understand the procedures before you attempt to install, set up, operate or carry out any maintenance work on this PowerXL™ variable frequency drive.

## Definitions and symbols

**⚠ WARNING**

This symbol indicates high voltage. It calls your attention to items or operations that could be dangerous to you and other persons operating this equipment. Read the message and follow the instructions carefully.

**⚠**

This symbol is the "Safety Alert Symbol." It occurs with either of two signal words: CAUTION or WARNING, as described below.

**⚠ WARNING**

Indicates a potentially hazardous situation which, if not avoided, can result in serious injury or death.

**⚠ CAUTION**

Indicates a potentially hazardous situation which, if not avoided, can result in minor to moderate injury, or serious damage to the product. The situation described in the CAUTION may, if not avoided, lead to serious results. Important safety measures are described in CAUTION (as well as WARNING).

## Hazardous high voltage

**⚠ WARNING**

Motor control equipment and electronic controllers are connected to hazardous line voltages. When servicing drives and electronic controllers, there may be exposed components with housings or protrusions at or above line potential. Extreme care should be taken to protect against shock.

- Stand on an insulating pad and make it a habit to use only one hand when checking components
- Always work with another person in case an emergency occurs
- Disconnect power before checking controllers or performing maintenance
- Be sure equipment is properly earthed
- Wear safety glasses whenever working on electronic controllers or rotating machinery

**⚠ WARNING**

The components in the drive's power section remain energized after the supply voltage has been switched off. After disconnecting the supply, wait at least five minutes before removing the cover to allow the intermediate circuit capacitors to discharge.

Pay attention to hazard warnings!



**DANGER**  
**5 MIN**

**⚠ WARNING**

Electric shock hazard—risk of injuries! Carry out wiring work only if the unit is de-energized.

**⚠ WARNING**

Do not perform any modifications on the AC drive when it is connected to mains.

## Warnings and cautions

**⚠ WARNING**

Be sure to ground the unit following the instructions in this manual. Ungrounded units may cause electric shock and/or fire.

**⚠ WARNING**

This equipment should only be installed, adjusted, and serviced by qualified electrical maintenance personnel familiar with the construction and operation of this type of equipment and the hazards involved. Failure to observe this precaution could result in death or severe injury.

**⚠ WARNING**

Components within the drive are live when it is connected to power. Contact with this voltage is extremely dangerous and may cause death or severe injury.

**⚠ WARNING**

Line terminals (L1, L2, L3), motor terminals (U, V, W) and the DC link/ brake resistor terminals (DC-, DC+/R+, R-) are live when the drive is connected to power, even if the motor is not running. Contact with this voltage is extremely dangerous and may cause death or severe injury.

**⚠ WARNING**

Even though the control I/O-terminals are isolated from line voltage, the relay outputs and other I/O-terminals may have dangerous voltage present even when the drive is disconnected from power. Contact with this voltage is extremely dangerous and may cause death or severe injury.

**⚠ WARNING**

This equipment has a large capacitive leakage current during operation, which can cause enclosure parts to be above ground potential. Proper grounding, as described in this manual, is required. Failure to observe this precaution could result in death or severe injury.

**⚠ WARNING**

Before applying power to this drive, make sure that the front and cable covers are closed and fastened to prevent exposure to potential electrical fault conditions. Failure to observe this precaution could result in death or severe injury.

**⚠ WARNING**

An upstream disconnect/protective device must be provided as required by the National Electric Code® (NEC®). Failure to follow this precaution may result in death or severe injury.

**⚠ WARNING**

This drive can cause a DC current in the protective earthing conductor. Where a residual current-operated protective (RCD) or monitoring (RCM) device is used for protection in case of direct or indirect contact, only an RCD or RCM of Type B is allowed on the supply side of this product.

**⚠ WARNING**

Carry out wiring work only after the drive has been correctly mounted and secured.

**⚠ WARNING**

Before opening the drive covers:

- Disconnect all power to the drive, including external control power that may be present
- Wait a minimum of five minutes after all the lights on the keypad are off. This allows time for the DC bus capacitors to discharge
- A hazard voltage may still remain in the DC bus capacitors even if the power has been turned off. Confirm that the capacitors have fully discharged by measuring their voltage using a multimeter set to measure the DC voltage

Failure to follow these precautions may cause death or severe injury.

**⚠ WARNING**

The opening of the branch-circuit protective device may be an indication that a fault current has been interrupted. To reduce the risk of fire or electric shock, current-carrying parts and other components of the controller should be examined and replaced if damaged. If burnout of the current element of an overload relay occurs, the complete overload relay must be replaced.

**⚠ WARNING**

Operation of this equipment requires detailed installation and operation instructions provided in the Installation/Operation manual intended for use with this product. This information is provided on the CD-ROM, floppy diskette(s) or other storage device included in the container this device was packaged in. It should be retained with this device at all times.

**⚠ WARNING**

Before servicing the drive:

- Disconnect all power to the drive, including external control power that may be present
- Place a "DO NOT TURN ON" label on the disconnect device
- Lock the disconnect device in the open position

Failure to follow these instructions will result in death or serious injury.

**⚠ WARNING**

The drive outputs (U, V, W) must not be connected to the input voltage or the utility line power as severe damage to the device may occur and there may be a risk of fire.

**⚠ WARNING**

The heat sink and/or outer enclosure may reach a high temperature.  
Pay attention to hazard warnings!



Hot Surface—Risk of Burn. DO NOT TOUCH!

**⚠ CAUTION**

Any electrical or mechanical modification to this drive without prior written consent of Eaton will void all warranties and may result in a safety hazard in addition and voiding of the UL<sup>®</sup> listing.

**⚠ CAUTION**

Install this drive on flame-resistant material such as a steel plate to reduce the risk of fire.

**⚠ CAUTION**

Install this drive on a perpendicular surface that is able to support the weight of the drive and is not subject to vibration, to lessen the risk of the drive falling and being damaged and/or causing personal injury.

**⚠ CAUTION**

Prevent foreign material such as wire clippings or metal shavings from entering the drive enclosure, as this may cause arcing damage and fire.

**⚠ CAUTION**

Install this drive in a well-ventilated room that is not subject to temperature extremes, high humidity, or condensation, and avoid locations that are directly exposed to sunlight, or have high concentrations of dust, corrosive gas, explosive gas, inflammable gas, grinding fluid mist, etc. Improper installation may result in a fire hazard.

**⚠ CAUTION**

When selecting the cable cross-section, take the voltage drop under load conditions into account. The consideration of other standards is the responsibility of the user.  
The user is responsible for compliance with all international and national electrical standards in force concerning protective grounding of all equipment.

**⚠ CAUTION**

The specified minimum PE conductor cross-sections in this manual must be maintained.  
Touch current in this equipment exceeds 3.5 mA (AC). The minimum size of the protective earthing conductor shall comply with the requirements of EN 61800-5-1 and/or the local safety regulations.

**⚠ CAUTION**

Touch currents in this frequency inverter are greater than 3.5 mA (AC). According to product standard IEC/EN 61800-5-1, an additional equipment grounding conductor of the same cross-sectional area as the original protective earthing conductor must be connected, or the cross-section of the equipment grounding conductor must be at least 10 mm<sup>2</sup> Cu. Drive requires that only copper conductor should be used.

**⚠ CAUTION**

Debounced inputs may not be used in the safety circuit diagram. Residual current circuit breakers (RCD) are only to be installed between the AC power supply network and the drive.

**⚠ CAUTION**

Debounced inputs may not be used in the safety circuit diagram. If you are connecting multiple motors on one drive, you must design the contactors for the individual motors according to utilization category AC-3.  
Selecting the motor contactor is done according to the rated operational current of the motor to be connected.

**⚠ CAUTION**

Debounced inputs may not be used in the safety circuit diagram. A changeover between the drive and the input supply must take place in a voltage-free state.

**⚠ CAUTION**

Debounced inputs may not be used in the safety circuit diagram. Fire hazard!  
Only use cables, protective switches, and contactors that feature the indicated permissible nominal current value.

**⚠ CAUTION**

Before connecting the drive to AC mains make sure that the EMC protection class settings of the drive are appropriately made according to instructions in this manual.

- If the drive is to be used in a floating distribution network, remove screws at MOV and EMC
- Disconnect the internal EMC filter when installing the drive on an IT system (an ungrounded power system or a high-resistance-grounded [over 30 ohm] power system), otherwise the system will be connected to ground potential through the EMC filter capacitors. This may cause danger, or damage the drive
- Disconnect the internal EMC filter when installing the drive on a corner grounded TN system, otherwise the drive will be damaged

Note: When the internal EMC filter is disconnected, the drive might be not EMC compatible.

- Do not attempt to install or remove the MOV or EMC screws while power is applied to the drive's input terminals

## Motor and equipment safety

### CAUTION

Do not perform any megger or voltage withstand tests on any part of the drive or its components. Improper testing may result in damage.

### CAUTION

Prior to any tests or measurements of the motor or the motor cable, disconnect the motor cable at the drive output terminals (U, V, W) to avoid damaging the drive during motor or cable testing.

### CAUTION

Do not touch any components on the circuit boards. Static voltage discharge may damage the components.

### CAUTION

Before starting the motor, check that the motor is mounted properly and aligned with the driven equipment. Ensure that starting the motor will not cause personal injury or damage equipment connected to the motor.

### CAUTION

Set the maximum motor speed (frequency) in the drive according to the requirements of the motor and the equipment connected to it. Incorrect maximum frequency settings can cause motor or equipment damage and personal injury.

### CAUTION

Before reversing the motor rotation direction, ensure that this will not cause personal injury or equipment damage.

### CAUTION

Make sure that no power correction capacitors are connected to the drive output or the motor terminals to prevent drive malfunction and potential damage.

### CAUTION

Make sure that the drive output terminals (U, V, W) are not connected to the utility line power as severe damage to the drive may occur.

### CAUTION

When the control terminals of two or more drive units are connected in parallel, the auxiliary voltage for these control connections must be taken from a single source which can either be one of the units or an external supply.

### CAUTION

Do not control the motor with the disconnecting device (disconnecting means); instead, use the control panel start and stop keys and, or commands via the I/O board of the drive. The maximum allowed number of charging cycles of the DC capacitors (i.e. power-ups by applying power) is five in ten minutes.

### CAUTION

Improper drive operation:

- If the drive is not turned on for a long period, the performance of its electrolytic capacitors will be reduced
- If it is stopped for a prolonged period, turn the drive on at least every six months for at least 5 hours to restore the performance of the capacitors, and then check its operation. It is recommended that the drive is not connected directly to the line voltage. The voltage should be increased gradually using an adjustable AC source

Failure to follow these instructions can result in injury and/or equipment damage.

For more technical information, contact the factory or your local Eaton sales representative.

## PowerXL fiber optic option card overview

This chapter describes the purpose and contents of this manual, the receiving inspection of the fiber optic card and the catalog numbering system.

The fiber optic card is used when 2 or more PowerXL DX1 VFDs are required to be configured either in a speed or torque master-follower system. This card facilitates high speed signal transfer from the master or follower. The catalog number of the option card is shown below.

DXX-EXT-OF      PowerXL DX1 Fiber Optic Card

A pair of the following fiber cables are required for each master-follower connection.

DXX-CBLFBR1M    PowerXL DX1 1 Meter Fiber Optic Cable

DXX-CBLFBR5M    PowerXL DX1 5 Meter Fiber Optic Cable

DXX-CBLFBR10M   PowerXL DX1 10 Meter Fiber Optic Cable

## How to use this manual

The purpose of this manual is to provide you with information necessary to install, set and customize parameters, start up, troubleshoot and maintain the fiber optic option card in a Eaton PowerXL DX1 drive. To provide for safe installation and operation of the equipment, read the safety guidelines at the beginning of this manual and follow the procedures outlined in the following chapters before connecting power to the PowerXL DX1 drive. Keep this operating manual handy and distribute to all users, technicians and maintenance personnel for reference.

## Receiving and inspection

PowerXL DX1 VFDs and option cards have met a stringent series of factory quality requirements before shipment. It is possible that packaging or equipment damage may have occurred during shipment.

Please check to make sure that the package includes the following:

- Fiber Optic Card (DXX-EXT-OF)
- Instruction Leaflet

**Figure 1. Package contents for the fiber optic card**

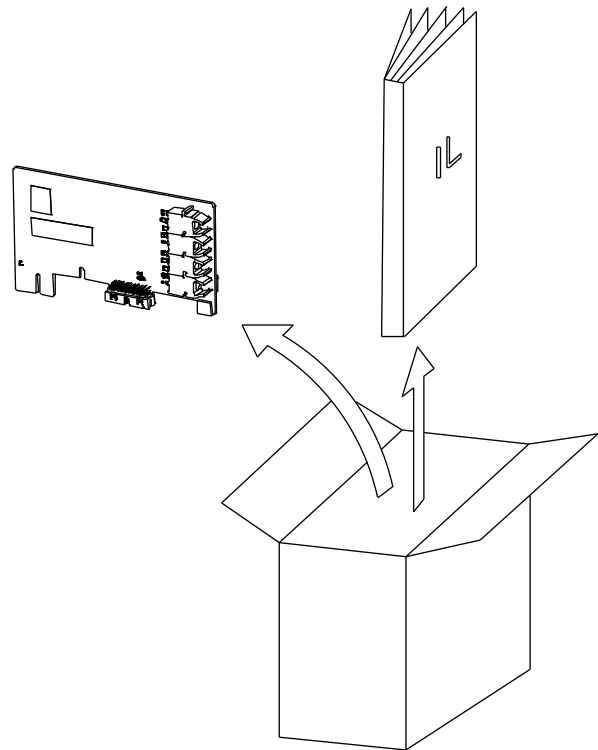

Make sure that the part number indicated on the package corresponds with the catalog number on your order. If shipping damage has occurred, please contact and file a claim with the carrier involved immediately. If the delivery does not correspond to your order, please contact your Eaton Electrical representative.

# PowerXL fiber optic option card overview

## Option card slot compatibility

PowerXL DX1 has 4 option slots (A, B, C and D) but there is a slot compatibility matrix in place. The figure below shows the orientation of the option card slots.

**Figure 2. PowerXL DX1 option card slots A, B, C, D orientation**

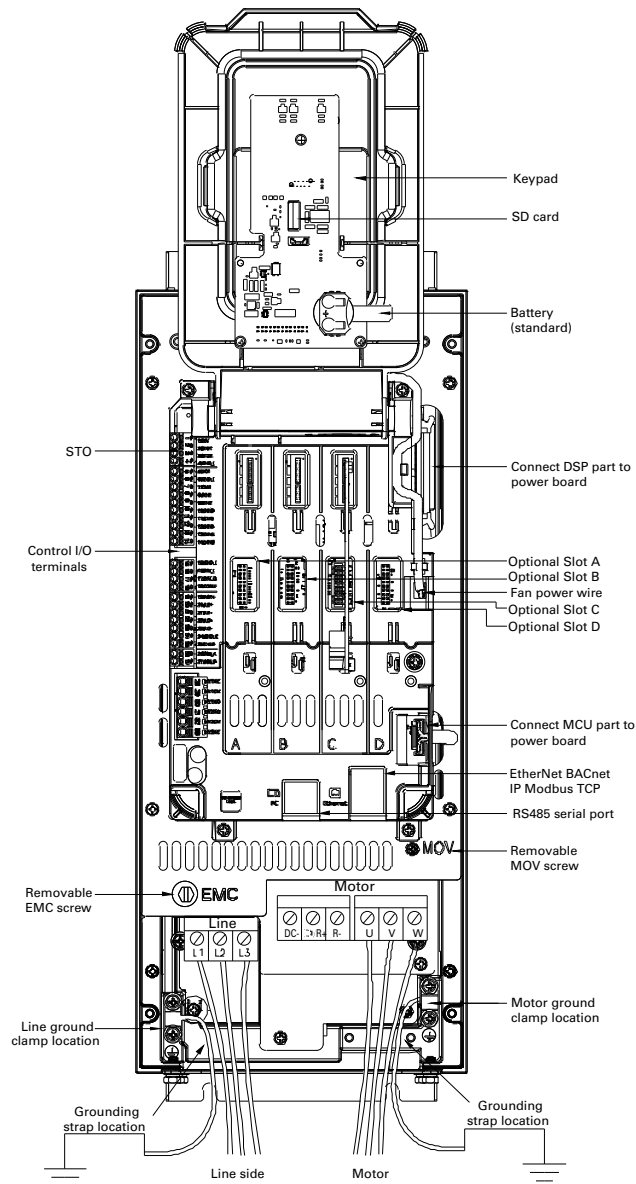

The table below shows the option cards and their slot compatibility.

Option cards	Description	Slot position
DXX-EXT-3DI3D01T	I01—3 x DI, 3 x DO, 1 x Thermistor, 24 Vdc/EXT option card	Slot A/B/C/D
DXX-EXT-1AI2A0	I02—1 x AI, 2 x AO option card	Slot A/B/C/D
DXX-EXT-3R0	I03—3 x Relay dry contact (2NO + 1NO/NC) option card	Slot A/B/C/D
DXX-EXT-THER1	I04—3 x PT100 RTD thermistor input option card	Slot A/B/C/D
DXX-EXT-6DI	I05—6 x DI 120 Vac / 240 Vac input option card	Slot A/B/C/D
DXX-EXT-ABZ	PowerXL DX1 ABZ Encoder Card	Slot A
DXX-EXT-FS	PowerXL DX1 Functional Safety Card	Slot B
DXX-NET-EIP	PowerXL DX1 Dual-Port EIP Card	Slot D
DXX-NET-PROFINET	PowerXL DX1 Dual-Port ProfiNet Card	Slot D
<b>DXX-EXT-OF</b>	<b>PowerXL DX1 Fiber Optic Card</b>	<b>Slot C</b>

The fiber optic card shall only be installed in **Slot C** of PowerXL DX1 drive.

**⚠ WARNING**

**Installation of fiber optic card in any other slot will result in a fault condition.**

Follow these steps to install the fiber optic card in Slot C.

**Step 1:** Flip the B-cover up and stop at a specific angle (120° or 150°).

**Step 2:** The table on this page shows the option card - option slot compatibility. Make sure the fiber optic card is inserted in slot C and seated properly.

**Step 3:** Flip the B-cover down for snap fit with C-cover to fix the option cards firmly.

**Figure 3. Option cards assembly**

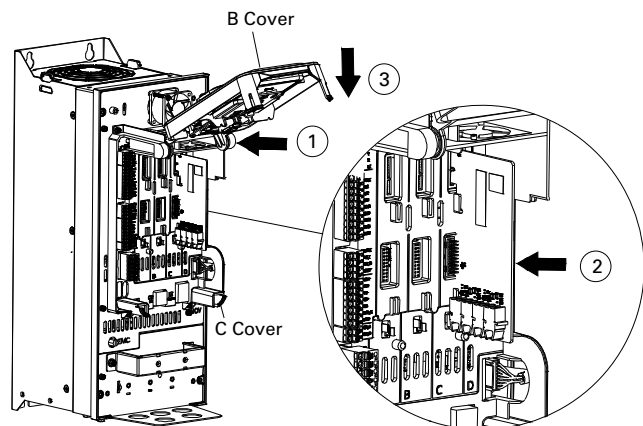

## Fiber optic card installation

### Fiber optic card connection for Master-Follower configurations

The picture below shows Master-Follower fiber optic card and cable connection for 2 or more PowerXL DX1 drives:

**Figure 4. Master-Follower fiber optic card connection**

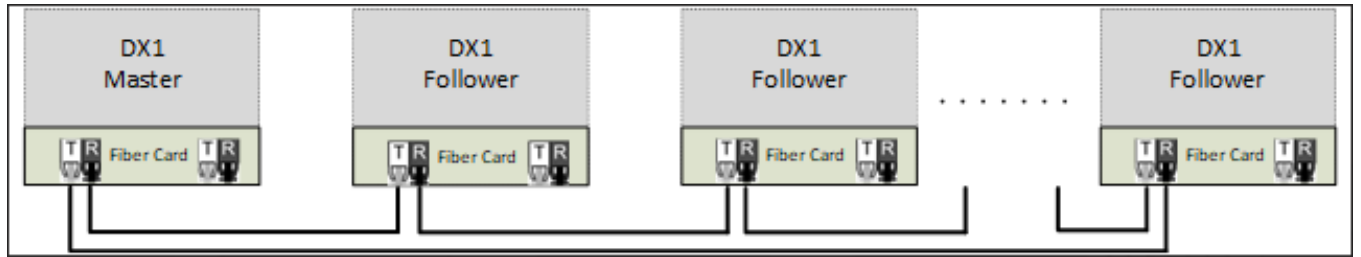

**Note:** The distance limit for each Master-Follower pair is 50 m.

**Figure 5. Two or more PowerXL DX1 drives system**

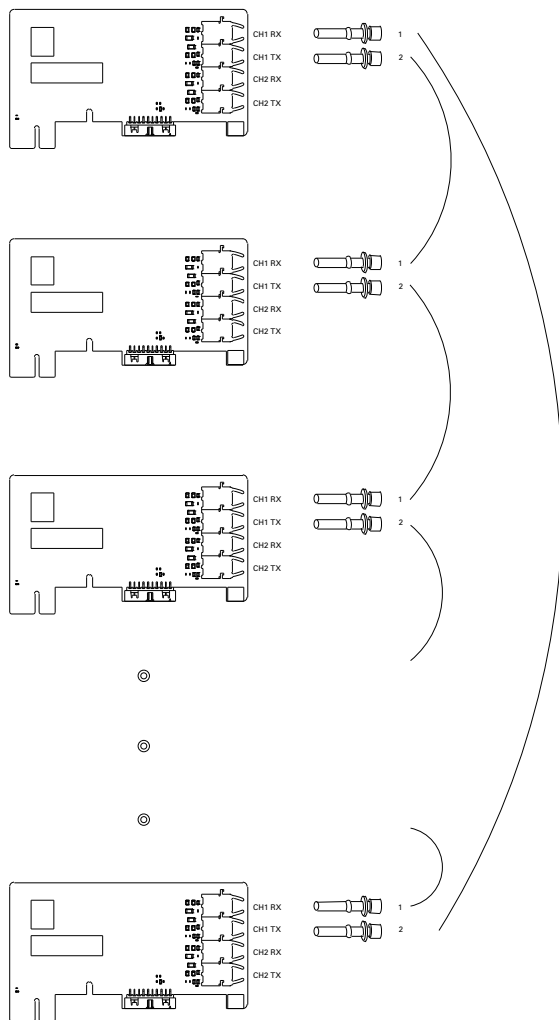

**Note:** Only CH1 is open to customers.

## Fiber optic card parameter list

### Fiber optic card parameter list

The following tables show the Master-Follower setup parameters.

**Table 1. Parameter B10.2**

Code	Parameter	Min.	Max.	Unit	Default	ID	Special note	Note
P14.1	Master Follower Mode				0	3506	①	0 = Off 1 = Master 2 = Follower
P14.2	Synchronization Mode				0	3510	①	0 = Speed Synchronization 1 = Torque Synchronization
P14.3	Communication Link				1	3511		0 = Off 1 = Fiber Optic Serial
P14.4	Speed Ratio Refresh Mode				2	3509		0 = No Action 1 = Digital Input 2 = Continuous Change
P14.5	Speed Ratio Refresh Source				0	3513	②	See Par ID 190
P14.6	Speed Error Response				0	3514		See Par ID 2813
P14.7	Speed Error Limit	0.0	100.0	%	5.0	3512		
P14.8	Speed Fault Delay	0.0	100.0	s	0.1	3515		
P14.9	Torque Ratio				1.000	3516		
P14.10	Follower Incoming Reference				5	3517		0 = Analog Input 1 1 = Analog Input 2 2 = Fieldbus Reference 3 = SlotA:Encoder 1 4 = SlotA:Encoder 2 5 = Master Reference 6 = High Freq. DI
P14.11	Follower Start Delay	0.0	3600.0	s	0.0	3518		
P14.12	Follower Stop Delay	0.0	3600.0	s	0.0	3519		
P14.13	Master Outgoing Reference				2	3520		0 = Analog Input 1 1 = Analog Input 2 2 = Master Reference 3 = Master Ramp Out 4 = SlotA:Encoder 1 5 = SlotA:Encoder 2
P14.14	M/F COMM T-OUT	5	60000	ms	100	3521		
P14.15	M/F COMM Fault Response				2	3522		See Par ID 2813
P14.16	Follower Error Response				2	3523		See Par ID 2813
P14.17	Supervision Response				0	3524		See Par ID 2813
P14.18	Limit Reached Response				0	3525		See Par ID 2813

**Table 1. Parameter B10.2, continued**

<b>Code</b>	<b>Parameter</b>	<b>Min.</b>	<b>Max.</b>	<b>Unit</b>	<b>Default</b>	<b>ID</b>	<b>Special note</b>	<b>Note</b>
P14.19	Follower Stop Mode				2	3526		0 = Coasting 1 = Ramp 2 = As Master
P14.20	Speed Ratio				1	3536		
P14.21	Speed Multiplier				1.000	3538		
P14.22	Speed Ratio Ramp Time	0	1000000	ms	10	3539		

**Note:**

1. Parameter value can only be changed after the drive has stopped.
2. Parameter value will be set to be default when changing macros.

## Master-Follower Setup

### Master-Follower Setup

Master-Follower open loop speed control and closed loop speed control are almost the same setup; the difference is only the motor control mode, and for open loop speed control also need to auto tune at Master VFD and Follower VFD. The following sections provide setup information for Master-Follower speed or torque control using fiber optic card.

### Master-Follower Speed Control Setup (Open Loop)

#### General Setup (Master VFD)

P8.1.1	Motor Control Mode	5: Open Loop Speed Control
P8.10.1	Motor Type Selection	0: Inverter Duty

#### Master-Follower Menu Setup (Master VFD)

P14.1	Master Follower Mode	1: Master
P14.2	Synchronization Mode	0: Speed Synchronization
P14.3	Communication Link	1: Fiber Optic Serial
P14.13	Master Outgoing Reference	2: Master Reference

#### General Setup (Follower VFD)

P8.1.1	Motor Control Mode	5: Open Loop Speed Control
P8.10.1	Motor Type Selection	0: Inverter Duty

#### Master-Follower Menu Setup (Follower VFD)

P14.1	Master Follower Mode	2: Follower
P14.2	Synchronization Mode	0: Speed Synchronization
P14.3	Communication Link	1: Fiber Optic Serial
P14.10	Follower Incoming Reference	5: Master Reference

#### Additional touchscreen keypad settings:

Master drive:

- Go to "Device Control Screen"
- Set control to "Local"
- Set reference to "Local Reference"

Follower drive:

- Go to "Device Control Screen"
- Set control to "Remote"

### Master-Follower Speed Control Setup (Closed Loop)

#### General Setup (Master VFD)

P8.1.1	Motor Control Mode	7: Closed Loop Speed Control
P8.10.1	Motor Type Selection	0: Inverter Duty

#### Auto Tune (Master VFD)

Motor Auto Tune must be done with the motor uncoupled (No load)

P14.1	Master Follower Mode	0: Off
P8.10.8	Identification	2: Identification With Run

Immediately go to the device control screen and press run. The motor will auto tune. When complete, continue to the next step.

#### Master-Follower Menu Setup (Master VFD)

P14.1	Master Follower Mode	1: Master
P14.2	Synchronization Mode	0: Speed Synchronization
P14.3	Communication Link	1: Fiber Optic Serial
P14.13	Master Outgoing Reference	2: Master Reference

#### General Setup (Follower VFD)

P8.1.1	Motor Control Mode	7: Closed Loop Speed Control
P8.10.1	Motor Type Selection	0: Inverter Duty

#### Auto Tune (Follower VFD)

Motor Auto Tune must be done with the motor uncoupled (No load)

P14.1	Master Follower Mode	0: Off
P8.10.8	Identification	2: Identification With Run

Immediately go to the device control screen and press run. The motor will auto tune. When complete, continue to the next step.

#### Master-Follower Menu Setup (Follower VFD)

P14.1	Master Follower Mode	2: Follower
P14.2	Synchronization Mode	0: Speed Synchronization
P14.3	Communication Link	1: Fiber Optic Serial
P14.10	Follower Incoming Reference	5: Master Reference

Device Control Screen

Set Device control to Remote.

Set Reference control to Remote.



Eaton is dedicated to ensuring that reliable, efficient and safe power is available when it's needed most. With unparalleled knowledge of electrical power management across industries, experts at Eaton deliver customized, integrated solutions to solve our customers' most critical challenges.

Our focus is on delivering the right solution for the application. But, decision makers demand more than just innovative products. They turn to Eaton for an unwavering commitment to personal support that makes customer success a top priority. For more information, **visit [www.eaton.com/electrical](http://www.eaton.com/electrical)**.

**Eaton**  
1000 Eaton Boulevard  
Cleveland, OH 44122  
United States  
[Eaton.com](http://Eaton.com)

© 2025 Eaton  
All Rights Reserved  
Printed in USA  
Publication No. MN040076EN / ZD29851  
January 2025

Eaton is a registered trademark.

All trademarks are property  
of their respective owners.

**EATON**  
*Powering Business Worldwide*