

Data Sheet | Item Number: 891-8992/115-502

pre-assembled connecting cable; Eca; Socket/open-ended; 2-pole; Cod. A; Control cable 2 x 1.0 mm²; 5 m; 1,00 mm²; white

<https://www.wago.com/891-8992/115-502>

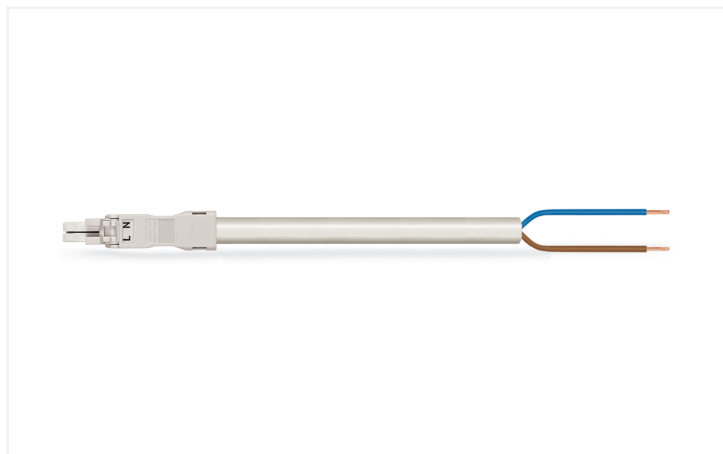

Color: ■ white

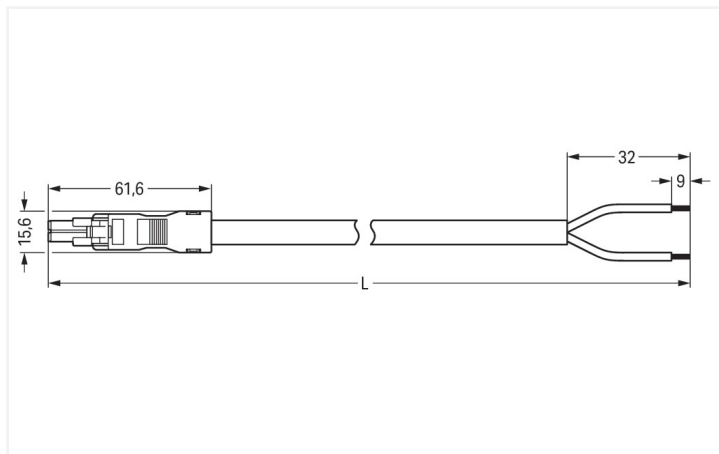

Dimensions in mm

Cable assembly WINSTA® MINI 2-pole

The WINSTA® MINI cable assembly rated current 10 A is the pluggable solution for your use in control cabinets, on PCBs or for lighting connections. WAGO pluggable installation connectors are useful when criteria repeat or are planned on a specified grid, for example for installing grid lighting or flush-mount lighting. The coding options reduce installation errors, allowing fast, secure wiring of all components. The pluggable installation connector is protected against ingress by solid granular objects with a diameter below 1 mm in accordance with protection type IP40. The WINSTA® MINI pluggable installation connector with A coding in black or white is normally used for general mains applications in power distribution. Especially if only limited space is available, our smallest pluggable connection system, WINSTA® MINI, conveniently displays its strengths. It is very compact, and, thanks to Push-in CAGE CLAMP® spring pressure connection technology, it also saves time, since the installation is low-maintenance and can be performed without screw connections. Of course, the safety of buildings must always be ensured, even after the electrical installation has been performed. The required safety requirements in connection with EU CPR are fully satisfied by this product through fire class E. Eliminating halogens as an additive in the production of this cable assembly significantly increases fire safety and minimises environmental pollution.

Pluggable connections instead of screw connections – cable assemblies from WAGO

A socket and a free end are provided. WINSTA® is the pluggable connection system that is optimally tailored to the strict requirements of electrical installation. It allows error-free installation of cables and components, quickly and reliably. Now you can also cut installation costs without compromising quality and safety: with strain relief hosting reduces the need for servicing and prevents unnecessary downtime.

- effective protection against mismatching
- easy tool-free operation, a wide range of coding options
- with A coding for a great number of uses
- custom-engineered solutions
- rapid, structured electrical installation

Notes

Note

Cables with a different fire class can be found in the eShop.

Electrical data

Ratings per	IEC/EN 60664-1		
Overvoltage category	III	III	II
Pollution degree	3	2	2
Nominal voltage	250 V	-	-
Rated impulse withstand voltage	4 kV	-	-
Rated current	10 A	-	-

General information

Note on contact resistance	approx. 1 mΩ of contact resistance approx. 0.25 mΩ contact transition plug/ socket
----------------------------	--

Connection Data

Total number of potentials	2
Conductor preparation	ultrasonically tip-bonded

Connection 1

Strip length	9 mm / 0.35 inches
Pole number	2
Wire cross-section	1 mm ²
Strip length (outer insulation)	32 mm
Connection type	Socket - free end

Physical data

Pin spacing	4.4 mm / 0.173 inches
Width	15.6 mm / 0.614 inches
Height	13.2 mm / 0.52 inches
Total length	5 m

Mechanical data

Use	General mains applications
Coding	A
Variable coding	No
Marking	L N
Potential marking	L N
Mating force of a plug-in connection	approx. 20 ... 70 N (depending on pole number)
Retention force of a plug-in connection	when locked: > 80N
Unmating force of a plug-in connection	when unlocked: approx. 20 ... 70 N (depending on pole number)
Number of mating cycles	200, without resistive load
Connection type	Socket - free end
Type of pre-assembled cable	Connecting cable
Cable type	H05Z1Z1-F 2x1
Protection type	IP40

Plug-in connection

Mismating protection	Yes
Note on mismating protection	All <i>WINSTA</i> ® components are 100% protected against mismating when: a.) plugging different numbers of poles b.) plugging while rotated 180 c.) plugging while laterally staggered d.) plugging one pole
Locking lever	Can be retrofitted
Locking of plug-in connection	Locking lever
Note on locking system	All connectors for mounted installations (snap-in versions for lighting fixtures or devices, all types of PCB and distribution connectors) are factory-equipped with locking levers to ensure plugs and sockets are securely locked. Additional locking levers are only required for flying leads (plug/socket).

Material data

Note (material data)	Information on material specifications can be found here
Color	white
Insulation material (main housing)	Polyamide (PA66)
Fire class per EN 50575	E _{ca}
Contact material	Copper or copper alloy; surface-treated
Contact Plating	Tin
Fire load	149.698 MJ
Connector color	white
Strain relief color	white
Sheathed cable color	white
Printing color of sheathed cable	black
Halogen-free	Yes
Silicon-free	Yes
Sheath material	Halogen-free
Rubber cable	No
Weight	289.9 g
Copper weight of the raw cable	0.0192 kg/m

Environmental requirements

Processing temperature	-5 ... +40 °C
Continuous operating temperature	-35 ... +85 °C
Note on continuous operating temperature	Cable for temperatures ≤ 70 °C (including halogen-free) Insulating parts for temperatures ≤ 105 °C

Commercial data

PU (SPU)	1 pcs
Packaging type	unpacked
Country of origin	PL
GTIN	4055143392419
Customs tariff number	85444290900

Product Classification

UNSPSC	26121629
eCl@ss 10.0	27-44-06-04
eCl@ss 9.0	27-44-06-04
ETIM 9.0	EC002587
ETIM 10.0	EC002587
ECCN	NO US CLASSIFICATION

Environmental Product Compliance

RoHS Compliance Status	Compliant, No Exemption
------------------------	-------------------------

Downloads

Environmental Product Compliance

Compliance Search

Environmental Product Compliance
891-8992/115-502



Documentation

Bid Text

891-8992/115-502	19.02.2019	xml 3.01 KB	
891-8992/115-502	21.11.2014	doc 24.00 KB	

CAD/CAE-Data

CAE data

EPLAN Data Portal
891-8992/115-502



WSCAD Universe
891-8992/115-502



1 Compatible Products

1.1 Required Accessories

1.1.1 Locking system

1.1.1.1 Locking system



[Item No.: 890-111](#)

Locking lever; for flying leads; for tool operation; black

[Item No.: 890-131](#)

Locking lever; for flying leads; for tool operation; white

[Item No.: 890-101](#)

Locking lever; for manual operation; black

[Item No.: 890-121](#)

Locking lever; for manual operation; white

1.2 Optional Accessories

1.2.1 Cover

1.2.1.1 Cover



[Item No.: 897-2001](#)

Protective cap; Type1; for sockets and plugs; PVC; red

1.2.2 Installation

1.2.2.1 Mounting accessories



Item No.: [890-310](#)

Mounting carrier; 2- to 5-pole; for flying leads; black



Item No.: [890-311](#)

Mounting carrier; 2- to 5-pole; for flying leads; white