

## Data Sheet | Item Number: 891-8994/106-202

pre-assembled connecting cable; Eca; Socket/open-ended; 4-pole; Cod. A; H05VV-F 4G 1.5 mm<sup>2</sup>; 2 m; 1,50 mm<sup>2</sup>; white

<https://www.wago.com/891-8994/106-202>

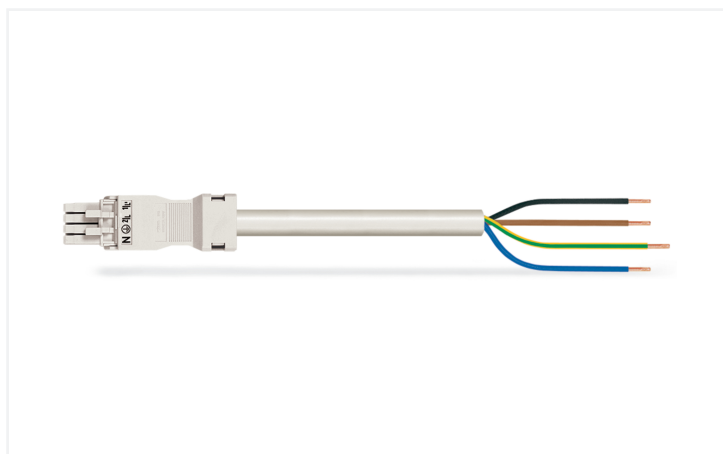

Color: ■ white

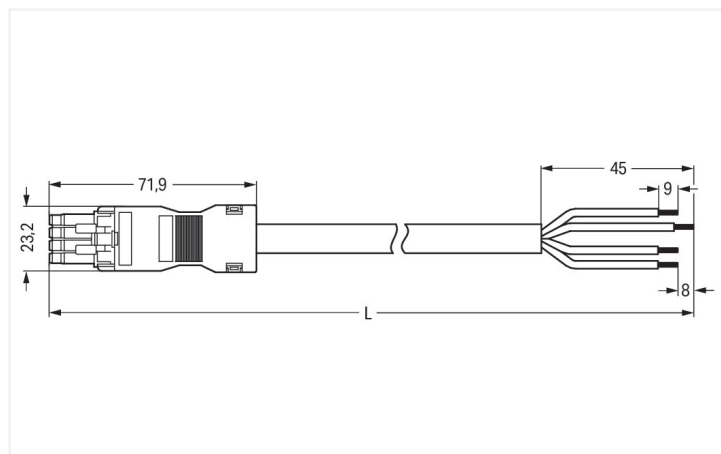

Dimensions in mm

### Cable assembly WINSTA® MINI 4-pole

The WINSTA® MINI cable assembly A coding provides the foundation for assembly of fine-stranded and solid conductors. The pluggable installation connectors with spring pressure connection technology work entirely without screw connections. They allow flexible, error-free installation in a large number of applications. For greater protection in electrical installations, the pluggable installation connector is equipped with mechanical protection against mismatching. The pluggable installation connector is protected against ingress by solid granular objects with a diameter below 1 mm in accordance with protection type IP40. Thanks to the color coding and mechanical A coding of WINSTA® MINI pluggable installation connectors, you can clearly distinguish different circuits. WINSTA® MINI follows the trend towards miniaturisation. Our smallest pluggable connection system is especially suitable for lights, for instance, since due to LED technology, these offer less and less space for the connection technology. This product meets all the relevant safety requirements of fire class E; thus it can be used in areas where fire safety is relevant.

### Fast, secure pluggable connections – cable assemblies from WAGO

The cable assembly is equipped with a socket and a free end. WINSTA® is the pluggable connection system that is perfectly tailored to the strict requirements of electrical installation. It ensures error-free installation of cables and components, quickly and reliably. Now you can also cut installation costs without compromising quality and safety: with marking reduces the need for servicing and prevents unnecessary downtime.

- effective protection against mismatching
- compact design for conductors with a cross-section up to 1.5 mm<sup>2</sup>
- suitable for any application
- flexible installation to save space
- quick replacement of defective units during ongoing operation

### Notes

Note Cables with a different fire class can be found in the eShop.

### Electrical data

Ratings per	IEC/EN 60664-1		
Overvoltage category	III	III	II
Pollution degree	3	2	2
Nominal voltage	400 V	-	-
Rated impulse withstand voltage	6 kV	-	-
Rated current	16 A	-	-

### General information

Note on contact resistance approx. 1 mΩ of contact resistance  
approx. 0.25 mΩ contact transition plug/  
socket

## Connection Data

Total number of potentials	4
PE function	Preceding PE contact
Conductor preparation	ultrasonically tip-bonded

### Connection 1

Strip length	9 mm / 0.35 inches
Pole number	4
Wire cross-section	1.5 mm <sup>2</sup>
Strip length (outer insulation)	45 mm
Connection type	Socket - free end

## Physical data

Pin spacing	4.4 mm / 0.173 inches
Width	23.2 mm / 0.913 inches
Height	16 mm / 0.63 inches
Total length	2 m

## Mechanical data

Use	General mains applications
Coding	A
Variable coding	No
Marking	N ⊕ 2/L 1/L'
Potential marking	N ⊕ 2/L 1/L'
Mating force of a plug-in connection	approx. 20 ... 70 N (depending on pole number)
Retention force of a plug-in connection	when locked: > 80N
Unmating force of a plug-in connection	when unlocked: approx. 20 ... 70 N (depending on pole number)
Number of mating cycles	200, without resistive load
Connection type	Socket - free end
Type of pre-assembled cable	Connecting cable
Cable type	H05VV-F 4G1.5
Protection type	IP40

## Plug-in connection

Mismating protection	Yes
Note on mismating protection	All <i>WINSTA</i> ® components are 100% protected against mismating when: a.) plugging different numbers of poles b.) plugging while rotated 180 c.) plugging while laterally staggered d.) plugging one pole
Locking lever	Can be retrofitted
Locking of plug-in connection	Locking lever
Note on locking system	All connectors for mounted installations (snap-in versions for lighting fixtures or devices, all types of PCB and distribution connectors) are factory-equipped with locking levers to ensure plugs and sockets are securely locked. Additional locking levers are only required for flying leads (plug/socket).

## Material data

Note (material data)	<a href="#">Information on material specifications can be found here</a>
Color	white
Insulation material (main housing)	Polyamide (PA66)
Fire class per EN 50575	E <sub>ca</sub>
Contact material	Copper or copper alloy; surface-treated
Contact Plating	Tin
Fire load	59.941 MJ
Connector color	white
Strain relief color	white
Sheathed cable color	white

### Material data

Printing color of sheathed cable	black
Halogen-free	No
Silicon-free	Yes
Sheath material	PVC
Rubber cable	No
Weight	269.4 g
Copper weight of the raw cable	0.058 kg/m

### Environmental requirements

Processing temperature	-5 ... +40 °C
Continuous operating temperature	-35 ... +85 °C
Note on continuous operating temperature	Cable for temperatures ≤ 70 °C (including halogen-free) Insulating parts for temperatures ≤ 105 °C

### Commercial data

PU (SPU)	1 pcs
Packaging type	unpacked
Country of origin	PL
GTIN	4055143404280
Customs tariff number	85444290900

### Product Classification

UNSPSC	26121629
eCl@ss 10.0	27-44-06-04
eCl@ss 9.0	27-44-06-04
ETIM 9.0	EC002587
ETIM 10.0	EC002587
ECCN	NO US CLASSIFICATION

### Environmental Product Compliance

RoHS Compliance Status	Compliant, No Exemption
------------------------	-------------------------

### Approvals / Certificates

#### General approvals



Approval	Standard	Certificate Name
CCA DEKRA Certification B.V.	EN 61535	NTR NL-7971
KEMA/KEUR DEKRA Certification B.V.	EN 61535	71-123232

Downloads

Environmental Product Compliance

Compliance Search

Environmental Product Compliance  
891-8994/106-202



Documentation

Bid Text

891-8994/106-202	19.02.2019	xml 2.98 KB	
891-8994/106-202	01.12.2014	doc 24.50 KB	

CAD/CAE-Data

CAE data

EPLAN Data Portal 891-8994/106-202	
WSCAD Universe 891-8994/106-202	

1 Compatible Products

1.1 Required Accessories

1.1.1 Locking system

1.1.1.1 Locking system



[Item No.: 890-111](#)  
Locking lever; for flying leads; for tool operation; black

[Item No.: 890-131](#)  
Locking lever; for flying leads; for tool operation; white

[Item No.: 890-101](#)  
Locking lever; for manual operation; black

[Item No.: 890-121](#)  
Locking lever; for manual operation; white

1.2 Optional Accessories

1.2.1 Cover

1.2.1.1 Cover



[Item No.: 897-2003](#)  
Protective cap; Type2; for sockets and plugs; PVC; red

## 1.2.2 Installation

### 1.2.2.1 Mounting accessories



Item No.: 890-310

Mounting carrier; 2- to 5-pole; for flying leads; black



Item No.: 890-311

Mounting carrier; 2- to 5-pole; for flying leads; white