

Data Sheet | Item Number: 891-8992/116-101

pre-assembled connecting cable; Eca; Socket/open-ended; 2-pole; Cod. A;
H05Z1Z1-F 2 x 1,50 mm²; 1 m; 1,50 mm²; black

<https://www.wago.com/891-8992/116-101>

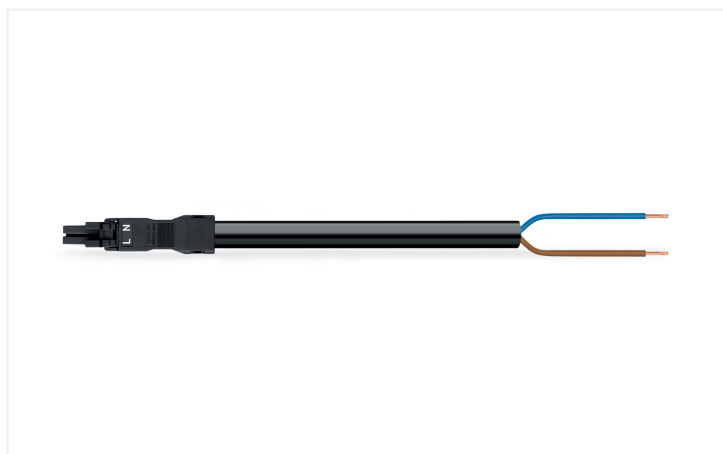

Color: ■ black

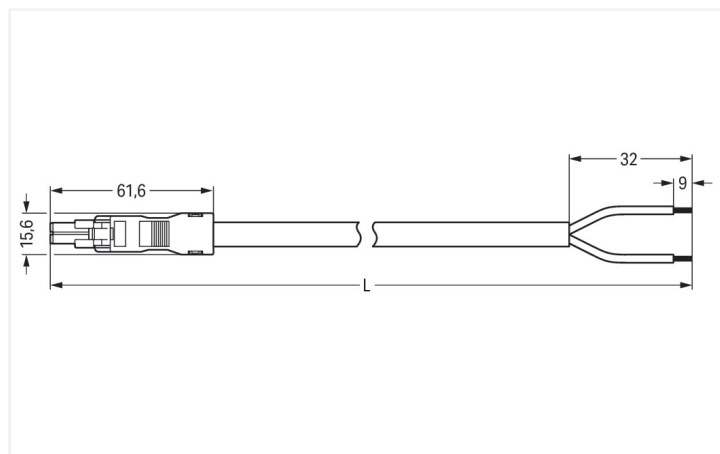

Dimensions in mm

Cable assembly WINSTA® MINI with protection type IP40

Use effective pluggable connections instead of laborious screw connections: With the WINSTA® MINI cable assembly A coding, WAGO pluggable installation connectors can be used when requirements repeat or are planned on a specific pattern, for example for installing grid lighting or flush-mount lighting. The coding options reduce installation errors, allowing fast, secure wiring of all components. The pluggable installation connector is protected against ingress by solid granular objects with a diameter below 1 mm in accordance with protection type IP40. Thanks to the color coding and mechanical A coding of WINSTA® MINI pluggable installation connectors, you can clearly distinguish different circuits. Due to its particularly compact dimensions, our WINSTA® MINI Pluggable Connection System with Push-in CAGE CLAMP® spring pressure connection technology is especially suitable in very restricted spaces, i.e., for installations when very little room is available. According to the European CPR, the fire class of the cables used in construction is essential for the safety of buildings, too. For buildings with average safety requirements, cable assemblies with fire class E are suitable. Not using halogen additives in the manufacture of this cable assembly substantially increases fire safety and minimises environmental pollution.

Fast, error-free assembly thanks to cable assemblies from WAGO

The cable assembly is provided with a socket and a free end. WINSTA® is the pluggable connection system that is ideally tailored to the strict requirements of electrical installation. It ensures error-free installation of cables and components, quickly and reliably. Choose quality and durability – with protection against mismatching from WAGO makes the electrical installation of electrical components significantly easier.

- effective protection against mismatching
- compact design for conductors with a cross-section up to 1.5 mm²
- with A coding for use in a large number of general mains applications
- custom-engineered solutions
- convenient installation and commissioning

Notes

Note

Cables with a different fire class can be found in the eShop.

Electrical data

| Ratings per | IEC/EN 60664-1 | | |
|---------------------------------|----------------|-----|----|
| Overvoltage category | III | III | II |
| Pollution degree | 3 | 2 | 2 |
| Nominal voltage | 250 V | - | - |
| Rated impulse withstand voltage | 4 kV | - | - |
| Rated current | 16 A | - | - |

General information

| | |
|----------------------------|---|
| Note on contact resistance | approx. 1 mΩ of contact resistance approx. 0.25 mΩ contact transition plug/ socket |
|----------------------------|---|

Connection Data

| | |
|----------------------------|---------------------------|
| Total number of potentials | 2 |
| Conductor preparation | ultrasonically tip-bonded |

Connection 1

| | |
|---------------------------------|---------------------|
| Strip length | 9 mm / 0.35 inches |
| Pole number | 2 |
| Wire cross-section | 1.5 mm ² |
| Strip length (outer insulation) | 32 mm |
| Connection type | Socket - free end |

Physical data

| | |
|--------------|------------------------|
| Pin spacing | 4.4 mm / 0.173 inches |
| Width | 15.6 mm / 0.614 inches |
| Height | 13.2 mm / 0.52 inches |
| Total length | 1 m |

Mechanical data

| | |
|---|---|
| Use | General mains applications |
| Coding | A |
| Variable coding | No |
| Marking | L N |
| Potential marking | L N |
| Mating force of a plug-in connection | approx. 20 ... 70 N (depending on pole number) |
| Retention force of a plug-in connection | when locked: > 80N |
| Unmating force of a plug-in connection | when unlocked: approx. 20 ... 70 N (depending on pole number) |
| Number of mating cycles | 200, without resistive load |
| Connection type | Socket - free end |
| Type of pre-assembled cable | Connecting cable |
| Cable type | H05Z1Z1-F 2x1.5 |
| Protection type | IP40 |

Plug-in connection

| | |
|-------------------------------|--|
| Mismating protection | Yes |
| Note on mismating protection | All <i>WINSTA</i> ® components are 100% protected against mismating when: a.) plugging different numbers of poles b.) plugging while rotated 180 c.) plugging while laterally staggered d.) plugging one pole |
| Locking lever | Can be retrofitted |
| Locking of plug-in connection | Locking lever |
| Note on locking system | All connectors for mounted installations (snap-in versions for lighting fixtures or devices, all types of PCB and distribution connectors) are factory-equipped with locking levers to ensure plugs and sockets are securely locked. Additional locking levers are only required for flying leads (plug/socket). |

Material data

| | |
|------------------------------------|--|
| Note (material data) | Information on material specifications can be found here |
| Color | black |
| Insulation material (main housing) | Polyamide (PA66) |
| Fire class per EN 50575 | E _{ca} |
| Contact material | Copper or copper alloy; surface-treated |
| Contact Plating | Tin |
| Fire load | 29.636 MJ |
| Connector color | black |
| Strain relief color | black |
| Sheathed cable color | black |
| Printing color of sheathed cable | white |
| Halogen-free | Yes |
| Silicon-free | Yes |
| Sheath material | Halogen-free |
| Rubber cable | No |
| Weight | 82.7 g |
| Copper weight of the raw cable | 0.029 kg/m |

Environmental requirements

| | |
|--|---|
| Processing temperature | -5 ... +40 °C |
| Continuous operating temperature | -35 ... +85 °C |
| Note on continuous operating temperature | Cable for temperatures ≤ 70 °C (including halogen-free) Insulating parts for temperatures ≤ 105 °C |

Commercial data

| | |
|-----------------------|---------------|
| PU (SPU) | 1 pcs |
| Packaging type | unpacked |
| Country of origin | PL |
| GTIN | 4055143520799 |
| Customs tariff number | 85444290900 |

Product Classification

| | |
|-------------|----------------------|
| UNSPSC | 26121629 |
| eCl@ss 10.0 | 27-44-06-04 |
| eCl@ss 9.0 | 27-44-06-04 |
| ETIM 9.0 | EC002587 |
| ETIM 10.0 | EC002587 |
| ECCN | NO US CLASSIFICATION |

Environmental Product Compliance

| | |
|------------------------|-------------------------|
| RoHS Compliance Status | Compliant, No Exemption |
|------------------------|-------------------------|

Downloads

Environmental Product Compliance

Compliance Search

Environmental Product Compliance
891-8992/116-101



Documentation

Bid Text

| | | | |
|------------------|------------|-----------------|--|
| 891-8992/116-101 | 19.02.2019 | xml 3.02 KB | |
| 891-8992/116-101 | 21.11.2014 | doc 24.50 KB | |

CAD/CAE-Data

CAE data

EPLAN Data Portal
891-8992/116-101



WSCAD Universe
891-8992/116-101



1 Compatible Products

1.1 Required Accessories

1.1.1 Locking system

1.1.1.1 Locking system



[Item No.: 890-111](#)

Locking lever; for flying leads; for tool operation; black



[Item No.: 890-131](#)

Locking lever; for flying leads; for tool operation; white



[Item No.: 890-101](#)

Locking lever; for manual operation; black



[Item No.: 890-121](#)

Locking lever; for manual operation; white

1.2 Optional Accessories

1.2.1 Cover

1.2.1.1 Cover



[Item No.: 897-2001](#)

Protective cap; Type1; for sockets and plugs; PVC; red

1.2.2 Installation

1.2.2.1 Mounting accessories



Item No.: 890-310

Mounting carrier; 2- to 5-pole; for flying leads; black



Item No.: 890-311

Mounting carrier; 2- to 5-pole; for flying leads; white