

FOR RECYCLING PURPOSES ONLY

Disassembly Instructions

Motorized switch-disconnectors OTM315–400



Table of contents

003	Important information
004–005	Disassembly of the motorized switch- disconnecter
006	Disassembly of the mechanism II
007	Disassembly of the handle kit
008	Disassembly of the switch-disconnector
009–010	Disassembly of the pole
011	Disassembly of the mechanism I
012–014	Component list
015	Recycling information in accordance with the WEEE

Important information

This document shows the disassembly process of OTM315–400 motorized switch-disconnectors. Accessories, such as shafts, clamps, shrouds, neutral links and auxiliary contacts are not included. **Note! This document is for recycling purposes only.**

Safety Notes

Before starting the disassembly process it is mandatory to put the motorized switch-disconnector in open position.

Disassembly of motorized switch-disconnectors must be performed by qualified and skilled personnel in the electrical field (IEV 195-04-01: person with relevant education and experience to enable him or her to perceive risks and to avoid hazards which electricity can create) and having a detailed knowledge of motorized switch-disconnectors.

Disassembly must be done in an ergonomic workspace which can ensure the protection of the person doing the disassembling.

Applicable national legislation and international standards in force at the time of the disassembly of the motorized switch-disconnectors must be taken into account in addition to the prescriptions illustrated in this document.

ABB declines any responsibility for injury to people or damage to property resulting from a failure to comply with the instructions set out in this document and with any applicable safety standard.

Personal Protective Equipment (PPE)

When doing the disassembling following safety Personal Protective Equipment (PPE) must be worn:

Glasses



Gloves



Safety shoes



Protective clothes



Tools

The disassembly process requires the use of tools (e.g. screwdriver, torx key, pliers). Tools to be used are specified inside each phase of the disassembly process.

Disassembly process

For each phase of the disassembly process the following information is provided:

- Part/parts to be disassembled (title of the phase)
- Tools to be used
- Description of actions to be performed
- Pictures showing actions to be performed
- List, quantity and picture of disassembled parts with an indication about separate treatment (when applicable)
- In case of potential hazards signal below is reported:



Disassembly of the motorized switch-disconnector

Phase 1,2,3,4,5 – End plates, mounting plates, top cover, handle kit

1. Use a torx key (size 20) to unscrew the 4 screws fixing end plate and mounting plate to the motor operator.

2. Use a torx key (size 20) to unscrew the 2 screws fixing end plate, mounting plate and contact guide support to the switch-disconnector.

3. Use a torx key (size 20) to unscrew the 2 screws fixing end plate and mounting plate to the switch-disconnector.

4. Remove the top cover of the motor operator with the help of a flat screwdriver.

5. Separate the handle kit from the mechanism II (see instructions on the page 7).

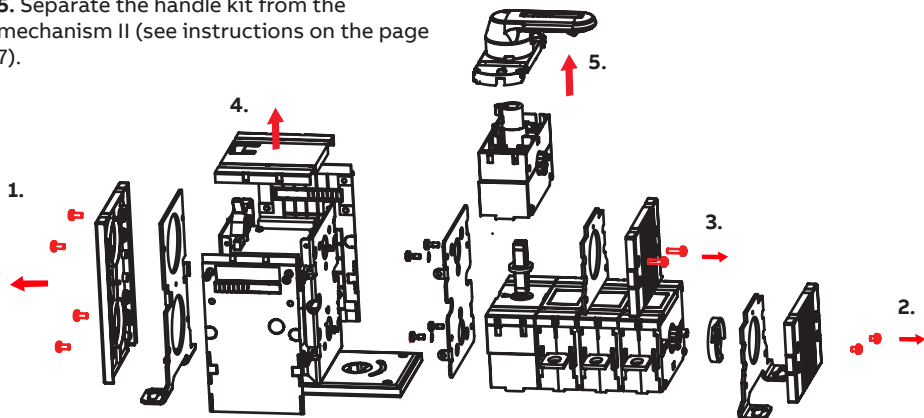

Tools

Torx key (size 20)

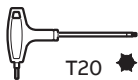

Flat screwdriver



Disassembled parts

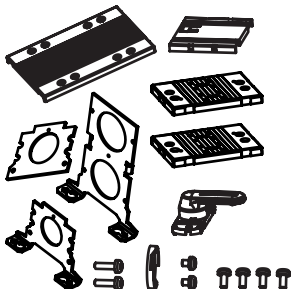

- 1 mounting plate
- 1 end plate
- 1 contact guide support
- 2 screws
- 1 mounting plate
- 1 end plate
- 4 screws
- 1 mounting plate
- 1 end plate
- 2 screws
- 1 top cover
- 1 handle kit

Phase 6,7,8,9,10 – Mechanism II, side covers, motor operator, assembling plate

6. Use pliers to separate circlip and transmission shaft from the motor operator.

7. Use a torx key (size 20) to unscrew the 4 screws fixing the side covers to the motor operator.

8. Unscrew the 4 screws fixing the assembling plate to the motor operator.

9. Unscrew the 4 screws fixing the assembling plate to the switch-disconnector.

10. Separate mechanism II and connecting part from the switch-disconnector manually.

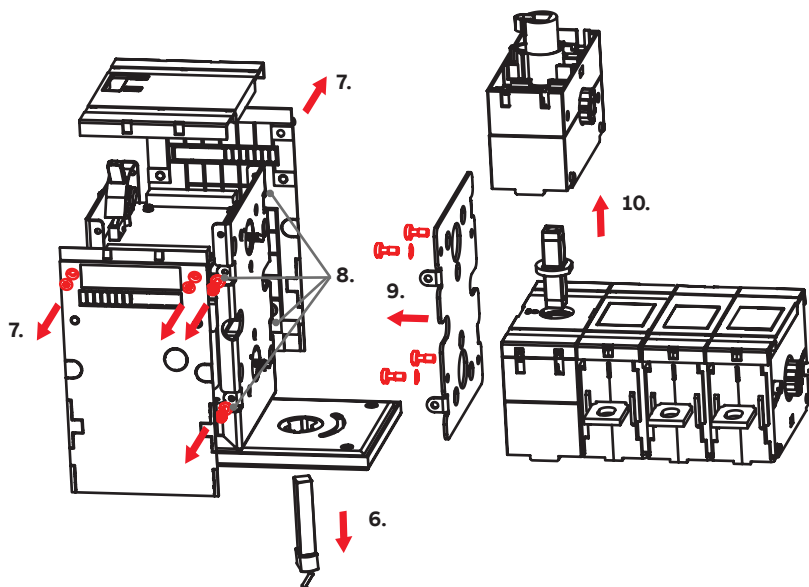

Tools

Torx key (size 20)

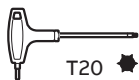

Pliers

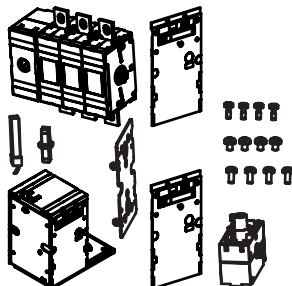

Disassembled parts

- 1 connecting part 6 poles
- 1 mechanism II
- 4 screws
- 4 screws
- 1 switch-disconnector
- 1 motor operator
- 1 assembling plate
- 4 screws
- 1 circlip
- 1 transmission shaft

Disassembly of the mechanism II

1. Unscrew the 4 screws with a torx key to remove the upper frame.

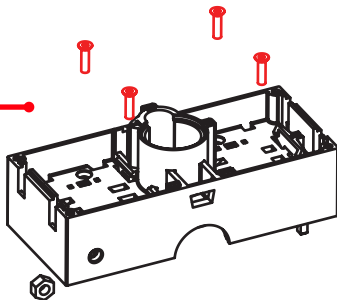

2. Remove contact guide support and two steel nuts manually.



3. Remove the lever.

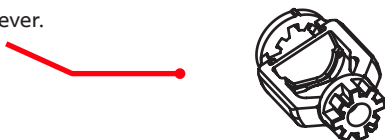

4. Remove pipesaft, lever, rhythm spring and two steel hex nuts.

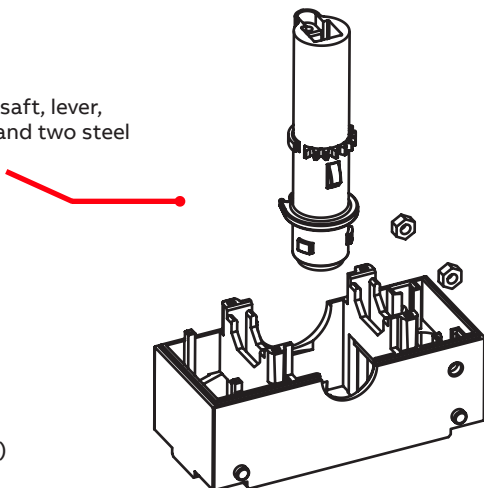

Tools

Torx key (size 8)

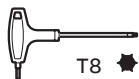

Disassembled parts

- Frame
- 4 steel hex nuts
- Lever
- Pipeshaft
- Lever
- Rhythm spring
- Frame
- 4 screws
- Contact guide support

Disassembly of the handle kit

Phase 1 & 2 – Handle kit

1. Remove the handle by pressing on the clip (marked with red) and pulling the handle up.

2. Use a torx key (size 9) to unscrew the 4 screws.

3. Use a torx key (size 9) to unscrew the 1 screw. Separate the parts from each other. Use pliers if needed.

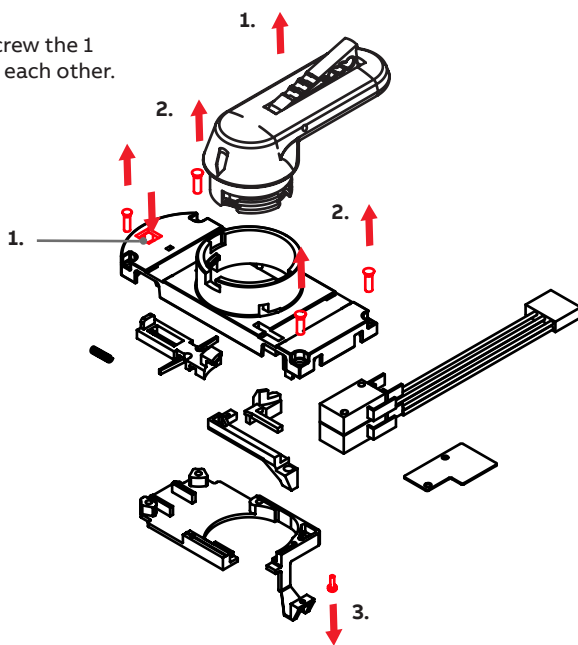

Tools

Torx key (size 9)

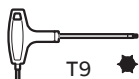

Pliers



Disassembled parts

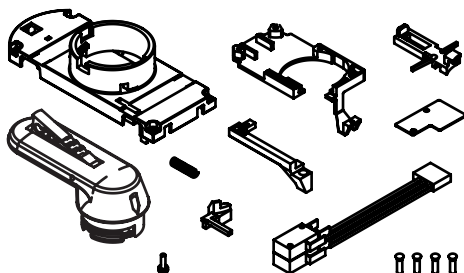

- 4 screws
- 1 screw
- 1 cover
- 1 compression spring
- 1 lock
- 1 bottom plate
- 1 mechanism for micros
- 1 locking bolt for micros
- 1 electric harness
- 1 insulator
- 1 handle

Disassembly of the switch-disconnector

Phase 1 – Stud screws

1. Use a flat screwdriver to unscrew the stud screws fixing the poles to the mechanism.

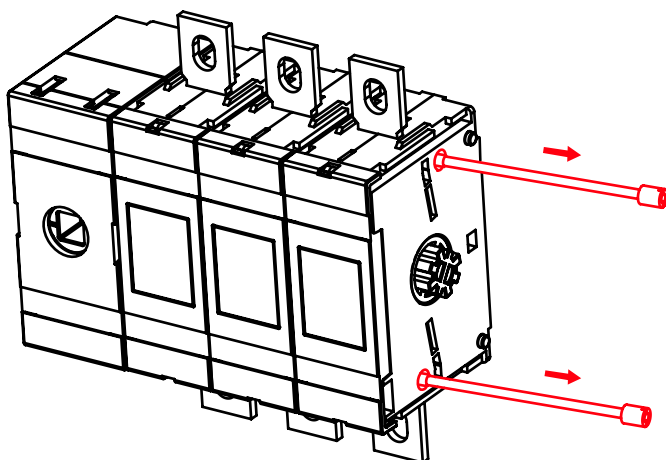

Tools

Flat screwdriver



Disassembled parts

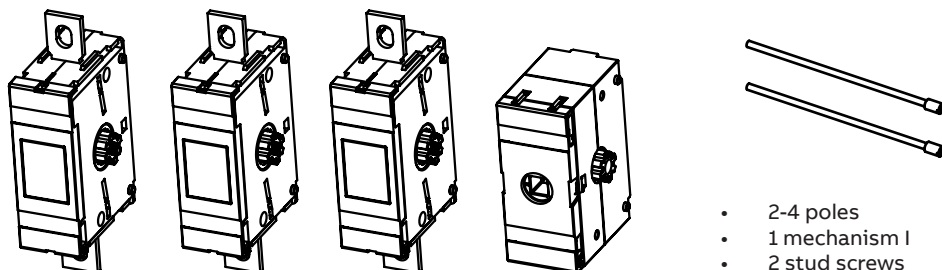

- 2-4 poles
- 1 mechanism I
- 2 stud screws

Disassembly of the pole

Phase 1 & 2 – Cover, frames and inner parts

1. Use a flat screwdriver to remove the cover.

2. Separate the frames and remove contact construction, arc plates, fixed contacts and window manually.

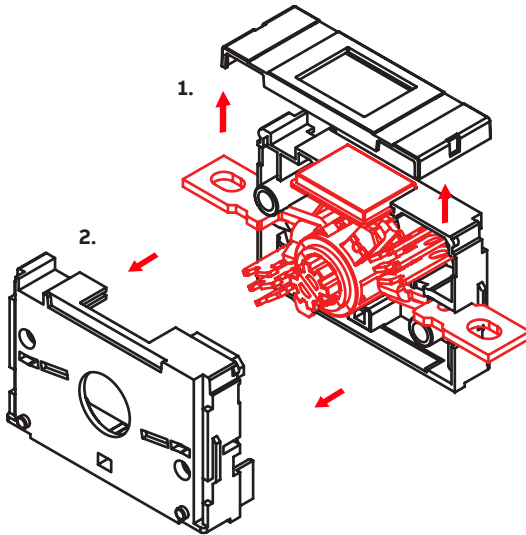

Tools

Flat screwdriver



Disassembled parts

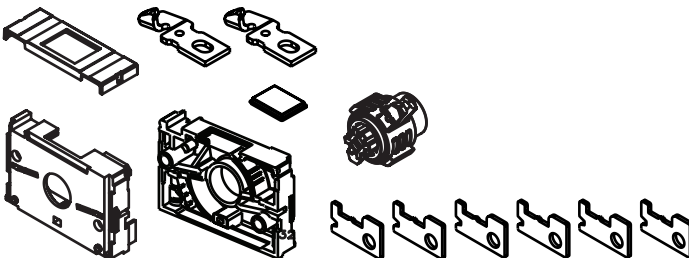

- Frame A
- Frame B
- Contact construction
- 2 fixed contacts
- 6 arc plates
- Cover
- Window



Phase 3 & 4 – Contact construction

3. Remove the knife structure from the roll manually.

4. Remove the spring guide and separate contact knives, contact springs and contact irons from each other manually.

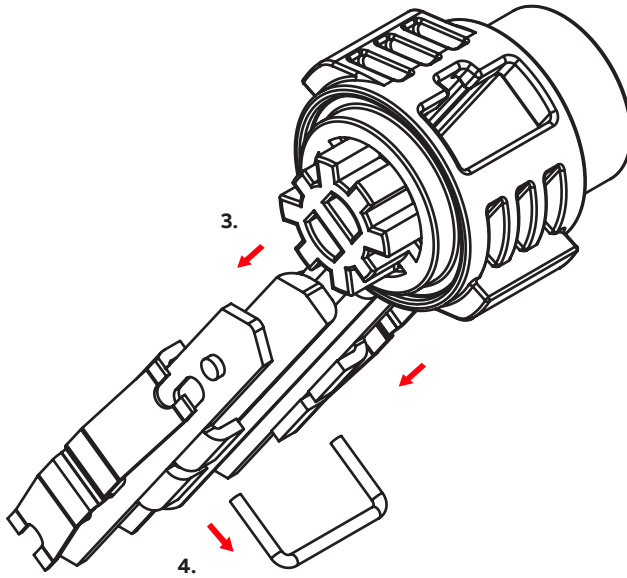

Disassembled parts

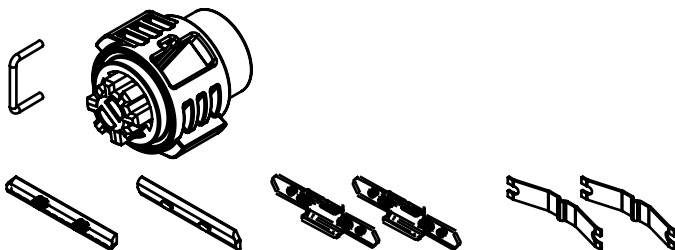

- Roll
- 1 contact knife
- 1 contact knife
- 2 contact irons
- 2 contact springs
- 1 spring guide

Disassembly of the mechanism I

1. Remove the cover with the help of a flat screwdriver.

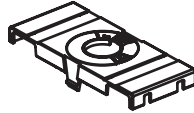

2. Unscrew the 4 screws with a torx key to remove the upper frame. Remove contact guide support and two steel nuts manually.

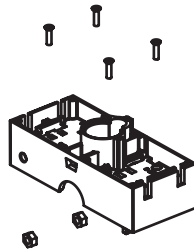

3. Remove the lever.

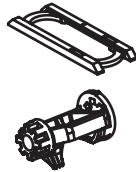

4. Remove pipesaft, lever and rhythm spring.



5. Remove the springs using pliers. Remove the two steel nuts manually.

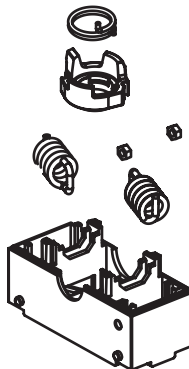

Note! Pay special attention to tensioned springs. Use personal protective equipment.

Tools

Torx key (size 8)

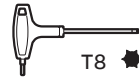

Flat screwdriver



Pliers



Disassembled parts

- Frame
- 2 springs
- 4 steel hex nuts
- Lever
- Pipeshaft
- Lever
- Rhythm spring
- Frame
- 4 screws
- Cover
- Contact guide support

Component list

Motorized switch-disconnector

Component name	Quantity	Material(s)	Weight (g/pc)
Switch-disconnector	1	See component list	2750
Motor operator	1	See component list	3974
Transmission shaft	1	Steel	20
Circlip	1	Steel	1
Connecting part 6 poles	1	Zinc	50
Mounting plate	1	Steel	200
Mounting plate	1	Steel	140
End plate	2	Polycarbonate	30
Contact guide support	1	Polyamide	8
Handle kit	1	See component list	210
Screw	2	Steel	1
Screw	2	Steel	1
Mounting plate	1	Steel	320
End plate	1	Polycarbonate	67
Screw	4	Steel	3
Mechanism II	1	See component list	530

Handle kit

Component name	Quantity	Material(s)	Weight (g/pc)
Cover	1	Polycarbonate	28
Lock	1	Polyamide	3
Compression spring	1	Steel	1
Screw	4	Steel	1
Bottom plate	1	Polycarbonate	9
Screw	1	Steel	1
Mechanism for micros	1	Polyamide	2
Locking bolt for micros	1	Polyamide	5
Insulator	1	Polycarbonate	1
Electric harness	1	Assembly	20
Handle	1	Assembly	94

—
Mechanism II

Component name	Quantity	Material(s)	Weight (g/pc)
Frame	1	Polyamide	116
Frame	1	Polyamide	74
Contact guide support	1	Polyamide	6
Pipeshaft	1	Zinc	140
Lever	1	Zinc	65
Lever	1	Zinc	89
Rhythm spring	1	Steel	36
Steel hex nut	4	Steel	1
Screw	4	Steel	1

—
Switch-disconnector

Component name	Quantity	Material(s)	Weight (g/pc)
Mechanism I	1	See component list	560
Pole	2-4	See component list	570
Stud screw	2	Steel	15-25

—
Pole

Component name	Quantity/pole	Material(s)	Weight (g/pc)
Frame A	1	Polyester	143
Frame B	1	Polyester	165
Contact knife	1	Copper	26
Contact knife	1	Copper	26
Contact iron	2	Steel	18
Contact spring	2	Steel	3
Spring guide	1	Steel	1
Roll	1	Polyamide	35
Arc plate	6	Steel	8
Fixed contact	2	Copper	103
Window	1	Polycarbonate	4
Cover	1	Polycarbonate	11

Mechanism I

Component name	Quantity	Material(s)	Weight (g/pc)
Frame	1	Polyamide	116
Frame	1	Polyamide	74
Cover	1	Polycarbonate	16
Pipeshaft	1	Zinc	140
Lever	1	Zinc	65
Lever	1	Zinc	88
Spring	2	Steel	10
Rhythm spring	1	Steel	10
Steel hex nut	4	Steel	1
Screw	4	Steel	1

Recycling information in accordance with the WEEE

The product is marked with the wheelie bin symbol. It indicates that at the end of life the product should enter the recycling system.

You should dispose of it separately at an appropriate collection point and not place it in the normal waste stream.

The figure below shows the wheelie bin symbol indicating separate collection for electrical and electronic equipment (EEE).



The horizontal bar underneath the crossed-out wheelie bin indicates that the equipment has been manufactured after the Directive came into force in 2005.

The wheelie bin symbol is added to the type designation label of the product since 2017.



Contact us

ABB Oy

P.O. Box 622
FI-65101 Vaasa
Finland

abb.com/lowvoltage