

## Data Sheet | Item Number: 771-8965/117-102

pre-assembled connecting cable; Eca; Distribution connector with phase selection/  
open-ended; 5-pole; Cod. A; H05Z1Z1-F 5G 2.5 mm<sup>2</sup>; 1 m; 2,50 mm<sup>2</sup>; white

<https://www.wago.com/771-8965/117-102>

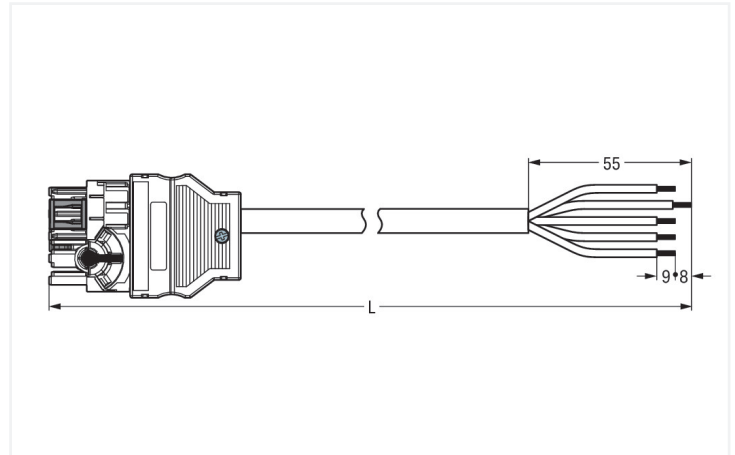
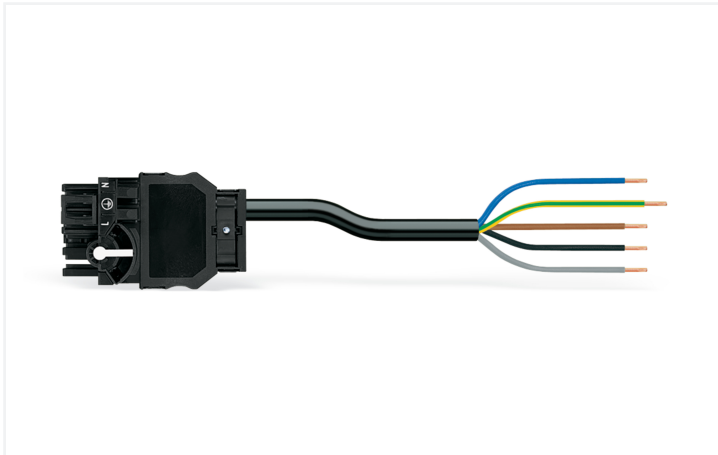

Color: ■ white

Similar to illustration

Dimensions in mm

### Cable assembly WINSTA® MIDI with protection type IP20

The WINSTA® MIDI cable assembly A coding is the pluggable solution for your application in control cabinets, for lighting connections or on PCBs. Our pluggable installation connectors with spring pressure connection technology work completely without screw connections. They allow fast, efficient, error-free installation in numerous applications. The color coding and mechanical coding of the pluggable installation connector ensure error-free installation of the individual components – including protection against mismatching. The pluggable installation connector is protected against ingress by solid objects in accordance with protection type IP20 (When mated: IP2xC (These compact connectors are not designed for use in open, easily accessible areas!)). General mains applications for almost any domain of use can be implemented with WINSTA® MIDI pluggable installation connectors with A coding. This pluggable installation connector is used for electrical currents up to 20 A. Thus the product is especially suitable for high power loads. WINSTA® MIDI with Push-in CAGE CLAMP® spring pressure connection technology is found in a broad range of individual products you can use for quick, easy and maximally flexible installation. According to the European CPR, the fire class of the cables used in construction is essential for building safety as well. For houses with medium-level safety requirements, cable assemblies with fire class E are suitable. Not using halogen additives in the production of this cable assembly noticeably increases fire safety and minimises environmental contamination.

### Fast, error-free assembly thanks to cable assemblies from WAGO

The cable is pre-assembled with a distribution connector with phase selection and a free end. WINSTA® is the pluggable connection system that is ideally tailored to the strict requirements of electrical installation. It offers error-free installation of cables and components, quickly and reliably. Now you can also reduce installation costs without compromising quality and safety: with strain relief hosting eliminates the need for servicing and prevents unnecessary downtime.

- protection against mismatching eliminates errors
- for automation controllers
- with A coding for a great number of applications
- custom-engineered solutions
- convenient installation and commissioning

## Notes

Note Cables with a different fire class can be found in the eShop.

## Electrical data

Ratings per	IEC/EN 60664-1			General information	
Overvoltage category	III	III	II	Note on contact resistance	approx. 1 mΩ of contact resistance approx. 0.25 mΩ contact transition plug/ socket
Pollution degree	3	2	2		
Nominal voltage	400 V	-	-		
Rated impulse withstand voltage	6 kV	-	-		
Rated current	20 A	-	-		

## Connection Data

Total number of potentials	5	<b>Connection 1</b>	
Conductor preparation	ultrasonically tip-bonded	Strip length	9 mm / 0.35 inches
		Pole number	5
		Wire cross-section	2.5 mm <sup>2</sup>
		Strip length (outer insulation)	55 mm
		Connection type	Distribution connector with phase selection - free end

## Connection 2

Pole number 3

## Physical data

Pin spacing	10 mm / 0.394 inches
Width	54.6 mm / 2.15 inches
Height	43.8 mm / 1.724 inches
Total length	1 m

## Mechanical data

Use	General mains applications
Coding	A
Variable coding	Yes
Marking	N ⊕ L1 L2 L3
Potential marking	N ⊕ L1 L2 L3
Mating force of a plug-in connection	approx. 20 ... 70 N (depending on pole number)
Retention force of a plug-in connection	when locked: > 80N
Unmating force of a plug-in connection	when unlocked: approx. 20 ... 70 N (depending on pole number)
Number of mating cycles	200, without resistive load
Connection type	Distribution connector with phase selection - free end
Type of pre-assembled cable	Connecting cable
Cable type	H05Z1Z1-F 5G2.5
Protection type	IP20; When mated: IP2xC (These compact connectors are not designed for use in open, easily accessible areas!)

### Plug-in connection

Mismating protection	Yes
Note on mismating protection	All WINSTA® components are 100% protected against mismating when: a.) plugging different numbers of poles b.) plugging while rotated 180 c.) plugging while laterally staggered d.) plugging one pole
Locking lever	Can be retrofitted
Locking of plug-in connection	Locking lever
Note on locking system	All connectors for mounted installations (snap-in versions for lighting fixtures or devices, all types of PCB and distribution connectors) are factory-equipped with locking levers to ensure plugs and sockets are securely locked. Additional locking levers are only required for flying leads (plug/socket).

### Material data

Note (material data)	<a href="#">Information on material specifications can be found here</a>
Color	white
Insulation material (main housing)	Polyamide (PA66)
Fire class per EN 50575	E <sub>ca</sub>
Contact material	Copper or copper alloy; surface-treated
Contact Plating	Tin
Fire load	31.11 MJ
Connector color	white
Strain relief color	white
Sheathed cable color	white
Printing color of sheathed cable	black
Halogen-free	Yes
Silicon-free	Yes
Sheath material	Halogen-free
Rubber cable	No
Weight	278.8 g

### Environmental requirements

Processing temperature	-5 ... +40 °C
Continuous operating temperature	-35 ... +85 °C
Note on continuous operating temperature	Cable for temperatures ≤ 70 °C (including halogen-free) Insulating parts for temperatures ≤ 105 °C

### Commercial data

PU (SPU)	1 pcs
Packaging type	unpacked
Country of origin	DE
GTIN	4045454781330
Customs tariff number	85444290900

### Product Classification

UNSPSC	26121629
eCl@ss 10.0	27-44-06-04
eCl@ss 9.0	27-44-06-04
ETIM 9.0	EC002587
ETIM 10.0	EC002587
ECCN	NO US CLASSIFICATION

**Environmental Product Compliance**

RoHS Compliance Status	Compliant, No Exemption
------------------------	-------------------------

**Approvals / Certificates**

**General approvals** **Declarations of conformity and manufacturer's declarations**



Approval	Standard	Certificate Name
CCA DEKRA Certification B.V.	EN 61535	NTR NL-7972
KEMA/KEUR DEKRA Certification B.V.	EN 61535	71-123834

Approval	Standard	Certificate Name
EU-Declaration of Conformity WAGO GmbH & Co. KG	-	-
UK-Declaration of Conformity WAGO GmbH & Co. KG	-	-

**Downloads**

**Environmental Product Compliance**

**Compliance Search**

Environmental Product Compliance 771-8965/117-102	↓
--	---

**Documentation**

**Bid Text**

771-8965/117-102	19.02.2019	xml 3.03 KB	↓
771-8965/117-102	12.03.2015	doc 25.00 KB	↓

**CAD/CAE-Data**

**CAE data**

EPLAN Data Portal 771-8965/117-102	↓
WSCAD Universe 771-8965/117-102	↓

## 1 Compatible Products

### 1.1 Required Accessories

#### 1.1.1 Locking system

##### 1.1.1.1 Locking system



**Item No.: 770-101**

Locking lever; for flying leads; for manual operation; black

**Item No.: 770-121**

Locking lever; for flying leads; for manual operation; white

**Item No.: 770-111**

Locking lever; for flying leads; for tool operation; black

**Item No.: 770-131**

Locking lever; for flying leads; for tool operation; white

### 1.2 Optional Accessories

#### 1.2.1 Cover

##### 1.2.1.1 Cover



**Item No.: 770-201**

Lockout cap; 12-pole, separable; for sockets; Plastic; black

**Item No.: 770-221**

Lockout cap; 12-pole, separable; for sockets; Plastic; white

#### 1.2.2 Marking

##### 1.2.2.1 Marking strip



**Item No.: 210-333**

Marking strips; as a DIN A4 sheet; Strip width 6 mm; Strip length 182 mm; plain; Self-adhesive; white

## Installation Notes



Lift jumper out of delivery position (L2) using a screwdriver and move it into the desired position.



Push down jumper in its new position (picture shows L3).

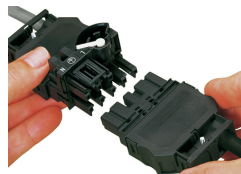

The 5-pole energy circuit can be extended using pluggable cable assemblies.

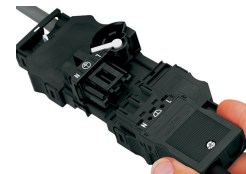

Plugging a 3-pole tap-off cable.