

FOR RECYCLING PURPOSES ONLY

Disassembly Instructions

Change-over switches OT3200_C

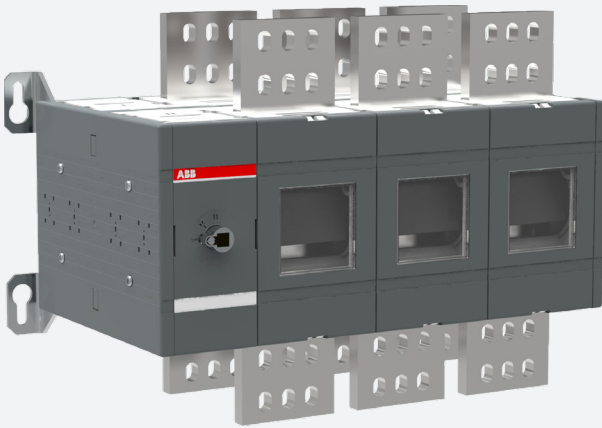

Table of contents

003	Important information
004–005	Disassembly of the change-over switch
006–008	Disassembly of the pole
009	Disassembly of the mechanism
010–011	Component list
012	Recycling information in accordance with the WEEE

Important information

This document shows the disassembly process of OT3200_C change-over switches. Accessories, such as shafts, clamps, shrouds, neutral links and auxiliary contacts are not included. **Note! This document is for recycling purposes only.**

Safety Notes

Before starting the disassembly process it is mandatory to put the change-over switch in open position.

Disassembly of change-over switches must be performed by qualified and skilled personnel in the electrical field (IEV 195-04-01: person with relevant education and experience to enable him or her to perceive risks and to avoid hazards which electricity can create) and having a detailed knowledge of change-over switches.

Disassembly must be done in an ergonomic workspace which can ensure the protection of the person doing the disassembling.

Applicable national legislation and international standards in force at the time of the disassembly of the change-over switches must be taken into account in addition to the prescriptions illustrated in this document.

ABB declines any responsibility for injury to people or damage to property resulting from a failure to comply with the instructions set out in this document and with any applicable safety standard.

Personal Protective Equipment (PPE)

When doing the disassembling following safety Personal Protective Equipment (PPE) must be worn:

Glasses



Gloves



Safety shoes



Protective clothes



Tools

The disassembly process requires the use of tools (e.g. screwdriver, torx key, pliers). Tools to be used are specified inside each phase of the disassembly process.

Disassembly process

For each phase of the disassembly process the following information is provided:

- Part/parts to be disassembled (title of the phase)
- Tools to be used
- Description of actions to be performed
- Pictures showing actions to be performed
- List, quantity and picture of disassembled parts with an indication about separate treatment (when applicable)
- In case of potential hazards signal below is reported:



Disassembly of the change-over switch

Phase 1 to 3 – End plates, mounting plates and switch-disconnectors

1. Use a torx key (size 30) to unscrew the 12 screws fixing the end plates to the switch-disconnectors.

2. Use a socket wrench (socket 13 mm) to unscrew the 8 screws fixing the mounting plates to the switch-disconnectors. Remove the 4 lockparts from the mounting plate.

3. Separate the switch-disconnectors, interm covers and contact guide supports from each other manually.

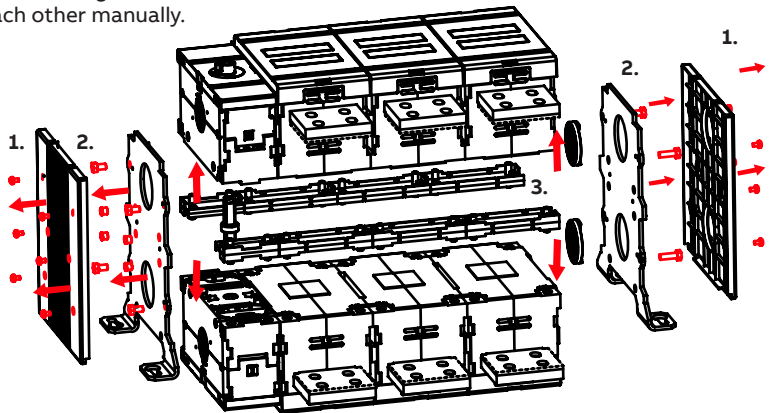

Tools

Torx key (size 30)

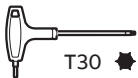

Socket wrench



socket 13 mm

Disassembled parts

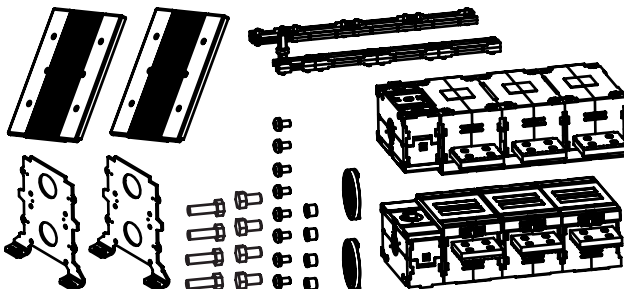

- 12 screws
- 4 steel hex screws
- 4 steel hex screws
- 4 lockparts
- 2 end plates
- 2 mounting plates
- 2 contact guide supports
- 6 interm covers
- 2 interm covers
- 2 switch-disconnectors
- 1 joint

Phase 4 & 5 – Stud screws and shaft locking

4. Use a flat screwdriver to unscrew the stud screws fixing the poles to the mechanism.

5. Remove the steel hex nut (how?).

6. Use a flat screwdriver to remove shaft locking.

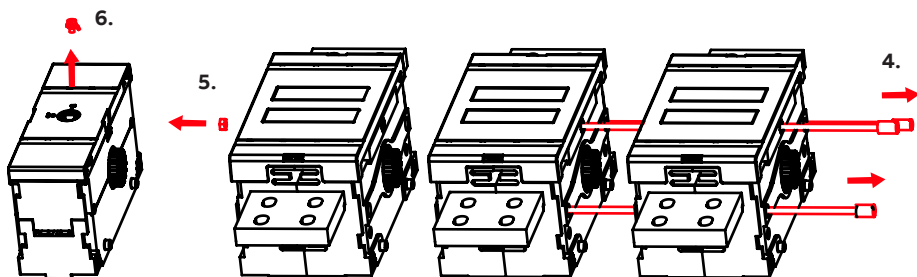

Tools

Flat screwdriver



Disassembled parts

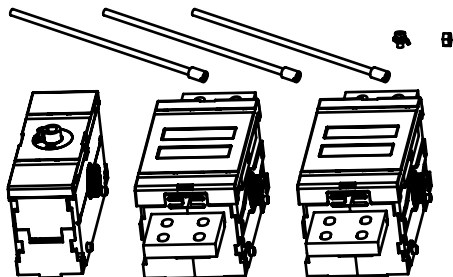

- 3-6 stud screws
- 1 mechanism
- 1-4 poles
- 1 steel hex nut
- 1 lock spring
- 1 slot screw
- 1 steel locking washer
- 1 O-ring

Disassembly of the pole

Phase 1 to 4 – Cover, frame and contact construction

1. Use a flat screwdriver to remove the cover.
2. Use a torx key to unscrew the screws fixing the frames to each other.
3. Remove the contact construction manually.
4. Remove one fixed contact manually.

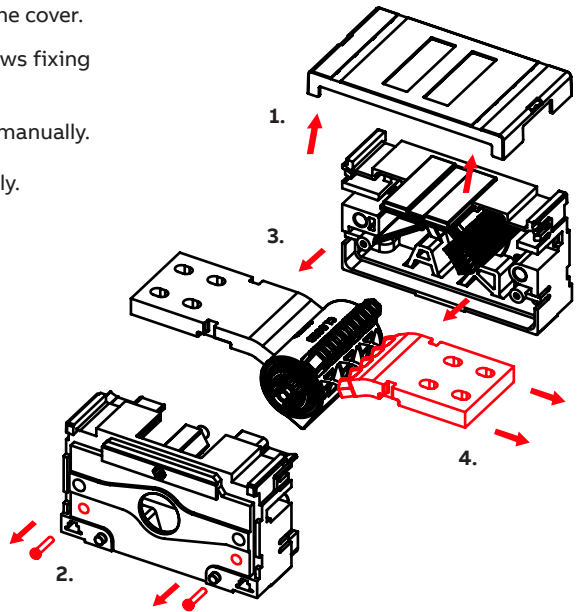

Tools

Torx key (size 25)

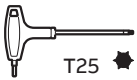

Flat screwdriver



Disassembled parts

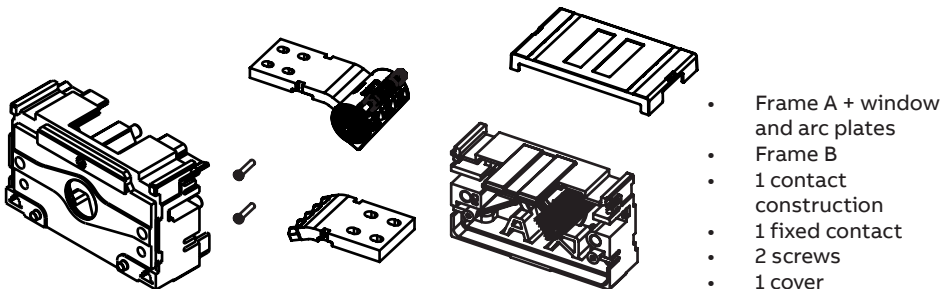

Phase 5 – Arc plates and window

Remove arc plates and window from frame A manually.

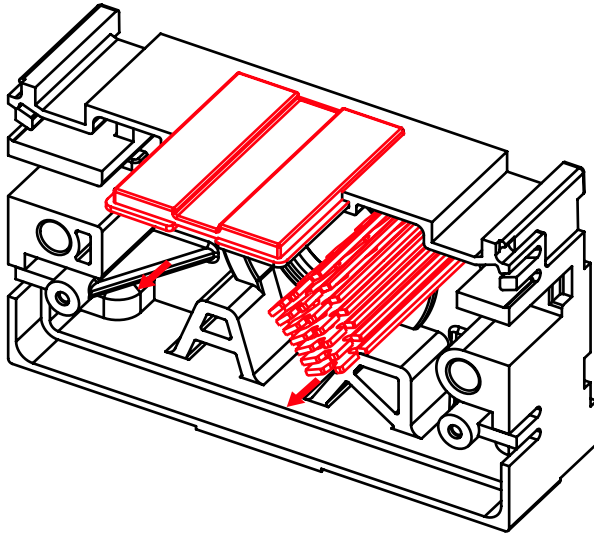

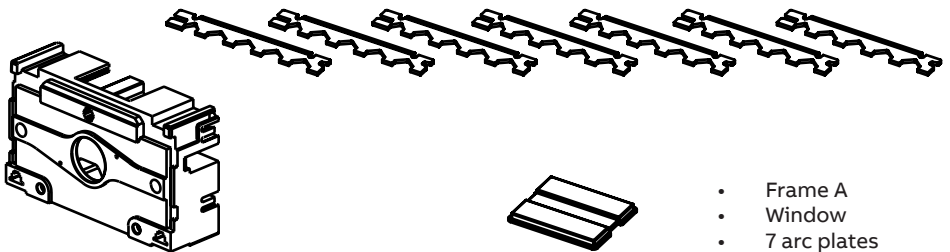
Disassembled parts

- Frame A
- Window
- 7 arc plates

Phase 6 & 7 – The contact construction

6. Remove the second fixed contact and knife structures from the roll manually.

7. Separate contact knives, contact springs and contact irons from each other by removing plugs.

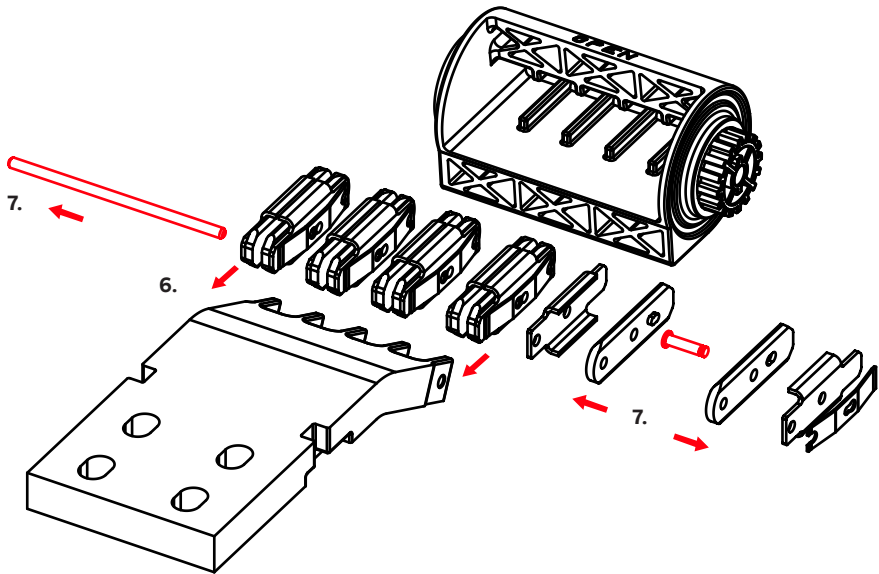

Disassembled parts

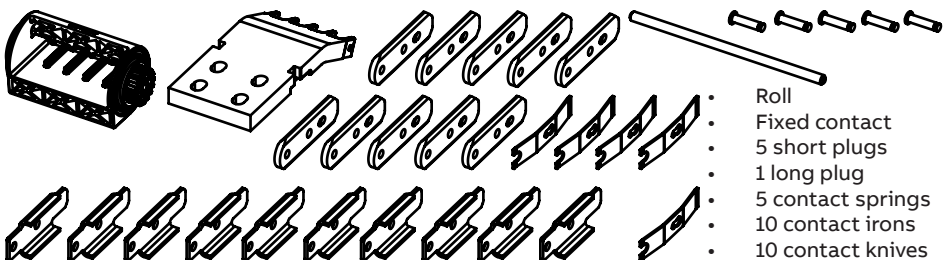

Disassembly of the mechanism

1. Remove the cover with the help of a flat screwdriver.

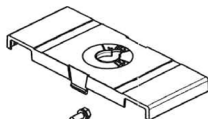

2. Unscrew the 4 screws with a torx key to remove the frame.

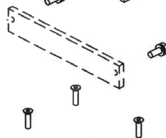

3. Remove hexnuts and contact guide support.

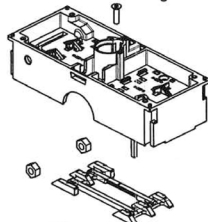

4. Remove the lever.

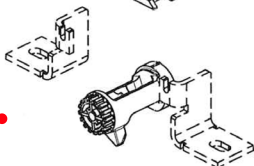

5. Remove pipeshaft, lever and rhythm spring.

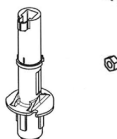

6. Remove the springs using pliers.

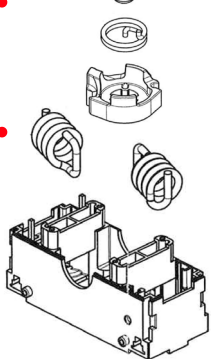

Note! Pay special attention to tensioned springs. Use personal protective equipment.

Tools

Torx key (size 20)

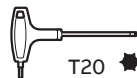

T20

Flat screwdriver



Pliers



Disassembled parts

- Frame
- 2 springs
- 4 steel hex nuts
- Lever
- Pipeshaft
- Lever
- Rhythm spring
- Frame
- 4 screws
- Cover
- Contact guide support

Component list

Change-over switch OT3200_C

Component name	Quantity	Material(s)	Weight (g/pc)
OT3200_C1	1	See component list below	26594,2
OT3200_C2	1	See component list below	26594,6
Joint	1	Steel	147,9
Interm cover	6	Polycarbonate	32,5
Interm cover	2	Polycarbonate	21,8
Mounting plate	2	Steel	15,2
Lockpart	4	Polyamide	0,8
Steel hex screw	4	Steel	14,0
Steel hex screw	4	Steel	11,7
Contact guide support	2	Polyamide	15,6
End plate	2	Polycarbonate	212,4
Screw	12	Steel	2,9
Lock spring	1	Steel	0,2
Slot screw	1	Chromium steel	2,0
Steel locking washer	1	Steel	0,4
O-ring	1	Rubber	0,0
Phase barrier	12	Polycarbonate	127,6
Fillingpart	6	Polycarbonate	25,3
Polyethylene plastic film	1	Polyethylene	5,0
Small plate 67X36	1	Printed paper	0,3

Switch-disconnector OT3200_C1

Component name	Quantity	Material(s)	Weight (g/pc)
Mechanism	1	See component list	2188,0
Pole	3-4	See component list	7993,5
Stud screw	3-6	Steel	52,0-187,0
Steel hex nut	1	Steel	7,0

—
Switch-disconnector OT3200_C2

Component name	Quantity	Material(s)	Weight (g/pc)
Mechanism	1	See component list	2188,4
Pole	3-4	See component list	7993,5
Stud screw	2-4	Steel	52,0-187,0
Steel hex nut	1	Steel	7,0

—
Pole

Component name	Quantity/pole	Material(s)	Weight (g/pc)
Frame A	1	Polyest-resin	1012,7
Frame B	1	Polyest-resin	1171,0
Contact knife	10	Copper	46,8
Contact iron	10	Steel	24,9
Contact spring	5	Chromium steel	5,1
Plug	1	Chromium steel	17,7
Plug	5	Chromium steel	3,5
Roll	1	Polyarylamide	246,2
Arc plate	7	Steel	36,2
Fixed contact	1	Copper	2560,1
Window	1	Polycarbonate	37,3
Cover	1	Polycarbonate	110,1
Screw	2	Steel	8,8

—
Mechanism

Component name	Quantity	Material(s)	Weight (g/pc)
Frame	1	Polyamide	568,2
Frame	1	Polyamide	228,0
Cover	1	Polycarbonate	70,9
Pipeshaft	1	Zinc alloy	234,9
Lever	1	Zinc alloy	315,2
Lever	1	Zinc alloy	365,3
Spring	2	Steel	169,1
Rhythm spring	1	Steel	39,0
Steel hex nut	4	Steel	5,4
Screw	4	Chromium steel	1,7

Recycling information in accordance with the WEEE

The product is marked with the wheelie bin symbol. It indicates that at the end of life the product should enter the recycling system.

You should dispose of it separately at an appropriate collection point and not place it in the normal waste stream.

The figure below shows the wheelie bin symbol indicating separate collection for electrical and electronic equipment (EEE).



The horizontal bar underneath the crossed-out wheelie bin indicates that the equipment has been manufactured after the Directive came into force in 2005.

The wheelie bin symbol is added to the type designation label of the product since 2017.



Contact us

ABB Oy

P.O. Box 622
FI-65101 Vaasa
Finland

abb.com/lowvoltage