

## Data Sheet | Item Number: 891-8994/006-302

pre-assembled interconnecting cable; Eca; Socket/plug; 4-pole; Cod. A; H05VV-F  
4G 1.5 mm<sup>2</sup>; 3 m; 1,50 mm<sup>2</sup>; white

<https://www.wago.com/891-8994/006-302>



Color: ■ white

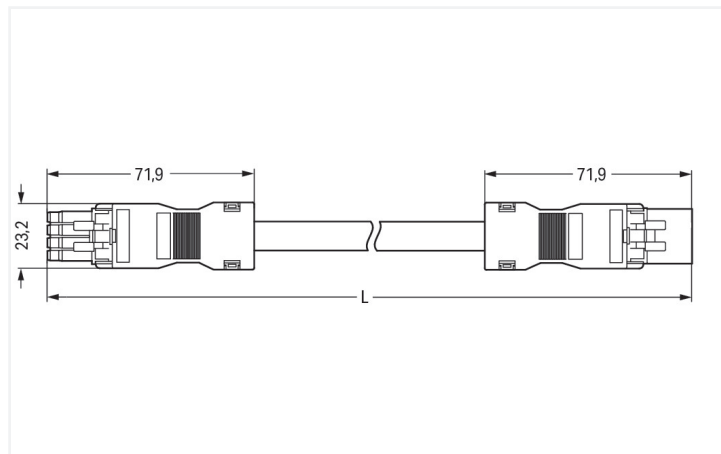

Dimensions in mm

Cable assembly WINSTA® MINI with protection type IP20

The WINSTA® MINI cable assembly A coding allows assembly of fine-stranded and solid conductors. WAGO pluggable installation connectors are used when specifications repeat or are distributed on a specified grid, for example for installing grid lighting or flush-mount lighting. For greater protection in electrical installations, the pluggable installation connector is equipped with mechanical protection against mismatching. General mains applications for almost any domain of use can be implemented with WINSTA® MINI pluggable installation connectors with A coding. Due to its particularly compact dimensions, our WINSTA® MINI Pluggable Connection System with Push-in CAGE CLAMP® spring pressure connection technology is very suitable in very restricted spaces, i.e., for installations when very little room is available. According to the European CPR, the fire class of the cables used for construction is decisive for the safety of buildings as well. For buildings with average safety requirements, cable assemblies with fire class E are suitable.

Pluggable connections instead of screw connections – cable assemblies from WAGO

The cable assembly is provided with a socket and a plug. The WINSTA® Pluggable Connection System is ideally tailored to the very strict requirements of building installation. It makes electrical installation pluggable, and thus more efficient, even more reliable, and error-free. Using this pre-assembled system reduces time spent on assembly and errors during installation at the construction site. Enjoy the benefits of the pluggable version of our maintenance-free spring pressure connection technology too! Plan your installation with with strain relief hosting from WAGO.

- pluggable installation connectors with protection against mismatching
- easy tool-free operation, a wide range of coding options
- with A coding for a great number of uses
- exact dimensions
- quick replacement of defective units during ongoing operation

### Notes

Note Cables with a different fire class can be found in the eShop.

### Electrical data

Ratings per	IEC/EN 60664-1		
Overvoltage category	III	III	II
Pollution degree	3	2	2
Nominal voltage	400 V	-	-
Rated impulse withstand voltage	6 kV	-	-
Rated current	16 A	-	-

### General information

Note on contact resistance approx. 1 mΩ of contact resistance  
approx. 0.25 mΩ contact transition plug/  
socket

## Connection Data

Total number of potentials	4	<b>Connection 1</b>	
PE function	Preceding PE contact	Pole number	4
		Wire cross-section	1.5 mm <sup>2</sup>
		Connection type	Socket - Plug

## Physical data

Pin spacing	4.4 mm / 0.173 inches
Width	23.2 mm / 0.913 inches
Height	16 mm / 0.63 inches
Total length	3 m

## Mechanical data

Use	General mains applications
Coding	A
Variable coding	No
Marking	N ⊕ 2/L 1/L'
Potential marking	N ⊕ 2/L 1/L'
Mating force of a plug-in connection	approx. 20 ... 70 N (depending on pole number)
Retention force of a plug-in connection	when locked: > 80N
Unmating force of a plug-in connection	when unlocked: approx. 20 ... 70 N (depending on pole number)
Number of mating cycles	200, without resistive load
Connection type	Socket - Plug
Type of pre-assembled cable	Interconnecting cable
Cable type	H05VV-F 4G1.5
Protection type	IP20; IP40 when mated

## Plug-in connection

Mismating protection	Yes
Note on mismating protection	All WINSTA® components are 100% protected against mismating when: a.) plugging different numbers of poles b.) plugging while rotated 180 c.) plugging while laterally staggered d.) plugging one pole
Locking lever	Can be retrofitted
Locking of plug-in connection	Locking lever
Note on locking system	All connectors for mounted installations (snap-in versions for lighting fixtures or devices, all types of PCB and distribution connectors) are factory-equipped with locking levers to ensure plugs and sockets are securely locked. Additional locking levers are only required for flying leads (plug/socket).

## Material data

Note (material data)	<a href="#">Information on material specifications can be found here</a>
Color	white
Insulation material (main housing)	Polyamide (PA66)
Fire class per EN 50575	E <sub>ca</sub>
Contact material	Copper or copper alloy; surface-treated
Contact Plating	Tin
Fire load	89.886 MJ
Connector color	white
Strain relief color	white
Sheathed cable color	white
Printing color of sheathed cable	black
Halogen-free	No

### Material data

Silicon-free	Yes
Sheath material	PVC
Rubber cable	No
Weight	409.7 g
Copper weight of the raw cable	0.058 kg/m

### Environmental requirements

Processing temperature	-5 ... +40 °C
Continuous operating temperature	-35 ... +85 °C
Note on continuous operating temperature	Cable for temperatures ≤ 70 °C (including halogen-free) Insulating parts for temperatures ≤ 105 °C

### Commercial data

PU (SPU)	1 pcs
Packaging type	unpacked
Country of origin	PL
GTIN	4055143404181
Customs tariff number	85444290900

### Product Classification

UNSPSC	26121629
eCl@ss 10.0	27-44-06-04
eCl@ss 9.0	27-44-06-04
ETIM 9.0	EC002587
ETIM 10.0	EC002587
ECCN	NO US CLASSIFICATION

### Environmental Product Compliance

RoHS Compliance Status	Compliant, No Exemption
------------------------	-------------------------

### Approvals / Certificates

#### General approvals



Approval	Standard	Certificate Name
CCA DEKRA Certification B.V.	EN 61535	NTR NL-7971
KEMA/KEUR DEKRA Certification B.V.	EN 61535	71-123232

## Downloads

### Environmental Product Compliance

#### Compliance Search

Environmental Product Compliance  
891-8994/006-302



## Documentation

### Bid Text

891-8994/006-302	19.02.2019	xml 2.90 KB	
891-8994/006-302	01.12.2014	doc 24.50 KB	

## CAD/CAE-Data

### CAE data

EPLAN Data Portal  
891-8994/006-302



WSCAD Universe  
891-8994/006-302



## 1 Compatible Products

### 1.1 Required Accessories

#### 1.1.1 Locking system

##### 1.1.1.1 Locking system



[Item No.: 890-111](#)

Locking lever; for flying leads; for tool operation; black

[Item No.: 890-131](#)

Locking lever; for flying leads; for tool operation; white

[Item No.: 890-101](#)

Locking lever; for manual operation; black

[Item No.: 890-121](#)

Locking lever; for manual operation; white

### 1.2 Optional Accessories

#### 1.2.1 Cover

##### 1.2.1.1 Cover



[Item No.: 897-2003](#)

Protective cap; Type2; for sockets and plugs; PVC; red

## 1.2.2 Installation

### 1.2.2.1 Mounting accessories



**Item No.: 890-310**

Mounting carrier; 2- to 5-pole; for flying leads; black

**Item No.: 890-311**

Mounting carrier; 2- to 5-pole; for flying leads; white