

Data Sheet | Item Number: 891-8994/106-501

pre-assembled connecting cable; Eca; Socket/open-ended; 4-pole; Cod. A; H05VV-F 4G 1.5 mm²; 5 m; 1,50 mm²; black

<https://www.wago.com/891-8994/106-501>

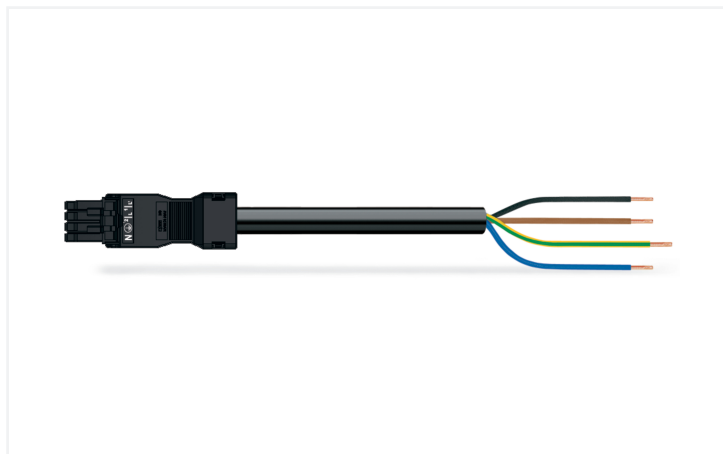

Color: ■ black

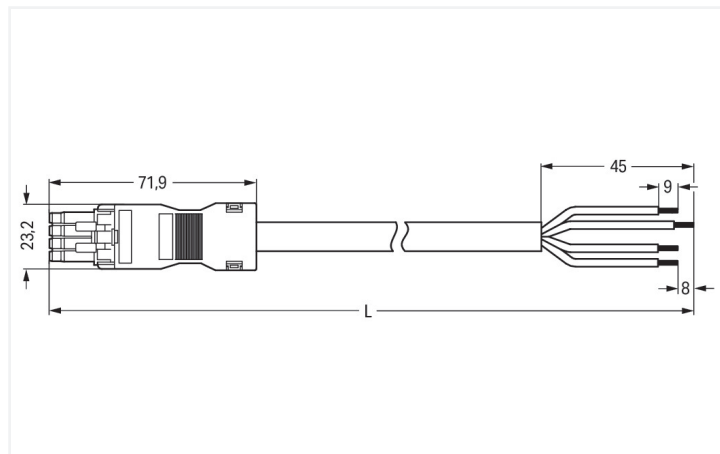

Dimensions in mm

Cable assembly WINSTA® MINI A coding

Use effective pluggable connections instead of laborious screw connections: With the WINSTA® MINI cable assembly rated current 16 A. Whether on PCBs, in control cabinets or for connecting lights – pluggable installation connectors from WAGO allow you to establish connections according to many different requirements in seconds. The color coding and mechanical coding of the pluggable installation connector ensure error-free installation of the individual components – including protection against mismatching. The pluggable installation connector offers protection against contact with wires or tools if they are smaller than 1 mm in accordance with protection type IP40. Thanks to the color coding and mechanical A coding of WINSTA® MINI pluggable installation connectors, you can clearly distinguish different circuits. WINSTA® MINI follows the trend towards miniaturisation. Our smallest pluggable connection system is primarily suited for lights, for instance, since due to LED technology, these offer less and less space for the connection technology. This product meets all the relevant safety requirements of fire class E; therefore it can be used in domains where fire safety is relevant.

Pluggable connections instead of screw connections – cable assemblies from WAGO

A socket and a free end are available. The WINSTA® Pluggable Connection System allows pluggable electrical installation. This significantly reduces the need for servicing and lowers costs. Now you can also reduce installation expenses without compromising quality and safety: with marking reduces the need for servicing and prevents unnecessary downtime.

- effective protection against mismatching
- consistent IP40 protection
- with A coding for use in many general mains applications
- flexible installation to save space
- quick replacement of defective units during ongoing operation

Notes

Note Cables with a different fire class can be found in the eShop.

Electrical data

Rated per	IEC/EN 60664-1		
Overvoltage category	III	III	II
Pollution degree	3	2	2
Nominal voltage	400 V	-	-
Rated impulse withstand voltage	6 kV	-	-
Rated current	16 A	-	-

General information

Note on contact resistance approx. 1 mΩ of contact resistance
approx. 0.25 mΩ contact transition plug/
socket

Connection Data

Total number of potentials	4	Connection 1	
PE function	Preceding PE contact	Strip length	9 mm / 0.35 inches
Conductor preparation	ultrasonically tip-bonded	Pole number	4
		Wire cross-section	1.5 mm ²
		Strip length (outer insulation)	45 mm
		Connection type	Socket - free end

Physical data

Pin spacing	4.4 mm / 0.173 inches
Width	23.2 mm / 0.913 inches
Height	16 mm / 0.63 inches
Total length	5 m

Mechanical data

Use	General mains applications
Coding	A
Variable coding	No
Marking	N ⊕ 2/L 1/L'
Potential marking	N ⊕ 2/L 1/L'
Mating force of a plug-in connection	approx. 20 ... 70 N (depending on pole number)
Retention force of a plug-in connection	when locked: > 80N
Unmating force of a plug-in connection	when unlocked: approx. 20 ... 70 N (depending on pole number)
Number of mating cycles	200, without resistive load
Connection type	Socket - free end
Type of pre-assembled cable	Connecting cable
Cable type	H05VV-F 4G1.5
Protection type	IP40

Plug-in connection

Mismating protection	Yes
Note on mismating protection	All <i>WINSTA</i> ® components are 100% protected against mismating when: a.) plugging different numbers of poles b.) plugging while rotated 180 c.) plugging while laterally staggered d.) plugging one pole
Locking lever	Can be retrofitted
Locking of plug-in connection	Locking lever
Note on locking system	All connectors for mounted installations (snap-in versions for lighting fixtures or devices, all types of PCB and distribution connectors) are factory-equipped with locking levers to ensure plugs and sockets are securely locked. Additional locking levers are only required for flying leads (plug/socket).

Material data

Note (material data)	Information on material specifications can be found here
Color	black
Insulation material (main housing)	Polyamide (PA66)
Fire class per EN 50575	E _{ca}
Contact material	Copper or copper alloy; surface-treated
Contact Plating	Tin
Fire load	149.915 MJ
Connector color	black
Strain relief color	black
Sheathed cable color	black

Material data

Printing color of sheathed cable	white
Halogen-free	No
Silicon-free	Yes
Sheath material	PVC
Rubber cable	No
Weight	659.4 g
Copper weight of the raw cable	0.058 kg/m

Environmental requirements

Processing temperature	-5 ... +40 °C
Continuous operating temperature	-35 ... +85 °C
Note on continuous operating temperature	Cable for temperatures ≤ 70 °C (including halogen-free) Insulating parts for temperatures ≤ 105 °C

Commercial data

PU (SPU)	1 pcs
Packaging type	unpacked
Country of origin	PL
GTIN	4055143403986
Customs tariff number	85444290900

Product Classification

UNSPSC	26121629
eCl@ss 10.0	27-44-06-04
eCl@ss 9.0	27-44-06-04
ETIM 9.0	EC002587
ETIM 10.0	EC002587
ECCN	NO US CLASSIFICATION

Environmental Product Compliance

RoHS Compliance Status	Compliant, No Exemption
------------------------	-------------------------

Approvals / Certificates

General approvals



Approval	Standard	Certificate Name
CCA DEKRA Certification B.V.	EN 61535	NTR NL-7971
KEMA/KEUR DEKRA Certification B.V.	EN 61535	71-123232

Downloads

Environmental Product Compliance

Compliance Search

Environmental Product Compliance
891-8994/106-501



Documentation

Bid Text

891-8994/106-501	19.02.2019	xml 2.98 KB	
891-8994/106-501	01.12.2014	doc 24.50 KB	

CAD/CAE-Data

CAE data

EPLAN Data Portal
891-8994/106-501



WSCAD Universe
891-8994/106-501



1 Compatible Products

1.1 Required Accessories

1.1.1 Locking system

1.1.1.1 Locking system



[Item No.: 890-111](#)

Locking lever; for flying leads; for tool operation; black

[Item No.: 890-131](#)

Locking lever; for flying leads; for tool operation; white

[Item No.: 890-101](#)

Locking lever; for manual operation; black

[Item No.: 890-121](#)

Locking lever; for manual operation; white

1.2 Optional Accessories

1.2.1 Cover

1.2.1.1 Cover



[Item No.: 897-2003](#)

Protective cap; Type2; for sockets and plugs; PVC; red

1.2.2 Installation

1.2.2.1 Mounting accessories



Item No.: [890-310](#)

Mounting carrier; 2- to 5-pole; for flying leads; black



Item No.: [890-311](#)

Mounting carrier; 2- to 5-pole; for flying leads; white