

Data Sheet | Item Number: 891-8985/206-402

pre-assembled connecting cable; Eca; Plug/open-ended; 5-pole; Cod. I; H05VV-F
5G 1.5 mm²; 4 m; 1,50 mm²; blue

<https://www.wago.com/891-8985/206-402>

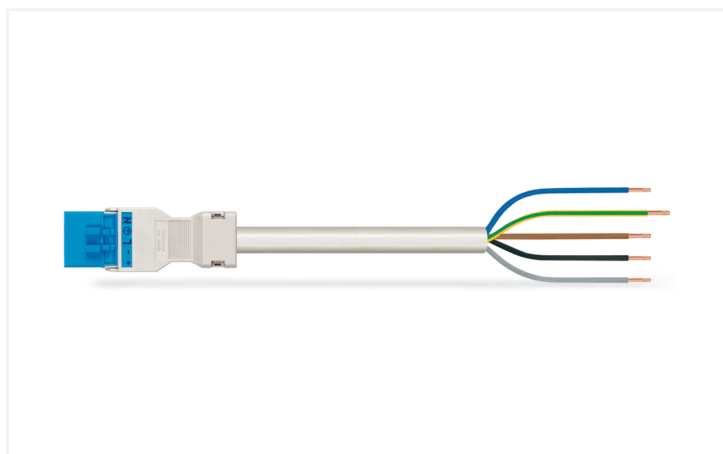

Color: ■ blue

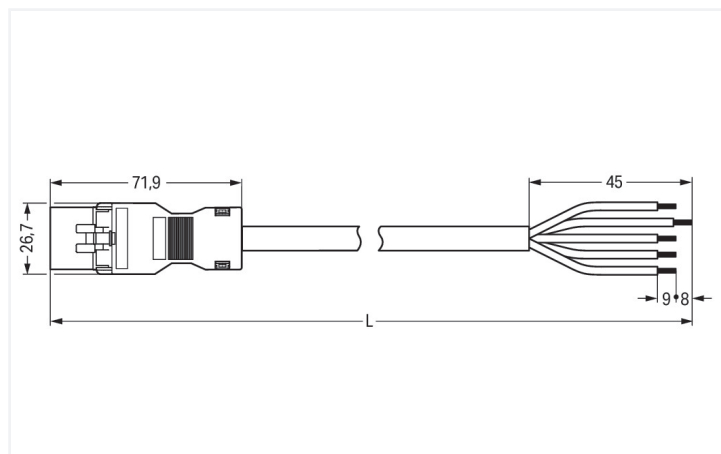

Dimensions in mm

Cable assembly WINSTA® MINI with protection type IP20

The WINSTA® MINI cable assembly rated current 16 A is the pluggable solution for your application in control cabinets, on PCBs or for lighting connections. Whether on PCBs, in control cabinets or for connecting lights – pluggable installation connectors from WAGO allow you to make connections according to an enormous variety of requirements in seconds. For greater security in electrical installations, the pluggable installation connector is equipped with mechanical protection against mismatching. Controlled lighting, as implemented in the DALI standard, for example, is the main use of WINSTA® MINI pluggable installation connectors with I coding. Where space is tight, our smallest pluggable connection system, WINSTA® MINI, conveniently displays its strengths. It saves space, and, thanks to Push-in CAGE CLAMP® spring pressure connection technology, it additionally can be installed quickly, since the connection is low-maintenance and requires no screw connections. According to the European CPR, the fire class of the cables used for construction is critical for the safety of buildings, too. For buildings with average safety requirements, cable assemblies with fire class E are suitable.

Fast, error-free assembly thanks to cable assemblies from WAGO

The cable is pre-assembled with a plug and a free end. The WINSTA® Pluggable Connection System allows pluggable electrical installation. This significantly reduces the need for servicing and lowers costs. Now you can also reduce installation expenses without compromising quality and safety: with fire class E reduces the need for servicing and prevents unnecessary downtime.

- pluggable installation connectors with protection against mismatching
- compact design for conductors with a cross-section up to 1.5 mm²
- with I coding for use in the automation of buildings (lighting control)
- ready for immediate use
- rapid, structured electrical installation

Notes

Note Cables with a different fire class can be found in the eShop.

Electrical data

Ratings per	IEC/EN 60664-1		
Overvoltage category	III	III	II
Pollution degree	3	2	2
Nominal voltage	400 V	-	-
Rated impulse withstand voltage	6 kV	-	-
Rated current	16 A	-	-

General information

Note on contact resistance approx. 1 mΩ of contact resistance
approx. 0.25 mΩ contact transition plug/
socket

Connection Data

Total number of potentials	5
PE function	Preceding PE contact
Conductor preparation	ultrasonically tip-bonded

Connection 1

Strip length	9 mm / 0.35 inches
Pole number	5
Wire cross-section	1.5 mm ²
Strip length (outer insulation)	45 mm
Connection type	Plug - free end

Physical data

Pin spacing	4.4 mm / 0.173 inches
Width	26.7 mm / 1.051 inches
Height	15.8 mm / 0.622 inches
Total length	4 m

Mechanical data

Use	DALI, Lighting Management
Coding	I
Variable coding	No
Marking	N ⊕ L - +
Potential marking	N ⊕ L - +
Mating force of a plug-in connection	approx. 20 ... 70 N (depending on pole number)
Retention force of a plug-in connection	when locked: > 80N
Unmating force of a plug-in connection	when unlocked: approx. 20 ... 70 N (depending on pole number)
Number of mating cycles	200, without resistive load
Connection type	Plug - free end
Type of pre-assembled cable	Connecting cable
Cable type	H05VV-F 5G1.5
Protection type	IP20; IP40 when mated

Plug-in connection

Mismating protection	Yes
Note on mismating protection	All <i>WINSTA</i> ® components are 100% protected against mismating when: a.) plugging different numbers of poles b.) plugging while rotated 180 c.) plugging while laterally staggered d.) plugging one pole
Locking lever	Can be retrofitted
Locking of plug-in connection	Locking lever
Note on locking system	All connectors for mounted installations (snap-in versions for lighting fixtures or devices, all types of PCB and distribution connectors) are factory-equipped with locking levers to ensure plugs and sockets are securely locked. Additional locking levers are only required for flying leads (plug/socket).

Material data

Note (material data)	Information on material specifications can be found here
Color	blue
Insulation material (main housing)	Polyamide (PA66)
Fire class per EN 50575	E _{ca}
Contact material	Copper or copper alloy; surface-treated
Contact Plating	Tin
Fire load	119.974 MJ
Connector color	blue
Strain relief color	white
Sheathed cable color	white

Material data

Printing color of sheathed cable	black
Halogen-free	No
Silicon-free	Yes
Sheath material	PVC
Rubber cable	No
Weight	630.2 g
Copper weight of the raw cable	0.072 kg/m

Environmental requirements

Processing temperature	-5 ... +40 °C
Continuous operating temperature	-35 ... +85 °C
Note on continuous operating temperature	Cable for temperatures ≤ 70 °C (including halogen-free) Insulating parts for temperatures ≤ 105 °C

Commercial data

PU (SPU)	1 pcs
Packaging type	unpacked
Country of origin	PL
GTIN	4055143398602
Customs tariff number	85444290900

Product Classification

UNSPSC	26121629
eCl@ss 10.0	27-44-06-04
eCl@ss 9.0	27-44-06-04
ETIM 9.0	EC002587
ETIM 10.0	EC002587
ECCN	NO US CLASSIFICATION

Environmental Product Compliance

RoHS Compliance Status	Compliant, No Exemption
------------------------	-------------------------

Approvals / Certificates

General approvals



Approval	Standard	Certificate Name
CCA DEKRA Certification B.V.	EN 61535	NTR NL-7971
KEMA/KEUR DEKRA Certification B.V.	EN 61535	71-123232

Downloads

Environmental Product Compliance

Compliance Search

Environmental Product Compliance
891-8985/206-402



Documentation

Bid Text

891-8985/206-402	19.02.2019	xml 3.02 KB	
891-8985/206-402	02.12.2014	doc 25.50 KB	

CAD/CAE-Data

CAE data

WSCAD Universe
891-8985/206-402



1 Compatible Products

1.1 Required Accessories

1.1.1 Locking system

1.1.1.1 Locking system



Item No.: 890-111

Locking lever; for flying leads; for tool operation; black

Item No.: 890-131

Locking lever; for flying leads; for tool operation; white

Item No.: 890-101

Locking lever; for manual operation; black

Item No.: 890-121

Locking lever; for manual operation; white

1.2 Optional Accessories

1.2.1 Cover

1.2.1.1 Cover



Item No.: 897-2003

Protective cap; Type2; for sockets and plugs; PVC; red

1.2.2 Installation

1.2.2.1 Mounting accessories



Item No.: [890-310](#)

Mounting carrier; 2- to 5-pole; for flying leads; black



Item No.: [890-311](#)

Mounting carrier; 2- to 5-pole; for flying leads; white