

PROLUMIA®

PRO-SPACE



OPERATING INSTRUCTION

GEBRUIKSAANWIJZING
MANUEL D'UTILISATION
INSTALAČNÍ NÁVOD
GEBRAUCHSANLEITUNG

4000420x	Pro-Space R Ø75mm, 6W
4000421x	Pro-Space R Ø100mm, 8W
4000422x	Pro-Space R Ø125mm, 11W
4000423x	Pro-Space R Ø155mm, 15W
4000424x	Pro-Space R Ø185mm, 22W
4000425x	Pro-Space R Ø215mm, 30W

4000426x	Pro-Space S 75x75mm, 6W
4000427x	Pro-Space S 100x100mm, 8W
4000428x	Pro-Space S 125x125mm, 11W
4000429x	Pro-Space S 155x155mm, 15W
4000430x	Pro-Space S 185x185mm, 22W
4000431x	Pro-Space S 215x215mm, 30W

CE □ IP66  

ROND

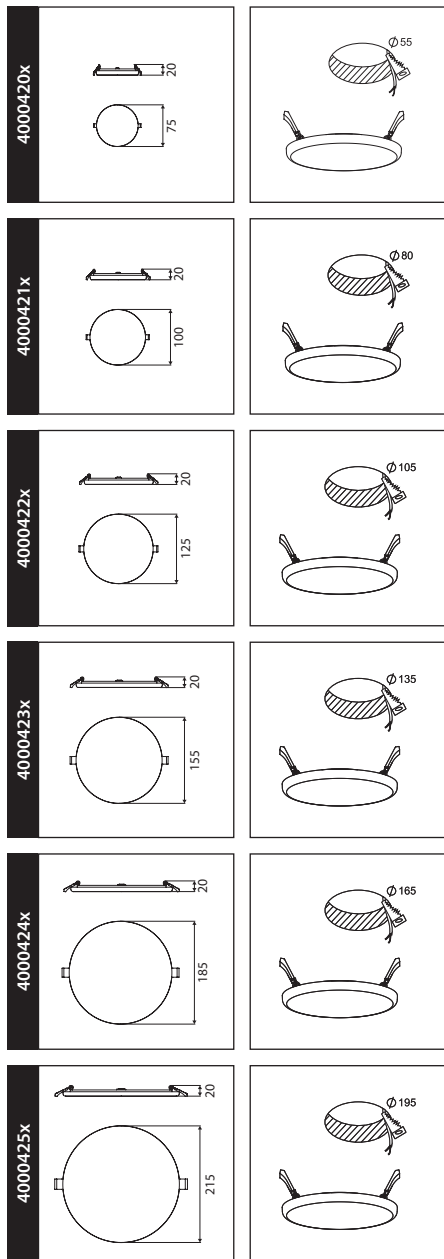

VIERTANT

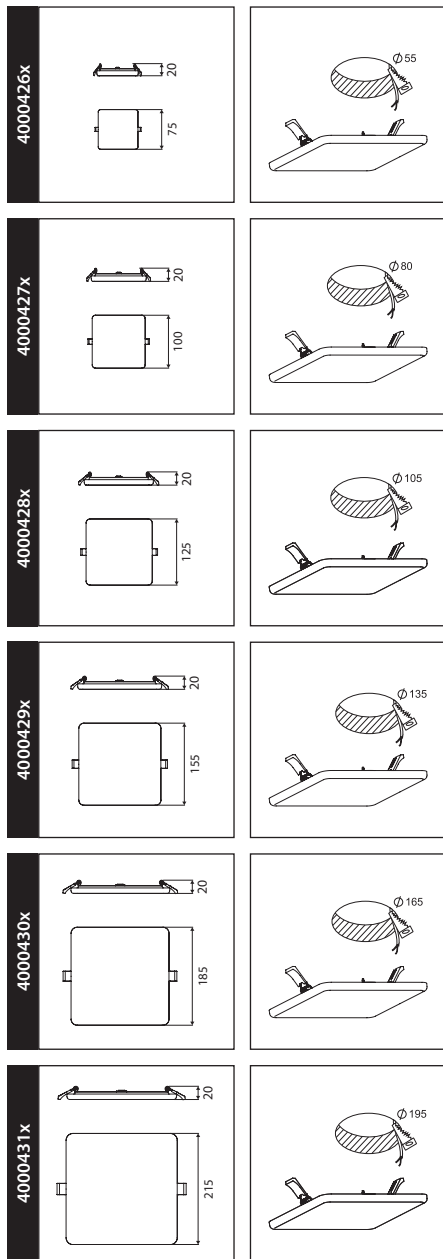

ATTENTIE

Lees de volgende instructies zorgvuldig door om ervoor te zorgen dat de montagewerkzaamheden op de juiste manier worden uitgevoerd. Bewaar deze instructies goed voor eventueel toekomstig gebruik.

OPGELET

1. Installatie en onderhoud van het armatuur moeten worden gedaan door gekwalificeerd personeel.
2. Het armatuur is IP66 en is bedoeld voor gebruik in vochtige ruimtes, met uitzondering van de driver (IP40).
3. Sluit geen niet-dimbare driver op een dimmer aan, om schade aan de driver te voorkomen.
4. Let op de labels of de driver dimbaar of niet-dimbaar is.
5. Als de externe bedrading is beschadigd, moet deze door gekwalificeerd personeel worden vervangen om schade te voorkomen.
6. Dit armatuur is niet geschikt om afgedekt te worden door isolerend materiaal.
7. Dit product bevat een lichtbron van energie-efficiëntieklasse E.

MONTAGE

1

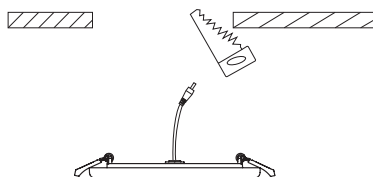

Maak een sparing met de juiste afmeting. Zie pagina 2 voor de maatvoering.

2

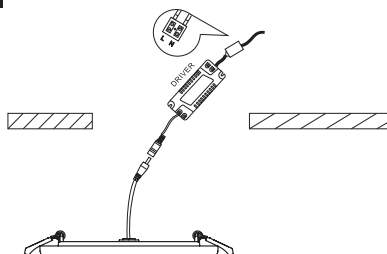

Sluit de voeding aan op de driver. Verbind de driver en het armatuur met behulp van de snoeren met connector.

3

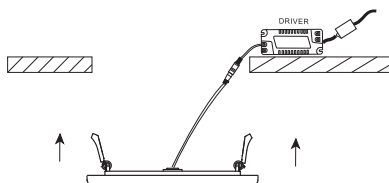

4



NL

EN

FR

CZ

DE

ROUND

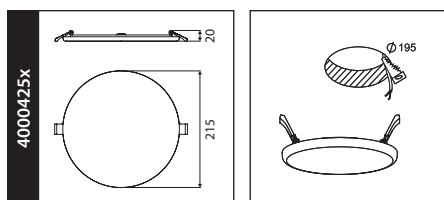
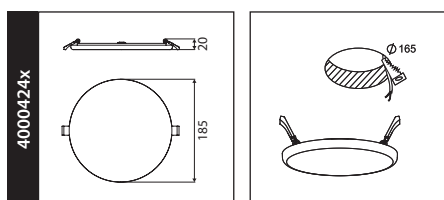
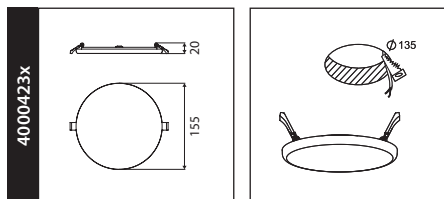
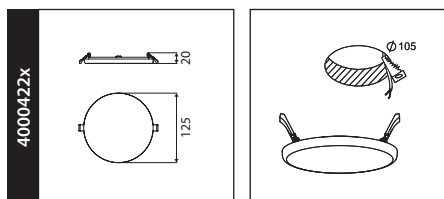
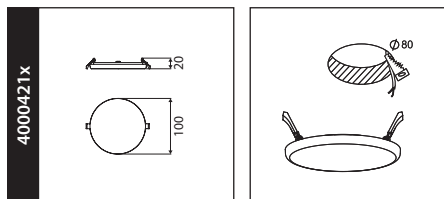
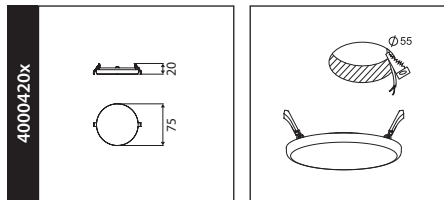

SQUARE

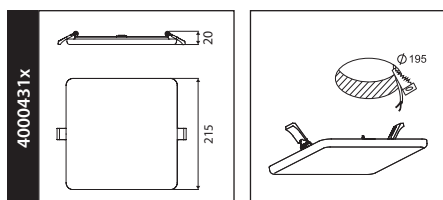
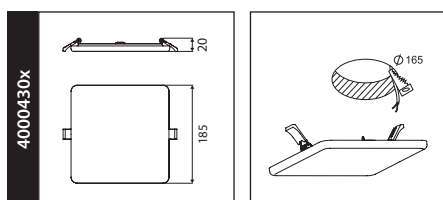
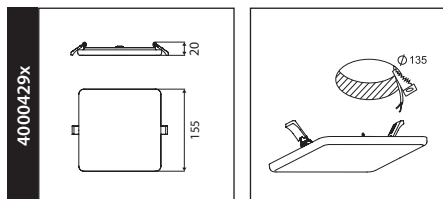
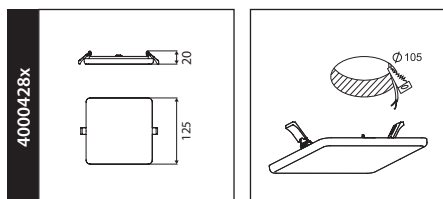
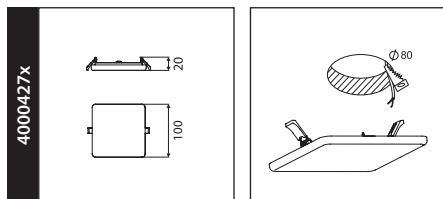
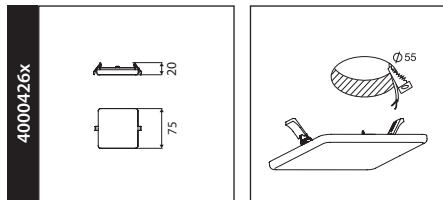

ATTENTION

Please read the following instructions carefully to ensure that mounting operation will be carried out correctly. These instructions should be properly preserved for future reference.

CAUTION

1. The installation and the maintenance of this luminaire must be done by a qualified person.
2. The luminaire is IP66 and is intended for use in humid areas, except driver (IP40).
3. To prevent damages to the luminaire, do not connect a non-dimmable driver with a dimmer.
4. Dimmable or non dimmable, please pay attention to the labels.
5. If the external flexible cable or cord of this luminaire is damaged, it has to be replaced by a qualified person, like the manufacturer or his service agent.
6. The luminaire is not suitable for covering with thermal insulating material.
7. This product contains a light source of energy efficiency class E.

MOUNTING

1

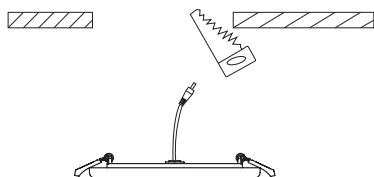

Cut a hole. For the right cut out size refer to the corresponding item number on page 4.

2

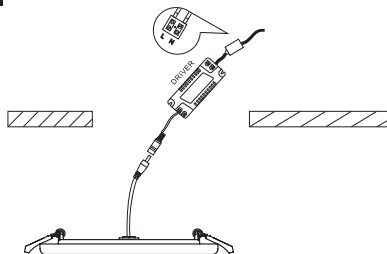

Connect the power wire to the driver. Connect the plug of the driver with the plug of the luminaire.

3

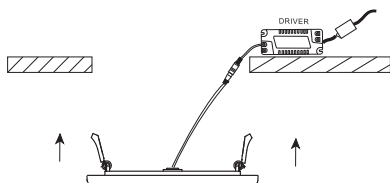

4



NL

EN

FR

CZ

DE

ROND

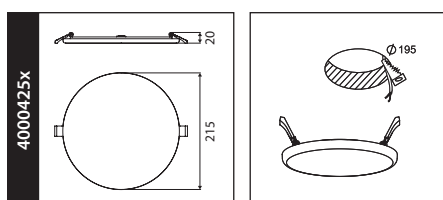
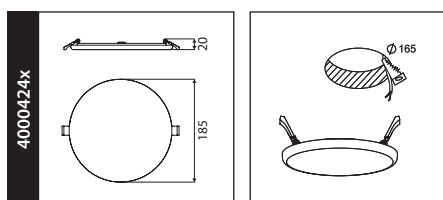
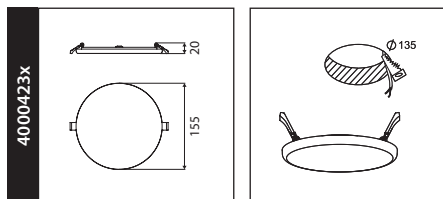
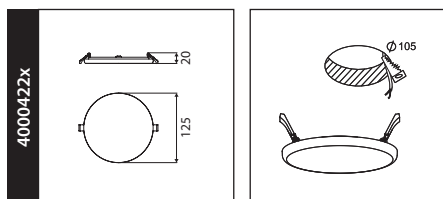
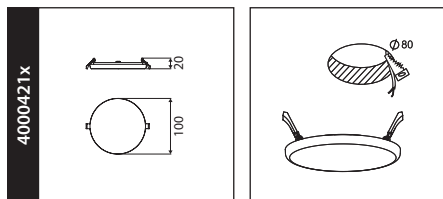
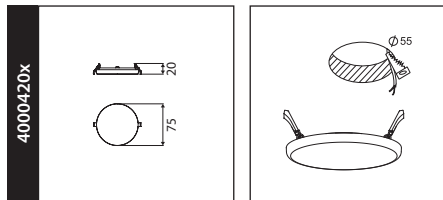

CARRÉ

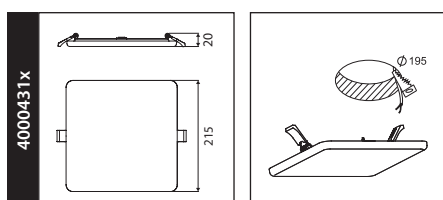
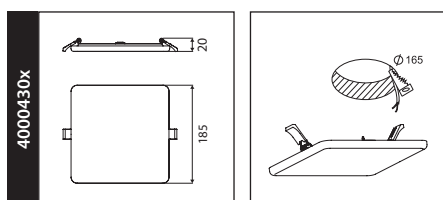
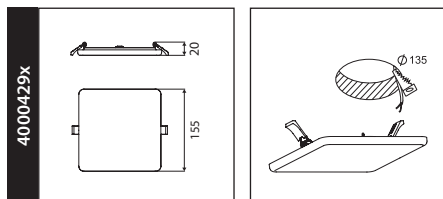
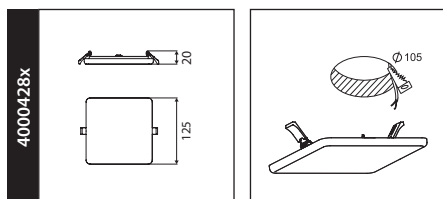
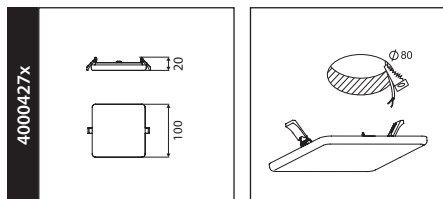
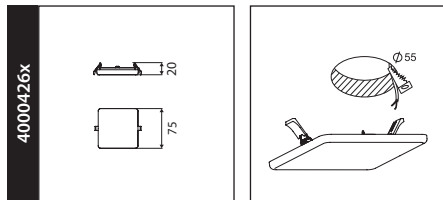

ATTENTION

Lisez attentivement les instructions suivantes pour vous assurer que les travaux d'installation sont effectués correctement. Conservez ces instructions en toute sécurité pour une utilisation future possible.

ATTENTION

1. L'installation et l'entretien du luminaire doivent être effectués par du personnel qualifié.
2. Le luminaire est IP66 et est destiné à être utilisé dans des locaux humides, à l'exception du pilote (IP40).
3. Ne connectez pas un pilote non dimmable à un gradateur pour éviter de l'endommager.
4. Notez les étiquettes si le pilote est dimmable ou non-dimmable
5. Si le câblage externe est endommagé, il doit être remplacé par du personnel qualifié pour éviter tout endommagement.
6. Ce luminaire ne convient pas pour être recouvert d'un matériau isolant.
7. Ce produit contient une source lumineuse de classe d'efficacité énergétique E.

INSTALLATION

1

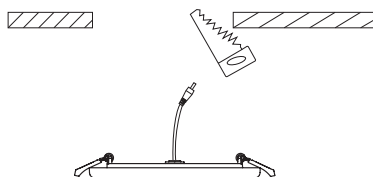

Faites une pause avec la bonne taille.
Voir page 6 pour les dimensions.

2

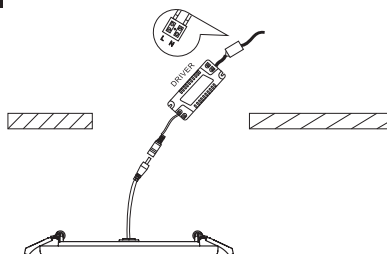

Connectez l'alimentation au pilote. Connectez le pilote et l'appareil à l'aide des cordons avec connecteur.

3

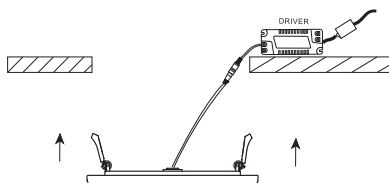

4

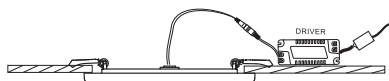

NL

EN

FR

CZ

DE

KRUH

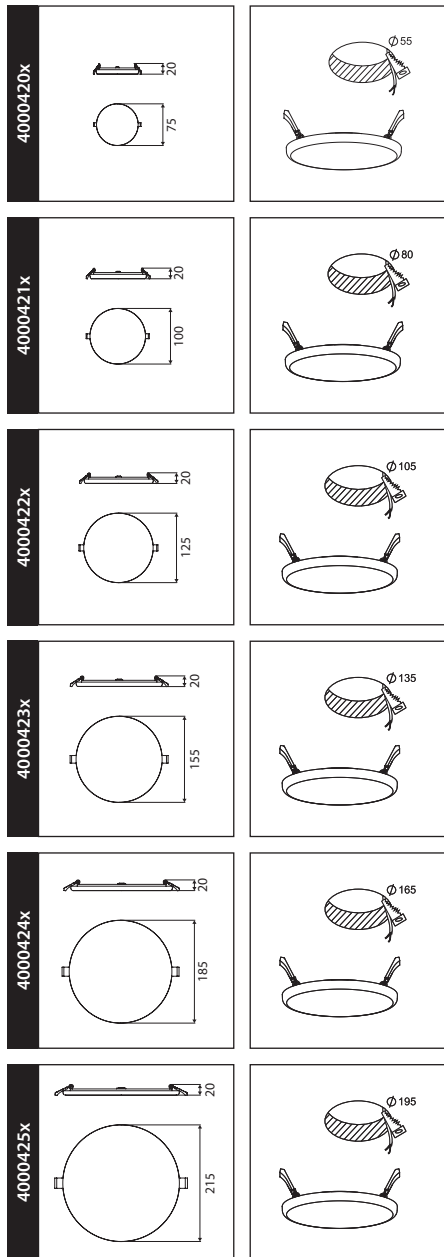

ČTVEREC

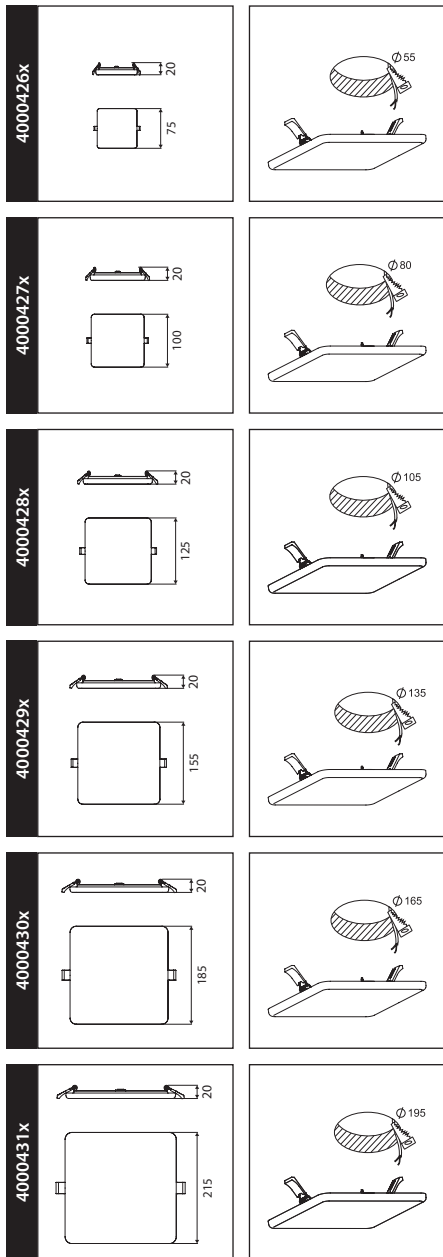

UPOZORNĚNÍ

Prosíme, přečtěte si pozorně návod k použití před začátkem instalace. Tento návod k použití si uchovejte pro případnou budoucí potřebu.

UPOZORNĚNÍ

1. Instalace a údržba svítidla musí být provedena kvalifikovaným pracovníkem.
2. Svítidlo je v krytí IP66 a je určeno pro použití na vlhkých místech, kromě driveru (IP40).
3. Aby nedošlo k poškození svítidla, nepřipojujte driver, který není stmívatelný, ke stmívači.
4. Typ svítidla: stmívatelné nebo standardní je uveden na výrobním štítku svítidla.
5. V případě poškození vnějšího přívodního kabelu, musí být kabel nahrazen výhradně výrobcem nebo jeho smluvním servisním technikem.
6. Svítidla nejsou vhodná pro pokrytí tepelně izolačním materiálem.
7. Tento výrobek obsahuje světelný zdroj s třídou energetické účinnosti E.

MONTÁŽ

1

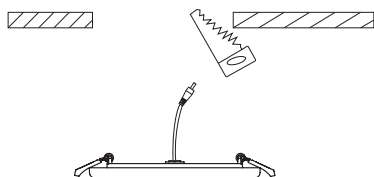

Vyřízněte otvor. Velikost otvoru je znázorněna na straně 8 dle příslušného obj.č.

2

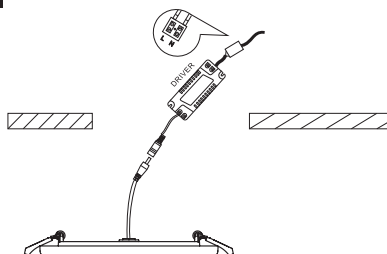

Připojte přívodní kabel k driveru. Připojte driver ke svítidlu.

3

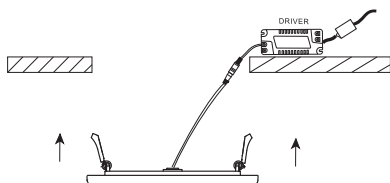

4



NL

EN

FR

CZ

DE

RUND

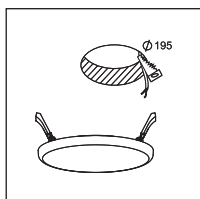
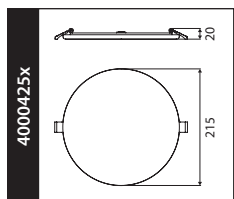
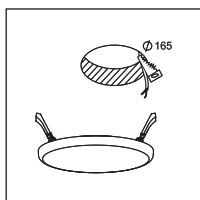
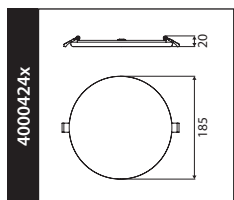
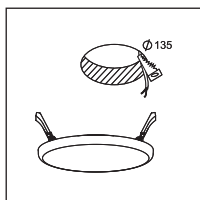
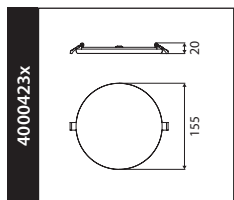
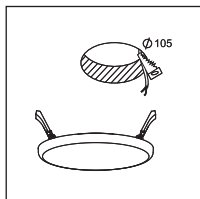
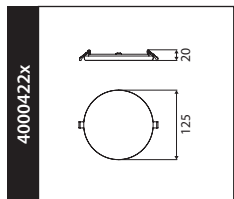
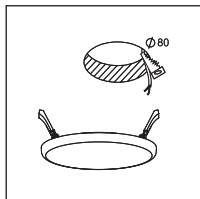
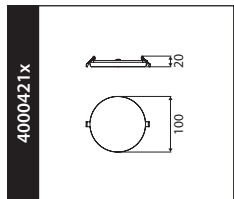
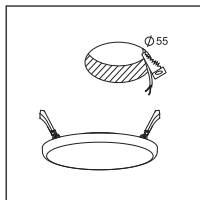
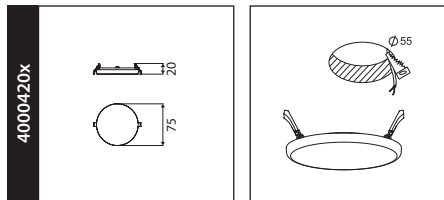

QUADRATISCH

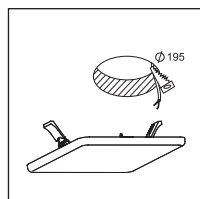
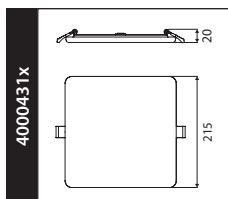
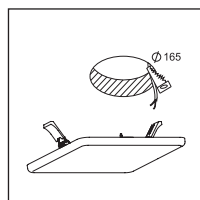
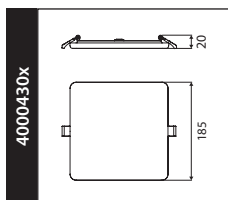
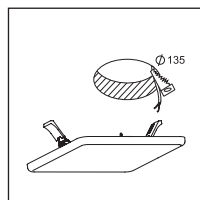
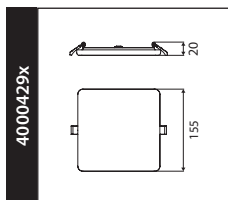
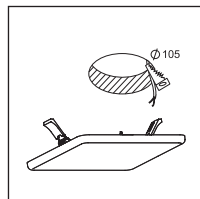
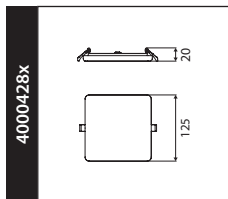
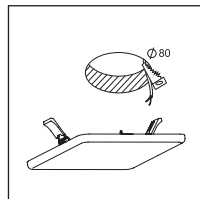
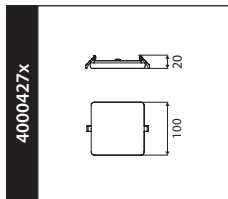
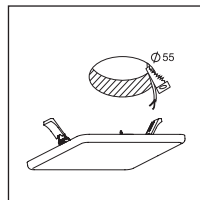
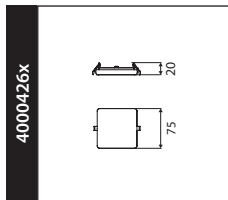

ACHTUNG

Lesen Sie die folgende Anleitung bitte aufmerksam durch, um eine korrekte Ausführung der Montage zu gewährleisten. Bewahren Sie diese Anleitung zum späteren Nachschlagen gut auf.

HINWEIS

1. Die Installation und Wartungen der Leuchte dürfen nur von einer qualifizierten Person durchgeführt werden.
2. Die Leuchte ist IP66 und ist für den Einsatz in Feuchträumen vorgesehen, mit Ausnahme des Treibers (IP40).
3. Um Schäden an der Leuchte zu vermeiden, darf kein nicht dimmbarer Treiber mit einem Dimmer verbunden werden.
4. Dimmbar oder nicht dimmbar, bitte die Beschriftung des Treibers beachten.
5. Ist das externe flexible Kabel oder die Leitung dieser Leuchte beschädigt, muss es von einer qualifizierten Person, wie dem Hersteller oder seinem Servicepartner, ausgetauscht werden.
6. Die Leuchte darf nicht mit Dämmmaterial abgedeckt werden.
7. Dieses Produkt enthält eine Lichtquelle der Energieeffizienzklasse E.

MONTAGE

1

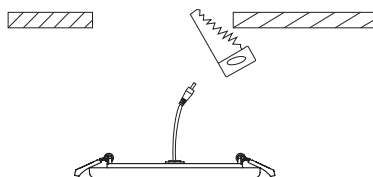

Schneiden Sie ein Loch mit der richtigen Größe. Siehe Seite 10 für die Abmessungen.

2

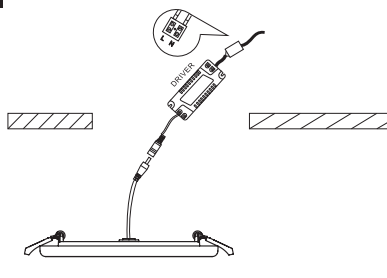

Schließen Sie das Netzkabel an den Treiber an. Verbinden Sie den Stecker des Treibers mit dem Stecker der Leuchte.

3

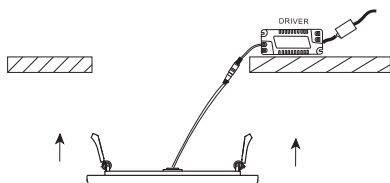

4



NL

EN

FR

CZ

DE

PROLUMIA®

IMPORTER

NEDELKO B.V.

Riga 10

2993 LW BARENDRECHT

T +31 (0)180 64 54 00

E info@nedelko.nl

NEDELKO BELGIUM NV

Prins Boudewijnlaan 49

2650 EDEGEM

T +32 (0)3 826 99 99

E info@nedelko.be

NEDELKO S.R.O.

Ke Slivenci 48

154 00 PRAHA 5 - LOCHKOV

T +420 222 563 003

E info@nedelko.cz

NEDELKO GERMANY GMBH

Feldbergstraße 57

61440 OBERURSEL

T +49 6171 8989 594

E info@nedelko.de