

All brand and product names are trademarks or registered trademarks of their respective owners.

Service

For service and support, please contact your local sales organization.

[Eaton.com/contacts](https://www.eaton.com/contacts)

[Eaton.com/aftersales](https://www.eaton.com/aftersales)

Original operating manual

The German-language edition of this document is the original operating manual.

Translation of the original operating manual

All editions of this document other than those in German language are translations of the original operating manual.

3rd Edition 2025, publication date 11/25

See revision protocol in the chapter "About this manual".

© 2019 by Eaton Industries GmbH, 53105 Bonn, Germany

All rights, including those of translation, reserved.

No part of this manual may be reproduced, stored in a retrieval system, or transmitted in any form or by any means, electronic, mechanical, photocopying, micro-filming, recording, or otherwise, without the prior written permission of Eaton Industries GmbH, Bonn, Germany.

Subject to alteration.



Danger! **Dangerous electrical voltage!**

Before commencing the installation

- Disconnect the power supply of the device.
- Ensure that devices cannot be accidentally restarted.
- Verify isolation from the supply.
- Earth and short circuit.
- Cover or enclose neighbouring units that are live.
- Follow the engineering instructions (AWA/IL) of the device concerned.
- Only suitably qualified personnel in accordance with EN 50110-1/-2 (VDE 0105 Part 100) may work on this device/system.
- Before installation and before touching the device ensure that you are free of electrostatic charge.
- The functional earth (FE) must be connected to the protective earth (PE) or to the potential equalisation. The system installer is responsible for implementing this connection.
- Connecting cables and signal lines should be installed so that inductive or capacitive interference does not impair the automation functions.
- Install automation devices and related operating elements in such a way that they are well protected against unintentional operation.
- Suitable safety hardware and software measures should be implemented for the I/O interface so that a line or wire breakage on the signal side does not result in undefined states in the automation devices.
- Ensure a reliable electrical isolation of the low voltage for the 24 volt supply. Only use power supply units complying with IEC 60364-4-41 (VDE 0100 Part 410) or HD 384.4.41 S2.
- Deviations of the mains voltage from the rated value must not exceed the tolerance limits given in the specifications, otherwise this may cause malfunction and dangerous operation.
- Emergency stop devices complying with IEC/EN 60204-1 must be effective in all operating modes of the automation devices. Unlatching the emergency-stop devices must not cause restart.
- Devices that are designed for mounting in housings or control cabinets must only be operated and controlled after they have been installed with the housing closed. Desktop or portable units must only be operated and controlled in enclosed housings.
- Measures should be taken to ensure the proper restart of programs interrupted after a voltage dip or failure. This should not cause dangerous operating states even for a short time. If necessary, emergency-stop devices should be implemented.
- Wherever faults in the automation system may cause damage to persons or property, external measures must be implemented to ensure a safe operating state in the event of a fault or malfunction (for example, by means of separate limit switches, mechanical interlocks etc.).

Content

0	About This Manual.....	3
0.1	List of revisions	3
0.2	Target group.....	3
0.3	Additional documents	3
0.4	Abbreviations and symbols	4
0.4.1	Risk of material damage.....	4
0.4.2	Hazard warnings of personal injury	4
0.4.3	Tips.....	4
1	Safety notes.....	5
2	Description.....	6
3	Operating and indication elements.....	7
4	Basic circuit diagram	8
5	Derating	9
6	Diagnostics	10
7	Application examples	11
7.1	Two-hand control systems with equality monitoring < 0.5 s and monitored contact extension, correspond to ISO 13851 Typ IIIC, suitable up to Safety Category 4	11
7.2	Monitoring of controlling, disabling protective devices according to EN ISO 14119 with simultaneity monitoring < 0.5 s, suitable up to Safety Category 4.....	11
8	Technical data	12
9	Glossary	15

0 About This Manual

This manual applies to the ESR5-NZ-21-24VAC-DC safety relay.

0.1 List of revisions

The following significant amendments have been introduced since previous issues:

Publication date	Page	Keyword	new	modified	deleted
12/19		First edition	–	–	–
07/20	3,7,12	EN 574 Typ IIIC replaced by ISO13851 Typ IIIC	–	✓	–
11/25	6,11,14	Re-certification EN IEC 62061 SII, CLaim Limit removed	–	–	✓

0.2 Target group

This manual is intended for qualified personnel installing, operating, and maintaining the ESR5-NZ-21-24VAC-DC safety relay.



CAUTION

Installation requires a qualified electrician

0.3 Additional documents

For further information, see the following documentation:

- Instruction leaflet IL05013030Z
- Safety relay data sheet ESR5-NZ-21-24VAC-DC, article no. 118703

WARNING

Make sure you always use the latest documentation.
It can be downloaded from the product at: Eaton.com/esr5

0.4 Abbreviations and symbols

The symbols used in this manual have the following meanings:

- ▶ indicates actions to be taken.

0.4.1 Risk of material damage

WARNING

Warns about the possibility of material damage.

0.4.2 Hazard warnings of personal injury



CAUTION

Warns of the possibility of hazardous situations that may possibly cause slight injury.



WARNING

Warns of the possibility of hazardous situations that could result in serious injury or even death.



DANGER

Warns of hazardous situations that result in serious injury or death.

0.4.3 Tips



Indicates useful tips.

1 Safety notes



WARNING

Risk of electric shock

During operation, parts of electrical switching devices carry hazardous voltages.

Before working on the switching device, disconnect the power. Please observe the safety regulations of electrical engineering and industrial safety and liability associations!

Disregarding these safety regulations may result in death, serious personal injury or damage to equipment.

Startup, mounting, modifications, and upgrades should only be carried out by a skilled electrical engineer!



WARNING

Risk of automatic machine restart!

For emergency stop applications, the machine must be prevented from restarting automatically by a higher-level control system.

Protective covers must not be removed when operating electrical switching devices.



WARNING

Danger due to faulty devices!

The devices may be damaged following an error and correct operation can no longer be ensured.

In the event of an error, replace the device immediately.

Repairs to the device, especially if the housing must be opened, may only be carried out by the manufacturer or authorized persons. Otherwise the warranty is invalidated.

CAUTION

Risk of damage to equipment due to incorrect installation

For reliable operation, the safety relay must be installed in housing protected from dust and humidity (IP54).

Carry out wiring according to the application.

Refer to the "Application examples" section for this.

CAUTION

Risk of damage to equipment due to noise emissions

When operating relay modules the operator must meet the requirements for noise emission for electrical and electronic equipment (EN 61000-6-4) on the contact side and, if required, take appropriate measures.

2 Description

The ESR5-NZ-21-24VAC-DC safety relay can be used to monitor two-hand control devices according to ISO 13851 Typ IIIC and safety doors.

External contactors or extension modules are monitored.

It monitors simultaneity of both inputs in < 0.5 seconds.

With this switching device, circuits are interrupted in a safety-oriented manner.

Control is via two channels.

Depending on the external wiring, up to category 4, PL e according to EN ISO 13849-1 or SIL 3 according to EN 62061 can be achieved.

The safety relay is equipped with two enabling current paths and one signaling current path that drop out without delay according to stop category 0.

Features

- Two-hand control systems with equality monitoring < 0.5 s, corresponds to ISO 13851 Typ IIIC, suitable for up to Safety Category 4.
- Safety door monitoring
- Suitable up to category 4, PL e (EN ISO 13849-1), SIL 3 (EN 62061)
- Two-channel wiring
- Automatic or manual start circuit
- Screw terminal blocks

3 Operating and indication elements

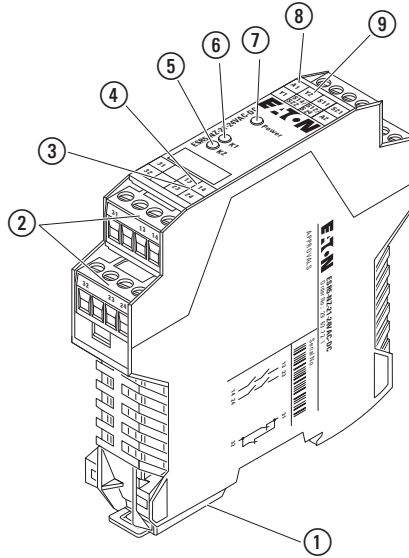

Figure 1: ESR5-NZ-21-24VAC-DC

- ① Metal lock for mounting on the DIN rail
- ② COMBICON plug-in screw terminal blocks
- ③ 31/32 - signaling current path
- ④ 13/14, 23/24 - undelayed enabling current paths
- ⑤ LED status indicator, green - K2
- ⑥ LED status indicator, green - K1
- ⑦ LED status indicator, green - Power
- ⑧ A1, A2 - supply voltage connection
- ⑨ Y1, Y2, S11, S21, S12, S24, S14, S22 - input circuits

4 Basic circuit diagram

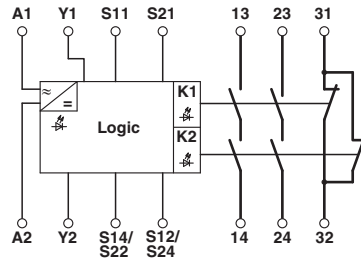

Figure 2: Block diagram

Designation	Explanation
A1/A2	Safety relay input voltage
Y1/Y2	
S11/S21	Sensor circuit
S12/S24	
S14/S22	
13/14	Undelayed enabling current path 1
23/24	Undelayed enabling current path 2
31/32	Signaling current path

5 Derating

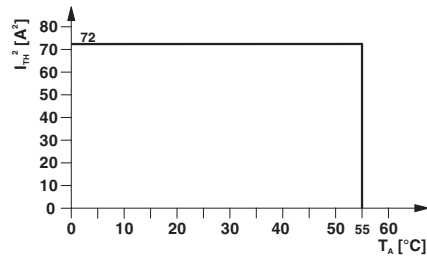

Figure 3: Derating curve

6 Diagnostics

○ – LED off

● – LED on

Table 1: Diagnostic description

	Power	K1	K2	Fault	Remedy
Connection/ voltage error	○	○	○	Supply voltage not present.	Apply supply voltage.
	●	○	●	Supply voltage too low.	Adjust supply voltage.
	●	○	○	The enable circuits are connected incorrectly or not connected at all.	Check the connection of the enable circuits.
	●	○	○	No bridge between Y1 and Y2.	Insert bridge.
Cross-circuit	○	○	○	Between enable circuits S11-S14/S12 and S21-S24/S22.	Remove cross-circuit.
Short circuit	○	○	○	Between contact points A1 and A2.	Remove short circuit.
	●	○	○	Between S11 and S12 or S11 and S14. Fault detection on next demand.	
	●	○	○	Between S21 and S22 or S21 and S24. Fault detection on next demand.	
Fault with internal cause	●	○	●	Enable contact(s) of K1 faulty.	Replace safety relays.
	●	●	○	Enable contact(s) of K2 faulty.	
	●	○	○	Enable contact(s) of K1 and K2 faulty.	

7 Application examples

7.1 Two-hand control systems with equality monitoring < 0.5 s and monitored contact extension, correspond to ISO 13851 Typ IIIC, suitable up to Safety Category 4

Suitable up to category 4, PL e (EN ISO 13849-1), SIL 3 (EN 62061)

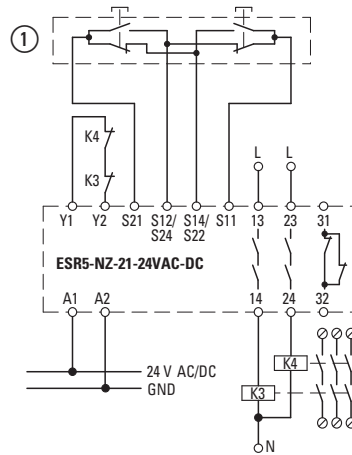

Figure 4: Two-hand control device

① Two-hand control device

7.2 Monitoring of controlling, disabling protective devices according to EN ISO 14119 with simultaneity monitoring < 0.5 s, suitable up to Safety Category 4

Suitable up to category 4, PL e (EN ISO 13849-1), SIL 3 (EN 62061)

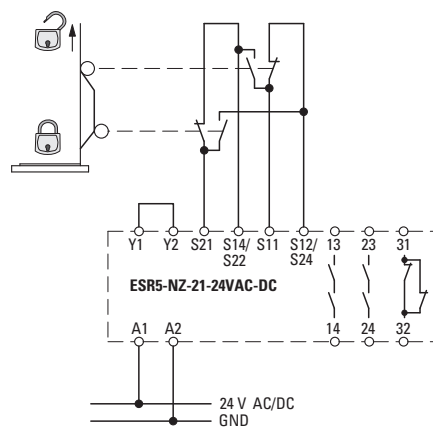





Figure 5: Guard - two-channel

8 Technical data

Input data	
Nominal input voltage U_N	24 V AC/DC
Input voltage range (factor)	0.85 - 1.1
Typical input current	125 mA AC 60 mA DC
Voltage at input/start and feedback circuit	~ 24 V DC
Typical response time	50 ms
Typical release time	20 ms
Recovery time	1 s
Operating voltage display	LED, green
Status display	LED, green
Protective circuit	Fuse PTC resistor
Output data	
Contact type	2 enabling current paths 1 signaling current path
Contact material	AgSnO ₂ + 0,2 μm Au
Minimum switching voltage	15 V AC/DC
Maximum switching voltage	250 V AC/DC
Limiting continuous current	6 A
Maximum inrush current	6 A
Inrush current, minimum	25 mA
Interrupting rating (ohmic load) max.	144 W (24 V DC, τ = 0 ms) 288 W (48 V DC, τ = 0 ms) 110 W (110 V DC, τ = 0 ms) 88 W (220 V DC, τ = 0 ms) 1500 VA (250 V AC, τ = 0 ms)
Maximum interrupting rating (inductive load)	42 W (24 V DC, τ = 40 ms) 42 W (48 V DC, τ = 40 ms) 42 W (110 V DC, τ = 40 ms) 42 W (220 V DC, τ = 40 ms)
Switching capacity min.	0.4 W
Mechanical service life	~ 10 ⁷ cycles
Switching capacity (360 cycles/h)	4 A (24 V DC) 4 A (230 V AC)
Switching capacity (3600 cycles/h)	2.5 A (24 V (DC-13)) 3 A (230 V (AC-15))
Output fuse	10 A gL/gG NEOZED (N/O contact) 6 A gL/gG NEOZED (N/C contact)
General data	
Relay type	Electromechanically forcibly guided, dust-proof relay
Nominal operating mode	100 % operating factor
Degree of protection	IP20
Min. degree of protection of inst. location	IP54

Mounting position	any
Mounting type	DIN rail mounting
Air and creepage distances between the power circuits	DIN EN 50178/VDE 0160
Rated insulation voltage	250 V
Rated surge voltage / insulation	6 kV (Safe isolation, increased insulation)
Dimensions	
W x H x D	22.5 x 99 x 114.5 mm
Connection data	
Conductor cross section, solid	0.2 mm ² - 2.5 mm ²
Conductor cross section, stranded	0.2 mm ² - 2.5 mm ²
Conductor cross section AWG/kcmil	24 - 12
Stripping length	7 mm
Ambient conditions	
Ambient temperature (operation)	-20 °C - 55 °C
Ambient temperature (storage/transport)	-40 °C - 70 °C
Max. permissible relative humidity (operation)	75 %
Max. permissible humidity (storage/transport)	75 %
Certification / Approvals	
Approvals	   <div style="display: inline-block; vertical-align: middle; text-align: left; margin-left: 10px;"> Product Safety Functional Safety <small>www.tuv.com ID 060000000</small> </div>
Safety data	
Stop category according to IEC 60204	0
Safety parameters for IEC 61508 - High demand	
SIL	3
PFH _d	5.05 x 10 ⁻¹⁰
Demand rate	< 12 months
Proof test interval	240 months
Duration of use	240 months
Safety parameters for IEC 61508 - Low demand	
SIL	3
MTTF _d	72601 years
PFD _{avg}	1.35 x 10 ⁻⁴
Proof test interval	240 months
Safety characteristic data according to EN ISO 13849	
Category	4
Performance Level	e
DC _{avg}	97.75 %
CCF	passed

8 Technical data

9 Glossary

Abbreviation	Description
AC-15, DC-13	Standardized utilization categories and load cases from standard IEC 60947-5-1 that are used to test switching elements, i.e., switching on and off with defined voltages, currents, and loads (electromagnetic loads in particular in this case).
AOPD	Active Opto-electronic Protective Device Device with a sensor function that is implemented with optoelectronic transmission and reception elements that detect when an opaque object in the defined area of protection (or in the way of the light beam axis in the case of light barriers) is blocking the beams generated by the device. AOS is used as an abbreviation synonymous with AOPD in DIN EN 692 ("Machine tools - Mechanical presses - Safety"), DIN EN 693 ("Machine tools - Safety - Hydraulic presses"), and EN 12622 ("Safety of machine tools - Hydraulic press brakes").
AOPDDR	Active Opto-electronic Protective Device responsive to Diffuse Reflection Device with a sensor function that is implemented with optoelectronic transmission and reception elements that detect when an object in the area of protection defined with two dimensions diffusely reflects the beam generated by the device.
ESPE	Electro-sensitive protective equipment
CCF	Common Cause Failure Common cause failure
DC	Diagnostic Coverage Diagnostic coverage
ESR	Electronic safety relay
DF	Duty factor
PL	Performance Level Classification of safety functions used to meet a safety requirement.
HFT	Hardware Fault Tolerance
Cat. / category	Classification of resistance to errors as defined in EN ISO 13849-1
Mission Time T_M	Lifetime
MTTF / $MTTF_d$	Mean Time To Failure Mean time to failure / mean time to dangerous failure
NC	Normally Closed contact, break contact An NC breaks a circuit when it is energized.
NO	Normally-Open contact An NO closes when it is energized.
PFD	Probability Failure on Demand (Low-Demand) Probability of failure relative to the number of requests
PFH_d	Probability of a Dangerous Failure per Hour Probability of dangerous Failures per Hour
SIL	Safety Integrity Level Safety integrity level
SRCF	Safety-Related Control Function Safety-related control function
SRECS	Safety-Related Electrical Control System Safety related electrical, electronic, programmable electronic control system
SRP	Safety-Related Part Safety-related part
SRP/CS	Safety-Related Parts of Control System Safety-related part of a control system

Eaton is an intelligent power management company dedicated to protecting the environment and improving the quality of life for people everywhere. We make products for the data center, utility, industrial, commercial, machine building, residential, aerospace and mobility markets. We are guided by our commitment to do business right, to operate sustainably and to help our customers manage power – today and well into the future.

By capitalizing on the global growth trends of electrification and digitalization, we're helping to solve the world's most urgent power management challenges and building a more sustainable society for people today and generations to come.

For more information, visit [Eaton.com](https://www.eaton.com).