

Walraven RapidRail Construction Bracket (zp)

(G2015)

to make Walraven RapidRail® fabrications

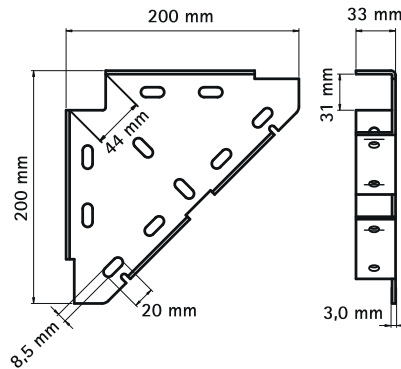

Features & benefits

- one-part support
- for fixing support under, top or on side of a cantilever arm
- also used to strengthen rail constructions
- suitable for rail WM0, 1, 15, 2, 30
- material: steel
- zinc plated
- Rail Junction Angle Bracket for 38x40 Rail: See Part No. 65938020 (page H 16 20).

Product Number Total Width x Total Height x Total Depth

Reference letter	W x H x D/T
Unit description	mm x mm x mm
6593010	200 x 33 x 200