

ESR5-NV3-30

Electronic safety relay for emergency stop and safety door monitoring



Powering Business Worldwide

All brand and product names are trademarks or registered trademarks of their respective owners.

Service

For service and support, please contact your local sales organization.

[Eaton.com/contacts](https://www.eaton.com/contacts)

[Eaton.com/aftersales](https://www.eaton.com/aftersales)

Original operating manual

The German-language edition of this document is the original operating manual.

Translation of the original operating manual

All editions of this document other than those in German language are translations of the original operating manual.

2nd Edition 2025, publication date 11/25

See revision protocol in the chapter "About this manual".

© 2019 by Eaton Industries GmbH, 53105 Bonn, Germany

All rights, including those of translation, reserved.

No part of this manual may be reproduced, stored in a retrieval system, or transmitted in any form or by any means, electronic, mechanical, photocopying, micro-filming, recording, or otherwise, without the prior written permission of Eaton Industries GmbH, Bonn, Germany.

Subject to alteration.



Danger! **Dangerous electrical voltage!**

Before commencing the installation

- Disconnect the power supply of the device.
- Ensure that devices cannot be accidentally restarted.
- Verify isolation from the supply.
- Earth and short circuit.
- Cover or enclose neighbouring units that are live.
- Follow the engineering instructions (AWA/IL) of the device concerned.
- Only suitably qualified personnel in accordance with EN 50110-1/-2 (VDE 0105 Part 100) may work on this device/system.
- Before installation and before touching the device ensure that you are free of electrostatic charge.
- The functional earth (FE) must be connected to the protective earth (PE) or to the potential equalisation. The system installer is responsible for implementing this connection.
- Connecting cables and signal lines should be installed so that inductive or capacitive interference does not impair the automation functions.
- Install automation devices and related operating elements in such a way that they are well protected against unintentional operation.
- Suitable safety hardware and software measures should be implemented for the I/O interface so that a line or wire breakage on the signal side does not result in undefined states in the automation devices.
- Ensure a reliable electrical isolation of the low voltage for the 24 volt supply. Only use power supply units complying with IEC 60364-4-41 (VDE 0100 Part 410) or HD 384.4.41 S2.
- Deviations of the mains voltage from the rated value must not exceed the tolerance limits given in the specifications, otherwise this may cause malfunction and dangerous operation.
- Emergency stop devices complying with IEC/EN 60204-1 must be effective in all operating modes of the automation devices. Unlatching the emergency-stop devices must not cause restart.
- Devices that are designed for mounting in housings or control cabinets must only be operated and controlled after they have been installed with the housing closed. Desktop or portable units must only be operated and controlled in enclosed housings.
- Measures should be taken to ensure the proper restart of programs interrupted after a voltage dip or failure. This should not cause dangerous operating states even for a short time. If necessary, emergency-stop devices should be implemented.
- Wherever faults in the automation system may cause damage to persons or property, external measures must be implemented to ensure a safe operating state in the event of a fault or malfunction (for example, by means of separate limit switches, mechanical interlocks etc.).

Content

0	About This Manual	3
0.1	List of revisions	3
0.2	Target group.....	3
0.3	Additional documents	3
0.4	Abbreviations and symbols	4
0.4.1	Risk of material damage.....	4
0.4.2	Hazard warnings of personal injury	4
0.4.3	Tips.....	4
1	Safety notes	5
2	Description	7
3	Operating and indication elements	8
3.1	LED status indicators	9
4	Basic circuit diagram	10
5	Derating	11
6	Configuration	12
6.1	Setting the delay time	12
6.2	Protection against manipulation	13
7	Timing Diagrams	14
7.1	Configuring the time delay	14
7.2	Manually monitored reset (S34)	15
7.3	Automatic reset (S35)	15
8	Operating modes	16
8.1	Two-channel with cross-circuit monitoring via clock outputs.....	16
8.2	Two-channel with cross-circuit monitoring via external clock signals	17
8.3	Two-channel without cross-circuit monitoring	18
8.4	Single-channel without cross-circuit monitoring	18
8.5	Automatic start circuit	19
8.6	Manual start circuit.....	19
9	Diagnistics	20
10	Application examples	21

10.1	Two-channel emergency stop circuit with DA1 variable frequency drive	21
10.2	Two-channel safety door monitoring with dropout delayed contacts and automatic reset (with cross-circuit detection)	23
11	Cable lengths	24
12	Proof test	25
13	Technical data	26
14	Glossary	29

0 About This Manual

This manual applies to the ESR5-NV3-30 safety relay.

0.1 List of revisions

The following significant amendments have been introduced since previous issues:

Publication date	Page	Keyword	new	modified	deleted
12/19		First edition	–	–	–
11/25	7,21,29	Re-certification EN IEC 62061 SII, CLaim Limit removed	–	–	✓

0.2 Target group

This manual is intended for qualified personnel installing, operating, and maintaining the ESR5-NV3-30 safety relay.



CAUTION

Installation requires a qualified electrician

0.3 Additional documents

For further information, see the following documentation:

- Instruction leaflet IL05013033Z
- Safety relay data sheet ESR5-NV3-30, article no. 118705

WARNING

Make sure you always use the latest documentation.

It can be downloaded from the product at: www.eaton.com/esr5

0.4 Abbreviations and symbols

The symbols used in this manual have the following meanings:

- ▶ indicates actions to be taken.

0.4.1 Risk of material damage

CAUTION

Warns about the possibility of material damage.

0.4.2 Hazard warnings of personal injury



CAUTION

Warns of the possibility of hazardous situations that may possibly cause slight injury.



WARNING

Warns of the possibility of hazardous situations that could result in serious injury or even death.



DANGER

Warns of hazardous situations that result in serious injury or death.

0.4.3 Tips



Indicates useful tips.

1 Safety notes



WARNING

Risk of electric shock

During operation, parts of electrical switching devices carry hazardous voltages.

Before working on the switching device, disconnect the power. Please observe the safety regulations of electrical engineering and industrial safety and liability associations!

Disregarding these safety regulations may result in death, serious personal injury or damage to equipment.

Startup, mounting, modifications, and upgrades should only be carried out by a skilled electrical engineer!



WARNING

Risk of automatic machine restart!

For emergency stop applications, the machine must be prevented from restarting automatically by a higher-level control system.

Protective covers must not be removed when operating electrical switching devices.



WARNING

Danger due to faulty devices!

The devices may be damaged following an error and correct operation can no longer be ensured.

In the event of an error, replace the device immediately.

Repairs to the device, especially if the housing must be opened, may only be carried out by the manufacturer or authorized persons. Otherwise the warranty is invalidated.

CAUTION

Risk of damage to equipment due to incorrect installation

For reliable operation, the safety relay must be installed in housing protected from dust and humidity (IP54).

Carry out wiring according to the application.

Refer to the "Application examples" section for this.

1 Safety notes

CAUTION

Risk of damage to equipment due to noise emissions

When operating relay modules the operator must meet the requirements for noise emission for electrical and electronic equipment (EN 61000-6-4) on the contact side and, if required, take appropriate measures.

CAUTION

Electronics may be damaged when overloaded

Take measures outside the device to limit transient surge voltages to the respective value for surge voltage category II.

2 Description

The ESR5-NV3-30 safety relay can be used for emergency stop and light grid/safety door monitoring as well as in safety circuits according to DIN EN 60204-1.

With this switching device, circuits are interrupted in a safety-oriented manner. Single-channel or two-channel control is available, either with an automatic or a manual start circuit. A connected reset button (connected to S33/S34) is monitored.

Depending on the external wiring, up to category 4, PL e according to EN ISO 13849-1 or SIL 3 according to EN 62061 can be achieved.

The safety relay has two enabling current paths that drop out without delay according to stop category 0. Two other enabling current paths drop out with a delay in compliance with stop category 1.

Features

- Emergency stop, safety door and light grid monitoring
- Suitable up to category 4, PL e (EN ISO 13849-1), SIL 3 (EN 62061)
- Single-channel or two-channel wiring with cross-circuit detection
- Two undelayed and two off-delay enable contacts
- Delay time can be progressively preset (0.1 s ... 30 s)
- Automatic or manual start circuit
- Screw terminal blocks

3 Operating and indication elements

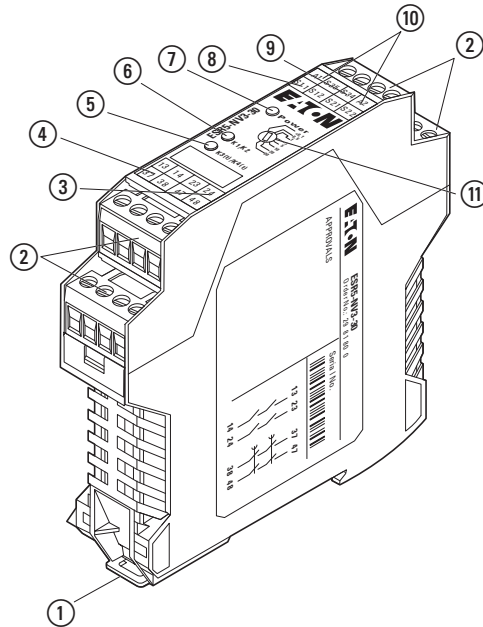

Figure 1: ESR5-NV3-30

- ① Metal lock for mounting on the DIN rail
- ② COMBICON plug-in screw terminal blocks
- ③ 13/14, 23/24 - undelayed enabling current paths
- ④ 37/38, 47/48 - delayed enabling current paths
- ⑤ LED status indicator, green - K3(t)/K4(t)
- ⑥ LED status indicator, green - K1/K2
- ⑦ LED status indicator, green - Power
- ⑧ S11, S12, S21, S22 – input circuits
- ⑨ S34, S35 - start circuits
- ⑩ A1, A2 - supply voltage connection
- ⑪ Rotary switch, delay time 0.1 s - 30 s

3.1 LED status indicators

Power	K1/K2	K3(t)/K4(t)	Meaning	Measure/remedy in the event of an error
ON	OFF	OFF	Ready to operate	Safety relay is ready to operate
ON	ON	ON	Operating	Safety relay is active. The enabling current paths are closed.
Flashes 0.2 s	OFF	OFF	Internal error	Safety relay is faulty. Replace the safety relay.
Flashes 1 s	OFF	OFF	External error	Check the wiring and the operating voltage supply. In the case of a manual reset: Check the chronological sequence!
Flashes 1 s	Flashes 1 s	OFF	Configuration errors	An error occurred during configuration. Check the wiring and operation. Then carry out configuration again in accordance with Section 9.
Flashes 1 s	Flashes 1 s	Flashes 1 s	Configuration required	Rotary switch has been modified. Carry out configuration again in accordance with Section 9.

4 Basic circuit diagram

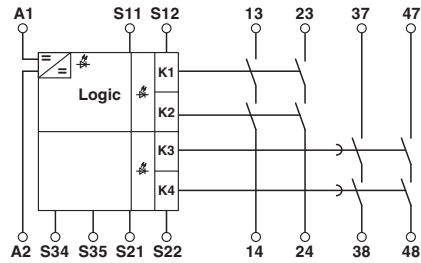

Figure 2: Block diagram

Designation	Explanation
A1/A2	Safety relay input voltage
S11/S12	Safety sensor/switch 1 input circuit
S21/S22	Safety sensor/switch 2 input circuit
S34/S35	Start circuit
13/14	Undelayed enabling current path 1
23/24	Undelayed enabling current path 2
37/38	Delayed enabling current path 1
47/48	Delayed enabling current path 2

5 Derating

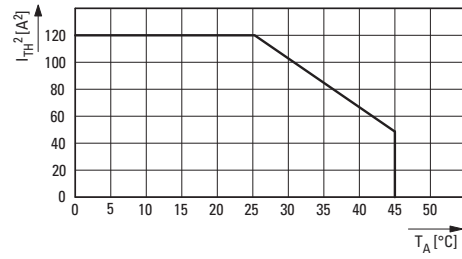

Figure 3: Derating curve

6 Configuration



Once configuration is complete, close the four enable current paths and the Power, K1/K2 and K3(t)/K4(t) LEDs are illuminated.

Configuration of the safety relay

To configure the safety relay, proceed as follows:

- ▶ Disconnect the safety relay from the supply voltage.
- ▶ Set the delay time (1 s - 30 s) at the rotary switch.
- ▶ Restore the power supply.
- ▶ Close the emergency stop circuits.
- ▶ In the case of a **manual start**: Press the reset button.
- ▶ **Automatic start circuit**: Wait for the configured delay time until the enabling current paths are closed and the Power LED lights up.
- ▶ **Manual start circuit**: Wait for the configured delay time and press the reset button until the enabling current paths are closed and the Power LED lights up.



WARNING

Danger due to incorrect delay time

Check the set delay time following installation!

6.1 Setting the delay time

The delay time is set progressively between 0.1 s and 30 s via the rotary switch in the upper housing part.



If the rotary switch is modified during operation, the safety relay switches to configuration mode and the LEDs flash. The safety relay is only ready for operation again once the supply voltage has been switched off and on again and configuration has been carried out.

6.2 Protection against manipulation

Once the time has been set, the rotary switch can be protected against manipulation by covering with the label provided.

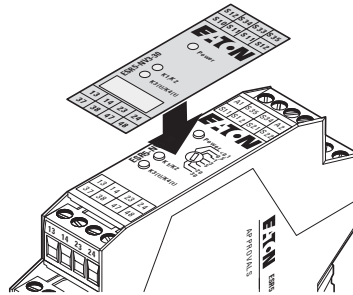

Figure 4: Applying the label

7 Timing Diagrams

7.1 Configuring the time delay

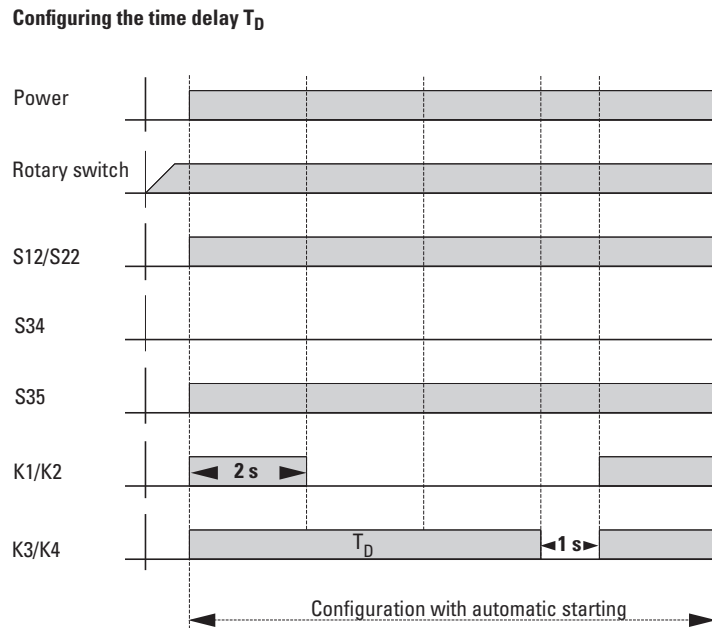

Figure 5: Configuring the time delay

7.2 Manually monitored reset (S34)

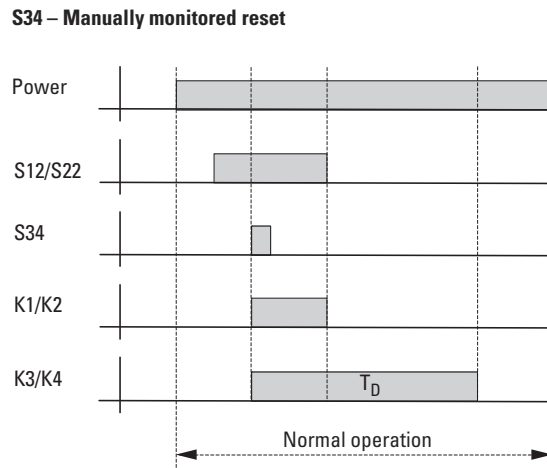

Figure 6: Manually monitored reset

7.3 Automatic reset (S35)

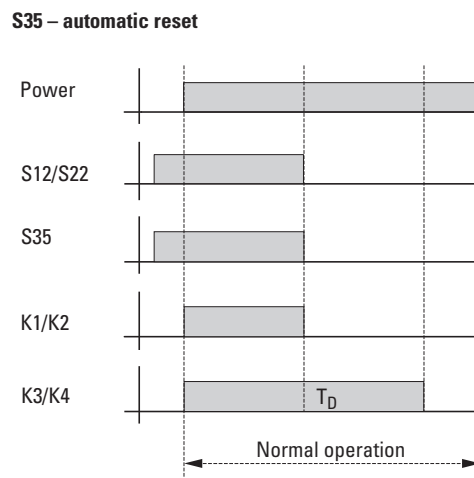

Figure 7: Automatic reset

8 Operating modes

8.1 Two-channel with cross-circuit monitoring via clock outputs

If digital inputs S12 and S22 are controlled with the output signal of digital outputs S11 and S21, the emergency stop circuits are monitored for cross circuits by the safety relay.



After the safety function has been triggered by the opening of an emergency stop circuit, both emergency stop circuits must be opened once at the same time before it is possible to reset the enabling current paths.

If this condition is not met, the device signals an external error.

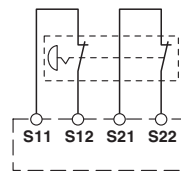

Figure 8: Cross-circuit monitoring

Signal form of the clock outputs

The following figure shows the signal form of clock outputs S11 and S22.

To ensure correct function of the application, the signals must not be smoothed too greatly by the capacitive and inductive behavior of the cable.

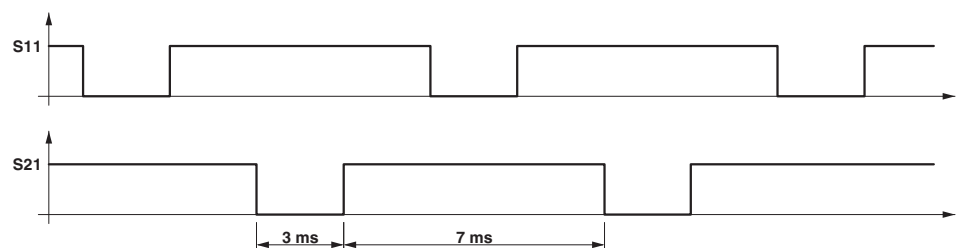

Figure 9: Signal form of the clock outputs

8.2 Two-channel with cross-circuit monitoring via external clock signals

If digital inputs S12 and S22 are controlled with the output signals of a safe PLC or API safe, the emergency stop circuits are monitored for cross circuits by the external clock signals.

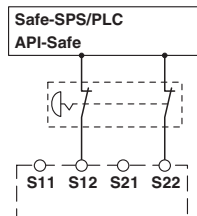

Figure 10: Cross-circuit monitoring via external clock signals

Permitted signal form for light grid, safe PLC, and API safe

The following figure shows the permitted signal forms for external clock signals at inputs S12 and S22.

The following applies to the high signal:

- The blanking intervals must not exceed 1 ms.
- The time between the blanking intervals must be no less than 10 ms.

The following applies to the low signal:

- The pulses must not exceed 1 ms.
- The time between two pulses must be no less than 10 ms.

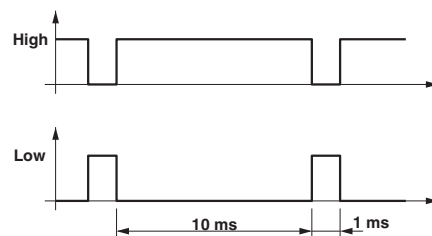

Figure 11: Permitted signal form for light grid, safe PLC, and API safe

8.3 Two-channel without cross-circuit monitoring

As an option, the two digital inputs S12 and S22 can be activated with a static 24 V DC signal. However, cross-circuit monitoring will no longer be available.

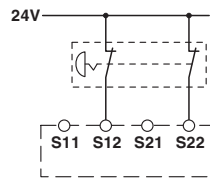

Figure 12: Two-channel without cross-circuit monitoring

8.4 Single-channel without cross-circuit monitoring

Digital inputs S12 and S22 can be connected via a 24 V connection. This application is not "single-fault tolerant".

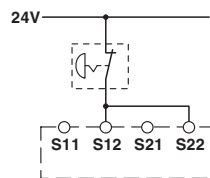

Figure 13: Single-channel without cross-circuit detection

8.5 Automatic start circuit

- ▶ Connect S35 to A1.

The enabling current paths close automatically when the power supply is switched on with closed emergency stop circuits.



After the emergency stop, the enabling current paths close automatically when the emergency stop circuits are closed. This also applies if the emergency stop circuits are closed before the delay time has elapsed.

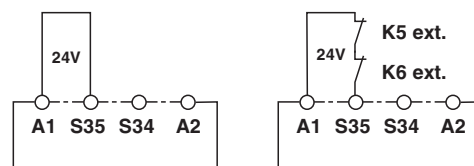

Figure 14:Automatic start circuit

8.6 Manual start circuit

- ▶ Connect S34 to A1 via a button or an enabling contact or use a PLC output for control.

Monitoring of input S34 prevents the enabling current paths from closing in the following situations:

- Digital input S34 at HIGH level when switching on the power supply.
- Digital input S34 does not switch to LOW level on demand and before the set delay time has elapsed.
- Digital input S34 at HIGH level when closing the emergency stop circuits.
- Manual and automatic start circuit simultaneously at HIGH level.

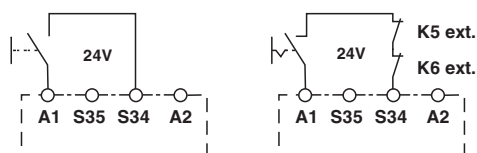

Figure 15:Manual start circuit

9 Diagnostics

○ – LED off

● – LED flashes

Table 1: Diagnostic description

	Power	K1/K2	K3(t)/K4(t)	Fault	Remedy
Connection/ voltage error	○	○	○	Supply voltage not present.	Apply supply voltage.
	★	○	○	Supply voltage too low.	Adjust supply voltage.
	★ 1 s	○	○	Supply voltage too high.	Adjust supply voltage.
	★	○	○	The enable circuits are connected incorrectly or not connected at all.	Check the connection of the enable circuits.
Cross-circuit	★ 1 s	○	○	Between both enable circuits S11-S12 and S21-S22. E.g., for emergency stop or safety door.	Remove cross-circuit.
	★	○	○	Between enable circuit S12-S22 for applications with light grid and safe PLC. Fault is detected and indicated by the light grid/PLC.	
Short circuit	○	○	○	Between contact points A1 and A2.	Remove short circuit.
	★ 1 s	○	○	Between S11 and S12. Error detection on next demand.	
	★ 1 s	○	○	Between S21 and S22. Fault detection on next demand.	
Fault in reset circuit	★ 1 s	○	○	Faulty reset button. Short circuit between A1 and S34. No fault detection on initial start, only once all enable contacts have been opened.	Remove short circuit.
Configuration error	★ 1 s	★ 1 s	○	If a cross-circuit or overvoltage/undervoltage occurs during the configuration phase, the safety module indicates a configuration error.	Check the wiring and the operating voltage supply. Perform a voltage reset.
	★ 1 s	★ 1 s	★ 1 s	Rotary switch (delay time) was modified.	Perform configuration again.
Fault with internal cause	★ 0,2 s	○	○	Safety relay faulty.	Replace safety relays. Perform a voltage reset.
	★ 0,2 s	○	○	Enable contact(s) of K1 and K2 faulty.	
	★ 0,2 s	○	○	Enable contact(s) of K3 and K4 faulty.	

10 Application examples

10.1 Two-channel emergency stop circuit with DA1 variable frequency drive

Application

- The SS1 function can be used to shut down drives in a controlled manner if a braking ramp is used. The STO function can then either be activated after a set delay time or once the drive has come to a standstill (stop category 1). The SS1 function is purely functional and is therefore not classified as safety-related.
- The STO function may also be used in machines with electronically controlled drives.
- Suitable up to category 3, PL d (EN ISO 13849-1), SIL 2 (EN 62061)



The emergency-stop function is an additional safety function. It may not be used as the sole means of protection!

Conditions

- Emergency-stop buttons with positive-opening contacts (IEC 60947-5-1 Appendix K), in accordance with EN ISO 13850.
- Use safety relays with positive-opening contacts.
- Install the emergency-stop buttons outside the hazardous area and in a place where they are clearly visible.
- Only start hazardous motion after a separate reset.
- Test the emergency-stop function once every quarter.
- Ensure compliance with any additional applicable standards, e.g. IEC 60204-1.
- Use a twisted and screened cable for the power supply to STO+ and STO-.
- Route the supply cable through a covered cable duct.
- Ensure that the braided screening (PES) is grounded.
- The DA1 variable frequency drive and the safety relay must be configured in line with the requirements of the application at hand.
- The ramp time of the selected DA1 variable frequency drive must be shorter than the delay time of the safety relay.

Features

- Design based on proven components and safety principles (EN ISO 13849-1 and EN ISO 13849-2).
- The piloted device, input wiring and command processing are redundant and self-monitoring.

10 Application examples

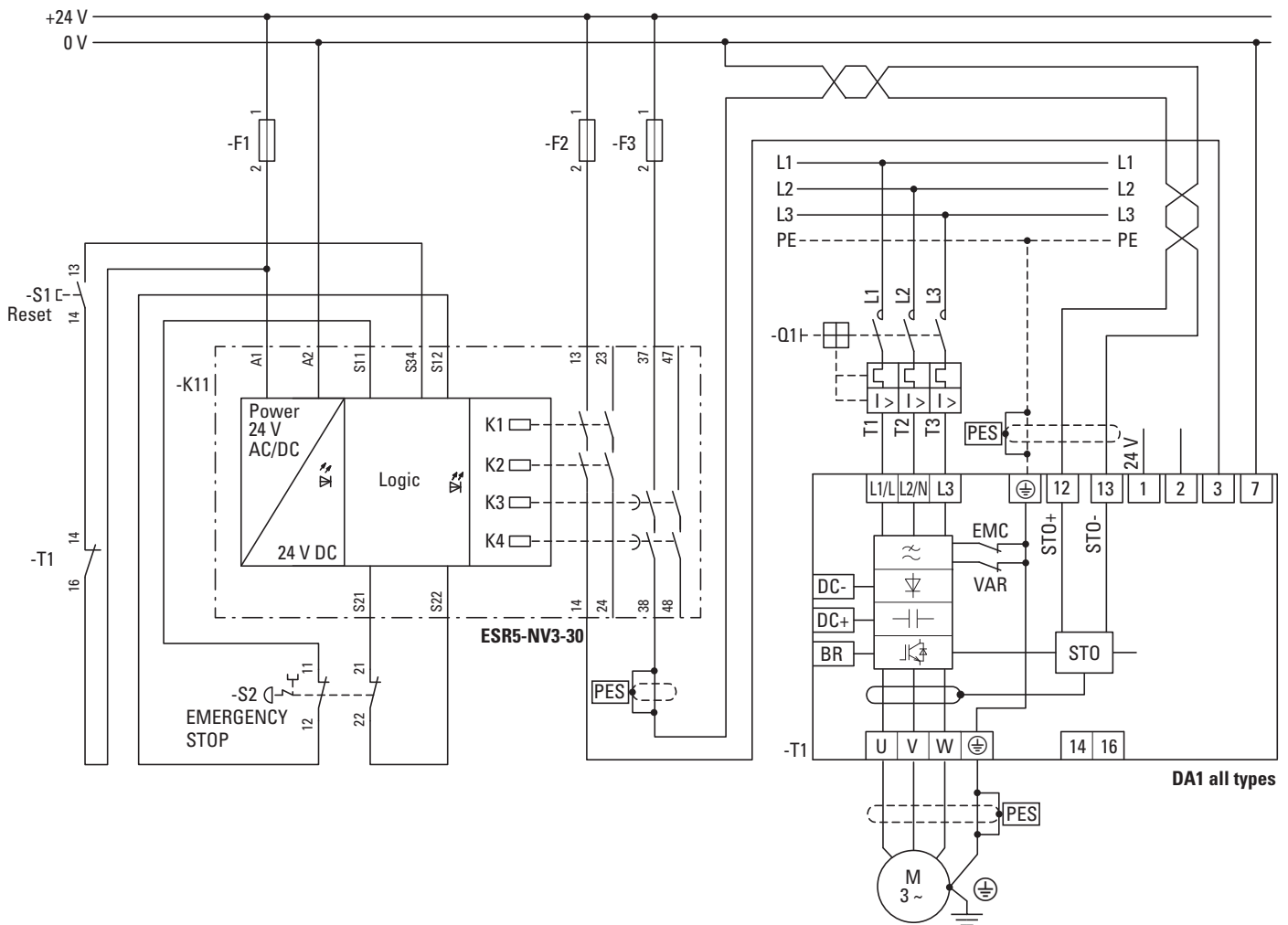

Figure 16: Two-channel emergency stop via STO on a DA1 variable frequency drive

10.2 Two-channel safety door monitoring with dropout delayed contacts and automatic reset (with cross-circuit detection)

- Two-channel safety door monitoring with two position switches and controlled stop
- Cross-circuit detection/ground fault detection
- Automatic reset (A1, S35)
- Feedback of contactor contacts K5 and K6 at S35
- Stop category 1
- Monitoring of external contactors
- Safety level up to PL c (EN ISO 13849-1) and SIL 1 (EN 62061)

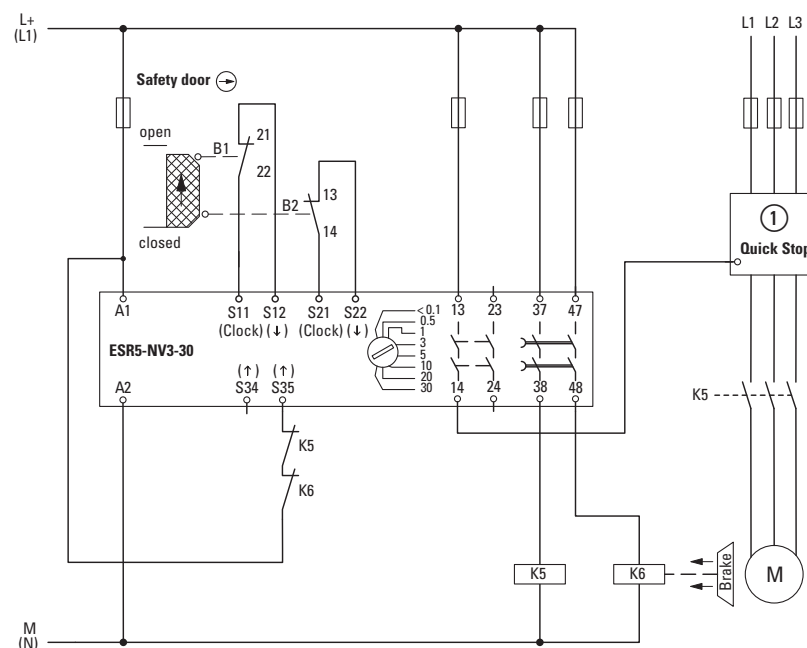

Figure 17: Two-channel safety door monitoring with dropout delayed contacts and automatic reset

① Variable frequency drive

11 Cable lengths

For applications which use clock outputs S11 and S21, the cables may have an overall length of up to 500 m (per channel).

If no clock outputs are used, the maximum cable length can be calculated using the total permissible resistance (500 Ω).

Path	Maximum cable length	Cable resistance
A1 — S34	1 km	500 Ω
A1 — S35		500 Ω
S11 — S12 S21 — S22	500 m without external wiring	500 Ω
S21 — S22	> 500 m wiring with an external resistance of 1 k Ω from S11 to A2 and from S21 to A2.	500 Ω
A1 — S12	1 km	500 Ω
A1 — S22	1 km	500 Ω

The aforementioned values are intended as a guide.

Depending on the wiring and installation of the cable, different lengths can be achieved.

12 Proof test



For high demand applications according to IEC 61508 and EN 62061, the proof test interval corresponds to the switching device's duration of use (see Technical Data section).



Replace the switching device once the period of use has expired.

13 Technical data

Input data	
Nominal input voltage U_N	24 V AC/DC
Input voltage range (factor)	0.85 - 1,1
Typical input current	75 mA DC
Voltage at input/start and feedback circuit	24 V DC
Max. permissible overall conductor resistance (Input and reset circuit at U_N)	500 Ω
Typical response time	150 ms (monitored/manual and auto-start)
Typical release time	20 ms (undelayed contacts)
Delay time range	0,1 s - 30 s \pm 40 % (K3, K4 adjustable)
Recovery time	330 ms (restart)
Operating voltage display	LED, green
Status display	LEDs (K1/K2 und K3(t)/K4(t)), green
Protective circuit	Suppressor diode, 33 V DC
Output data	
Contact type	2 enabling current paths undelayed 2 enabling current paths delayed
Contact material	AgSnO ₂
Minimum switching voltage	15 V AC/DC
Maximum switching voltage	250 V AC/DC
Limiting continuous current	6 A (N/O contact)
Maximum inrush current	6 A
Inrush current, minimum	25 mA
Sq. Total current $(I_{TH})^2 = (I_1)^2 + (I_2)^2 + (I_3)^2 + (I_4)^2$	72 A ² (see derating curve, → Figure 5, page 11)
Interrupting rating (ohmic load) max.	144 W (24 V DC, $\tau = 0$ ms) 288 W (48 V DC, $\tau = 0$ ms) 90 W (110 V DC, $\tau = 0$ ms) 88 W (220 V DC, $\tau = 0$ ms) 1500 VA (250 V AC, $\tau = 0$ ms)
Maximum interrupting rating (inductive load)	48 W (24 V DC, $\tau = 40$ ms) 33 W (48 V DC, $\tau = 40$ ms) 25 W (110 V DC, $\tau = 40$ ms) 23 W (220 V DC, $\tau = 40$ ms)
Switching capacity min.	0.4 W
Mechanical service life	$\sim 10^7$ cycles
Switching capacity (360 cycles/h)	on request
Switching capacity (3600 cycles/h)	3 A (24 V (DC-13)) 3 A (230 V (AC-15))
Output fuse	10 A gL/gG NEOZED (N/O contact)

General data	
Relay type	Electromechanically forcibly guided, dust-proof relay
Nominal operating mode	100 % operating factor
Degree of protection	IP20
Min. degree of protection of inst. location	IP54
Mounting position	any
Air and creepage distances between the power circuits	DIN EN 60947-1
Rated surge voltage / insulation	4 kV (basic insulation)
Dimensions	
W x H x D	22.5 x 99 x 114.5 mm
Connection data	
Conductor cross section, solid	0.2 mm ² - 2.5 mm ²
Conductor cross section, stranded	0.2 mm ² - 2.5 mm ²
Conductor cross section AWG/kcmil	24 - 12
Stripping length	7 mm
Ambient conditions	
Ambient temperature (operation)	-20 °C - 45 °C
Ambient temperature (storage/transport)	-40 °C - 70 °C
Max. permissible relative humidity (operation)	75 %
Max. permissible humidity (storage/transport)	75 %
Certification / Approvals	
Approvals	   <div style="display: inline-block; vertical-align: middle; font-size: 8px; margin-left: 5px;"> Product Safety SIL/PL Capability www.tuv.com ID: 0600000000 </div>
Safety data	
Stop category according to IEC 60204-1	0, 1

13 Technical data

Safety parameters for IEC 61508 - High Demand

SIL	3
PFH _d	1.8 x 10 ⁻⁹ per hour
Diagnostic coverage (DC)	99 %
MTTF _d	63311 years
Demand rate	< 12 months
Proof test intervall	240 months
Duration of use	240 months

The specifications apply assuming the following calculation basis:

B _{10d}	400000 (at 3 A AC-15 DC-13)
Cycles	8760 per year

Safety characteristic data according to EN ISO 13849

Category	4
Performance Level	e
DC _{avg}	99 %
MTTF _d	124.23 years
CCF	passed
Duration of use	240 months

The specifications apply assuming the following calculation basis:

B _{10d}	400000 (at 3 A AC-15 DC-13)
Cycles	8760 per year

14 Glossary

Abbreviation	Description
AC-15, DC-13	Standardized utilization categories and load cases from standard IEC 60947-5-1 that are used to test switching elements, i.e., switching on and off with defined voltages, currents, and loads (electromagnetic loads in particular in this case).
AOPD	Active Opto-electronic Protective Device Device with a sensor function that is implemented with optoelectronic transmission and reception elements that detect when an opaque object in the defined area of protection (or in the way of the light beam axis in the case of light barriers) is blocking the beams generated by the device. AOS is used as an abbreviation synonymous with AOPD in DIN EN 692 ("Machine tools - Mechanical presses - Safety"), DIN EN 693 ("Machine tools - Safety - Hydraulic presses"), and EN 12622 ("Safety of machine tools - Hydraulic press brakes").
AOPDDR	Active Opto-electronic Protective Device responsive to Diffuse Reflection Device with a sensor function that is implemented with optoelectronic transmission and reception elements that detect when an object in the area of protection defined with two dimensions diffusely reflects the beam generated by the device.
ESPE	Electro-sensitive protective equipment
CCF	Common Cause Failure Common cause failure
DC	Diagnostic Coverage Diagnostic coverage
ESR	Electronic safety relay
DF	Duty factor
PL	Performance Level Classification of safety functions used to meet a safety requirement.
HFT	Hardware Fault Tolerance
Cat. / category	Classification of resistance to errors as defined in EN ISO 13849-1
Mission Time T_M	Lifetime
MTTF / $MTTF_d$	Mean Time To Failure Mean time to failure / mean time to dangerous failure
NC	Normally Closed contact, break contact An NC breaks a circuit when it is energized.
NO	Normally-Open contact An NO closes when it is energized.
PFD	Probability Failure on Demand (Low-Demand) Probability of failure relative to the number of requests
PFH_d	Probability of a Dangerous Failure per Hour Probability of dangerous Failures per Hour
SIL	Safety Integrity Level Safety integrity level
SRCF	Safety-Related Control Function Safety-related control function
SRECS	Safety-Related Electrical Control System Safety related electrical, electronic, programmable electronic control system
SRP	Safety-Related Part Safety-related part
SRP/CS	Safety-Related Parts of Control System Safety-related part of a control system

Eaton is an intelligent power management company dedicated to protecting the environment and improving the quality of life for people everywhere. We make products for the data center, utility, industrial, commercial, machine building, residential, aerospace and mobility markets. We are guided by our commitment to do business right, to operate sustainably and to help our customers manage power – today and well into the future.

By capitalizing on the global growth trends of electrification and digitalization, we're helping to solve the world's most urgent power management challenges and building a more sustainable society for people today and generations to come.

For more information, visit [Eaton.com](https://www.eaton.com).