

—
INSTALLATION INSTRUCTION

Switch fuses

OS600-800



Table of contents

03	Installation
04	Labels Clearances per UL98
05	Terminal shrouds OSS_ Terminal clamps OZX_
06	Fuse links Fourth pole OSP_
07	Auxiliary contacts OA_
08	Direct mount handle OSV_
09	Neutral link OS_N3, OXN800S Electronic fuse monitor OFS_
10	Module for aux contacts OEA28_
11	Interlocking OSZT3
12	Fuse indicator DPMM_
13–14	Dimension drawings
15	Warning sheet

Installation

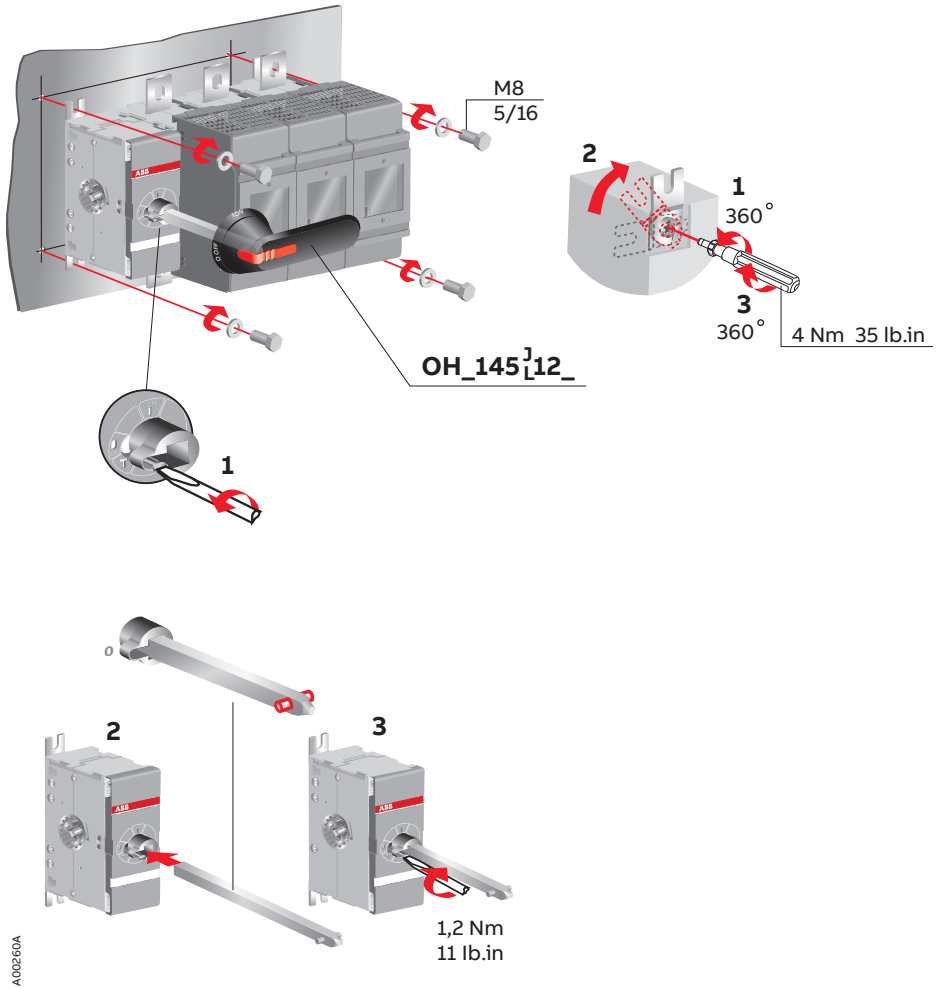

Labels

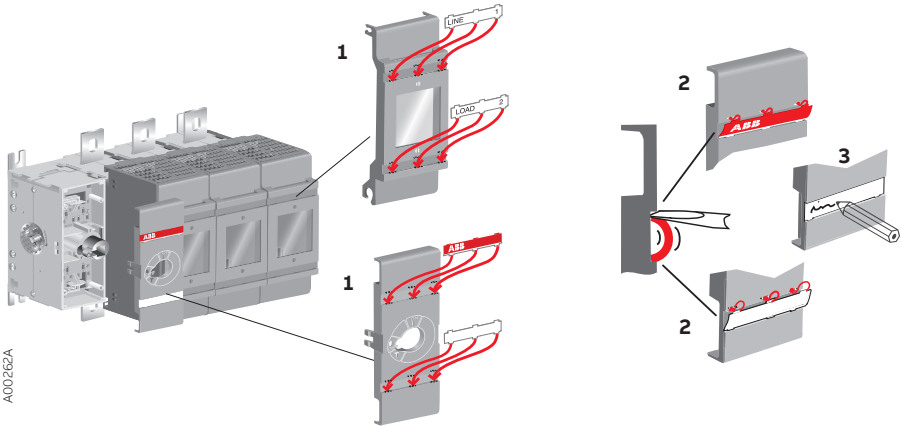

Clearances per UL98

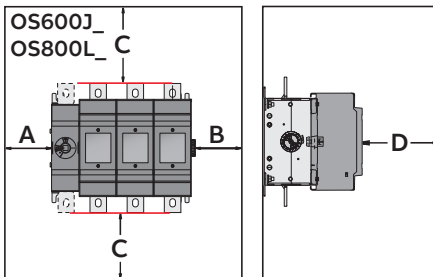

A	B	D
0	13 mm / 0.5 in	13 mm / 0.5 in

Cable size

AWG	C	MCM	C
2	100 mm 4 in	250	200 mm 8 in
1	100 mm 4 in	300	250 mm 10 in
1/0	125 mm 5 in	350	300 mm 12 in
2/0	150 mm 6 in	400	330 mm 13 in
3/0-4/0	175 mm 7 in	500	356 mm 14 in
		600	381 mm 15 in

Minimum enclosure size or equivalent volume

Switch	Height	Width	Depth
OS600J	914 mm 36 in	610 mm 24 in	254 mm 10 in
OS800L	700 mm 27.5 in	900 mm 25.4 in	400 mm 15.7 in

Terminal shrouds

OSS_

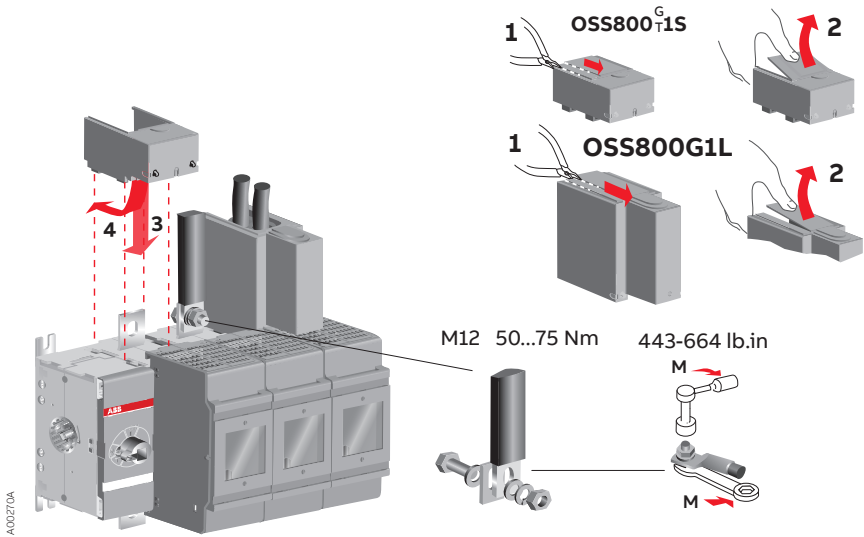

Terminal clamps

OZX_

OS630, OS800

OZXB3
OZXB4
OZXB5
OZXB6
OZXB7L
OZXB8
OZXB9

OS600J, OS800L

OZXA-800
OZXA-806

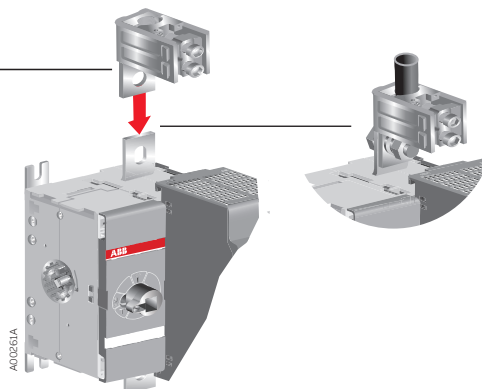

Fuse links

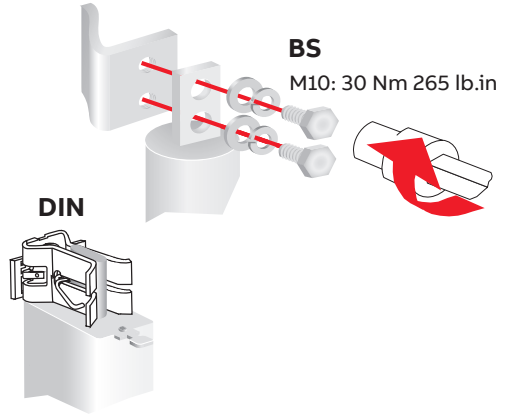
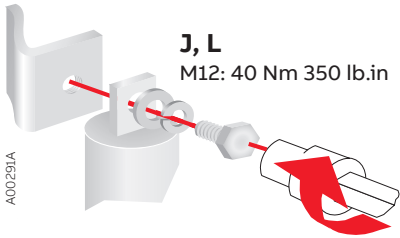

Fourth pole

OSP_

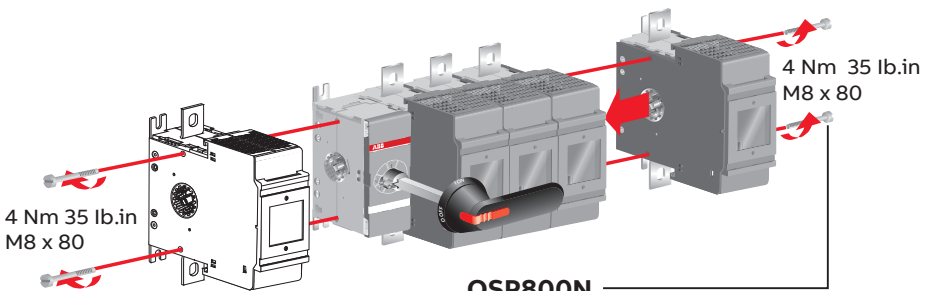

- OSP800N
- OSP800D
- OSP800B
- OSP600J
- OSP800L

Auxiliary contacts

OA_

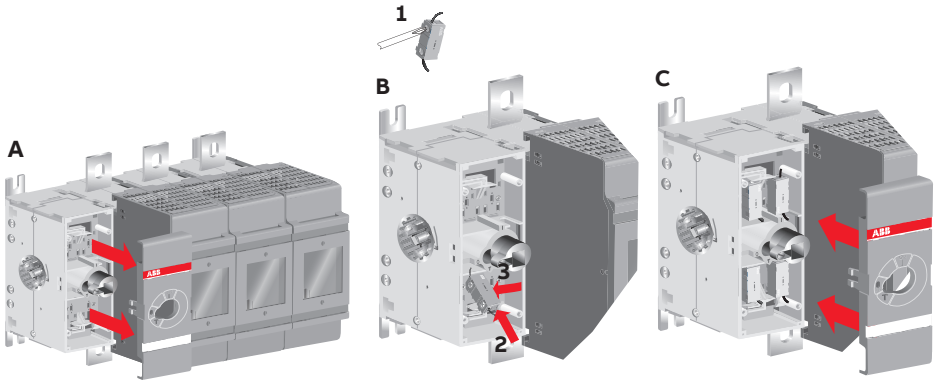

NO: OA1G10
NC: OA3G01

Test contact

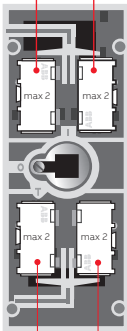

Test indication contact

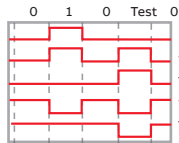

Main contact
 Test contact (NO)
 Test indication contact (NO)
 Test contact (NC)
 Test indication contact (NC)

Remove

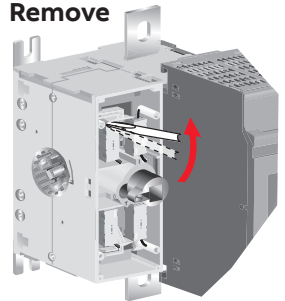

Direct mount handle

OSV_

OSV800DK

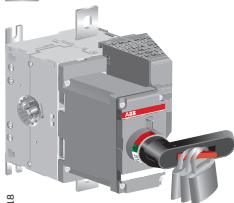
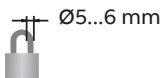
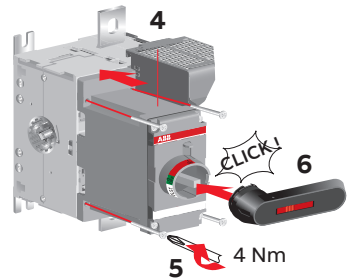
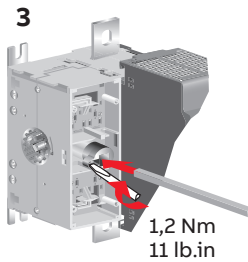
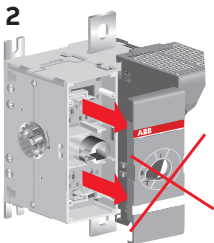
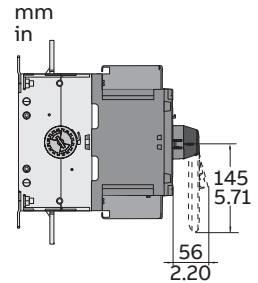
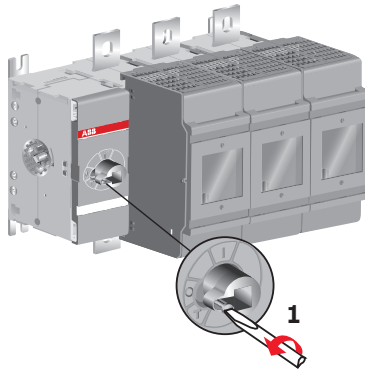
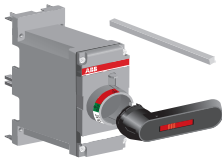

Note: Use protection against direct contact. For example:

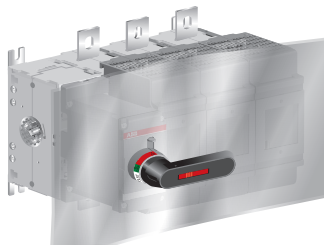

Remove

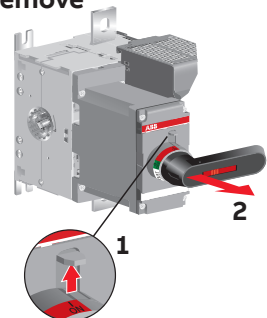

Neutral link

OS_N3, OXN800S

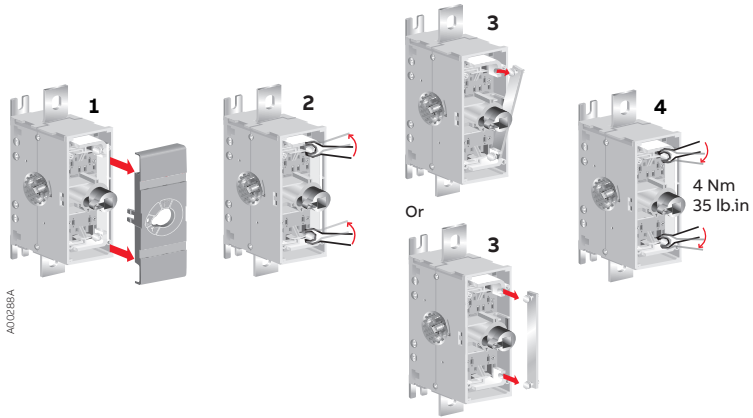

Electronic fuse monitor

OFS_

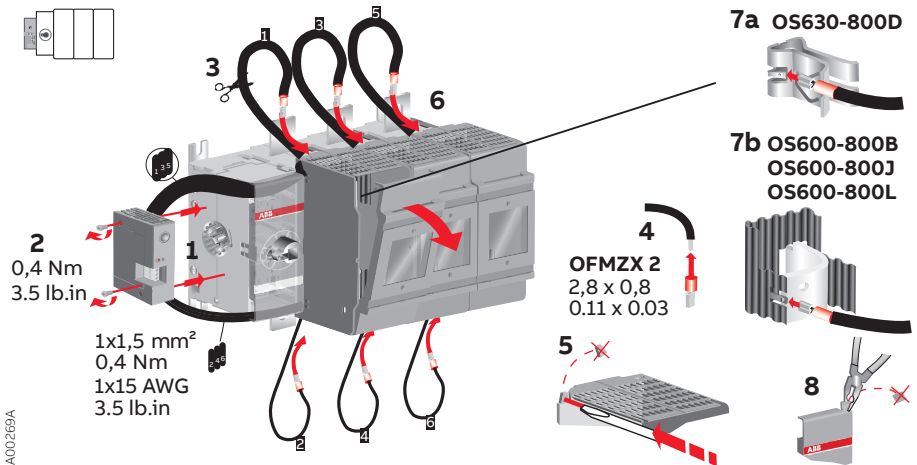

Module for aux contacts

OEA28_

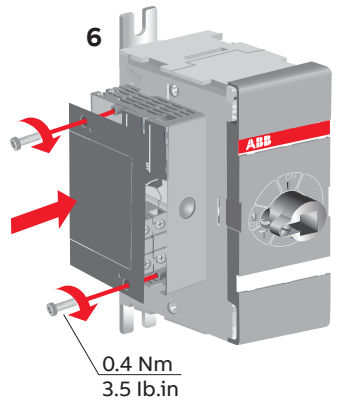
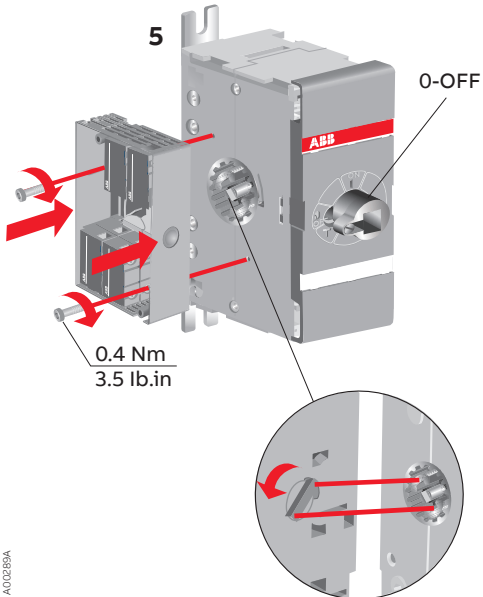
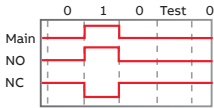
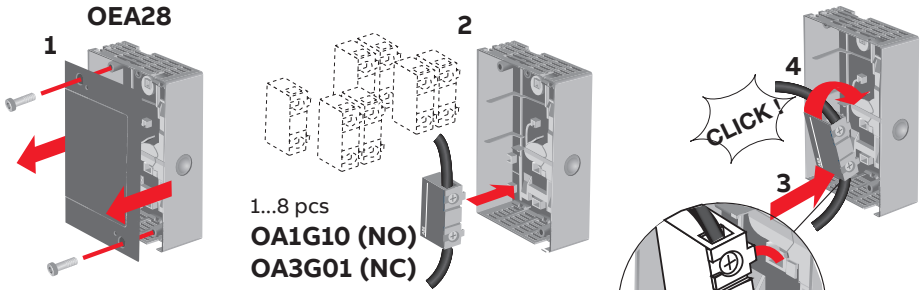

Interlocking

OSZT3

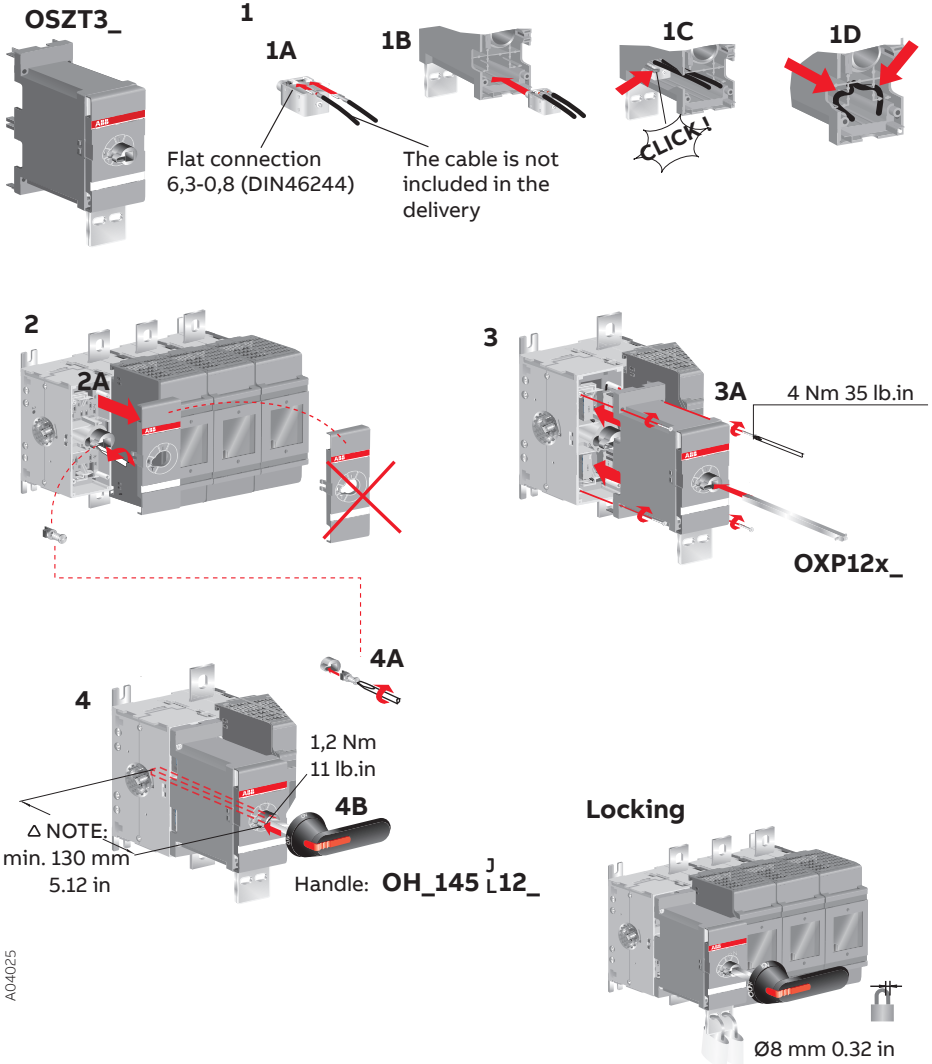

Fuse indicator DPMM_

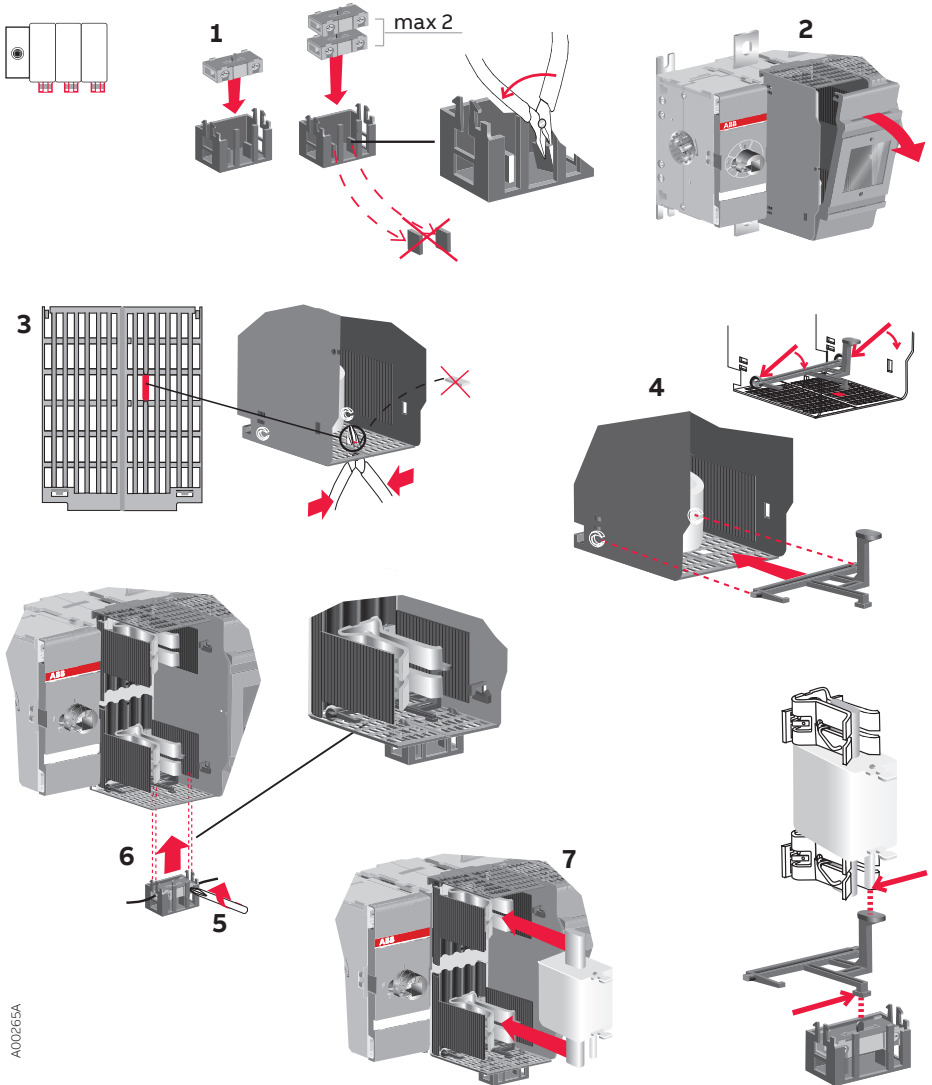

Dimension drawings

OS600-800_11-22

mm
in

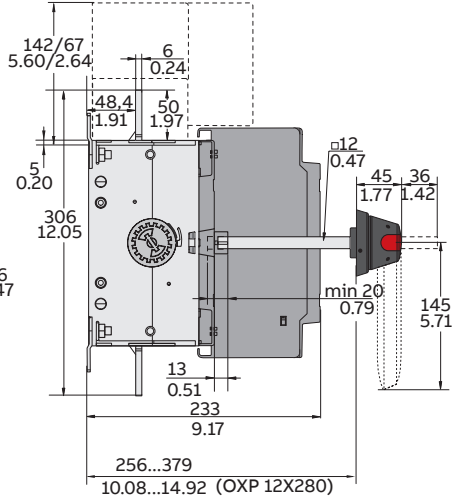
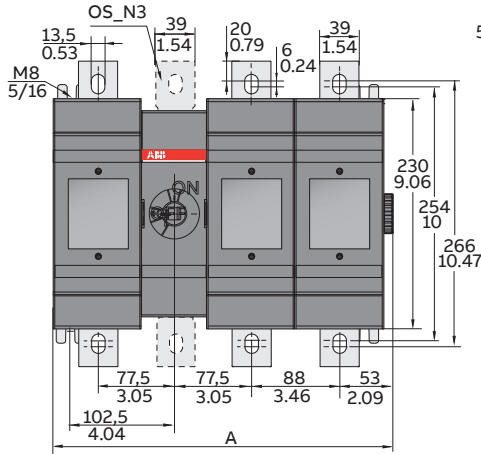

M00100 / OS 600-800_11-22 C

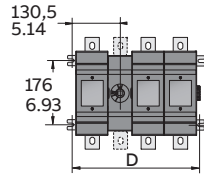
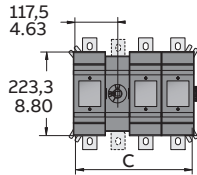
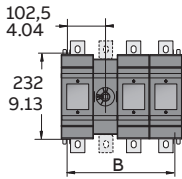

		OS600-800_11-22			
mm					
in	D/B/J/L11	D/B/J/L12	D/B/J/L13	D/B/J/L22	
A	253/9.96	341/13.43	429/16.89	429/16.89	
B	205/8.07	293/11.54	381/15.00	381/15.00	
C	235/9.25	323/12.72	411/16.18	411/16.18	
D	261/10.28	349/13.74	437/17.20	437/17.20	



BG	Внимание! Опасно напрежение! Да се монтира само от лице с електротехническа квалификация.
CN	警告！电压危险！只能由专业电工进行安装。
CZ	Varování! Nebezpečné napětí! Montáž smí provádět výhradně elektrotechnik!
DA	Advarsel! Farlig elektrisk spænding! Installation må kun foretages af personer med elektroteknisk ekspertise.
DE	Warnung! Gefährliche Spannung! Installation nur durch elektrotechnische Fachkraft.
EL	Προειδοποίηση! Υψηλή τάση! Η εγκατάσταση πρέπει να γίνεται μόνο από εξειδικευμένους ηλεκτροτεχνικούς.
EN	Warning! Hazardous voltage! Installation by person with electrotechnical expertise only.
ES	¡Advertencia! ¡Tensión peligrosa! La instalación deberá ser realizada únicamente por electricistas especializados.
ET	Hoiatus! Ohtlik pinge. Paigaldada võib ainult elektrotehnika-alane ekspert.
FI	Varoitus! Vaarallinen jännite! Asennuksen voi tehdä vain sähköalan ammattihenkilö.
FR	Avertissement! Tension électrique dangereuse! Installation uniquement par des personnes qualifiées en électrotechnique.
HR	Upozoreenje! Opasan napon! Postavljati smije samo elektrotehnički stručnjak.
HU	Figyelmeztetés! Veszélyes feszültség! Csak elektrotechnikai tapasztalattal rendelkező szakember helyezheti üzembe.
IE	Rabhadh! Voltas guaiseach! Ba chóir do dhuine ag a bhfuil saineolas leictriteicniúil, agus an té sin amháin, é seo a shuiteáil.
IT	Avvertenza! Tensione pericolosa! Fare installare solo da un elettricista qualificato.
LT	Dėmesio! Pavojinga įtampa! Dirbti leidžiama tik elektrotechniko patirties turintiems asmenims.
LV	Uzmanību! Bīstami - elektrība! Montāžas darbus drīkst veikt tikai personas, kurām ir atbilstošas elektrotehniskās zināšanas.
MT	Twissija! Vultaġġ perikoluż! Għandu jiġi installat biss minn persuna b'kompetenza elettroteknika.
NL	Waarschuwing! Gevaarlijke spanning! Mag alleen geïnstalleerd worden door een deskundige elektrotechnicus.
NO	Advarsel! Farlig spenning! Montering skal kun utføres av kvalifiserte personer med elektrokompetanse.
PL	Ostrzeżenie! Niebezpieczne napięcie! Instalacji może dokonać wyłącznie osoba z fachową wiedzą w dziedzinie elektrotechniki.
PT	Aviso! Tensão perigosa! A instalação só deve ser realizada por um electricista especializado.
RO	Avertizare! Tensiune periculoasă! Instalarea trebuie efectuată numai de către o persoană cu experiență în electrotehnică.
RU	Осторожно! Опасное напряжение! Монтаж должен выполняться только специалистом-электриком.
SE	Varning! Farlig spänning! Installation får endast utföras av en elektriker.
SK	Varovanie! Nebezpečné napätie! Montáž môže vykonávať iba skúsený elektrotechnik.
SL	Opozorilo! Nevarna napetost! Vgradnjo lahko opravi le oseba z elektrotehničnim strokovnim znanjem.



Contact us

ABB Oy

Muottitie 2A, 65320

Vaasa, Finland

www.abb.com/lowvoltage