

# Safety Tool manual for (Original instructions)

## DXX-EXT-SABZ Safety ABZ Encoder Card

## DXX-EXT-FS Functional Safety Card

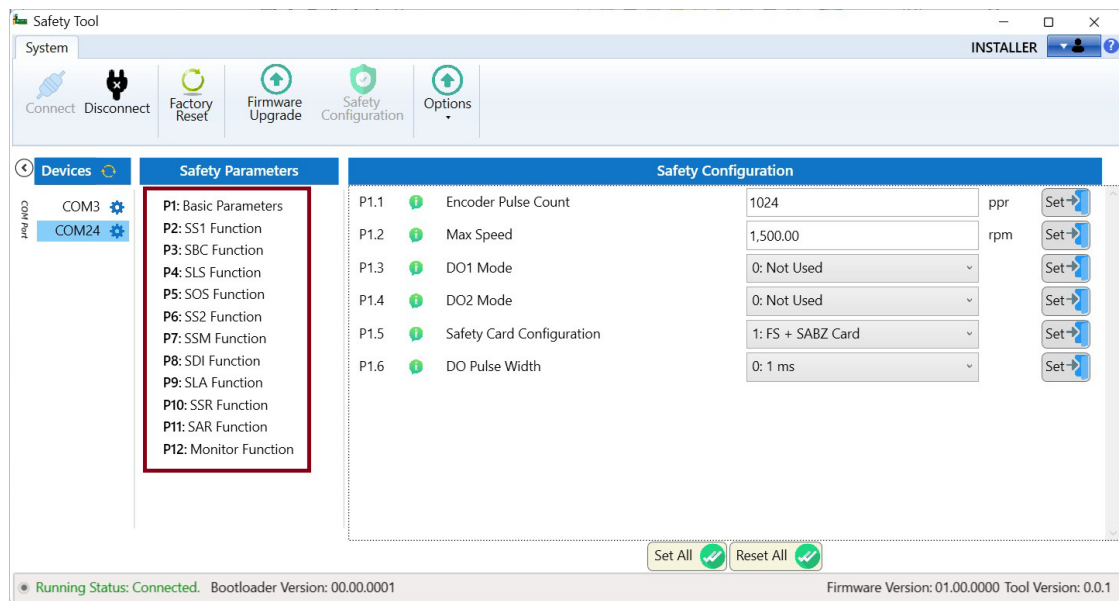

All brand and product names are trademarks or registered trademarks of their respective owners.

### **Service**

For service and support, please contact your local sales organization.

Contact data: [Eaton.com/contacts](https://www.eaton.com/contacts)

### **For customers in US/Canada contact:**

#### **EatonCare Customer Support Center**

Call the EatonCare Support Center if you need assistance with placing an order, stock availability or proof of shipment, expediting an existing order, emergency shipments, product price information, returns other than warranty returns, and information on local distributors or sales offices.

Voice: 877-ETN-CARE (386-2273) (8:00 a.m. – 6:00 p.m. EST)

After-hours emergency: 800-543-7038 (6:00 p.m. – 8:00 a. m. EST)

#### **Drives Technical Resource Center**

Voice: 877-ETN-CARE (386-2273) option 2, option 6

(8:00 a.m. – 5:00 p.m. Central Time U.S. [UTC-6])

Email: [TRCDrives@Eaton.com](mailto:TRCDrives@Eaton.com)

[Eaton.com/drives](https://www.eaton.com/drives)

### **Original Operating Instructions**

The English-language edition of this document is the original operating manual.

#### **Translation of the original operating manual.**

All editions of this document other than those in German language are translations of the original operating manual.

1. 2026 edition, publication date 01/26

See revision protocol in the „About this manual“ chapter

© 2024 by Eaton Industries GmbH, 53105 Bonn

All rights, including those for translation, reserved.

No part of this manual may be reproduced, stored in a retrieval system, or transmitted in any form or by any means, electronic, mechanical, photocopying, micro-filming, recording or otherwise, without the prior written permission of Eaton Industries GmbH, Bonn.

Subject to alteration.



## **Danger!** **Dangerous electrical voltage!**

### **Before commencing the installation**

- Disconnect the power supply of the device.
- Ensure that devices cannot be accidentally retriggered.
- Verify isolation from the supply.
- Ground and short-circuit.
- Cover or enclose neighbouring units that are live.
- Follow the engineering instructions (IL) of the device concerned.
- Only suitably qualified personnel in accordance with EN 50110-1/-2 (VDE 0105 Part 100) may work on this device/system.
- Before installation and before touching the device ensure that you are free of electrostatic charge.
- The functional earth (FE) must be connected to the protective earth (PE) or to the potential equalizing. The system installer is responsible for implementing this connection.
- Connecting cables and signal lines should be installed so that inductive or capacitive interference do not impair the automation functions.
- Install automation devices and related operating elements in such a way that they are well protected against unintentional operation.
- Suitable safety hardware and software measures should be implemented for the I/O connection so that a cable or wire breakage on the signal side does not result in undefined states in the automation device.
- Ensure a reliable electrical isolation of the low voltage for the 24 V supply. Only use power supply units complying with IEC 60364-4-41 or HD 384.4.41 S2 (VDE 0100 part 410).
- Deviations of the mains voltage from the nominal value must not exceed the tolerance limits given in the technical data, otherwise this may cause malfunction and dangerous operation.
- Emergency-Stop devices complying with IEC/EN 60204-1 must be effective in all operating modes of the automation devices. Unlatching the emergency switching off devices must not cause restart.
- Built-in devices for enclosures or cabinets must only be run and operated in an installed state, desk-top devices or portable devices only when the housing is closed.
- Measures should be taken to ensure the proper restart of programs interrupted after a voltage dip or failure. This should not cause dangerous operating states even for a short time. If necessary, emergency switching off devices should be implemented.
- Wherever faults in the automation system may cause damage to persons or property, external measures must be implemented to ensure a safe operating state in the event of a fault or malfunction (for example, by means of separate limit switches, mechanical interlocks, etc.).
- During operation, and depending on their degree of protection, variable frequency drives may have live, uninsulated, moving, and/or rotating parts, as well as hot surfaces.
- The impermissible removal of the required cover, improper installation or incorrect operation of the motor or variable frequency drive can cause the failure of the device and serious injury and/or material damage.
- Comply with all applicable national accident prevention regulations (e.g. BGV A3) when working with energized variable frequency drives.
- The electrical installation must be carried out in accordance with the relevant regulations (e.g. with regard to cable cross sections, fuses, PE).
- All transport, installation, commissioning and maintenance work must only be carried out by trained personnel (observe IEC 60364, HD 384 or DIN VDE 0100 and national accident prevention regulations).
- If applicable, systems in which variable frequency drives are installed must be equipped with additional monitoring and protective devices in accordance with the applicable safety regulations, e.g., the German Equipment and Product Safety Act, accident prevention regulations, etc. Making changes to the variable frequency drives by using the operating software is allowed.
- Keep all covers and doors closed during operation.
- When designing the machine, the user must incorporate mechanisms and measures that limit the consequences of a drive controller malfunction or failure (an increase in motor speed or the motor's sudden stop) so as to prevent hazards to people and property, e.g.:
  - Additional stand-alone devices for monitoring parameters that are relevant to safety (speed, travel, end positions, etc.)
  - Electrical and non-electrical safety devices (interlocks or mechanical locks) for mechanisms that protect the entire system
  - Due to the possibility of there being capacitors that are still holding a charge, do not touch live device parts or terminals immediately after disconnecting the variable frequency drives from the supply voltage. Heed the corresponding labels on the variable frequency drives

# Content

<b>0</b>	<b>About this manual</b> .....	<b>3</b>
0.1	Subject.....	3
0.2	Target audience .....	4
0.3	List of revisions .....	5
0.4	Writing conventions.....	5
0.5	Safety warning concerning property damage.....	5
0.6	Safety warning concerning personal injury hazards.....	6
0.7	Exemption of liability .....	7
0.8	Documents with additional information.....	8
0.9	Abbreviations.....	11
0.10	Units of measurement.....	12
<b>1</b>	<b>Software Safety Tool</b> .....	<b>13</b>
1.1	Checking the delivery of Software .....	13
1.2	General System requirements.....	13
1.2.1	Hardware requirements.....	13
1.2.2	Software requirements.....	13
1.3	Technical Data .....	14
1.4	Supported Safety Functions .....	15
1.5	Functional Safety programming Port.....	18
1.6	Proper Use.....	19
1.7	System Overview .....	21
<b>2</b>	<b>Installation</b> .....	<b>22</b>
2.1	Compatibility overview – software and firmware .....	22
2.2	Installation Procedure .....	23
2.3	Uninstallation Procedure.....	29
2.4	Software Update Procedure .....	30
<b>3</b>	<b>General information on safety functions</b> .....	<b>31</b>
3.1	STO.....	32
3.2	Other Safety Functions.....	33
3.3	Safe state .....	33
3.4	Response Time.....	33
3.5	Safety Related Parameter.....	34

<b>4</b>	<b>Commissioning</b> .....	<b>35</b>
4.1	User Access Levels .....	35
4.1.1	Access to User Levels .....	35
4.1.2	Assigning Password .....	36
4.2	Serial Port Settings .....	38
4.3	Connecting and Disconnecting to the FS or S-ABZ cards .....	40
4.4	Factory reset.....	42
4.5	Information Panel .....	43
4.6	Safety Configuration and Firmware Upgrade .....	44
4.7	Parameter Structure .....	45
4.8	Parameter Settings .....	46
4.9	Firmware Upgrade and Downgrade .....	51
4.10	User Interface for Update.....	52
4.11	Using the Safety tool .....	53
4.11.1	Parameter access .....	53
4.11.2	Set Factory Settings .....	57
4.11.3	Firmware Upgrade .....	58
<b>5</b>	<b>List of Parameters</b> .....	<b>62</b>

## 0 About this manual

### 0.1 Subject

## 0 About this manual

### 0.1 Subject

This manual is the original operating manual and describes functionality of Safety Tool for DX1 variable frequency drives.

This document provides information about the safety software and the supported functions. The manual explains the process of installing the Safety Tool and details for configuration and commissioning. Each chapter delves into the description of the supported safety functions.

The purpose of this manual is to provide users with information regarding installation, configuration, and execution of Safety Tool software. To ensure correct usage of the software tool, follow the instructions, guidelines, warnings, and caution presented in this manual. The Safety Tool manual is specific for FS and S-ABZ cards.

For drive-specific technical, configuration, and installation details, please refer to the Drive Application Manual, MN040069.

For the FS and S-ABZ card specific technical, configuration, and installation details, please refer to the Functional Safety Card and Safety Encoder Card manual MN040070.

## 0.2 Target audience

The reader is expected to be familiar with FS card, S-ABZ, Safety Tool and the international standards ENISO13849-1 Version 2015, ENISO13849-1 version 2023, and IEC 62061 2021. Also basic knowledge of Microsoft Windows operating system is needed.

→ Knowledge and correct application of the relevant standards and directives, in particular IEC 62061 2021 are requirements for using this tool. The tool is aimed to help the user with parameter configuration and firmware upgrade/downgrade of FS and S-ABZ cards. Therefore this manual is intended for engineers, electricians, and automation technicians.

A thorough knowledge of the Power Drive System and the programming of a Safety PLC is required. Additionally, knowledge of handling the DX1 variable frequency drive is required. Please read this manual carefully before running the Safety Tool of DX1. We assume that you have a good knowledge of engineering fundamentals, and that you are familiar with handling electrical systems and machines, as well as with reading technical drawings. The manual is specifically designed for qualified individuals responsible for designing, planning, installing, and commissioning safety applications. Prior to commencing work on the safety application, it is essential to thoroughly read this manual. Proficiency in safety technology, electricity, wiring, electrical components, and electrical circuit symbols is imperative. Authorization to work on and with this product is granted exclusively to adequately trained individuals who possess a comprehensive understanding of the contents of this manual and all other pertinent product documentation. Furthermore, these individuals must have practiced safety training to identify and mitigate associated hazards. Moreover, these individuals should have attained sufficient technical training, knowledge, and experience to anticipate and recognize potential hazards. They must be adept at foreseeing and identifying potential risks stemming from the use of the product, adjustments to settings, and the mechanical, electrical, and electronic components of the overall system in which the product is integrated. It is imperative that all individuals involved in working with the product are well-acquainted with all relevant documentation.

Extensive knowledge of safety standards such as EN ISO 12100, 61800-5-2, EN ISO 13849-1, EN ISO 13849-2, IEC 61508, IEC 60204-1 and IEC 62061 is mandatory.



### CAUTION

Installation requires a qualified electrician

## 0 About this manual

### 0.3 List of revisions

### 0.3 List of revisions

The following significant amendments have been introduced since previous issues:

Publication date	Page	Keyword	new	modified	deleted
12/24		First edition	✓	–	–

### 0.4 Writing conventions

Symbols with the following meaning are used in this manual:

- ▶ Indicates instructions to be followed.

### 0.5 Safety warning concerning property damage

#### **NOTICE**

Indicates a potentially hazardous situation that may result in property damage.

Ensure that the service life of each individual component employed in your application is sufficient for the intended overall service life of your application.

After an emergency stop, the shutdown must align with Stop Category 0 or 1 (STO or SS1) according to EN 60204-1. To prevent the risk of injury resulting from unintended movements of the motor, automatic restart following an emergency stop must be avoided.

The deactivation of specific safety functions may, depending on the risk analysis, allow for automatic restart, except in the case of resetting an emergency stop. For instance, the closure of a protective door may enable an automatic start. If there is a risk of potential damage caused by moving loads, such as the potential for loads to slip or fall, it is advisable to operate the drive in closed-loop mode. Conduct comprehensive commissioning tests to guarantee that, under all conceivable error scenarios, the load can be safely brought to a halt.

It is imperative to ensure that, in the mentioned scenarios, no automatic restart occurs. Conduct thorough commissioning tests for all potential error situations to verify the effectiveness of safety-related functions and monitoring mechanisms implemented. This encompasses, but is not limited to, speed monitoring using encoders, short-circuit monitoring for all connected equipment, and the proper functioning of brakes and guards.

## 0.6 Safety warning concerning personal injury hazards



### CAUTION

Warns of hazardous situations that may cause slight injury.



### WARNING

Warns of hazardous situations that could result in serious injury or death.



### DANGER

Warns of hazardous situations that result in serious injury or death.



Indicates useful tips.

Risk of injury or fatality exists when safety instructions and residual risks are disregarded. Failing to comply with the safety instructions and residual risks specified in the associated hardware documentation can lead to accidents causing severe injuries or death. It is crucial to rigorously adhere to the safety instructions provided in the hardware documentation and to consider residual risks during the risk assessment.

Motors can generate voltage during shaft rotation. Before undertaking any work on the drive system, secure the motor shaft to prevent rotation. Avoid contact with unshielded components or terminals with active voltage. Disconnect all power sources, including external control power, and be aware that the circuit breaker or main switch may not de-energize all circuits.

Adhere to all accident prevention regulations and local safety guidelines. Each product implementation must undergo thorough individual testing for proper operation before being put into service. Do not operate the product with unknown or inappropriate settings or data.

The application comprises various interconnected mechanical, electrical, and electronic components, with the drive being just one component. The drive alone is neither intended nor capable of providing the entire functionality to meet all safety-related requirements applicable to the application.

## 0.7 Exemption of liability

We have provided all the information in this manual to the best of our knowledge and belief and in accordance with the latest state of the art safety technology. This statement emphasizes the commitment to delivering accurate and up-to-date information, aligning with industry standards and practices. However, this does not exclude the possibility of inaccuracies so that we cannot accept any liability for the accuracy and completeness of the information.

Here, the acknowledgment of the potential for inaccuracies reinforces transparency. It also clarifies that the company cannot be held responsible for any discrepancies or omissions.

In particular, this information does not guarantee any particular properties. This phrase underscores that the information provided serves as a guide and reference but does not imply a warranty for specific features or outcomes. The devices described must only be installed and operated in accordance with the content of documentation (this manual and the installation instructions) provided with the device. This highlights the importance of strictly adhering to the provided documentation to ensure proper installation and operation of the devices.

Installation, commissioning, operation, maintenance, and refitting of the devices must only be carried out by qualified persons. The emphasis on qualified personnel underlines the need for expertise in handling various aspects of the devices' lifecycle, promoting safety and optimal performance. The devices must only be used in the areas recommended and only in conjunction with third-party devices and components that have been approved by us. This emphasizes the importance of following specified guidelines and using approved components to maintain the integrity of the system.

Only use in a technically faultless condition is permitted. Fault-free and safe operation of the system requires proper transport, storage, installation, as well as careful operation and maintenance. If the above safety instructions are not observed, particularly with regard to commissioning and maintenance of the devices by insufficiently qualified personnel and/or in the event of improper use of the devices, any hazards caused by the devices cannot be excluded. This warning underscores the potential risks associated with non-compliance, particularly when tasks are performed by inadequately qualified personnel or when devices are used improperly.

We cannot accept any liability for any resulting injury or damage.

## 0.8 Documents with additional information

Prior to installation and usage of the Safety tool, users must contact local safety management and network administrators to ensure proper procedures and protocols are followed in accordance with the end users' standards in safety, network security, or any other related fields.

Any violation of these policies is strictly on the user and in no way voices the procedures laid out herein as these are guidelines of how to use the tool itself.



More information on the devices described here can be found online at:

[Eaton.com/powerxl](http://Eaton.com/powerxl)

as well as

[Eaton.com/documentation](http://Eaton.com/documentation)

In the Search field, enter the document name (for example "MN040074" for this manual).

Additional information can be found in the following documents:

Type	Description	Document
Manual	PowerXL™ Functional Safety Cards for DX1 variable frequency drives DXX-EXT-SABZ, DX1 S-ABZ card DXX-EXT-FS, FS card	MN040070
Manual	Safety Manual	PU05907001Z
Product notifications	Safety-relevant characteristic values for Eaton components	MZ027051



### CAUTION

This manual is aligned with the following standards. It is advisable to acquaint yourself with these standards before proceeding with the implementation of the safety system:

EN/IEC 61800-5-2: Adjustable speed electrical power drive systems - Part 5-2: Safety requirements - Functional. (Includes safety function definitions.)

EN ISO 13849-1: Safety of machinery - Safety-related parts of control systems - Part 1: General principles for design

EN/IEC 62061: Safety of machinery - Functional safety of safety-related electrical, electronic and programmable electronic control systems

EN 60204-1: Safety of machinery - Electrical equipment of machines - Part 1: General requirements.



**WARNING**

The housing, as well as other safety-relevant parts, has been left out in some of the figures in this manual in order to make the figures easier to understand. However, it is important to note that the components described in this manual must always be operated with their housing installed properly, as well as with all required safety-relevant parts.



**DANGER**

When active components are controlled, such as motors or pressurized cylinders, plants may become damaged or persons endangered, if FS or S-ABZ card is incorrectly connected, or incorrectly configured.



**DANGER**

The power up of the PowerXL DX1 Drive must not cause any hazards arising from activated devices, such as unexpected motor startups or power ups.



After the initial commissioning of FS or S-ABZ card with Safety tool and also after any subsequent modification of application parameters or configuration, the security of the entire system must be confirmed through an inspection following the System Security Inspection Plan and by verifying the correct functioning of the security application.

**WARNING**

During phases of the product lifespan in which the FS or S-ABZ card option may not provide protection, such as during commissioning, equipment maintenance, troubleshooting, and decommissioning, user safety must be ensured through alternative means.



**WARNING**

Operate the Safety Tool for the FS card and S-ABZ card in compliance with the guidelines provided in the user manual. Eaton is not responsible for damages resulting from the misuse of the module. The Safety Tool is not designed to protect a machine against intentional misuse.



All the specifications in this manual refer to the hardware and software versions documented in it. Follow the installation instructions in the relevant instruction leaflets.

### **Diagnose of the FS and S-ABZ card**

By using Safety tool, it is possible to diagnose and monitor the FS Card and Encoder Card.

During operation, the FS and S-ABZ cards conducts a comprehensive automatic self-diagnosis of its internal components as well as the communication links between the DXG-FS and the frequency inverter. The FS and S-ABZ cards switch to the fail-safe mode upon detecting a malfunction.

### **Feedback Signal**

The Feedback signal can be read by Safety Tool.

In order for the FS or S-ABZ card to operate its safety functions effectively, it depends on receiving feedback related to the motor speed. This critical information is obtained through the speed measurement provided by a safety pulse generator. It is crucial to recognize that the accuracy of the safety functions might be influenced by the inherent imprecision in calculating the safe speed based on this feedback.

The performance of safety functions may demonstrate slight variations based on the feedback received for the motor speed. This could result in subtle differences in the activation or deactivation of notifications, highlighting the impact of the imprecise calculation of the secure speed.

Moreover, the selection of the feedback method significantly shapes the configuration of the safety functions.

### **Configuration**

FS and S-ABZ cards can be configured by authorized individuals using the Safety Tool.

**0.9 Abbreviations**

The following abbreviations are used in this manual.

AWG	American wire gauge
Cat.	Classification of the safety-related parts of a control system.
CCF	Common cause failure
DC	Diagnose coverage
DCavg	Average diagnostic coverage
DI	Digital Input
DO	Digital Output
DS	Default setting
E-stop	Emergency stop
EN	European Norm
EMC	Electromagnetic compatibility
FE	Functional earth
FS	Frame size
FS-Card	Functional Safety Card
FST	Functional Safety Tool
FWD	Forward run (clockwise rotating field)
FUT	Firmware Upgrade Tool
GND	Ground (0-V-potential)
HFT	Hardware Fault Tolerance
IGBT	Insulated Gate Bipolar Transistor
I/O	PLC Input Output
ISO	International Organization for Standardization
LED	Light emitting diode (LED)
MCU	Motor Control Unit
MTTFd	Mean time to dangerous failure
MTTR	Main Time to repair
OLED	Organic light emitting diode
PC	Personal computer
PDS	Power Drive System (drive system)
PF Davg	Average probability of (random hardware) failure on demand
PFH	Probability of a dangerous random hardware Failure per Hour
PL	Performance Level
PLC	Programmable Logic Controller
PE	Protective Earth
PES	EMC connection to PE for screened lines
PNU	Parameter Number
RAM	Random Access Memory
REV	Reverse Run (anticlockwise rotation field active)

SAR	Safe acceleration range
SBC	Safe brake control
SCCR	Short Circuit Current Rating
SDI	Safe Direction
SFF	Safe Failure Fraction
SIL	Safety Integrated Level
SLA	Safely-Limited Acceleration
SLS	Safely-limited speed
SMS	Safe maximum speed
SOS	Safe Operating Stop
SS1	Safe stop 1
SS1-r	Safe stop 1 ramp monitored
SS1-t	Safe stop 1 time controlled
SS2	Safe Stop 2
SSM	Safe Speed Monitor
SSR	Safe Speed Range
STO	Safe torque off
TM	Mission time
UI	User Interface
UL	Underwriters Laboratories

## 0.10 Units of measurement

Every physical dimension included in this manual uses international metric system units, otherwise known as SI (Système International d'Unités) units. For the purpose of the equipment's UL certification, some of these dimensions are accompanied by their equivalents in imperial units.

Table 1: Unit conversion examples

Designation	US-American Designation	Anglo American value	SI value	Conversion value
Length	inch	1 in (")	25.4 mm	0.0394
Output	horsepower	1 HP = 1.014 PS	0.7457 kW	1.341
Torque	pound-force inches	1 lbf in	0.113 Nm	8.851
Temperature	Fahrenheit	1 °F (T <sub>F</sub> )	-17.222°C (T <sub>C</sub> )	T <sub>F</sub> = T <sub>C</sub> × 9/5 + 32
Speed	revolutions per minute	1 rpm	1 min <sup>-1</sup>	1
Weight	pound	1 lb	0.4536 kg	2.205
Flow rate	cubic feed per minute	1 cfm	1.698 m <sup>3</sup> /min	0.5889

## 1 Software Safety Tool

### 1.1 Checking the delivery of Software

## 1 Software Safety Tool

### 1.1 Checking the delivery of Software

Before opening the software package, please check the Software to make sure that you downloaded correct version.

The FS card and S-ABZ cards have their own firmware versions.

The compatible software and firmware must be aligned with the Eaton technical resources.

### 1.2 General System requirements

#### 1.2.1 Hardware requirements

Prior to installing the software following minimum hardware system must be provided by the PC:

- 32-bit or 64-bit compatible PC
- 1 GB RAM
- Maximum 50 MB of hard disk space

#### 1.2.2 Software requirements

Prior to installing the software following minimum software system must be provided by the PC:

- Operating system Windows 8 and higher
- Microsoft .NET Framework 4.0.
- Microsoft Office 2007 or above.

## 1.3 Technical Data

Safety Tool (PC software) is used to configure safety parameters and upgrade firmware of FS and S-ABZ cards, this tool is developed acc. to EN ISO 13849-1 requirements.

The safety functions are compatible according to IEC 61800-5-2 Ed.2

Adjustable speed electrical power drive systems - Part 5-2: Safety

requirements - Functional. IEC 61800-5-2, as a product standard, sets out safety-related considerations of Power Drive System Safety Related PDS (SR)s in terms of the framework of the IEC 61508 Ed.2 series of standards.

Compliance with the IEC 61800-5-2 standard, for the safety functions described below, facilitates incorporation of a PDS (SR) (Power Drive System suitable for use in safety-related applications) into a safety-related control system using the principles of IEC 61508, or IEC 13849-1, as well as IEC 62061 for process systems and machinery.

EN 61800-5-1:2007+A1:2017+A11:2021 Adjustable speed electrical power drive systems – Part 5-1: Safety requirements – Electrical, thermal and energy

EN 61800-5-1:2023 Adjustable speed electrical power drive systems Part 5-1: Safety requirements – Electrical, thermal and energy

EN 61800-5-2:2007 Adjustable Speed Electrical Power Drive Systems Part 5-2: Safety Requirements – Functional

EN 61800-5-2:2017 Adjustable Speed Electrical Power Drive Systems Part 5-2: Safety Requirements – Functional

EN ISO 13849-1:2015 Safety of Machinery – Safety-related parts of control systems – Part 1: General Principles for Design

EN ISO 13849-1:2023 Safety of Machinery – Safety-related parts of control systems – Part 1: General Principles for Design

EN 61508 Parts 1-7:2010 Functional Safety of Electrical/Electronic/Programmable Electronic Safety-related systems

EN IEC 62061:2021 Safety of machinery – Functional safety of safety related control systems

EN IEC 61800-3:2018 Adjustable speed electrical power drive systems – Part 3: EMC requirements and specific test methods

EN 60204-1:2018 Safety of machinery – Electrical equipment of machines – Part 1: General requirements

# 1 Software Safety Tool

## 1.4 Supported Safety Functions

### 1.4 Supported Safety Functions

The table below is not for the evaluation of the PL of the PDS!

Supported Safety Functions as Defined by Standard IEC 61508, IEC 62061 and ISO 13849-1:

Safety Function	Safety Level	Response Time	Diagnostic test interval	Proof test internal / Mission Time	DC, HFT, SFF	MTTFd	Operation Mode	Safety State	cat
<b>Stopping functions</b>									
STO (Safe Torque Off)	SIL 3, PL e, Cat. 4	The response time from STO terminal input to removal of motor torque $\leq 35$ ms	The period of internal diagnostic pulse = 100 ms for STO channel 1, and 66.7 ms for STO channel 2. The internal diagnostic pulse width = 0.1 ms.	20 Years	1oo1 part: HFT = 0, DC = 99 %, SFF: > 99 % 1oo2 part: HFT = 1, DC = 99 %, SFF: > 99 %	30 Years	High Demand	shutdown of motor torque	0
SS1 (Safe Stop 1 (safe stop with following STO))	SIL 3, PL e, Cat. 3	$\leq 40$ ms.	The diagnose test interval $\leq 400$ ms. The period of internal diagnostic pulse = 100 ms for both channel 1 and channel 2. The internal diagnostic pulse width = 1 ms for DI circuit and 0.1 ms for DO circuit.	20 Years	HFT = 0, DC = 99 %, SFF > 99 %; HFT = 1, DC = 90 %, SFF > 90 %.	30 Years	High Demand	shutdown of motor torque	1
SS2 (Safe Stop 2 (safe stop with following SOS))	SIL 2, PL c, Cat. 2	$\leq 40$ ms.	The diagnose test interval $\leq 400$ ms. The period of internal diagnostic pulse = 100 ms for both channel 1 and channel 2. The internal diagnostic pulse width = 1 ms for DI circuit and 0.1 ms for DO circuit.	20 Years	HFT = 0, DC = 90 %, SFF > 90 % HFT = 1, DC = 60 %, SFF > 60 %.	30 Years	High Demand	shutdown of motor torque	2

# 1 Software Safety Tool

## 1.4 Supported Safety Functions

Safety Function	Safety Level	Response Time	Diagnostic test interval	Proof test internal / Mission Time	DC, HFT, SFF	MTTFd	Operation Mode	Safety State	cat
<b>Monitoring functions</b>									
SOS (Safe operating stop (actively hold the motor in stop position))	SIL 2, PL c, Cat. 2	≤ 40 ms.	The diagnose test interval ≤ 400 ms. The period of internal diagnostic pulse = 100 ms for both channel 1 and channel 2. The internal diagnostic pulse width = 1 ms for DI circuit and 0.1ms for DO circuit.	20 Years	HFT = 0, DC = 90 %, SFF > 90 % HFT = 1, DC = 60 %, SFF > 60 %.	30 Years	High Demand	shutdown of motor torque	-
SLA (Safe limited acceleration)	SIL 3, PL e, Cat. 3	≤ 40 ms.	The diagnose test interval ≤ 400 ms. The period of internal diagnostic pulse = 100 ms for both channel 1 and channel 2. The internal diagnostic pulse width = 1 ms for DI circuit and 0.1 ms for DO circuit.	20 Years	HFT = 0, DC = 90 %, SFF > 90 % HFT = 1, DC = 60 %, SFF > 60 %.	30 Years	High Demand	shutdown of motor torque	-
SAR (Safe acceleration range)	SIL 3, PL e, Cat. 3	≤ 40 ms.	The diagnose test interval ≤ 400 ms. The period of internal diagnostic pulse = 100 ms for both channel 1 and channel 2. The internal diagnostic pulse width = 1 ms for DI circuit and 0.1 ms for DO circuit.	20 Years	HFT = 0, DC = 99 %, SFF > 99 %; HFT = 1, DC = 90 %, SFF > 90 %.	30 Years	High Demand	shutdown of motor torque	-
SLS (Safe limited speed)	SIL 3, PL e, Cat. 3	≤ 40 ms.	The diagnose test interval ≤ 400 ms. The period of internal diagnostic pulse = 100 ms for both channel 1 and channel 2. The internal diagnostic pulse width = 1 ms for DI circuit and 0.1ms for DO circuit.	20 Years	HFT = 0, DC = 99 %, SFF > 99 %; HFT = 1, DC = 90 %, SFF > 90 %.	30 Years	High Demand	shutdown of motor torque	-
SSR (Safe speed range)	SIL 3, PL e, Cat. 3	≤ 40 ms.	The diagnose test interval ≤ 400 ms. The period of internal diagnostic pulse = 100 ms for both channel 1 and channel 2. The internal diagnostic pulse width = 1 ms for DI circuit and 0.1 ms for DO circuit.	20 Years	HFT = 0, DC = 99 %, SFF > 99 %; HFT = 1, DC = 90 %, SFF > 90 %.	36 Years	High Demand	shutdown of motor torque	-
SSM (Safe Speed Monitor)	SIL 3, PL e, Cat. 3	≤ 40 ms.	The diagnose test interval ≤ 400 ms. The period of internal diagnostic pulse = 100 ms for both channel 1 and channel 2. The internal diagnostic pulse width = 1 ms for DI circuit and 0.1 ms for DO circuit.	20 Years	HFT = 0, DC = 99 %, SFF > 99 %; HFT = 1, DC = 90 %, SFF > 90 %.	30 Years	High Demand	output low level of DO.	-

# 1 Software Safety Tool

## 1.4 Supported Safety Functions

Safety Function	Safety Level	Response Time	Diagnostic test interval	Proof test internal / Mission Time	DC, HFT, SFF	MTTFd	Operation Mode	Safety State	cat
SDI (Safe Direction)	SIL 2, PL c, Cat. 2	≤ 40 ms.	The diagnose test interval ≤ 400 ms The period of internal diagnostic pulse = 100 ms for both channel 1 and channel 2. The internal diagnostic pulse width = 1 ms for DI circuit and 0.1 ms for DO circuit.	20 Years	HFT = 0, DC = 90 %, SFF > 90 % HFT = 1, DC = 60 %, SFF > 60 %.	30 Years	High Demand	shutdown of motor torque	-

### Output functions

SBC (Safe Brake control)	SIL 3, PL e, Cat. 3	≤ 40 ms.	The diagnose test interval ≤ 400 ms The period of internal diagnostic pulse = 100 ms for both channel 1 and channel 2. The internal diagnostic pulse width = 1 ms for DI circuit and 0.1 ms for DO circuit.	20 Years	HFT = 0, DC = 99 %, SFF > 99 %; HFT = 1, DC = 90 %, SFF > 90 %.	38 Years	High Demand	output low level of DO.	
--------------------------	---------------------	----------	--	----------	--	----------	-------------	-------------------------	--

### 1.5 Functional Safety programming Port

The following figure shows the interface of the main board. Use RS485 serial port for the programming.  
 A serial cable DXX-CBL-PCCABLE article nr. 730-32037-00P of Eaton is required!

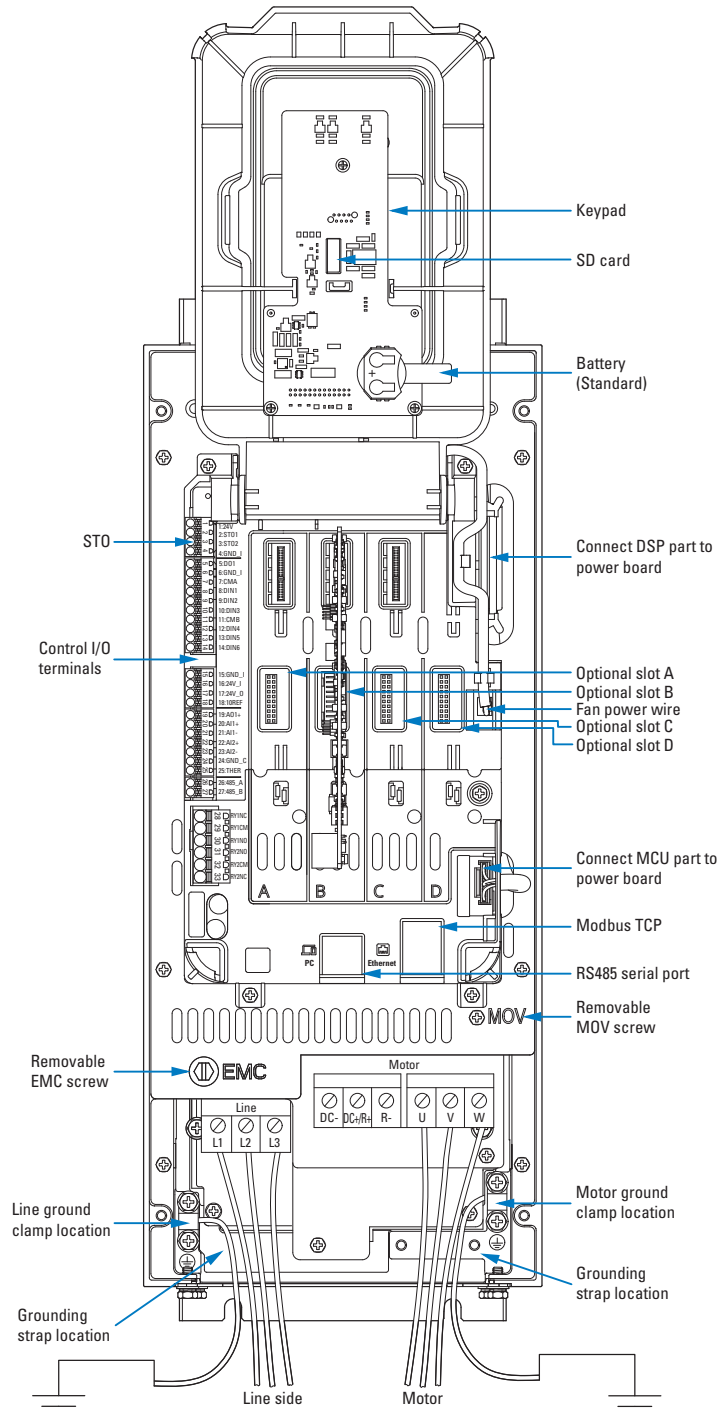

Figure 1: Interface of the main board

# 1 Software Safety Tool

## 1.6 Proper Use

### 1.6 Proper Use

The purpose of this manual is to provide users with information regarding installation, configuration, and execution of Safety Tool software. To assure correct usage of the software tool, follow the instructions, guidelines, warnings, and caution presented in this manual. The Eaton Safety Tool manual is specific for FS and S-ABZ cards.

FS and S-ABZ cards are designed for the secure monitoring and halting of the drive in the event of a hazardous or unforeseen occurrence necessitating a safe response from the safety-related control system.

FS and S-ABZ cards are designed only for the PowerXL DX1 Drive.

FS card must be configured by Safety Tool before using.

FS card incorporates various safety features suitable for implementing safety functions across different applications, including emergency stops and safe speed limitations.

S-ABZ card is needed for the various safety functions. For these a compatible encoder must be used.

When integrating the Drive into a machine, it must not be put into operation until it's verified that the corresponding machine complies with the safety and protection requirements outlined in the Machinery Safety Directive 2006/42/EC (for example, by adhering to EN 60204). Users are responsible for ensuring that machine usage aligns with relevant EU Directives.

The CE markings on the drive and the cards signify compliance with the European Union's Low Voltage and EMC Directives (Directives 2006/95/EC, EMC 2004/108/EC, and ROHS 2011/65/EU) when utilized in their standard drive configuration.



Always observe the technical data and connection conditions! For additional information, refer to the equipment nameplate or label on the frequency inverter and the documentation. Any other use will be considered as an improper use of the device.

The safety requirements for the application are defined in the system specific risk assessment. The system integrator must obey those requirements when implementing safety functions with the FS or S-ABZ cards.

#### **WARNING**

Observe the technical data and connection requirements described in the manual. Any other usage constitutes improper use.

#### ***WARNING***

The product must adhere strictly to all relevant safety standards, local regulations, and directives, as well as the specified requirements and technical specifications. It should be installed away from hazardous ATEX zones. Before using the product, a comprehensive risk assessment must be conducted considering the intended application. Following the assessment, suitable safety measures should be put in place accordingly.

## 1.7 System Overview

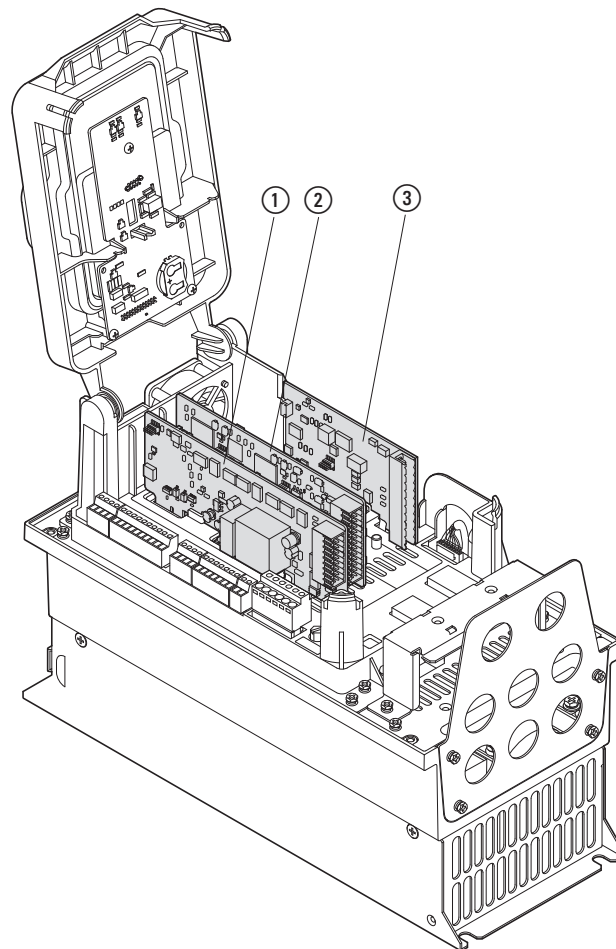

- ① S-ABZ card
- ② FS card
- ③ Fiber card
- ④ I/O Card

Figure 2: Integration of FS and S-ABZ cards in a safety application

### **WARNING**

Do not do maintenance work on the electrical parts of the drive or the motor before you isolate the drive system from the main supply!

- If the FS or S-ABZ cards malfunction, it must be replaced with a new one as it is not repairable. Ensure to document the safety configuration during the initial setup and after successfully completing validation tests for the safety functions.

## 2 Installation

This chapter describes the installation of Safety Tool. The user of PC must have administrator privileges to be able to complete the installation and if required the uninstallation.

### 2.1 Compatibility overview – software and firmware

Before installing, ensure that the software version is compatible with the safety cards. The following shows the versions of the software and firmware with which the PowerXL DX1 is compatible with FS and S-ABZ cards to Safety Tool.

<b>Product</b>	<b>Software/Firmware Version</b>
Control Board	CB_DSP: V02.00.0000 CB_MCU: V02.00.0000
FS Card	V01.00.0000
S-ABZ Card	V02.00.0000
Safety Tool	V1.0.0

## 2 Installation

### 2.2 Installation Procedure

#### 2.2 Installation Procedure

- ▶ Run the file from the folder where you have the installation files for Safety Tool.
- ▶ Wait for installation to prepare and do not click on cancel button.

#### Safety Tool - InstallShield Wizard

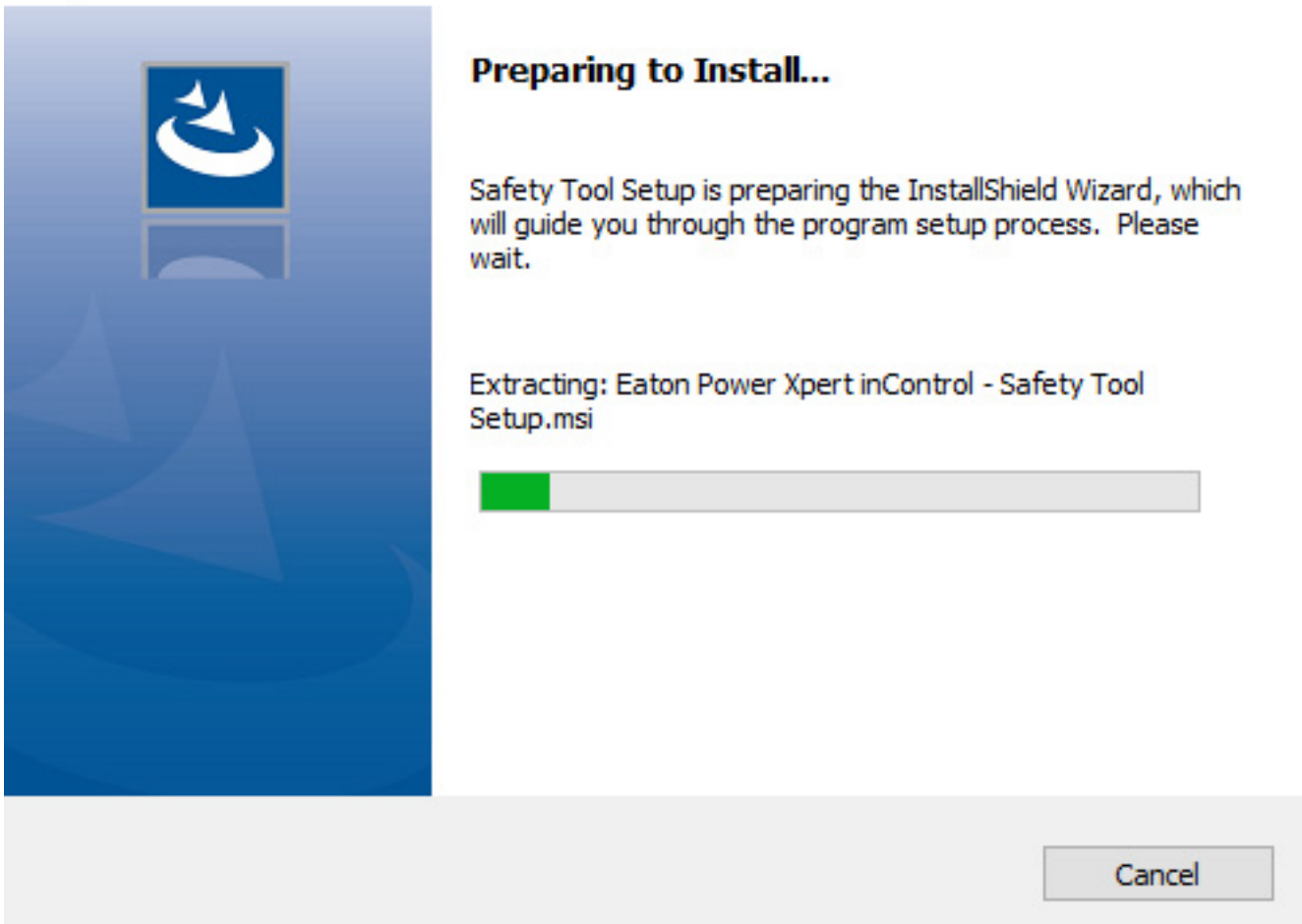

- ▶ When welcome to the InstallShield wizard for Safety Tool window is shown, click on the Next > button.

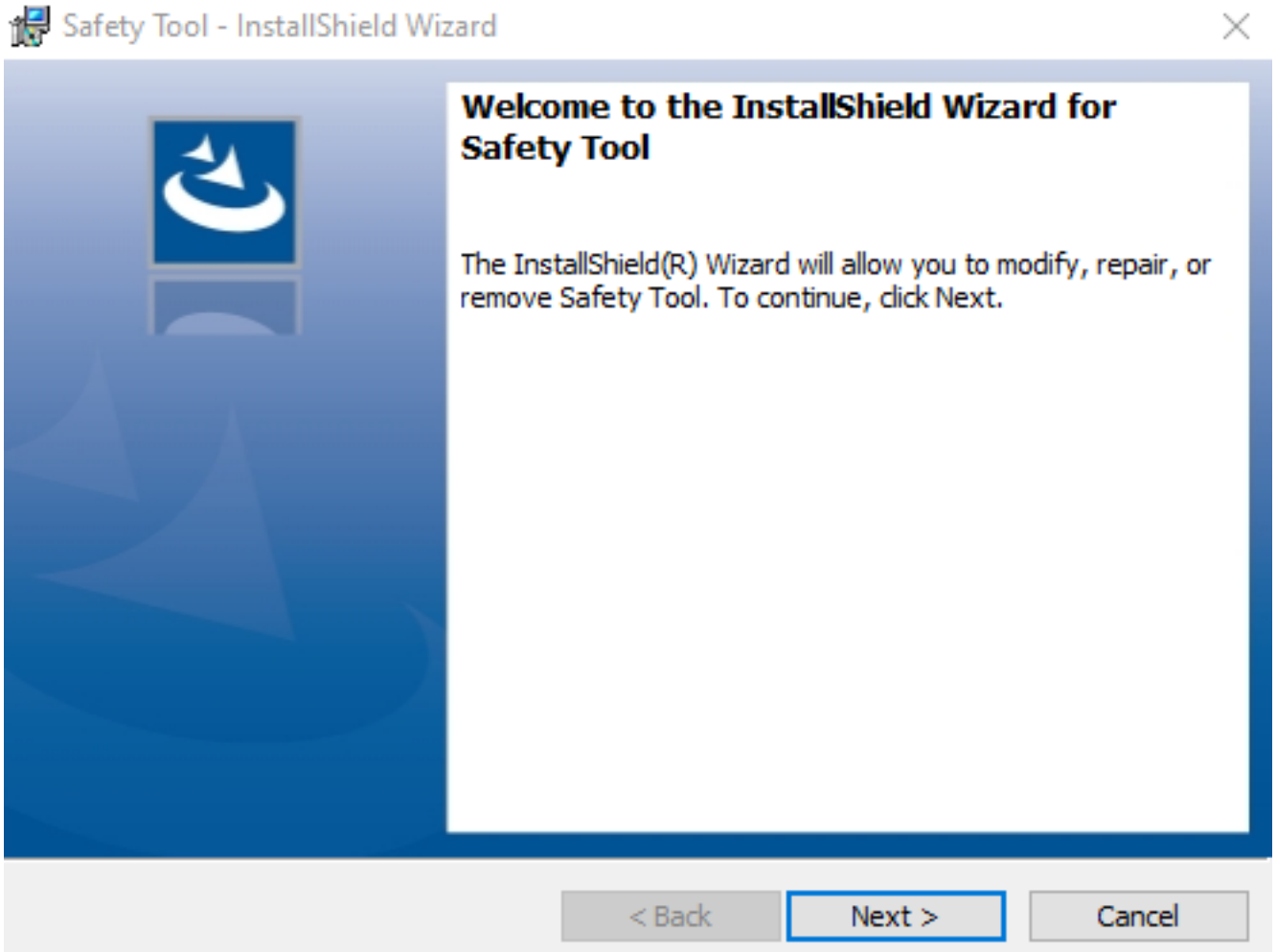

## 2 Installation

### 2.2 Installation Procedure

- ▶ Accept License Agreement and press Next > button.

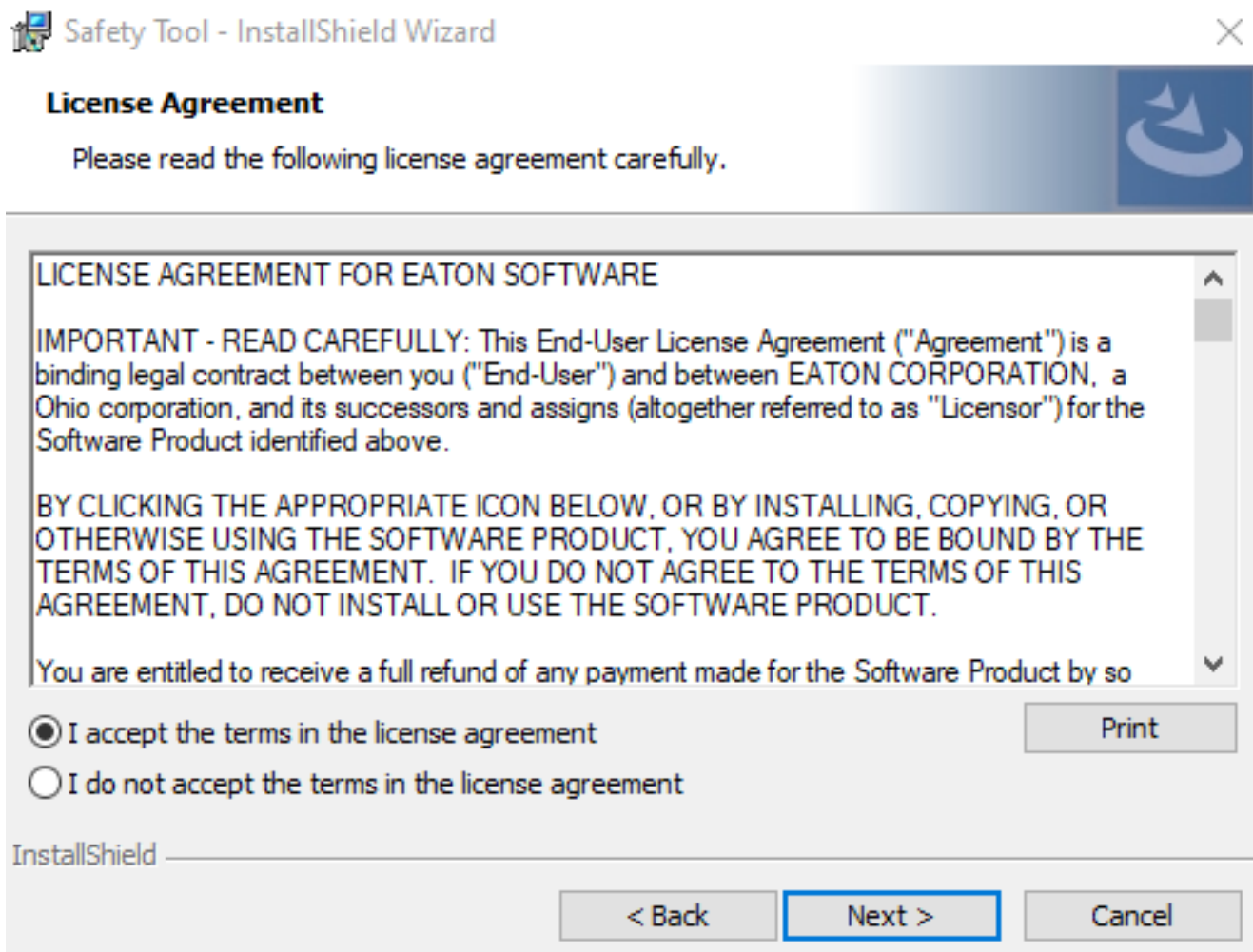

- ▶ Destination folder selection window will appear, select destination folder for installing Safety Tool using Change button and then click on next button.

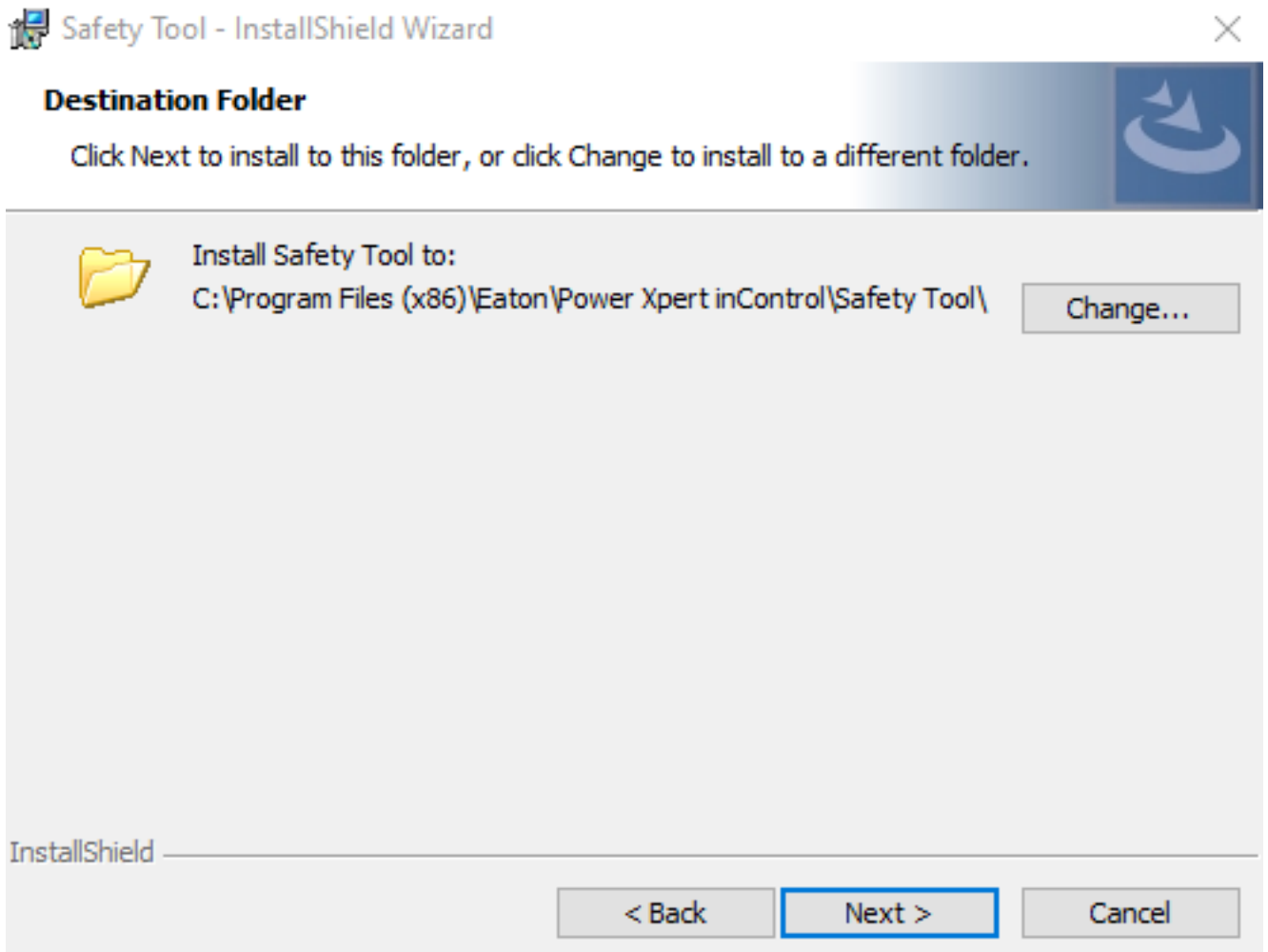

## 2 Installation

### 2.2 Installation Procedure

- ▶ Ready to install window will appear, click on Install button and wait for installation.

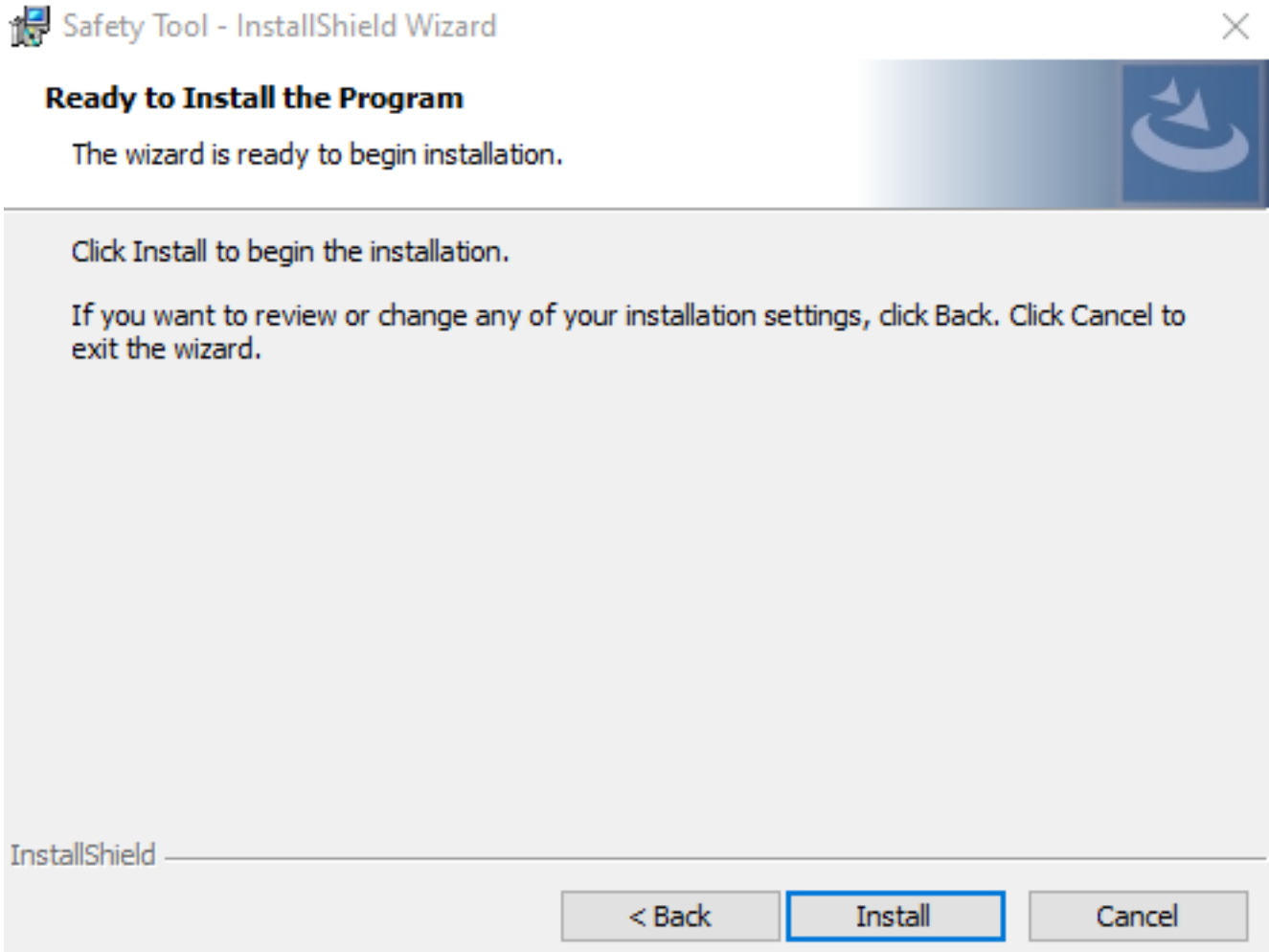

- ▶ After loading time the InstallShield wizard completed window will appear and select launch Safety Tool checkbox and click on Finish button. After pressing Finish button Safety Tool will launch, and you will see tool window.

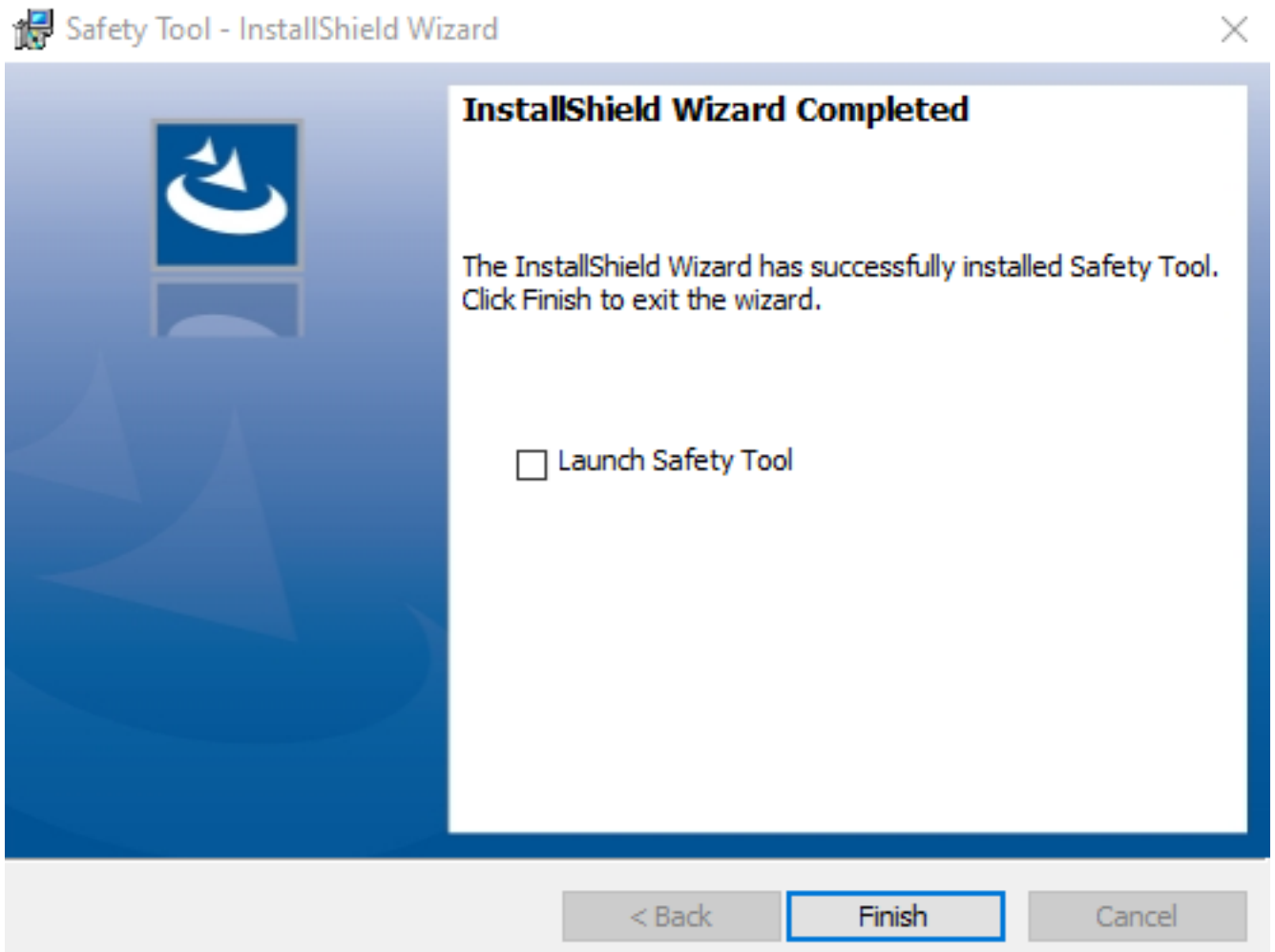

## 2 Installation

### 2.3 Uninstallation Procedure

#### 2.3 Uninstallation Procedure

- ▶ To uninstall Safety Tool from Windows, open Control Panel and click on Uninstall a program under Programs tab. Select Safety Tool in the open window and click Uninstall in the top menu bar.

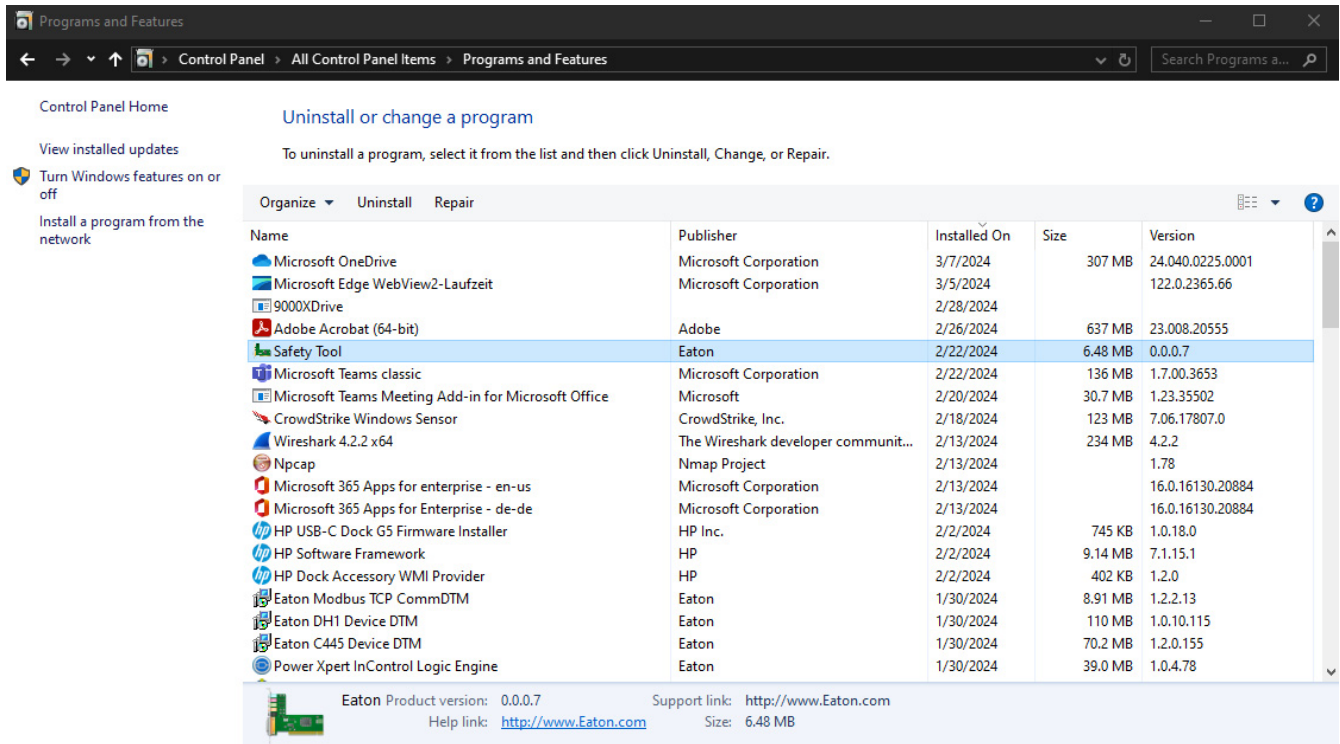

- ▶ The pop up window below will ask if you are sure to uninstall Safety Tool.

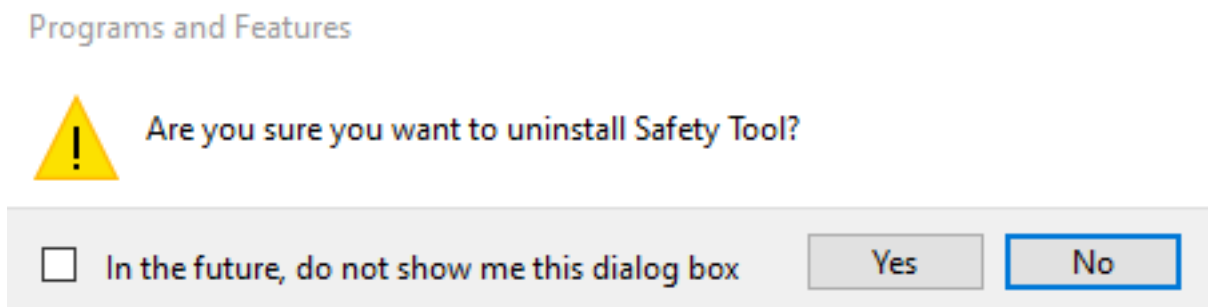

- ▶ Click on Yes and Safety Tool will be removed after uninstall progress.

## 2.4 Software Update Procedure

If the software update of the tool is required, this can be done as below.

If you have one version already installed on your system, then for the next version setup .EXE will automatically detect whether the same tool is already installed or not on your system. Follow the steps below:

- ▶ Run the file from the folder where you have the installation files for Safety Tool. You will get pop-up window to upgrade or downgrade the Safety Tool. Press Yes button and wait for installation wizard to extract all files.
- ▶ The software will run an automatic update.

### Safety Tool - InstallShield Wizard

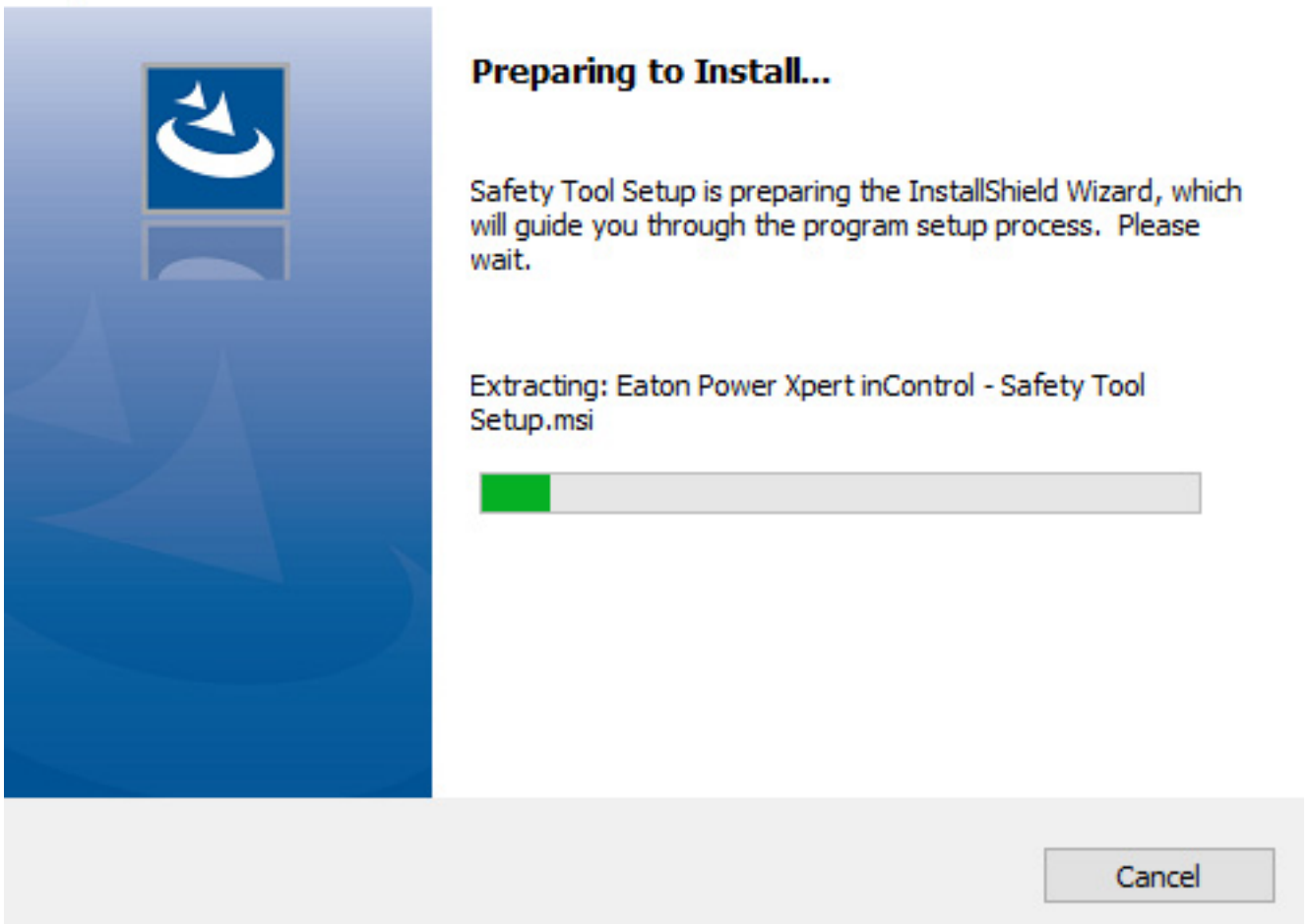

- ▶ Follow the same steps which you have followed for installation procedure. The final step will update the existing software.

### 3 General information on safety functions

The DX1 offers 11 safety functions including STO, SS1, SS2, SOS, SLA, SAR, SLS, SSR, SSM, SDI and SBC. The safety functions SS1, SS2, SOS, SLA, SAR, SLS, SSR, SSM, SDI and SBC are executed by FS or S-ABZ cards.

The control board (with STO function) will be standard configuration for each drive, while FS or S-ABZ cards (with all other safety functions) are optional. FS and S-ABZ cards can be plugged onto the control board via the connector and are located inside the housing of the entire frequency inverter, where they are protected.

All DX1 drives have the same control board, FS and S-ABZ cards have the same safety functions. Each size in each voltage range has the same hardware design, including the power sections.

### 3.1 STO

The DX1 variable frequency drives include the STO function (STO = Safe Torque Off) as part of their standard range of functionalities.

The STO (Safe Torque Off) function prevents motor from torque generating. This safety function corresponds to an uncontrolled stop in accordance with stop category 0 of IEC 60204-1.

This function meets the requirements for variable speed drive systems defined in Part 5-2 of the IEC 61800 standard and ensures that torque generating energy is no longer able to act on the motor shaft and that unintended starting is prevented.

Drive shuts down motor torque by shutdown of PWM when STO function is triggered by user.

STO function can be triggered by user via STO terminals located on control board. There is no STO terminal on FS card.

**DANGER**

The STO function is an electronic mechanism that doesn't provide sufficient protection against electric shock. Additional potential isolation measures may be required (e.g., switch-disconnector).

**CAUTION**

When used in conjunction with permanent magnet motors and in the likely case of multiple output semiconductors (IGBTs) failing, having the STO function activated may result in a motor shaft rotational movement of  $180 \text{ degrees/p}$  ( $p = \text{Number of motor pole pairs}$ ).

→ STO is located on control board and is a standard configuration for DX1. It can be used alone without FS or S-ABZ cards.

## 3 General information on safety functions

### 3.2 Other Safety Functions

#### 3.2 Other Safety Functions

The safety features provided by the safety card aim to uphold safety standards or avert potentially dangerous situations. In certain scenarios, supplementary safety systems external to the primary system, such as a mechanical brake, might be imperative for maintaining safety in the absence of electrical power.

The setup of the safety module can exclusively be performed through the designated software Safety Tool. Failure to comply with this prerequisite will result in the safety module being disregarded by the drive system.

Its role is to oversee the operations of the drives and carry out safety protocols. The inputs and outputs of the safety module can be customized to align with specific safety requirements. Requests to activate or deactivate safety functions received by user (push buttons, magnetic switches, or safety PLCs connected to the safety card). Thus, activation requests for safety functions can occur automatically, such as through sensor activation, or manually, like through switch activation.

Safety functions (SS1, SS2, SOS, SLA, SAR, SLS, SSR, SSM, SDI and SBC) can only be achieved by standard drives together with option cards (FS or S-ABZ cards) and external safety encoder. FS card DI terminals can be used to activate these functions and DO terminals can be used to output these functions' status or perform some safety functions. Configuration of these safety functions must be achieved via Safety Tool.

All safety functions located on FS card can only be triggered by FS card DI. FS card DI cannot trigger STO function directly but can only trigger STO through other safety functions indirectly. FS card DO can be configured to output safety function status based on user application requirement.

#### 3.3 Safe state

The safety options go to a safe state if it detects an error. In safe state STO is activated. The STO circuit in the drive is open.

Reset means to enable the function again. DX1 cannot be auto reset once it's in safe state.

At safe state The SS1, SS2, SOS, SLA, SAR, SLS, SSR, SDI functions stops motor from generating torque.

#### 3.4 Response Time

Response time means the time from safety function request received to safety function start to execute.

For all safety functions in FS card (SS1, SS2, SOS, SLA, SAR, SLS, SSR, SSM, SDI and SBC), the response time is less than 40 ms.

### 3.5 Safety Related Parameter

The basic parameters can be configured by user. The DOs can be configured to output safety function status based on user application requirement.

A detailed selection of each safety functions are described in → Table 2 below. A complete list of parameters with descriptions are → chapter 5, "List of Parameters".

Table 2: Parameter selection of safety functions

Parameters	Selection	Parameters	Selection	Parameters	Selection
Basic Parameters	Encoder Pulse Count	SOS Function	SOS Enable	SLA Function	SLA Enable
	Max Speed		SOS Source		SLA Source
	DO1 Mode		SOS n = 0 - Hysteresis		SLA t-delay
	DO2 Mode		SOS Acknowledgement Mode		SLA+ trip limit
SS1 Function	SS1 Enable	SS2 Function	SS2 Enable	SSR Function	SSR Enable
	SS1 Source		SS2 Source		SSR Source
	SS1 Mode		SS2 Mode		SSR upper limit
	t-delay STO@SS1		t-delay STO@SS2		SSR t-delay
	SS1 n = 0 Limit		SS2 n = 0 Limit		SSR Acknowledgement Mode
	SS1 Acknowledgement Mode		SS2 Acknowledgement Mode		SAR Function
SBC Function	STO SBC Mode	SSM Function	SSM Enable	Ramp time to zero	
	STO SBC delay		SSM Source	Deceleration tolerance	
	SS1 SBC speed		SSM Limit	Monitor Function	Encoder speed
	SBC feedback action		SSM Hysteresis		Encoder position
SLS Function	SLS Enable	SDI Function	SDI+ Enable		Encoder direction
	SLS Mode		SDI- Enable		DI status
	SLS-t delay		SDI Mode	DO status	
	SLS Source		SDI+ Source	STO status	
	SLS trip limit		SDI- Source		
	SLS limit		SDI-t delay		
	SLS Acknowledgement Mode		SDI Limit degree		
	SDI n = 0 Limit				
	SDI Acknowledgement Mode				

## 4 Commissioning

This chapter describes the operation of Safety Tool and its configuration for each safety function.

### 4.1 User Access Levels

Before using Safety Tool the operator must be familiar with the access level and their requirements.

User Access Levels are supported by the drive itself and customizes the interface to the drive accordingly. The Safety Tool supports different access levels.

#### 4.1.1 Access to User Levels

- Observer:
  - Permissions: Read-only access.
  - Password Requirement: Yes.
  - Details: Users with Observer access can view data and parameters but cannot make any changes. This level is typically used for monitoring purposes, ensuring that users can check the system's status without the risk of altering any settings.
- Operator:
  - Permissions: Read-only access.
  - Password Requirement: Yes.
  - Details: Operators can read and view parameters but cannot modify them. This access level is suitable for users who need to understand the system's current state and performance but do not need to adjust. It ensures that critical settings remain unchanged while still providing necessary information.
- Installer:
  - Permissions: Read-write access to all parameters.
  - Password Requirement: Yes.
  - Details: Installers have full access to read and modify all parameters. This level is intended for users responsible for setting up and configuring the system. They can make necessary adjustments to ensure the system operates correctly and efficiently.
- Eaton:
  - Permissions: Read-write access to all parameters.
  - Password Requirement: Yes.
  - Details: Like the Installer level, Eaton access allows users to read and write all parameters. This level might be designated for specific roles or personnel within the organization, possibly those with advanced technical knowledge or higher authority to make significant changes.

Each access level is designed to balance security and functionality, ensuring that users have the appropriate permissions for their roles while protecting the system from unauthorized changes.

### 4.1.2 Assigning Password

Click on connect button.

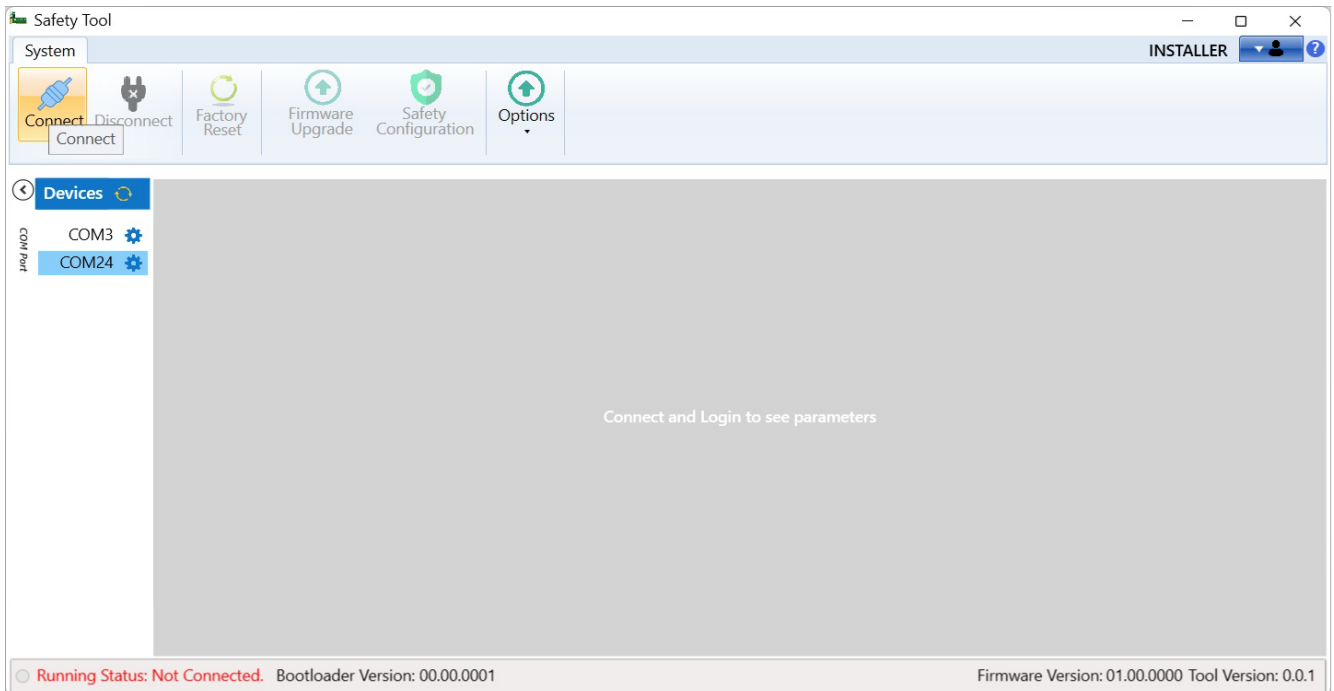

User Access window pops up. Select User Level and enter the correct Password.

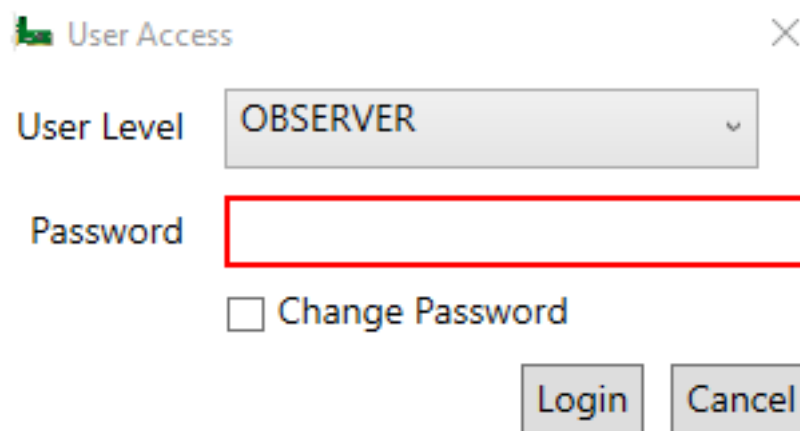

4 Commissioning  
4.1 User Access Levels

Incorrect password will return error message on the text box.

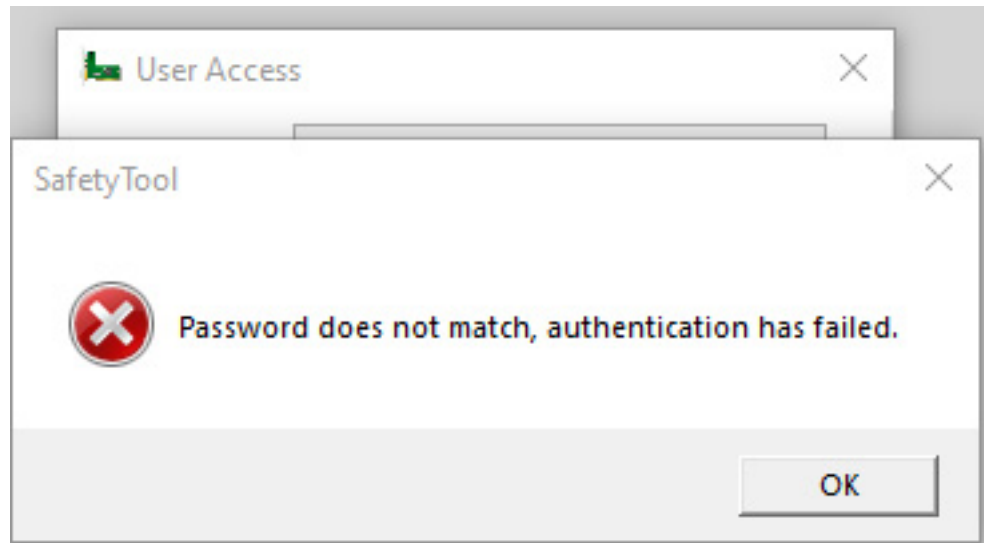

By pressing Change Password a new password can be assigned:

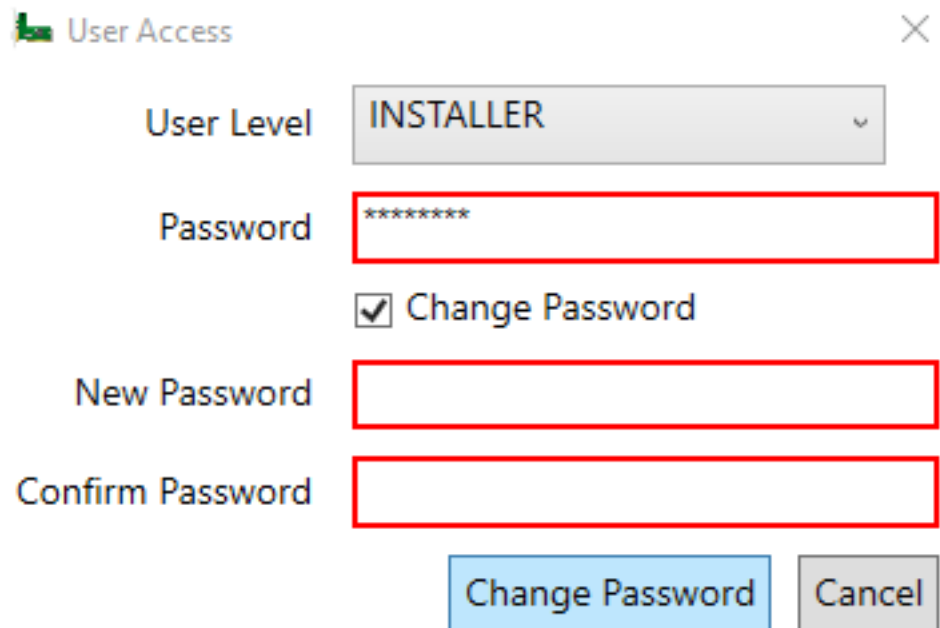

If user enters incorrect character, then the user will get the error message below.

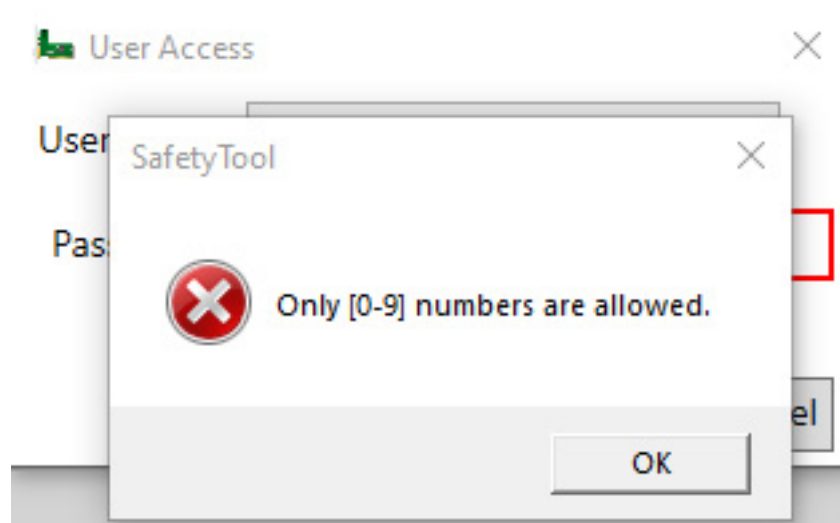

## 4.2 Serial Port Settings

Power XL DX1 drive only supports serial communication for Safety Tool interaction,

The separate serial configuration settings can be used where user can change according to PC port settings.

Serial communication requires RS485 (DXX-CBL-PCCABLE cable of which one end is connected to drive and another end is connected to PC). FS card should be plugged into the drive.

Follow the steps below to configure the application for serial communication with FS card.

- ▶ Open Safety Tool from start menu
- ▶ Click on Settings icon of COM port.

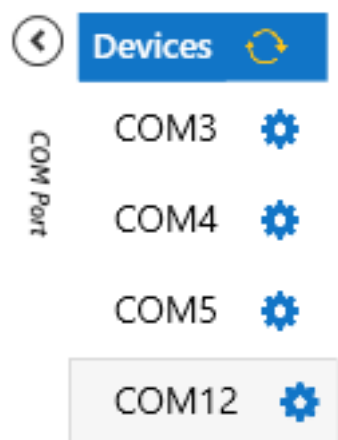

## 4 Commissioning

### 4.2 Serial Port Settings

- Settings for selected COM port will open as you can see in the screenshot below.

Settings for COM12

Slave Address: 1

Baud Rate: 19200

Word Length: 8

Parity: Even

Stop Bits: One

Refresh Rate: 2000

OK

Table 3: Settings

Setting	Description
Slave address	Represents the address of specific device. Usually, it is unsigned parameter.
Baudrate	Supported baudrates: 4800, 9600, 14400, 19200, 38400, 56000, 57600, 115200, 128000, 256000
Word length	Read bytes length (7 or 9).
Parity	Supported parity bits: Even, Odd, Mark, Space
Stop bit	Supported stop bits: One, Two, One point five

### 4.3 Connecting and Disconnecting to the FS or S-ABZ cards

- ▶ Make the connection between PC and the Drive.
- ▶ Plug FS card and S-ABZ card into right slots.
- ▶ Power on the Drive.
- ▶ Run Safety Tool on PC.
- ▶ Configure the COM ports.
- ▶ Click on Connect button on the top tab of the main window.
- ▶ Safety Tool establishes the serial connection to FS or S-ABZ cards.

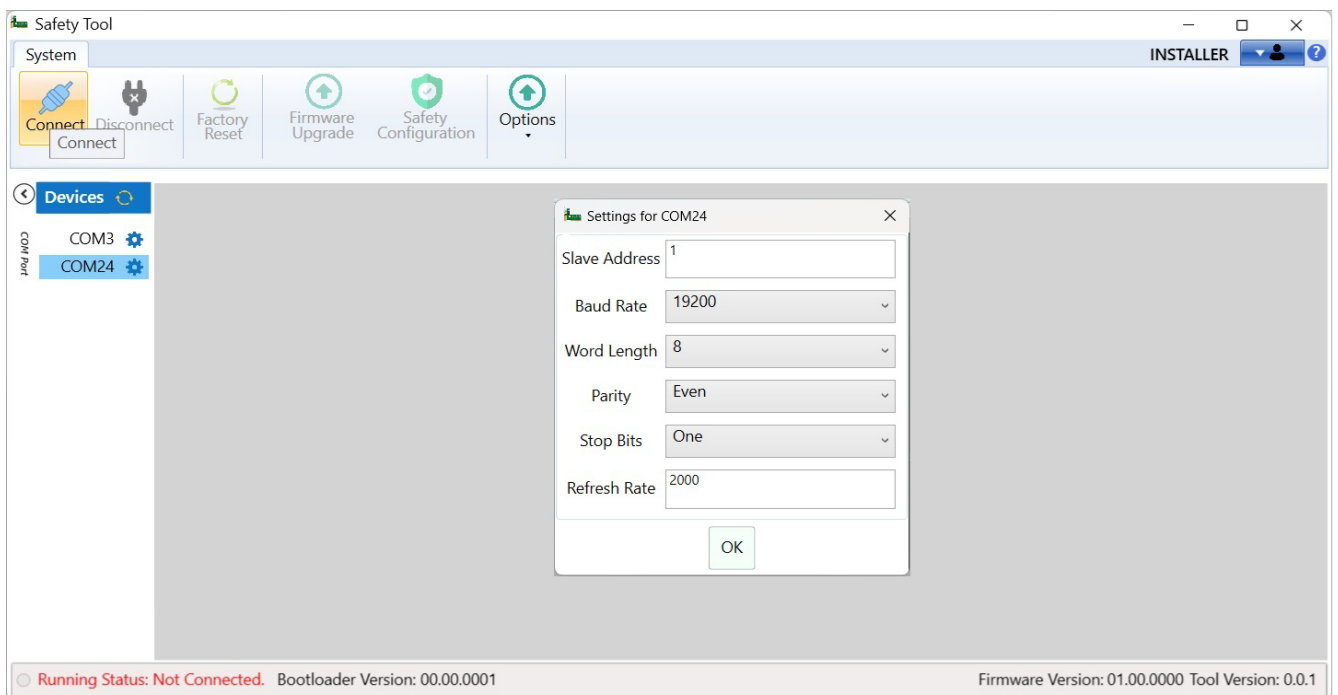

## 4 Commissioning

### 4.3 Connecting and Disconnecting to the FS or S-ABZ cards

- ▶ Disconnect button disconnects Safety Tool from FS card

The screenshot displays the Safety Tool software interface. At the top, there is a 'System' bar with an 'INSTALLER' label and a user profile icon. Below this is a navigation bar with several icons: 'Connect', 'Disconnect', 'Factory Reset', 'Firmware Upgrade', 'Safety Configuration', and 'Options'. The 'Disconnect' button is highlighted with a tooltip that also says 'Disconnect'. The main interface is divided into three sections: 'Devices', 'Safety Parameters', and 'Safety Configuration'. The 'Devices' section shows two COM ports: 'COM3' and 'COM24'. The 'Safety Parameters' section lists parameters P1 through P12. The 'Safety Configuration' section shows parameters P1.1 through P1.6 with their respective values and units. At the bottom, there are 'Set All' and 'Reset All' buttons. The status bar at the very bottom shows 'Running Status: Connected', 'Bootloader Version: 00.00.0001', 'Firmware Version: 01.00.0000', and 'Tool Version: 0.0.1'.

Parameter	Value	Unit
P1.1 Encoder Pulse Count	1024	ppr
P1.2 Max Speed	1,500.00	rpm
P1.3 DO1 Mode	0: Not Used	
P1.4 DO2 Mode	0: Not Used	
P1.5 Safety Card Configuration	1: FS + SABZ Card	
P1.6 DO Pulse Width	0: 1 ms	

## 4.4 Factory reset

Factory reset allows the user to reset the FS card to its original state. This feature is designed to restore all parameter values to their default settings, ensuring that the system returns to its initial configuration. This can be particularly useful in troubleshooting scenarios or when preparing the system for a new user.

When the user presses the Factory Reset button, the system initiates the reset process. During this process, all custom settings and configurations are erased and replaced with the default values. Once the reset is complete, the user will receive a message on the screen indicating whether the reset was successful or if it encountered any issues. This feedback helps the user to confirm that the reset has been performed correctly or if further action is needed.

→ Factory reset resets the current password, and 12345678 becomes the master password. The user can use this to log in.

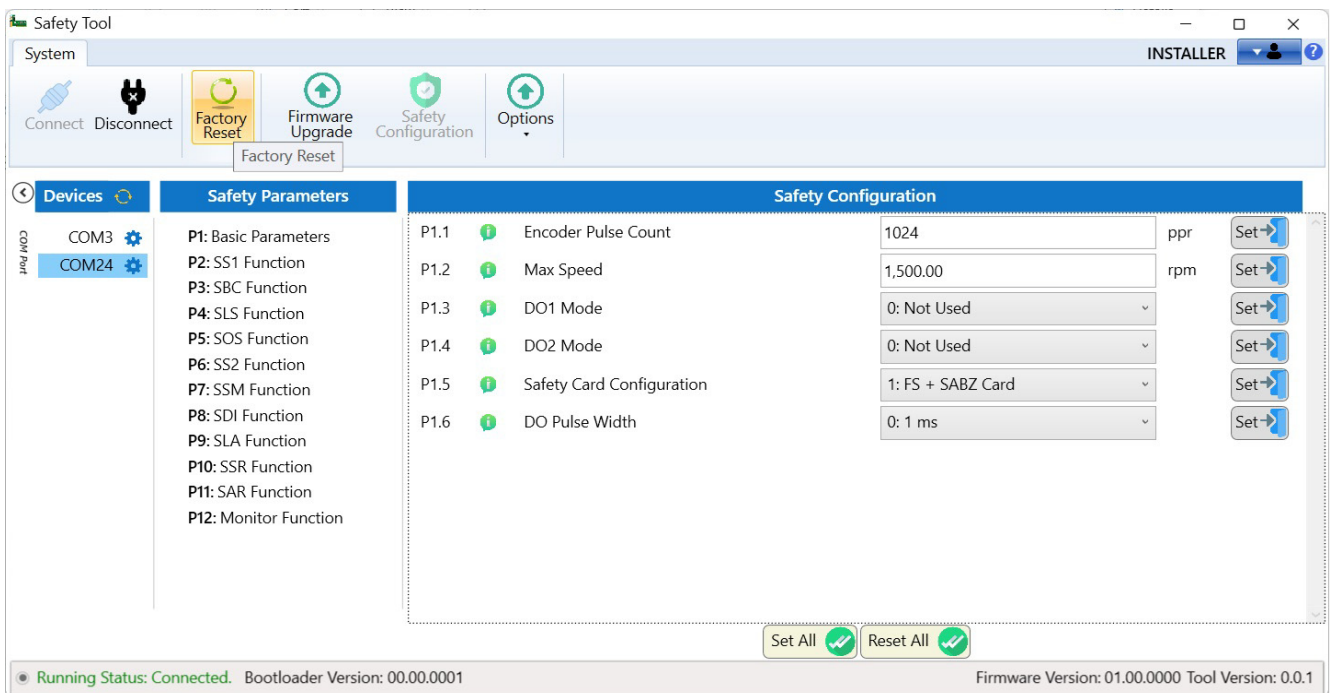

## 4 Commissioning

### 4.5 Information Panel

### 4.5 Information Panel

The information panel provides crucial details about FS card, including connection status, firmware version and bootloader version.

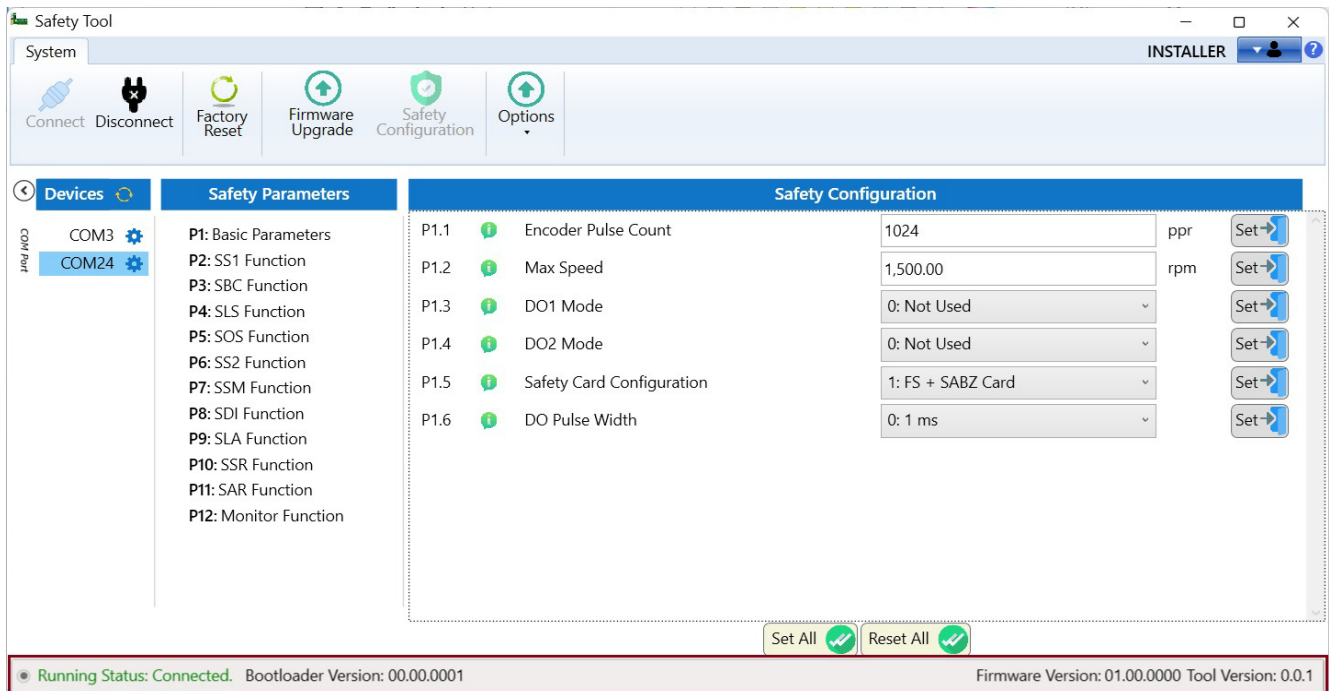

Firmware version displays package or firmware version of functional safety card.

Running Status, After clicking on Connect or Disconnect button the status of connection to Functional Safety Card will display with help of color. Green color for online and red color for offline.

## 4.6 Safety Configuration and Firmware Upgrade

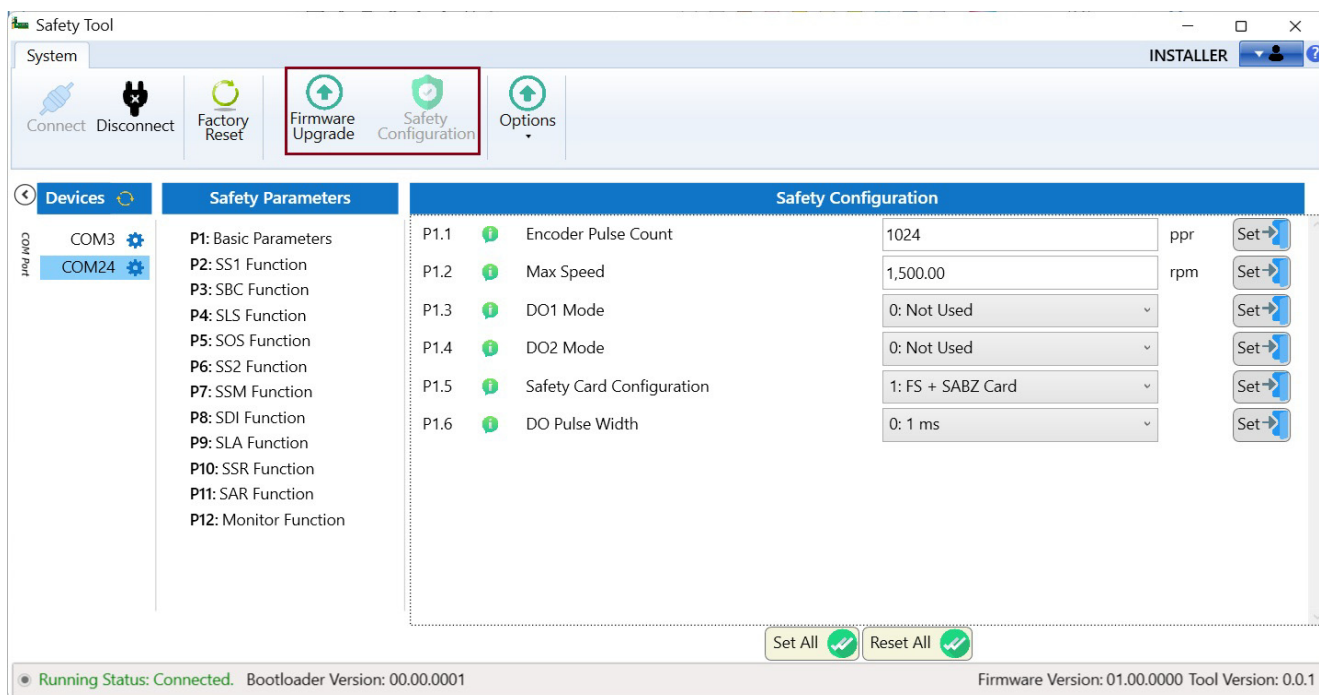

These buttons help the user switch between the parameter configuration/setting page and the firmware upgrade UI (User Interface). When the user clicks on the Firmware Upgrade button, they can access the firmware upgrade UI page. If the user clicks on the Safety Configuration button, they can access the parameter configuration/setting page.

- **Firmware Upgrade Button:** When the user clicks on this button, they are directed to the firmware upgrade UI page.
  - This page is designed for updating the firmware of FS card. Firmware upgrades are essential for improving performance, adding new features, and fixing bugs. The UI typically guides the user through the upgrade process, ensuring that the latest firmware version is installed correctly.
- **Safety Configuration Button:** Clicking this button takes the user to the parameter configuration/setting page.
  - This page allows users to configure and adjust various parameters related to the safety functions of the card. Users can set specific values, enable, or disable features, and customize settings to meet their operational requirements. This configuration ensures that the safety system operates according to the desired specifications and standards

## 4 Commissioning

### 4.7 Parameter Structure

#### 4.7 Parameter Structure

The menu structure displays all safety functions, each containing its associated parameter configurations. The screenshot below highlights the tree view of the menu structure. When the user clicks on a menu item, as shown in the screenshot above (with Basic Parameter selected), the associated parameters of that group will be displayed on the right side of the screen (Safety Configuration). Here, the user can monitor and configure the parameters.

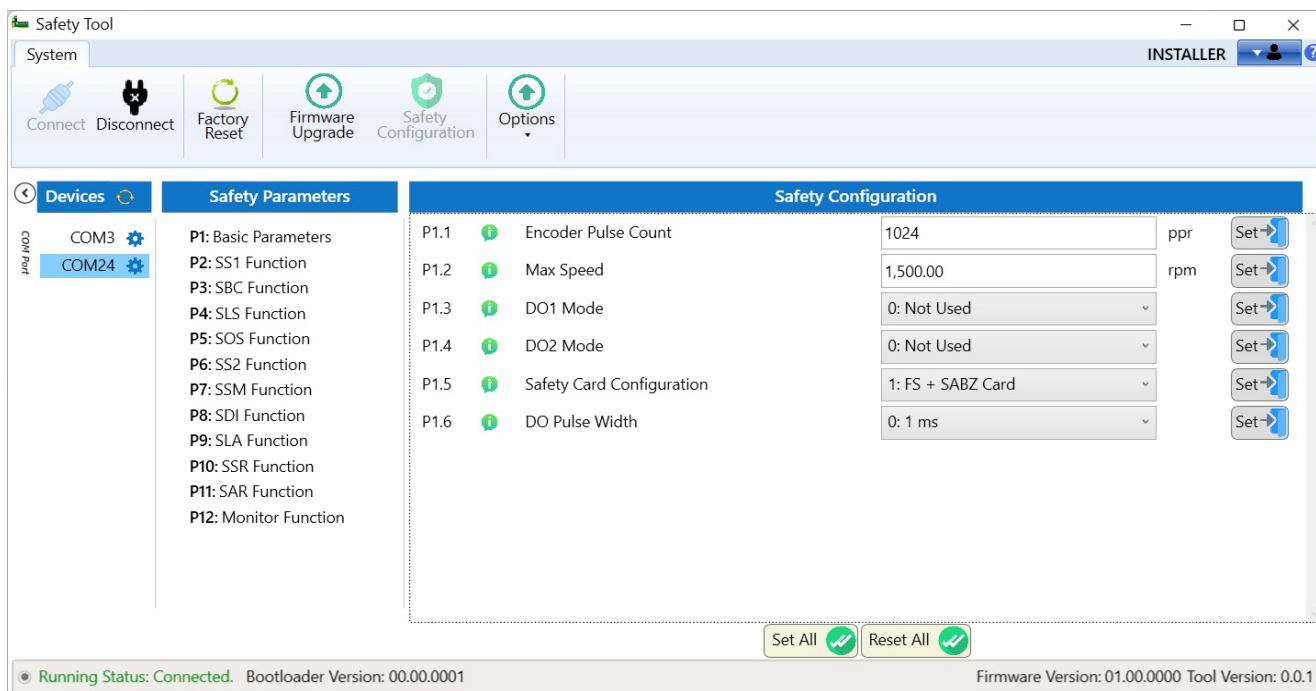

The menu structure is a hierarchical tree view that lists all the safety functions available in the system. Each function is represented as a node in the tree, and expanding a node reveals its associated parameter configurations.

- This structure helps users navigate through different safety functions and their settings efficiently. It provides a logical and intuitive way to access various parameters without overwhelming the user with too much information at once.

This design ensures that users can efficiently navigate and manage the safety functions of the system, providing both clarity and control over the configuration process.

## 4.8 Parameter Settings

### Offline

The offline view of the Safety Tool is designed to provide users with a comprehensive look at the tool's interface and functionalities, even when not connected to the system.

All UI components of the Safety Tool are visible in this mode. This includes menus, buttons, configuration panels, and status indicators, providing a complete overview of the tool's capabilities.

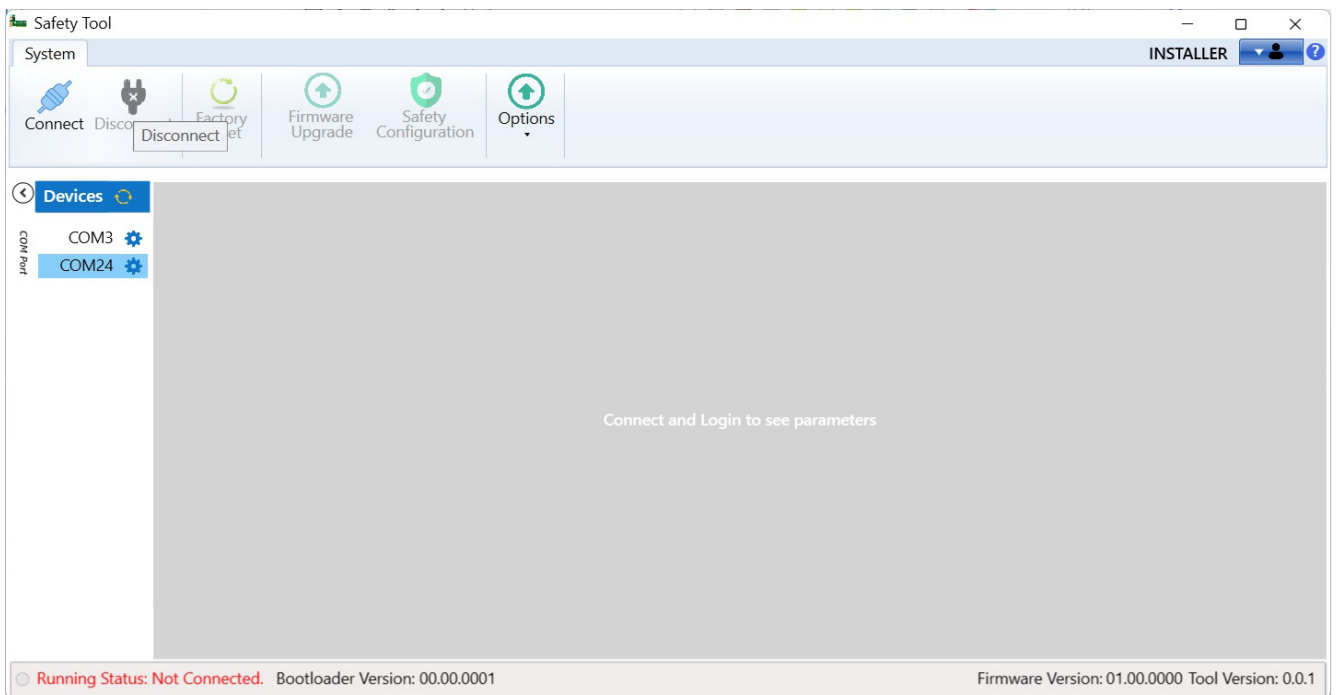

## 4 Commissioning

### 4.8 Parameter Settings

#### Online

The online view of the Safety Tool displays all UI (User Interface) components of the Safety Tool. Depending on the user access level, users can read/write parameters and upgrade the firmware of FS card. In the screenshot below, the parameters are shown in edit mode.

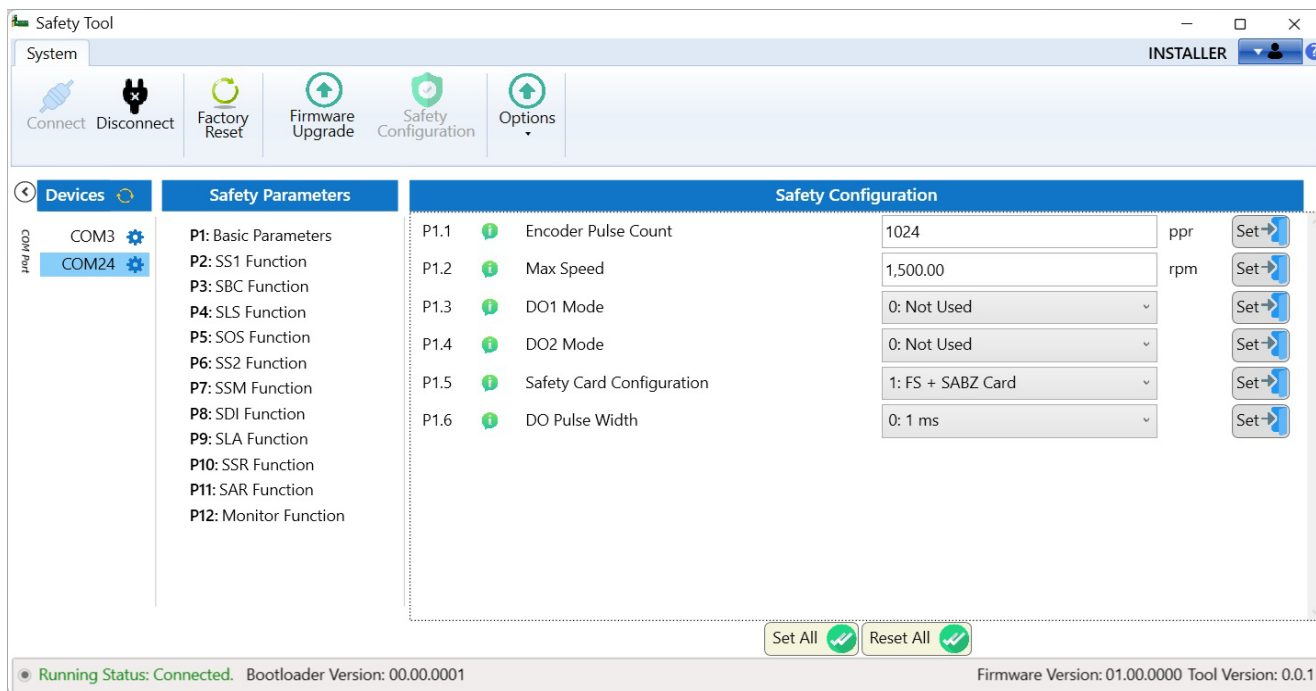

#### Default, Min & Max view

In the Safety Tool, we display the default, minimum, and maximum values of parameters, as well as the DCI parameter name. Users must move the cursor over the **i** icon to display a tooltip with all details. This helps users identify the valid range of the parameter.

- **Default Value:** This is the pre-set value that the parameter will revert to if no changes are made. It serves as a baseline for the parameter's operation.
- **Minimum Value:** The lowest allowable value for the parameter. This ensures that the parameter does not go below a certain threshold, which could potentially cause issues or unsafe conditions.
- **Maximum Value:** The highest allowable value for the parameter. This prevents the parameter from exceeding a safe or functional limit.

<b>i</b> SLA- trip limit	-30.00	rpm/s	Set →
<b>i</b> Default: -3000	-5.00	rpm/s	Set →
<b>i</b> Min: -6000000	1,000.0	ms	Set →
<b>i</b> Max: 0	0		Set →
-----			
<b>i</b> DCI Parameter: DCI_SLA_negative_TripLimit			Set →
<b>i</b> Parameter Name: SLA- trip limit			

### Set the value

Set button helps user to update and add new value to parameter.

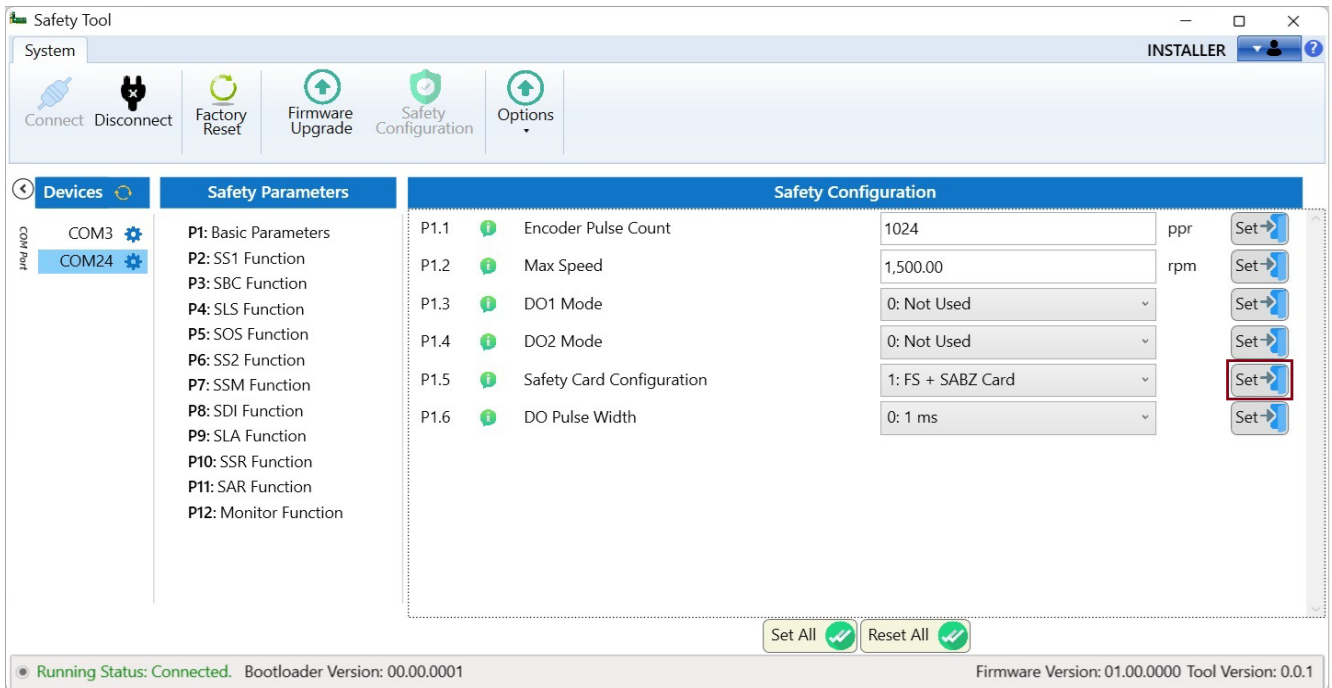

All parameters need to be written on both MCUs of FS card. For verification, the following window will appear after pressing the Set button.

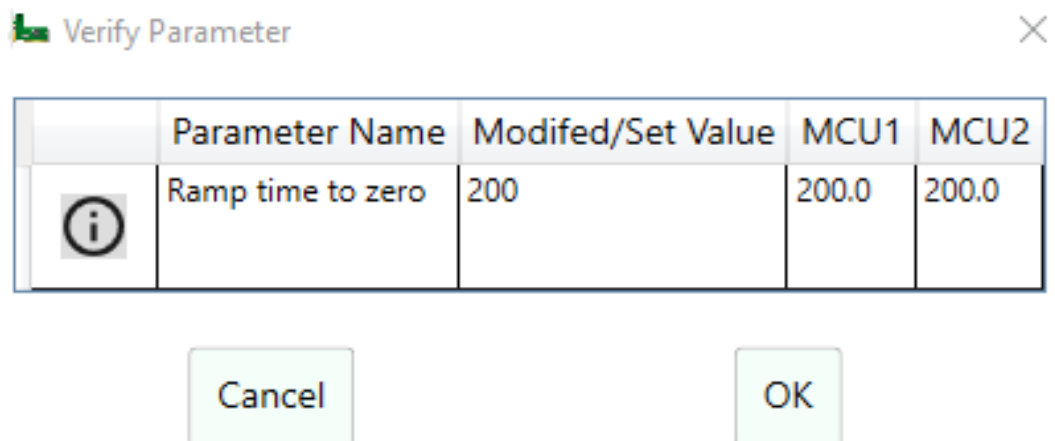

## 4 Commissioning

### 4.8 Parameter Settings

#### Set all values

Set All button enables user to update and add new values to parameter which is currently selected in the menu structure.

→ Reset all button is only use to reset values enter by user.

After clicking on Set ALL user will get verification dialog box (2<sup>nd</sup> screenshot).

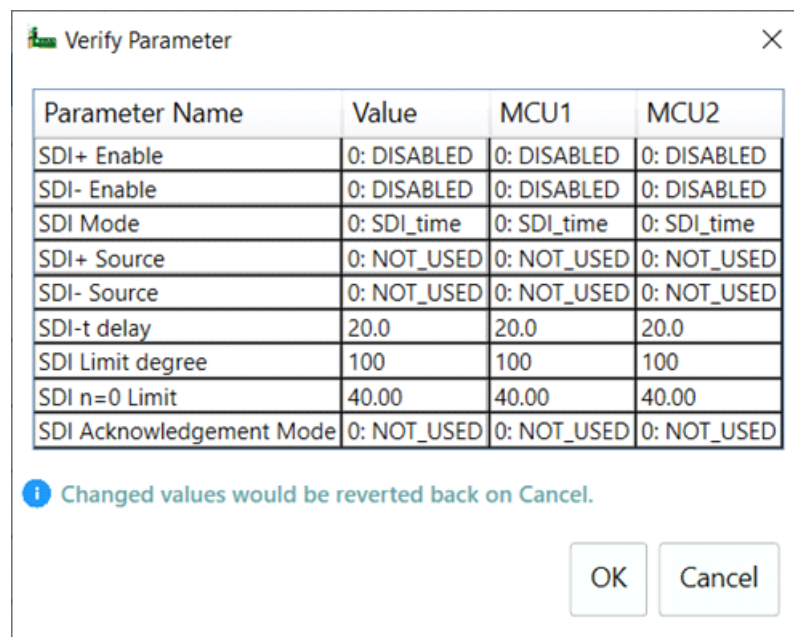
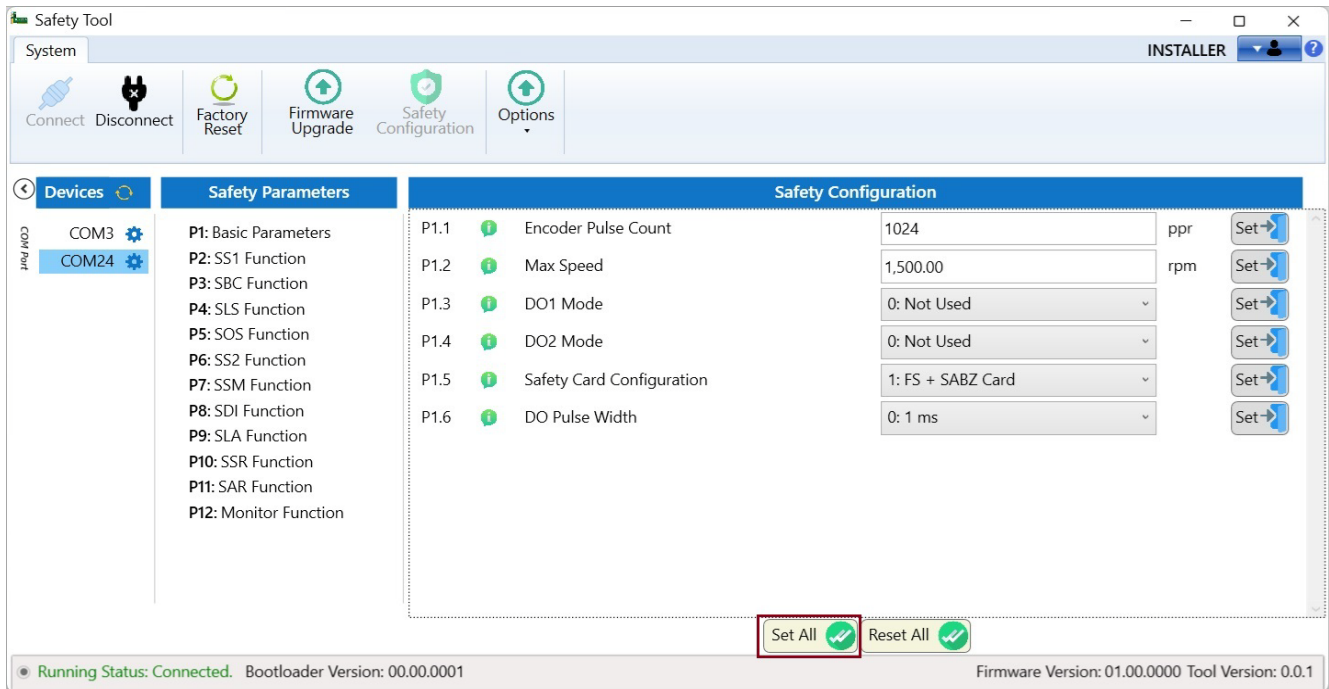

### Reset all values

Reset All button resets all parameter values entered by the user.

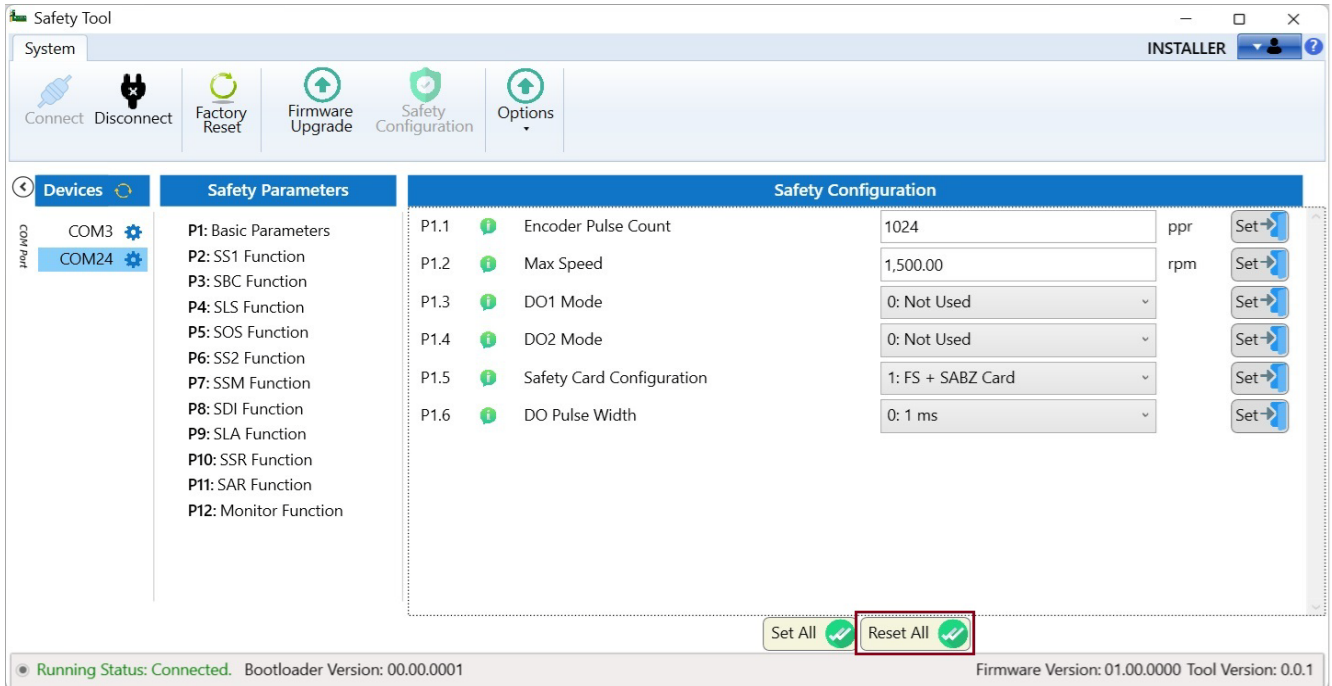

## 4 Commissioning

### 4.9 Firmware Upgrade and Downgrade

#### 4.9 Firmware Upgrade and Downgrade

A firmware upgrade is the process of replacing a product's existing firmware with a newer version of the firmware code for the same product. This upgrade process enhances the product's efficiency and performance by incorporating the latest changes and improvements in the firmware.

Conversely, a firmware downgrade is the reverse process of a firmware upgrade. It involves resetting the current version of the firmware code to an older version. This procedure prepares the device to operate with a lower version of the firmware code, which might be necessary if the newer firmware has issues or if compatibility with certain features or hardware is required.

- Benefits of Firmware Upgrades
  - "Improved Performance: Upgrades often include optimizations that make the device run more smoothly and efficiently.
  - "New Features: New firmware versions can introduce additional functionalities that were not available in previous versions.
  - "Bug Fixes: Upgrades typically address and fix known issues and vulnerabilities, enhancing the device's stability and security.
  - "Compatibility: Ensures the device remains compatible with other new hardware or software.
- Reasons for Firmware Downgrades
  - "Stability Issues: If the new firmware causes instability or crashes, downgrading can restore the device to a more stable state.
  - "Compatibility: Older firmware might be necessary to maintain compatibility with certain applications or hardware.
  - "User Preference: Some users might prefer the interface or features of an older firmware version.

#### **Prerequisites for update and downgrade:**

- ULINK (64-bit or 32-bit) software installation on the computer.
- Configuration file.
- Firmware file as bin or data package file.
- Serial connection via COM port.
- Power XL DX1 Drive with safety cards

## 4.10 User Interface for Update

To open Firmware Update tool select Firmware Upgrade on the Safety Tool.

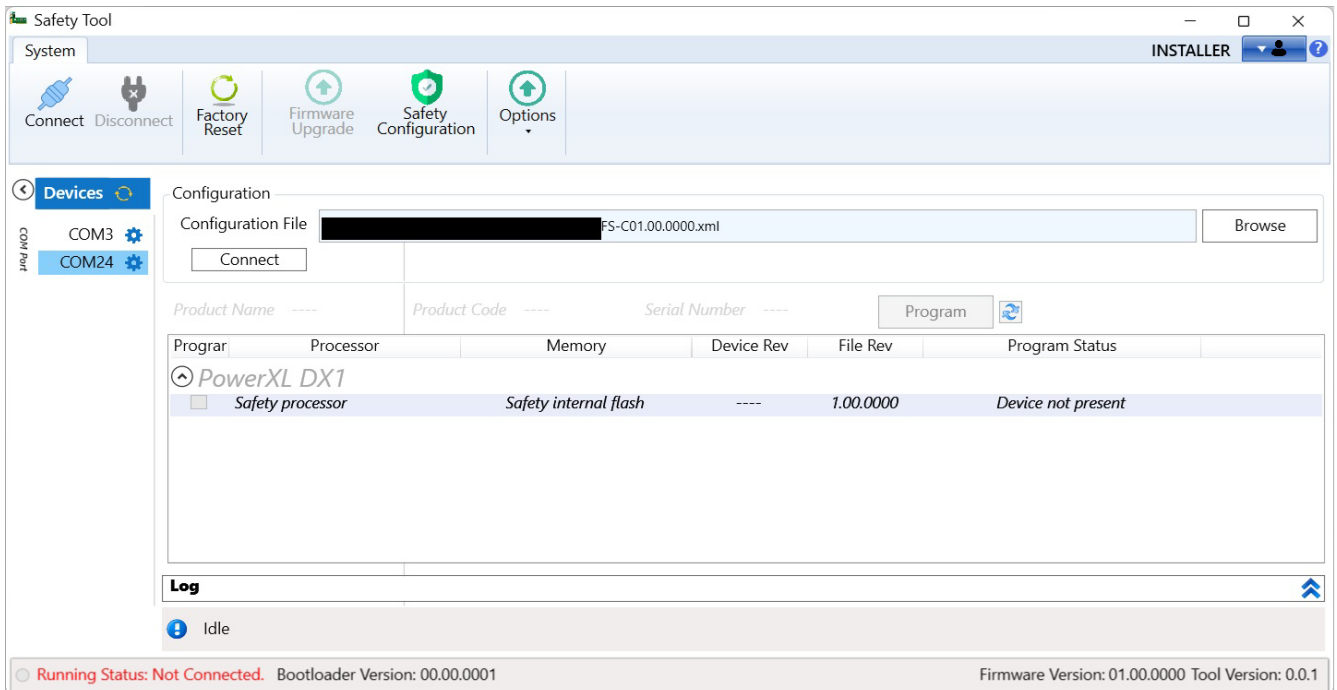

- **Browse:** The Browse button enables the user to select a configuration file. The configuration file contains all the required entries for the upgrade and downgrade processes. It also includes an entry for the data packet (bin) file. The bin file should be in the same directory as the configuration file. As shown in the screenshot below, the "FS C0.0.7" is a configuration file. Typically, the configuration file name contains the character "C," as highlighted in the image.

Name	Status	Date modified	Type
FS-C0.0.7	✓	1/18/2024 5:26 AM	Microsoft Edge HTML Document
FS-V0.0.7	✓	1/18/2024 5:26 AM	Microsoft Edge HTML Document

- **Connect:** The Connect button initiates the connection process between the device and the tool. Before connecting, the user must ensure that the correct COM port is selected. If the new COM port is not visible in the list, you can refresh the COM port list using the Refresh button. After refreshing, the new COM port entry should appear.
1. **Program:** The Program feature enables the user to upgrade and downgrade the device to a specific firmware version. It accomplishes this by using a data packet file, which is part of the configuration file.

## 4 Commissioning

### 4.11 Using the Safety tool

- Information window: This data grid control displays all the information from a specific device configuration file. For example, if we use FS card configuration file, it will only display safety-related modules, as shown in the screenshot of the FUT UI. The image information is categorized into the following parts.
  - Processor: A processing unit inside images. Some images contain multiple processors.
  - Memory: Device processor.
  - Device Revision: Displays details of specific image of connected device's firmware.
  - File Revision: Displays details of specific image from file.
  - Program Status: Shows progress of upgrade/downgrade operations. It also displays status like programming success or failure, verification OK or failed etc.
- Message/Log console: Message displays all debug and runtime console messages.
- Status Bar: Displays the status of the current operation or proces

### 4.11 Using the Safety tool

#### 4.11.1 Parameter access

Follow the steps below which will help you to understand how to use Safety Tool after installation. Each below screenshot contains a picture of the tool with highlighted section.

- ▶ Run Safety Tool via start menu.
- ▶ Configure the COM port of DX1 main board on which FS card plugged into the slot B.
- ▶ Click on the settings icon next to the COM port name.

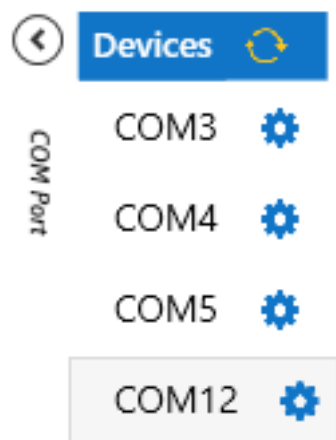

- ▶ Select the correct COM port settings according to DX1 board serial connection configuration and then click on OK button.

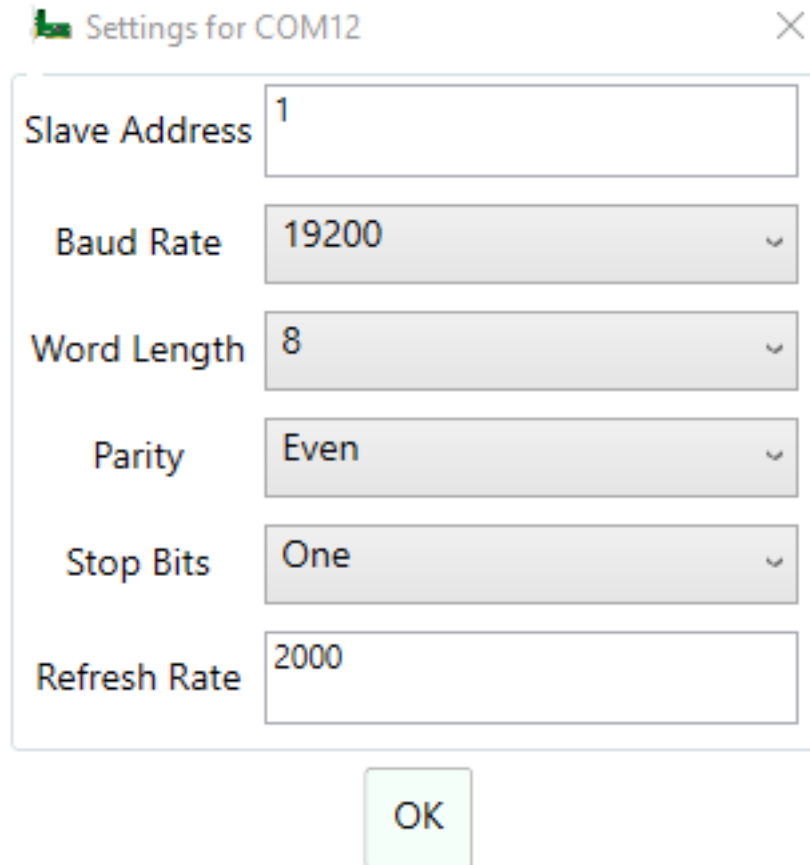

The screenshot shows a dialog box titled "Settings for COM12" with a close button (X) in the top right corner. The dialog contains the following fields:

- Slave Address: 1
- Baud Rate: 19200
- Word Length: 8
- Parity: Even
- Stop Bits: One
- Refresh Rate: 2000

Below the dialog box is an "OK" button.

- ▶ Click on Connect button on top left corner of main window which will automatically open User Access window where user needs to pick User Level and enter the Password for access.

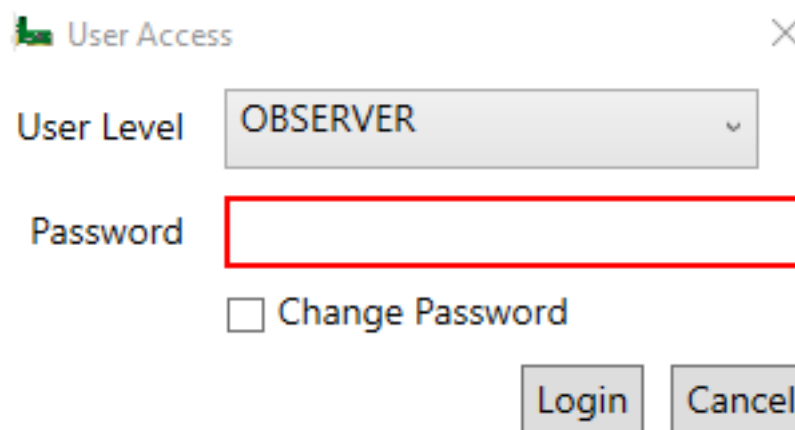

The screenshot shows a dialog box titled "User Access" with a close button (X) in the top right corner. The dialog contains the following fields and controls:

- User Level: OBSERVER
- Password: (empty field, highlighted with a red border)
- Change Password
- Login button
- Cancel button

## 4 Commissioning

### 4.1.1 Using the Safety tool

- ▶ As shown in the highlighted area of the screenshot below, click on any safety parameter menu to open the associated parameters in the right side safety configuration area.

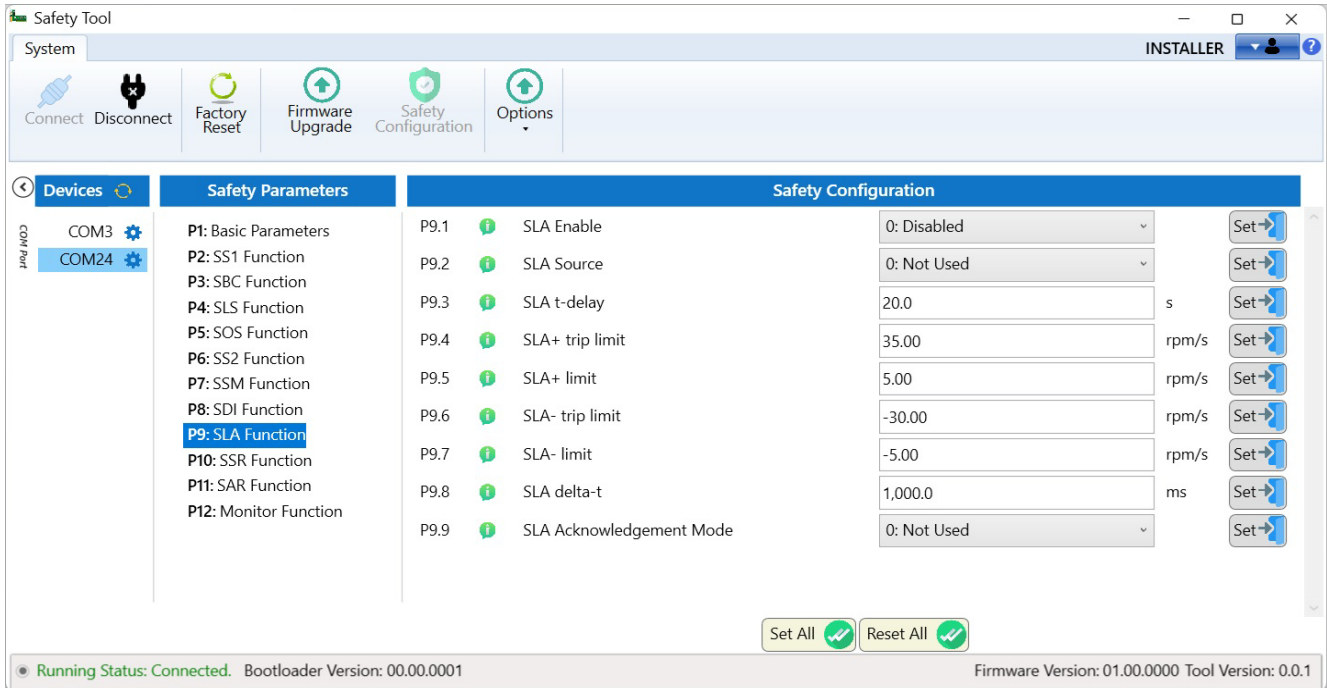

- ▶ Enter value for any specific parameter and click on Set or Set All button. User will get confirmation dialog box (as shown in 2nd screenshot).

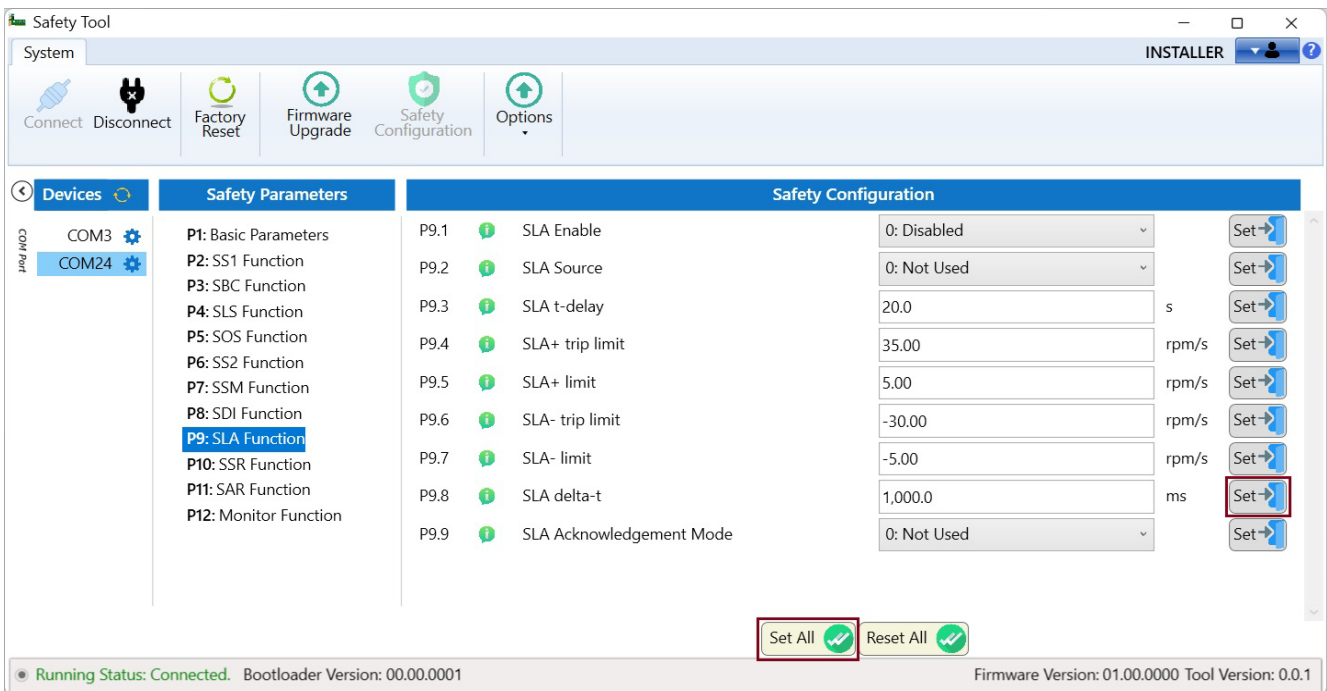

## 4 Commissioning

### 4.1.1 Using the Safety tool

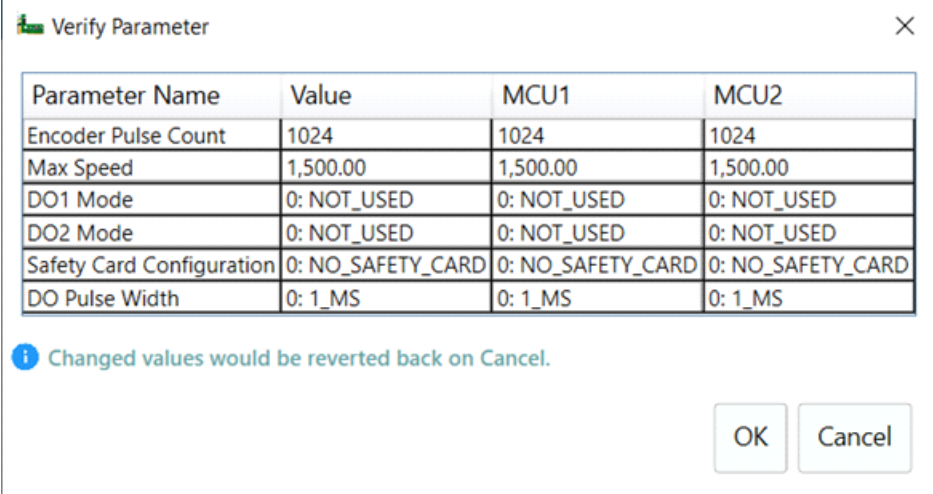
The image shows a software dialog box titled "Verify Parameter" with a close button (X) in the top right corner. It contains a table with four columns: "Parameter Name", "Value", "MCU1", and "MCU2". The table lists seven parameters: Encoder Pulse Count, Max Speed, DO1 Mode, DO2 Mode, Safety Card Configuration, and DO Pulse Width. Below the table is an information icon (i) and a message: "Changed values would be reverted back on Cancel." At the bottom right, there are two buttons: "OK" and "Cancel".

Parameter Name	Value	MCU1	MCU2
Encoder Pulse Count	1024	1024	1024
Max Speed	1,500.00	1,500.00	1,500.00
DO1 Mode	0: NOT_USED	0: NOT_USED	0: NOT_USED
DO2 Mode	0: NOT_USED	0: NOT_USED	0: NOT_USED
Safety Card Configuration	0: NO_SAFETY_CARD	0: NO_SAFETY_CARD	0: NO_SAFETY_CARD
DO Pulse Width	0: 1_MS	0: 1_MS	0: 1_MS

 Changed values would be reverted back on Cancel.

OK Cancel

## 4 Commissioning

### 4.11 Using the Safety tool

#### 4.11.2 Set Factory Settings

Following steps will provide how to reset the cards' parameters to the default.

- ▶ Click on Factory Reset button to reset FS card

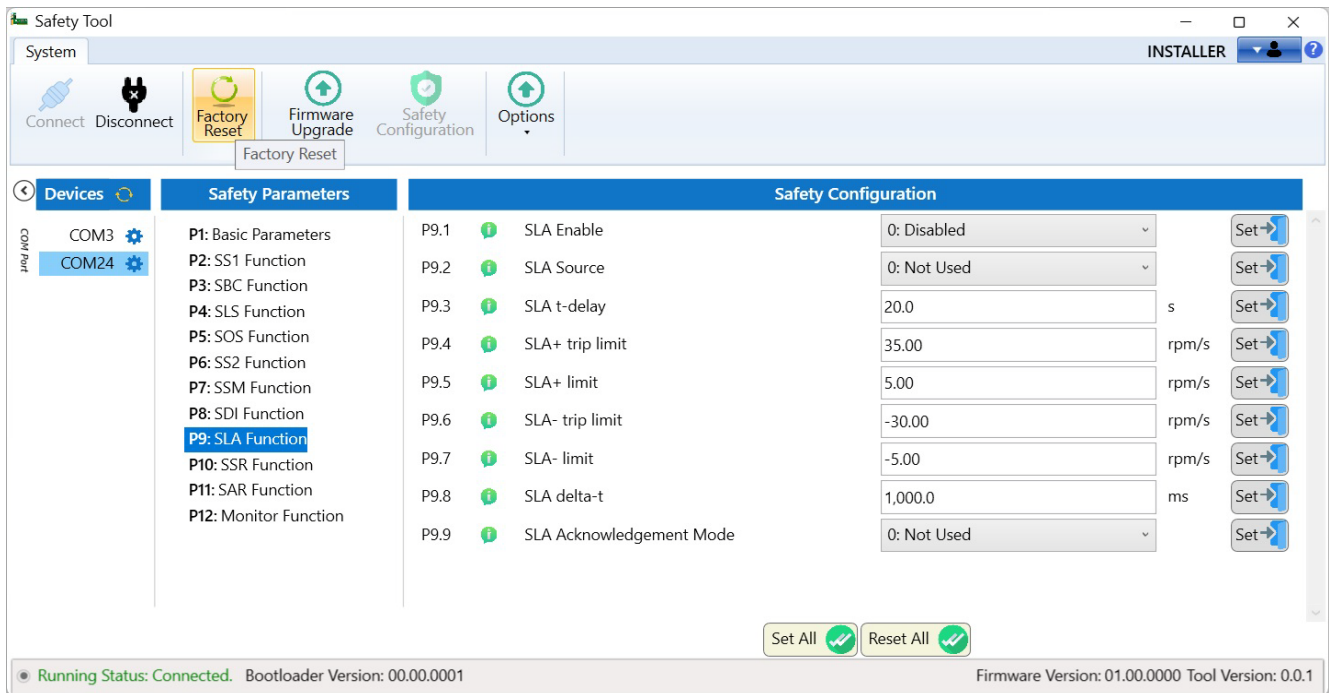

- ▶ You will get a message pop-up dialog

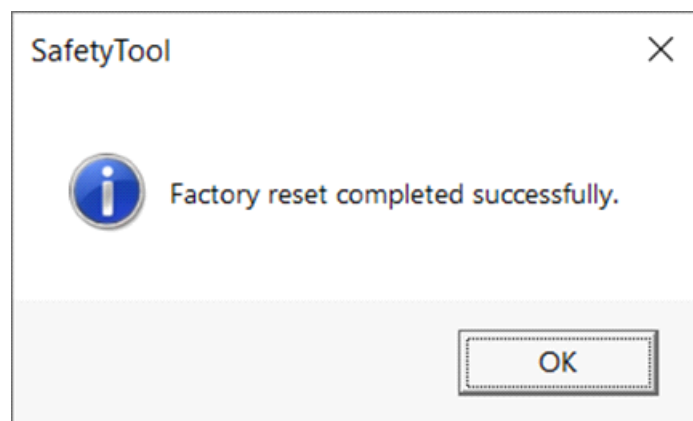

- ▶ Press Ok.

### 4.11.3 Firmware Upgrade

Follow the below steps to upgrade or downgrade FS card.

- ▶ Open the Safety Tool and click on Firmware Upgrade Tool as shown in the screenshot below, highlighted in red square mark.

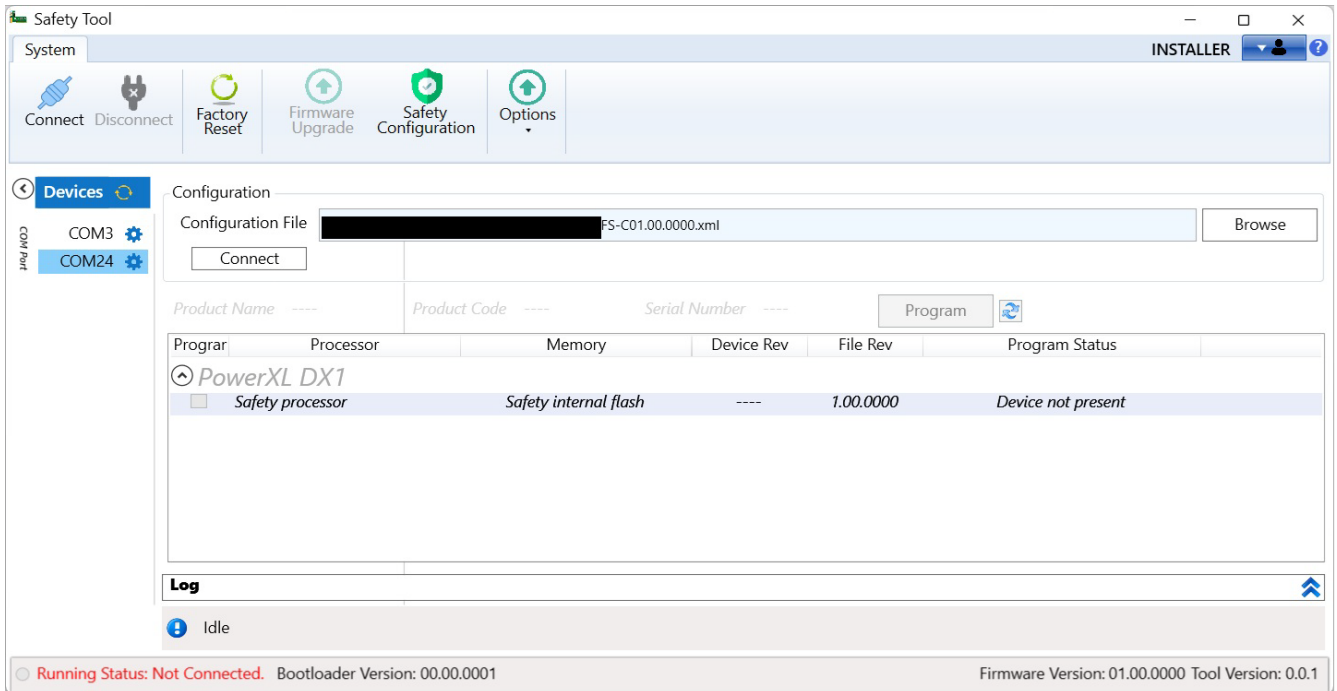

- ▶ Configure the COM port and connect to FS card according to → Section 4.2, “Serial Port Settings”. Select Installer or Eaton user access level mode.
- ▶ Click on the Browse button and select the configuration file for FS card. For example, as shown in the screenshot below, the browse dialog contains both the configuration and code pack files. Please note that the configuration and code pack files must be stored in the same folder.

Name	Status	Date modified	Type
FS-C0.0.7	✓	1/18/2024 5:26 AM	Microsoft Edge HTML Document
FS-V0.0.7	✓	1/18/2024 5:26 AM	Microsoft Edge HTML Document

## 4 Commissioning

### 4.1.1 Using the Safety tool

- ▶ After selecting configuration file, Safety tool automatically loads image from code pack file. As you can see in the below screen shot. It is showing Safety processor entry for FS card.

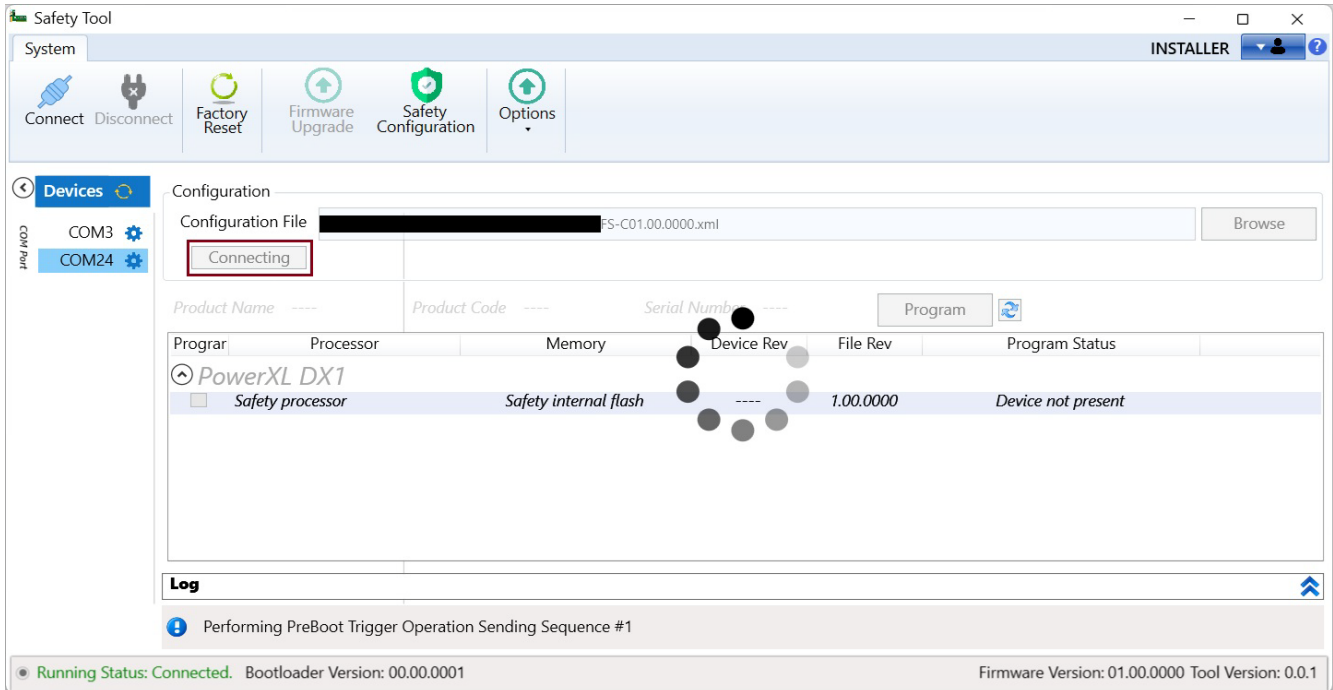

- ▶ Click on Connect button. Safety Tool sends request to capture and validate configuration of FS card. Please wait some time.

## 4 Commissioning

### 4.1.1 Using the Safety tool

- ▶ After loading is completed, you will get the License Agreement pop-up window, user must agree to the agreement to proceed.

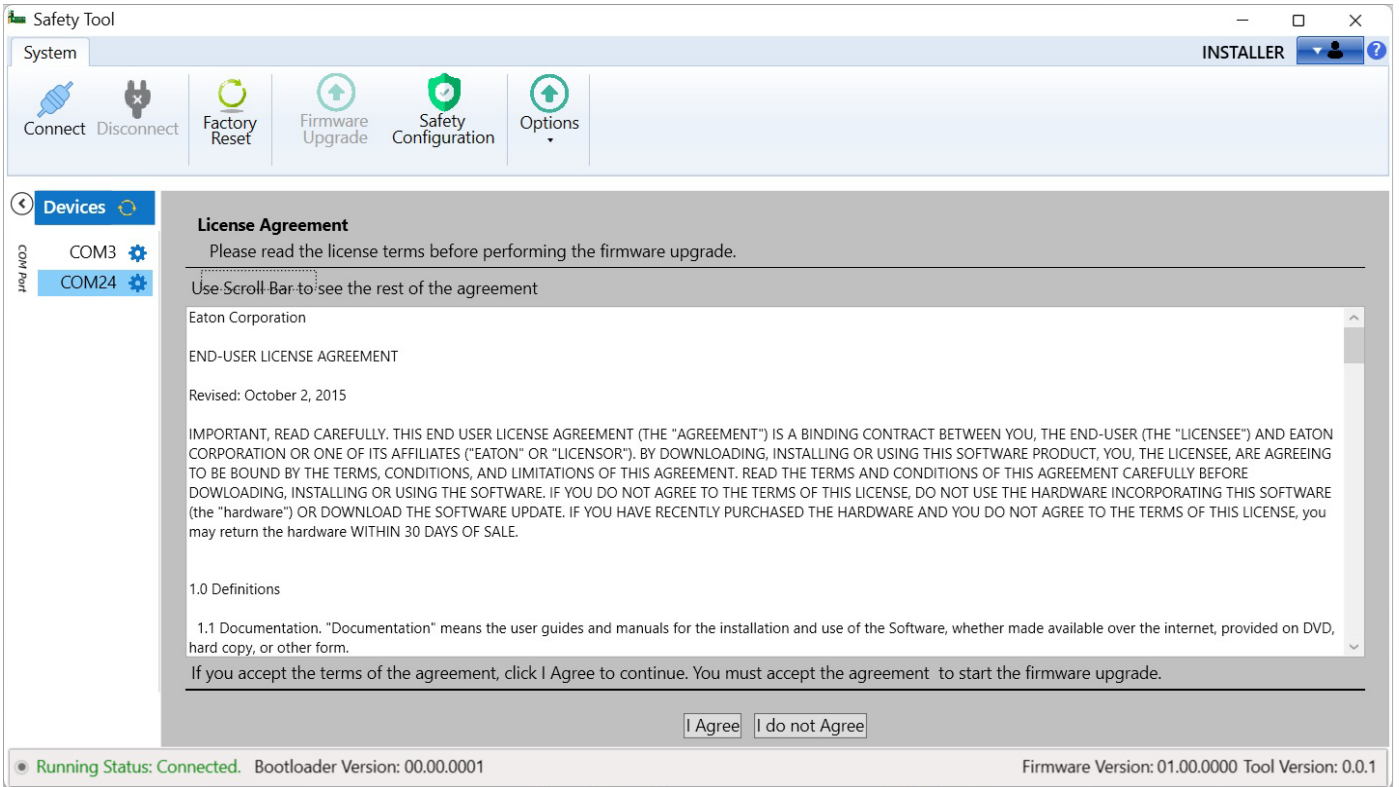

- ▶ After clicking on I Agree button, you will see the list of images related to FS card. Press **Program** button to program selected package.

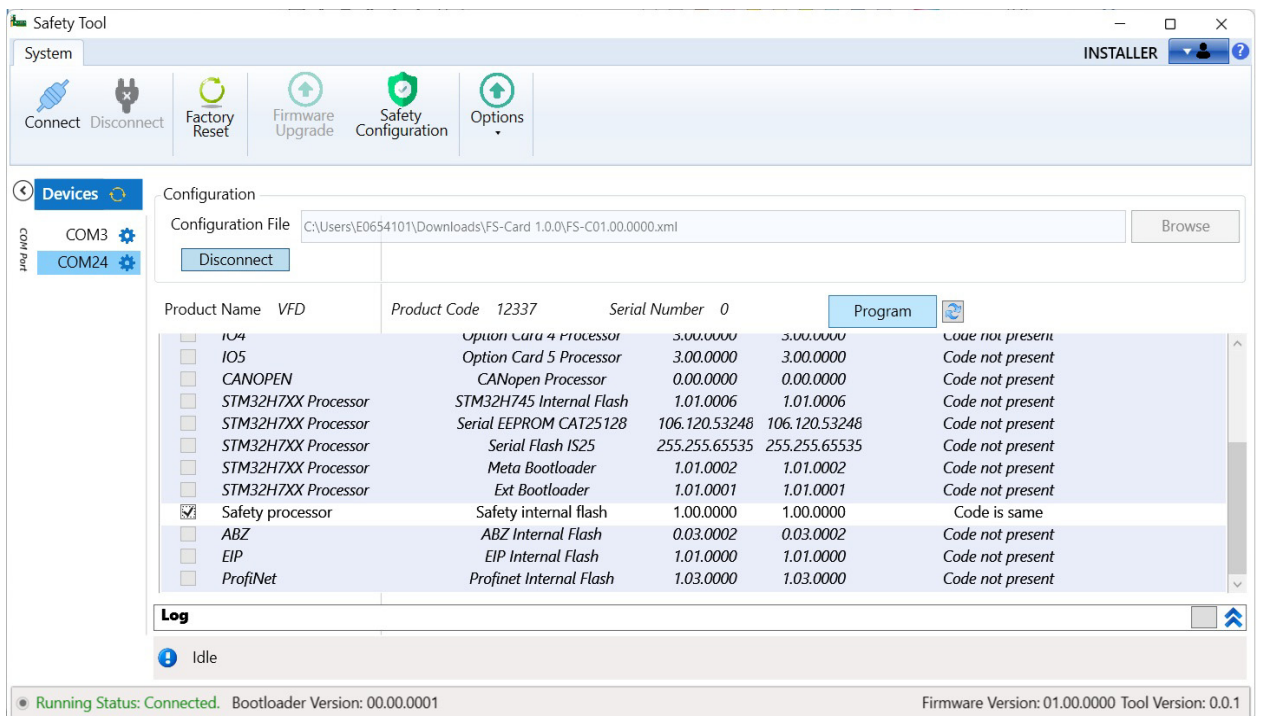

## 4 Commissioning

### 4.1.1 Using the Safety tool

- ▶ Select the Safety processor for firmware upgrade programming. To start programming, click on the Program button. The Cancel button label will change to Program after selecting the Safety processor image. After clicking on the Program button, the programming will start, and it will take some time. The status of the programming process, indicating success or failure, will be displayed below.

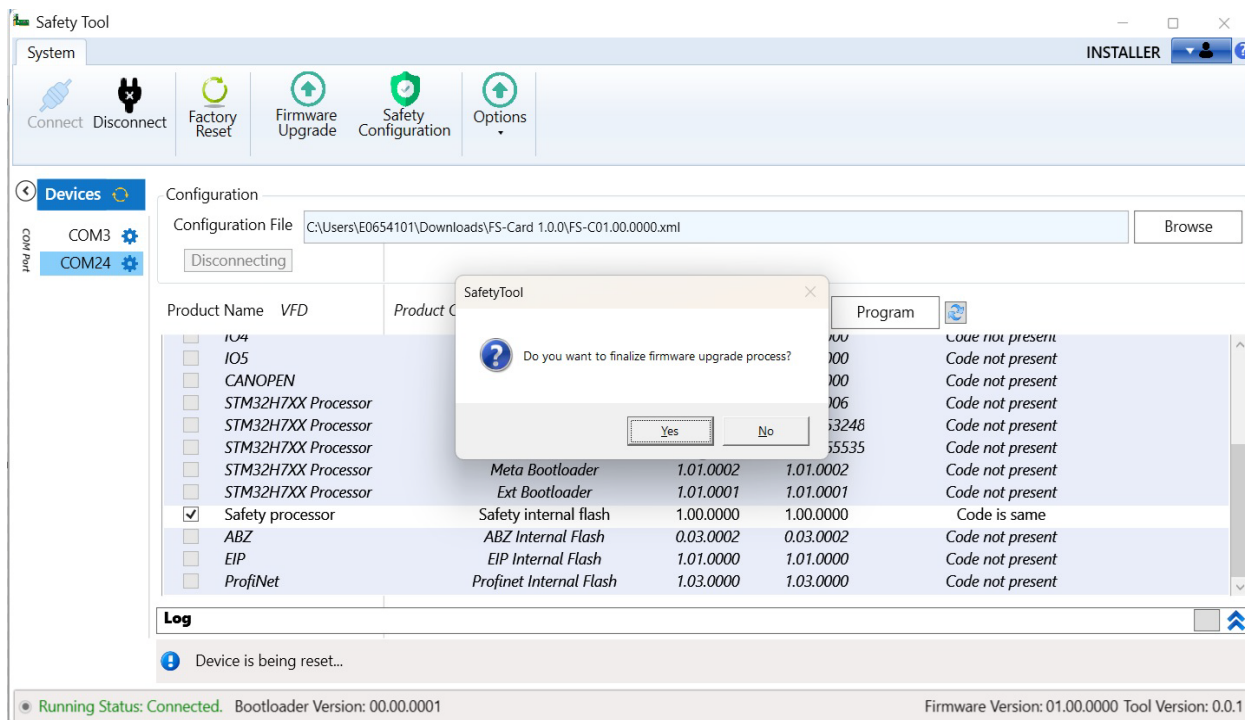

- ▶ After the successful completion of the upgrade or downgrade process, as shown in the above screenshot, the Safety Tool will ask if you want to finalize the firmware upgrade/downgrade process. In this case, press 'Yes' and then wait for a few seconds. Once you're able to press the 'Disconnect' button, press it and wait for 1 or 2 minutes, as the device takes some time to finalize the entire upgrade/downgrade process.

## 5 List of Parameters

### Basic Parameters

The Basic parameters can set the encoder pulse and configure DO.

The screenshot shows the Safety Tool software interface. The main window is titled "Safety Tool" and has a menu bar with "System" and "INSTALLER". Below the menu bar are several icons: Connect, Disconnect, Factory Reset, Firmware Upgrade, Safety Configuration, and Options. The main area is divided into three sections: "Devices", "Safety Parameters", and "Safety Configuration".

The "Safety Parameters" section lists the following parameters:

- P1: Basic Parameters
- P2: SS1 Function
- P3: SBC Function
- P4: SLS Function
- P5: SOS Function
- P6: SS2 Function
- P7: SSM Function
- P8: SDI Function
- P9: SLA Function
- P10: SSR Function
- P11: SAR Function
- P12: Monitor Function

The "Safety Configuration" section shows the following parameters and their values:

Parameter	Value	Unit	Action
P1.1 Encoder Pulse Count	1024	ppr	Set
P1.2 Max Speed	1,500.00	rpm	Set
P1.3 DO1 Mode	0: Not Used		Set
P1.4 DO2 Mode	0: Not Used		Set
P1.5 Safety Card Configuration	1: FS + SABZ Card		Set
P1.6 DO Pulse Width	0: 1 ms		Set

At the bottom of the window, there are two buttons: "Set All" and "Reset All". The status bar at the bottom indicates: "Running Status: Connected. Bootloader Version: 00.00.0001 Firmware Version: 01.00.0000 Tool Version: 0.0.1".

## 5 List of Parameters

Parameter	Parameter Number	Min	Max	Unit	Default	Note	Description
<b>Basic Parameters (P1)</b>							
Encoder Pulse Count	P1.1	1	60000	ppr	1024	–	Sets the number of pulses for motor revolution of encoder.
Max Speed	P1.2	–	–	rpm	1500.00	–	Set the maximum speed according to the specifications on the encoder. Divide the captured encoder signal. Make speed calculations more accurate
DO1 Mode	P1.3	0	15	–	0	0 = NOT USED 1 = SS1 Status 2 = SBC Status 3 = SBC test OK signal 4 = SLS Status 5 = SOS Status 6 = SS2 Status 7 = SSM safety speed indication 8 = SDI+ Status 9 = SDI- Status 10 = SLA Status 11 = SSR Status 12 = SAR Status 13 = STO Status 14 = Output High 15 = Output Low	Setting Value Signal Content 0: No Action. 1: SS1 function is activated. 2: SBC output is activated. 3: SBC test OK signal is activated. Active when the SBC feedback indicates that the SBC works correctly. 4: SLS function is activated. 5: SOS function is activated. 6: SS2 function is activated. 7: SSM function safety speed indication is activated. 8: SDI+ function is activated. 9: SDI- function is activated. 10: SLA function is activated. 11: SSR function is activated. 12: SAR function is activated. 13: FS card STO function is activated. 14: DO keeps high. 15: DO keeps low.
DO2 Mode	P1.4	0	15	–	0	0 = NOT USED 1 = SS1 Status 2 = SBC Status 3 = SBC test OK signal 4 = SLS Status 5 = SOS Status 6 = SS2 Status 7 = SSM safety speed indication 8 = SDI+ Status 9 = SDI- Status 10 = SLA Status 11 = SSR Status 12 = SAR Status 13 = STO Status 14 = Output High 15 = Output Low	Setting Value Signal Content 0: No Action. 1: SS1 function is activated. 2: SBC output is activated. 3: SBC test OK signal is activated. Active when the SBC feedback indicates that the SBC works correctly. 4: SLS function is activated. 5: SOS function is activated. 6: SS2 function is activated. 7: SSM function safety speed indication is activated. 8: SDI+ function is activated. 9: SDI- function is activated. 10: SLA function is activated. 11: SSR function is activated. 12: SAR function is activated. 13: FS card STO function is activated. 14: DO keeps high. 15: DO keeps low.

## SS1 Parameters

The SS1 (Safe Stop 1) function stops the motor safely by ramping down the motor speed, it will activate the STO function below a user-defined zero speed limit. This safety function corresponds to a controlled stop in accordance with stop category 1 of IEC 60204-1.

The screenshot displays the Safety Tool software interface. The main window is titled "Safety Tool" and includes a toolbar with icons for Connect, Disconnect, Factory Reset, Firmware Upgrade, Safety Configuration, and Options. The "Safety Configuration" section is active, showing a list of parameters for SS1. The parameters are as follows:

Parameter ID	Parameter Name	Value	Unit	Action
P2.1	SS1 Enable	0: Disabled		Set
P2.2	SS1 Source	0: Not Used		Set
P2.3	SS1 Mode	0: SS1 Time		Set
P2.4	t-delay STO@SS1	20.0	s	Set
P2.5	SS1 n=0 Limit	40.00	rpm	Set
P2.6	SS1 Acknowledgement Mode	0: Not Used		Set

At the bottom of the interface, there are "Set All" and "Reset All" buttons. The status bar at the bottom indicates "Running Status: Connected", "Bootloader Version: 00.00.0001", "Firmware Version: 01.00.0000", and "Tool Version: 0.0.1".

## 5 List of Parameters

Parameter	Parameter Number	Min	Max	Unit	Default	Note	Description																		
<b>SS1 Parameters (P2)</b>																									
SS1 Enable	P2.1	–	–	–	0	0 = Disabled 1 = Enable	This parameter allows the user to activate or deactivate the SS1 function.																		
SS1 Source	P2.2	–	–	–	0	0 = None 1 = DIN1_1 & DIN1_2 2 = DIN2_1 & DIN2_2 3 = DIN3_1 & DIN3_2 4 = DIN4_1 & DIN4_2	<p>0: No select input connected. 1: select input DI 1:1 &amp; DI 2:1 2: select input DI 1:2 &amp; DI 2:2 3: select input DI 1:3 &amp; DI 2:3 4: select input DI 1:4 &amp; DI 2:4</p> <p>This parameter sets the digital input that is connected to the input of the SS1 function. The truth table is as follows:</p> <table border="1"> <thead> <tr> <th>Options in "Note"</th> <th>FS_MCU1</th> <th>FS_MCU2</th> </tr> </thead> <tbody> <tr> <td>0</td> <td>None</td> <td>None</td> </tr> <tr> <td>1</td> <td>Select DIN1_1</td> <td>Select DIN1_2</td> </tr> <tr> <td>2</td> <td>Select DIN2_1</td> <td>Select DIN2_2</td> </tr> <tr> <td>3</td> <td>Select DIN3_1</td> <td>Select DIN3_2</td> </tr> <tr> <td>4</td> <td>Select DIN4_1</td> <td>Select DIN4_2</td> </tr> </tbody> </table>	Options in "Note"	FS_MCU1	FS_MCU2	0	None	None	1	Select DIN1_1	Select DIN1_2	2	Select DIN2_1	Select DIN2_2	3	Select DIN3_1	Select DIN3_2	4	Select DIN4_1	Select DIN4_2
Options in "Note"	FS_MCU1	FS_MCU2																							
0	None	None																							
1	Select DIN1_1	Select DIN1_2																							
2	Select DIN2_1	Select DIN2_2																							
3	Select DIN3_1	Select DIN3_2																							
4	Select DIN4_1	Select DIN4_2																							
SS1 Mode	P2.3	–	–	–	0	0 = SS1-t 1 = SS1-r	Sets the SS1 type, that is, the method used for the SS1 monitoring. SS1-t is Time monitoring. SS1-r is Ramp monitoring.																		
t-delay STO@SS1	P2.4	0	3600.0	s	20.0	–	Sets the safe delay after which the FS card activates the STO function after the SS1 request. This parameter is relevant only if time monitoring is used and the motor speed does not follow the ramp. See parameter SS1 type.																		
SS1 n = 0 Limit	P2.5	0	6000.0	rpm	40.00	–	User-defined Zero Speed. Speed limit for activating the drive STO function. The safety function is completed and the SS1 completed indication goes on.																		
SS1 Acknowledgement Mode	P2.6	0	5	–	0	0 = None 1 = DIN1_1 & DIN1_2 2 = DIN2_1 & DIN2_2 3 = DIN3_1 & DIN3_2 4 = DIN4_1 & DIN4_2 5 = Automatic	<p>Safety functions acknowledgement methods.</p> <p>0: No select Acknowledge. 1: select dual channel DI1 to manual acknowledge 2: select dual channel DI2 to manual acknowledge 3: select dual channel DI3 to manual acknowledge 4: select dual channel DI4 to manual acknowledge 5: Automatic acknowledge</p>																		

## SBC Parameter

The SBC (Safe Brake Control) function provides a safe output signal to control an external safe brake device via force guided safety relay.

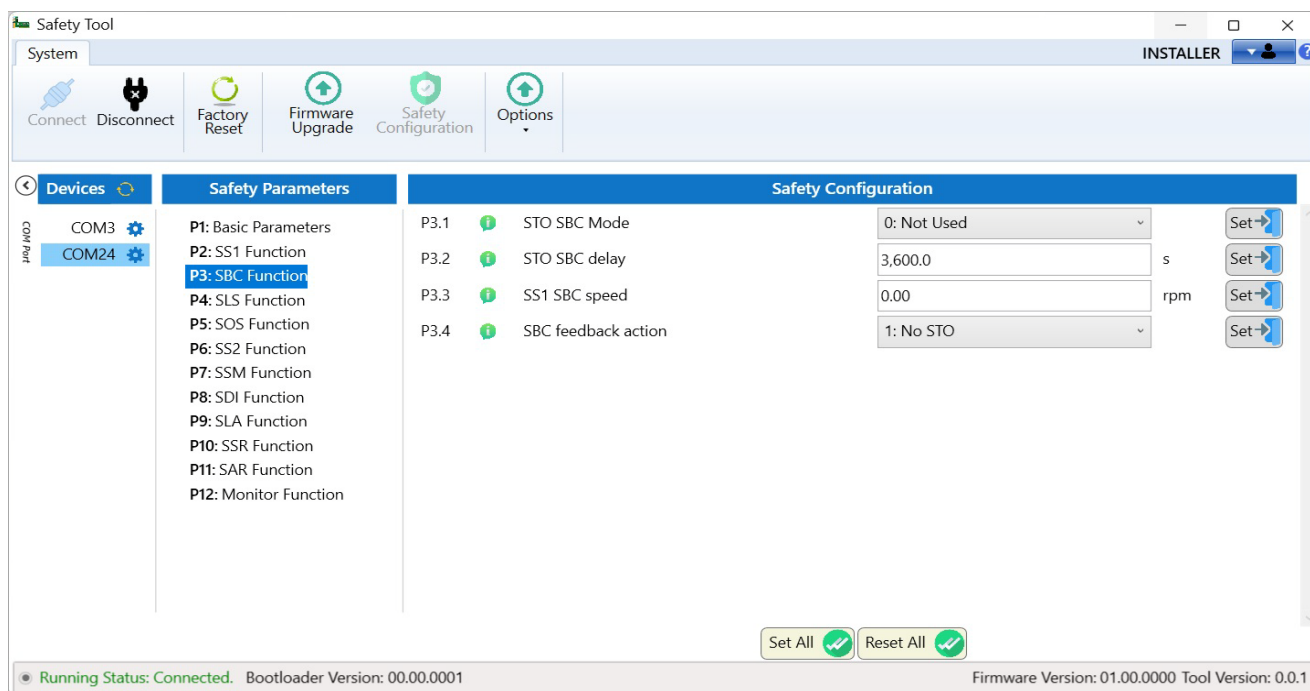

Parameter	Parameter Number	Min	Max	Unit	Default	Note	Description
<b>SBC Parameters (P3)</b>							
STO SBC Mode	P3.1	–	–	–	0	0 = None 1 = Delayed brake 2 = Speed limit	Sets how the mechanical brake (SBC) is used together with the STO function. 0: No brake 1: Time controlled brake. Parameter STO SBC delay defines the delay. 2: The brake is activated below a user-defined speed limit.
STO SBC delay	P3.2	-5.0	3600.0	s	20.0	–	Sets the time after which the FS card activates the SBC after it has activated the drive STO function. A negative value means that the FS card activates the SBC before the drive STO function. If the value is 0 s, the FS card activates the drive STO and SBC functions at the same time.
SS1 SBC speed	P3.3	0.00	1000.00	rpm	0.00	–	This parameter is to allow the user to set the speed limit of the FS card to activate the brake (SBC) while ramping SS1 function. The STO SBC usage is set up to the Speed limit value defined in this parameter. If the value is 0.0 rpm, this feature is not in use.
SBC feedback action	P3.4	–	–	–	1	0 = STO 1 = No STO	Sets the action that the FS card takes when there is a problem with the SBC feedback. 0: The FS card activates the drive STO function. 1: The FS card sends a warning to the drive.

## 5 List of Parameters

### SLS Parameters

The SLS (Safely Limited Speed) prevents the motor from exceeding user-defined speed limits. The drive limits the motor speed so that it stays between the SLS speed limits.

The screenshot displays the Safety Tool software interface. At the top, there is a 'System' menu with options: Connect, Disconnect, Factory Reset, Firmware Upgrade, Safety Configuration, and Options. The main area is divided into three sections: 'Devices' (showing COM3 and COM24), 'Safety Parameters' (listing P1 through P12), and 'Safety Configuration' (showing P4.1 through P4.7). The 'Safety Configuration' section is currently selected, showing the following parameters:

Parameter ID	Parameter Name	Value	Unit	Action
P4.1	SLS Enable	0: Disabled		Set →
P4.2	SLS Mode	0: SLS Time		Set →
P4.3	SLS-t delay	20.0	s	Set →
P4.4	SLS Source	0: Not Used		Set →
P4.5	SLS trip limit	1,000.00	rpm	Set →
P4.6	SLS limit	500.00	rpm	Set →
P4.7	SLS Acknowledgement Mode	0: Not Used		Set →

At the bottom of the interface, there are 'Set All' and 'Reset All' buttons. The status bar at the very bottom indicates: 'Running Status: Connected. Bootloader Version: 00.00.0001 Firmware Version: 01.00.0000 Tool Version: 0.0.1'.

Parameter	Parameter Number	Min	Max	Unit	Default	Note	Description																		
<b>SLS Parameters (P4)</b>																									
SLS Enable	P4.1	–	–	–	0	0 = Disabled 1 = Enable	0: Deactivates the SLS function 1: Activates the SLS function Activates or deactivates the SLS function.																		
SLS limit	P4.2	0	30000.00	rpm	500.0	–	Sets the SLS positive speed limit for the drive.																		
SLS Mode	P4.3	–	–	–	0	0 = Ramp 1 = Time	0: Ramp monitoring. 1: Time monitoring Sets the monitoring method that is used in SLS activation.																		
SLS-t delay	P4.4	0	3600.0	s	20.0	–	Sets the security delay after which the FS card activates the SLS monitoring after the SLS request. This parameter is relevant only if time monitoring is used.																		
SLS Source	P4.5	–	–	–	0	0 = None 1 = DIN1_1 & DIN1_2 2 = DIN2_1 & DIN2_2 3 = DIN3_1 & DIN3_2 4 = DIN4_1 & DIN4_2	0: No select input connected. 1: select input DI 1:1 & DI 2:1 2: select input DI 1:2 & DI 2:2 3: select input DI 1:3 & DI 2:3 4: select input DI 1:4 & DI 2:4 This parameter the digital input that is connected to the primary input of the SLS function with limits. The truth table is as follows: <table border="1" data-bbox="1077 1048 1452 1299"> <thead> <tr> <th>Options</th> <th>FS_MCU1</th> <th>FS_MCU2</th> </tr> </thead> <tbody> <tr> <td>0</td> <td>No select</td> <td>No select</td> </tr> <tr> <td>1</td> <td>Select DIN1_1</td> <td>Select DIN1_2</td> </tr> <tr> <td>2</td> <td>Select DIN2_1</td> <td>Select DIN2_2</td> </tr> <tr> <td>3</td> <td>Select DIN3_1</td> <td>Select DIN3_2</td> </tr> <tr> <td>4</td> <td>Select DIN4_1</td> <td>Select DIN4_2</td> </tr> </tbody> </table>	Options	FS_MCU1	FS_MCU2	0	No select	No select	1	Select DIN1_1	Select DIN1_2	2	Select DIN2_1	Select DIN2_2	3	Select DIN3_1	Select DIN3_2	4	Select DIN4_1	Select DIN4_2
Options	FS_MCU1	FS_MCU2																							
0	No select	No select																							
1	Select DIN1_1	Select DIN1_2																							
2	Select DIN2_1	Select DIN2_2																							
3	Select DIN3_1	Select DIN3_2																							
4	Select DIN4_1	Select DIN4_2																							
SLS trip limit	P4.6	0	30000.00	rpm	1000.00	–	Sets the SLS positive speed limit that trips the drive.																		
SLS Acknowledgement Mode	P4.7	0	5	–	0	0 = None 1 = DIN1_1 & DIN1_2 2 = DIN2_1 & DIN2_2 3 = DIN3_1 & DIN3_2 4 = DIN4_1 & DIN4_2 5 = Automatic	Safety functions acknowledgement methods. 0: No select Acknowledge. 1: select dual channel DI1 to manual acknowledge 2: select dual channel DI2 to manual acknowledge 3: select dual channel DI3 to manual acknowledge 4: select dual channel DI4 to manual acknowledge 5: Automatic acknowledge																		

### SOS Parameters

The SOS (Safe Operating Stop) function prevents the motor from deviating more than a defined amount from the stopped position. The drive provides energy to the motor to enable it to resist external forces.

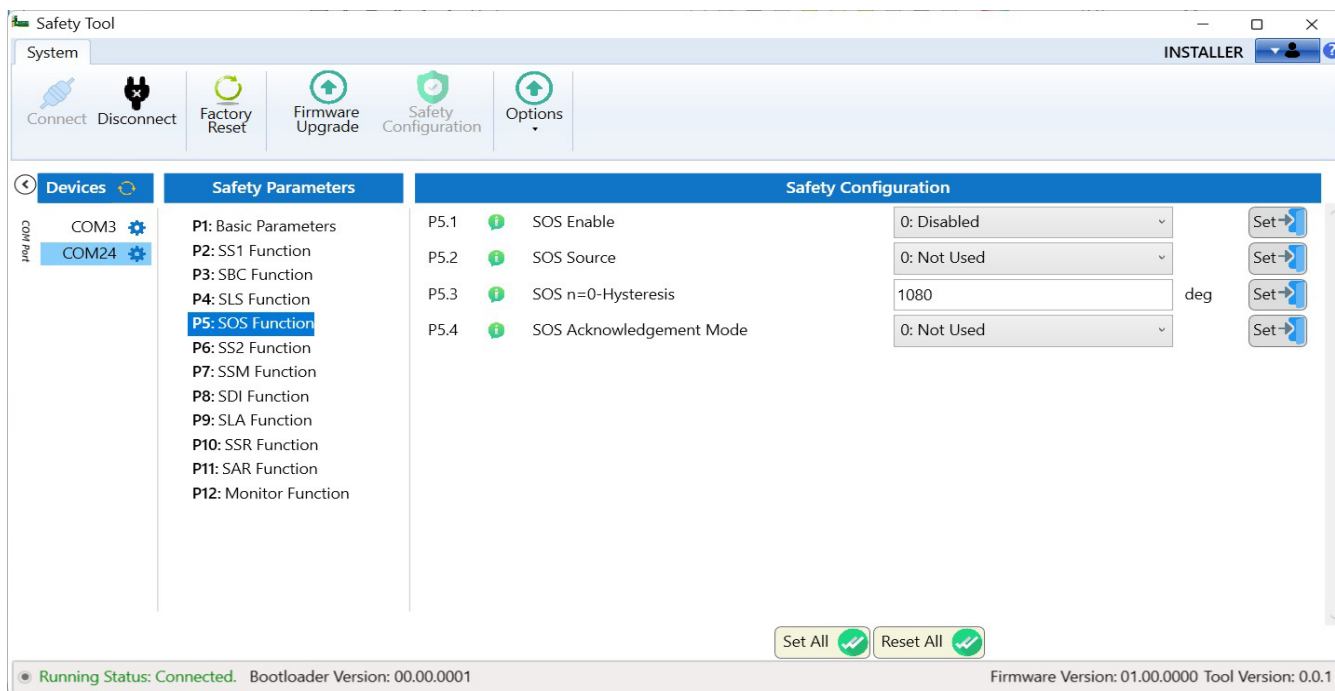

Parameter	Parameter Number	Min	Max	Unit	Default	Note	Description																					
<b>SOS Parameters (P5)</b>																												
SOS Enable	P5.1	–	–	–	0	0 = Disabled 1 = Enable	This parameter allows the user to activate or deactivate the SOS function.																					
SOS Source	P5.2	–	–	–	0	0 = None 1 = DIN1_1 & DIN1_2 2 = DIN2_1 & DIN2_2 3 = DIN3_1 & DIN3_2 4 = DIN4_1 & DIN4_2 5 = Always on	0: No select input connected. 1: select input DI 1:1 & DI 2:1 2: select input DI 1:2 & DI 2:2 3: select input DI 1:3 & DI 2:3 4: select input DI 1:4 & DI 2:4 5: The SOS function is always on. This parameter sets the digital input that is connected to the input of the SOS function. The truth table is as follows: <table border="1" data-bbox="1075 763 1449 1055"> <thead> <tr> <th>Options</th> <th>FS_MCU1</th> <th>FS_MCU2</th> </tr> </thead> <tbody> <tr> <td>0</td> <td>No select</td> <td>No select</td> </tr> <tr> <td>1</td> <td>Select DIN1_1</td> <td>Select DIN1_2</td> </tr> <tr> <td>2</td> <td>Select DIN2_1</td> <td>Select DIN2_2</td> </tr> <tr> <td>3</td> <td>Select DIN3_1</td> <td>Select DIN3_2</td> </tr> <tr> <td>4</td> <td>Select DIN4_1</td> <td>Select DIN4_2</td> </tr> <tr> <td>5</td> <td>Always on</td> <td>Always on</td> </tr> </tbody> </table>	Options	FS_MCU1	FS_MCU2	0	No select	No select	1	Select DIN1_1	Select DIN1_2	2	Select DIN2_1	Select DIN2_2	3	Select DIN3_1	Select DIN3_2	4	Select DIN4_1	Select DIN4_2	5	Always on	Always on
Options	FS_MCU1	FS_MCU2																										
0	No select	No select																										
1	Select DIN1_1	Select DIN1_2																										
2	Select DIN2_1	Select DIN2_2																										
3	Select DIN3_1	Select DIN3_2																										
4	Select DIN4_1	Select DIN4_2																										
5	Always on	Always on																										
SOS n = 0 - Hysteresis	P5.3	0	3600000	deg	1080	–	Sets the position tolerance for the SOS function. The deviation of the position must within in this value. Otherwise, will trigger STO function.																					
SOS Acknowledgement Mode	P5.4	0	5	–	0	0 = None 1 = DIN1_1 & DIN1_2 2 = DIN2_1 & DIN2_2 3 = DIN3_1 & DIN3_2 4 = DIN4_1 & DIN4_2 5 = Automatic	Safety functions acknowledgement methods. 0: No select Acknowledge. 1: select dual channel DI1 to manual acknowledge 2: select dual channel DI2 to manual acknowledge 3: select dual channel DI3 to manual acknowledge 4: select dual channel DI4 to manual acknowledge 5: Automatic acknowledge																					

## 5 List of Parameters

### SS2 Parameters

The SS2 (Safe Stop 2) function monitors the motor deceleration rate within set limits during motor stopping and initiates the Safe Operating Stop (SOS) function when the motor speed is below the specified limit. This safety function corresponds to a controlled stop in accordance with stop category 2 of IEC 60204-1.

The screenshot displays the Safety Tool software interface. The top menu bar includes 'System' and 'INSTALLER'. Below the menu bar are icons for 'Connect', 'Disconnect', 'Factory Reset', 'Firmware Upgrade', 'Safety Configuration', and 'Options'. The main interface is divided into three sections: 'Devices', 'Safety Parameters', and 'Safety Configuration'. The 'Safety Parameters' section lists parameters P1 through P12, with 'P6: SS2 Function' highlighted. The 'Safety Configuration' section shows the configuration for P6.1 through P6.6, including values and units, and 'Set' buttons for each parameter. At the bottom, there are 'Set All' and 'Reset All' buttons, and a status bar showing 'Running Status: Connected', 'Bootloader Version: 00.00.0001', 'Firmware Version: 01.00.0000', and 'Tool Version: 0.0.1'.

Parameter ID	Parameter Name	Value	Unit
P6.1	SS2 Enable	0: Disabled	
P6.2	SS2 Source	0: Not Used	
P6.3	SS2 Mode	0: SS2 Time	
P6.4	t-delay STO@SS2	20.0	s
P6.5	SS2 n=0 Limit	40.00	rpm
P6.6	SS2 Acknowledgement Mode	0: Not Used	

Parameter	Parameter Number	Min	Max	Unit	Default	Note	Description																		
<b>SS2 Parameters (P6)</b>																									
SS2 Enable	P6.1	–	–	–	0	0 = Disabled 1 = Enable	This parameter allows the user to activate or deactivate the SS2 function.																		
SS2 Source	P6.2	–	–	–	0	0 = None 1 = DIN1_1 & DIN1_2 2 = DIN2_1 & DIN2_2 3 = DIN3_1 & DIN3_2 4 = DIN4_1 & DIN4_2	0: No select input connected. 1: select input DI 1:1 & DI 2:1 2: select input DI 1:2 & DI 2:2 3: select input DI 1:3 & DI 2:3 4: select input DI 1:4 & DI 2:4 This parameter sets the digital input that is connected to the input of the SS2 function. The truth table is as follows: <table border="1" data-bbox="1077 734 1452 987"> <thead> <tr> <th>Options</th> <th>FS_MCU1</th> <th>FS_MCU2</th> </tr> </thead> <tbody> <tr> <td>0</td> <td>No select</td> <td>No select</td> </tr> <tr> <td>1</td> <td>Select DIN1_1</td> <td>Select DIN1_2</td> </tr> <tr> <td>2</td> <td>Select DIN2_1</td> <td>Select DIN2_2</td> </tr> <tr> <td>3</td> <td>Select DIN3_1</td> <td>Select DIN3_2</td> </tr> <tr> <td>4</td> <td>Select DIN4_1</td> <td>Select DIN4_2</td> </tr> </tbody> </table>	Options	FS_MCU1	FS_MCU2	0	No select	No select	1	Select DIN1_1	Select DIN1_2	2	Select DIN2_1	Select DIN2_2	3	Select DIN3_1	Select DIN3_2	4	Select DIN4_1	Select DIN4_2
Options	FS_MCU1	FS_MCU2																							
0	No select	No select																							
1	Select DIN1_1	Select DIN1_2																							
2	Select DIN2_1	Select DIN2_2																							
3	Select DIN3_1	Select DIN3_2																							
4	Select DIN4_1	Select DIN4_2																							
SS2 Mode	P6.3	–	–	–	0	0 = SS2-r 1 = SS2-t	Sets the SS2 type, that is, the method used for the SS2 monitoring. SS2-r is Ramp monitoring. SS2-t is Time monitoring.																		
t-delay STO@SS2	P6.4	0	3600.0	s	20.0	–	Sets the security delay after which the FS card activates the STO function after the SS2 request. This parameter is relevant only if time monitoring is used and the motor speed does not follow the ramp. See parameter SS2 type.																		
SS2 n = 0 Limit	P6.5	0	600.00	rpm	40.00	–	Speed limit for activating the drive STO function. The safety function is completed and the SS2 completed indication goes on. The acknowledgment becomes allowed.																		
SS2 Acknowl- edgement Mode	P6.6	0	5	–	0	0 = None 1 = DIN1_1 & DIN1_2 2 = DIN2_1 & DIN2_2 3 = DIN3_1 & DIN3_2 4 = DIN4_1 & DIN4_2 5 = Automatic	Safety functions acknowledgement methods. 0: No select Acknowledge. 1: select dual channel DI1 to manual acknowledge 2: select dual channel DI2 to manual acknowledge 3: select dual channel DI3 to manual acknowledge 4: select dual channel DI4 to manual acknowledge 5: Automatic acknowledge																		

## 5 List of Parameters

### SSM Parameters

The SSM (Safe Speed Monitor) function provides a safe output signal to indicate whether the motor speed is below a specified limit. FS card monitors motor speed and output a safe DO signal to indicate whether the motor speed is below a specified limit.

The screenshot displays the Safety Tool software interface. At the top, there is a 'System' menu with options: Connect, Disconnect, Factory Reset, Firmware Upgrade, Safety Configuration, and Options. Below this is a navigation pane with 'Devices' and 'Safety Parameters' selected. The 'Safety Parameters' section lists P1 through P12, with P7: SSM Function highlighted. The 'Safety Configuration' section shows four parameters: P7.1 SSM Enable (0: Disabled), P7.2 SSM Source (0: Not Used), P7.3 SSM Limit (1,000.00 rpm), and P7.4 SSM Hysteresis (30.00 rpm). Each parameter has a 'Set' button. At the bottom, there are 'Set All' and 'Reset All' buttons. The status bar at the bottom indicates 'Running Status: Connected', 'Bootloader Version: 00.00.0001', 'Firmware Version: 01.00.0000', and 'Tool Version: 0.0.1'.

Parameter ID	Parameter Name	Value	Unit
P7.1	SSM Enable	0: Disabled	
P7.2	SSM Source	0: Not Used	
P7.3	SSM Limit	1,000.00	rpm
P7.4	SSM Hysteresis	30.00	rpm

Parameter	Parameter Number	Min	Max	Unit	Default	Note	Description																					
<b>SSM Parameters (P7)</b>																												
SSM Enable	P7.1	–	–	–	0	0 = Disabled 1 = Enable	This parameter allows the user to activate or deactivate the SSM function.																					
SSM Source	P7.2	–	–	–	0	0 = None 1 = DIN1_1 & DIN1_2 2 = DIN2_1 & DIN2_2 3 = DIN3_1 & DIN3_2 4 = DIN4_1 & DIN4_2 5 = Always on	<p>0: No select input connected. 1: select input DI 1:1 &amp; DI 2:1 2: select input DI 1:2 &amp; DI 2:2 3: select input DI 1:3 &amp; DI 2:3 4: select input DI 1:4 &amp; DI 2:4 5: The SSM function is always on.</p> <p>This parameter sets the digital input that is connected to the input of the SSM function. The truth table is as follows:</p> <table border="1"> <thead> <tr> <th>Options</th> <th>FS_MCU1</th> <th>FS_MCU2</th> </tr> </thead> <tbody> <tr> <td>0</td> <td>No select</td> <td>No select</td> </tr> <tr> <td>1</td> <td>Select DIN1_1</td> <td>Select DIN1_2</td> </tr> <tr> <td>2</td> <td>Select DIN2_1</td> <td>Select DIN2_2</td> </tr> <tr> <td>3</td> <td>Select DIN3_1</td> <td>Select DIN3_2</td> </tr> <tr> <td>4</td> <td>Select DIN4_1</td> <td>Select DIN4_2</td> </tr> <tr> <td>5</td> <td>Always on</td> <td>Always on</td> </tr> </tbody> </table>	Options	FS_MCU1	FS_MCU2	0	No select	No select	1	Select DIN1_1	Select DIN1_2	2	Select DIN2_1	Select DIN2_2	3	Select DIN3_1	Select DIN3_2	4	Select DIN4_1	Select DIN4_2	5	Always on	Always on
Options	FS_MCU1	FS_MCU2																										
0	No select	No select																										
1	Select DIN1_1	Select DIN1_2																										
2	Select DIN2_1	Select DIN2_2																										
3	Select DIN3_1	Select DIN3_2																										
4	Select DIN4_1	Select DIN4_2																										
5	Always on	Always on																										
SSM Limit	P7.3	0.0	30000.00	rpm	0.00	–	Sets the speed limit for the SSM function.																					
SSM Hysteresis	P7.4	0.0	30000.00	rpm	0.00	–	The parameterization hysteresis ensures that the SSM output signal does not jump between the values 0 and 1 in the limit range.																					

## 5 List of Parameters

### SDI Parameters

The SDI (Safe Direction) function prevents the motor shaft from moving more than a defined amount in the unintended direction.

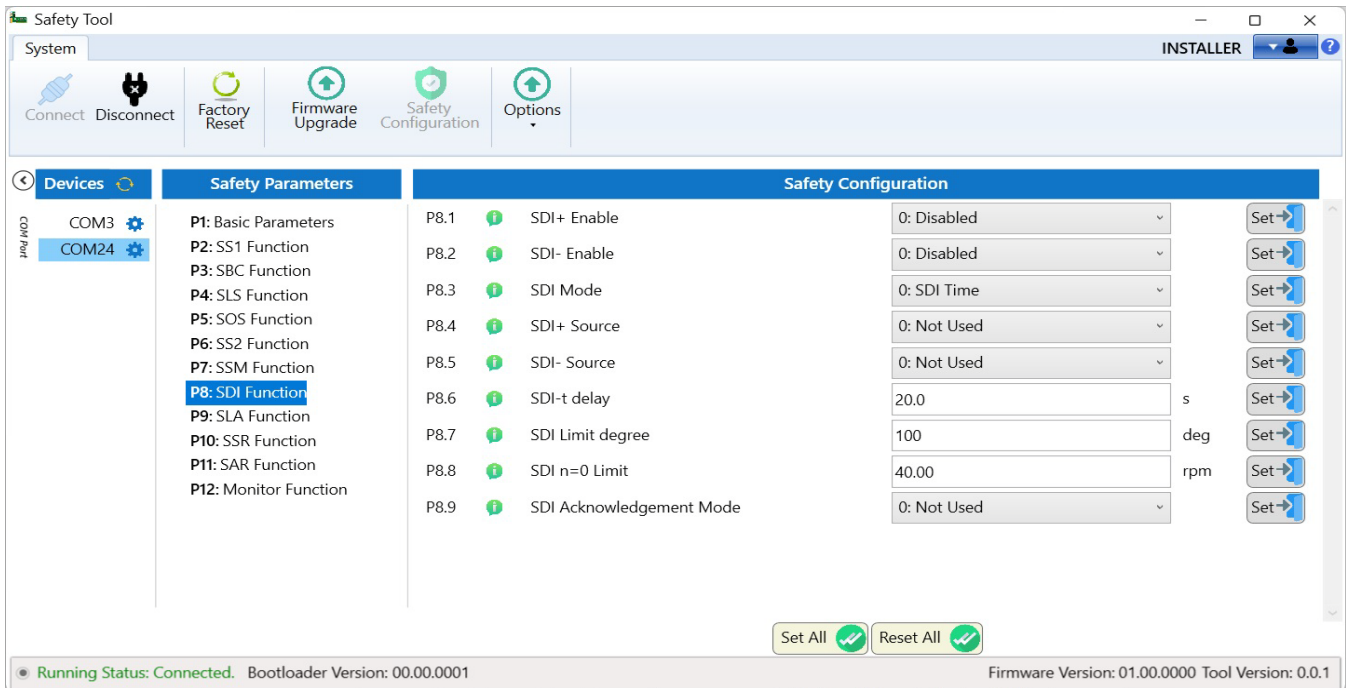

Parameter	Parameter Number	Min	Max	Unit	Default	Note	Description
<b>SDI Parameters (P8)</b>							
SDI+ Enable	P8.1	–	–	–	0	0 = Disabled 1 = Enable	This parameter allows the user to activate or deactivate the SDI positive activity function.
SDI- Enable	P8.2	–	–	–	0	0 = Disabled 1 = Enable	This parameter allows the user to activate or deactivates the SDI negative activity function.
SDI Mode	P8.3	–	–	–	0	0 = SDI-r 1 = SDI-t	0: Ramp monitoring. 1: Time monitoring Sets the monitoring method that is used in SDI activation.
SDI-t delay	P8.4	0	3600.0	s	20.0	–	Sets the delay for starting SDI monitoring. This parameter is relevant only when parameter SDI activation monitoring method is set to Time.
SDI Limit degree	P8.5	0	3600000	deg	100	–	Sets the position tolerance for the SDI function. The position of the motor axle cannot move into the forbidden direction more than defined with this parameter. Note: This is the absolute value. The same value is used in both positive and negative directions.
SDI n=0 Limit	P8.6	0	600.00	rpm	40.00	–	Speed limit for activating the drive STO function. The safety function is completed, and the SDI completed indication goes on. The acknowledgment becomes allowed.

Parameter	Parameter Number	Min	Max	Unit	Default	Note	Description																					
SDI+ Source	P8.7	–	–	–	0	0 = None 1 = DIN1_1 & DIN1_2 2 = DIN2_1 & DIN2_2 3 = DIN3_1 & DIN3_2 4 = DIN4_1 & DIN4_2 5 = Always on	0: No select input connected. 1: select input DI 1:1 & DI 2:1 2: select input DI 1:2 & DI 2:2 3: select input DI 1:3 & DI 2:3 4: select input DI 1:4 & DI 2:4 5: The SDI positive is always on. This parameter sets the digital input that is connected to the input of the SDI positive function. The truth table is as follows: <table border="1"> <thead> <tr> <th>Options</th> <th>FS_MCU1</th> <th>FS_MCU2</th> </tr> </thead> <tbody> <tr> <td>0</td> <td>No select</td> <td>No select</td> </tr> <tr> <td>1</td> <td>Select DIN1_1</td> <td>Select DIN1_2</td> </tr> <tr> <td>2</td> <td>Select DIN2_1</td> <td>Select DIN2_2</td> </tr> <tr> <td>3</td> <td>Select DIN3_1</td> <td>Select DIN3_2</td> </tr> <tr> <td>4</td> <td>Select DIN4_1</td> <td>Select DIN4_2</td> </tr> <tr> <td>5</td> <td>Always on</td> <td>Always on</td> </tr> </tbody> </table>	Options	FS_MCU1	FS_MCU2	0	No select	No select	1	Select DIN1_1	Select DIN1_2	2	Select DIN2_1	Select DIN2_2	3	Select DIN3_1	Select DIN3_2	4	Select DIN4_1	Select DIN4_2	5	Always on	Always on
Options	FS_MCU1	FS_MCU2																										
0	No select	No select																										
1	Select DIN1_1	Select DIN1_2																										
2	Select DIN2_1	Select DIN2_2																										
3	Select DIN3_1	Select DIN3_2																										
4	Select DIN4_1	Select DIN4_2																										
5	Always on	Always on																										
SDI- Source	P8.8	–	–	–	0	0 = None 1 = DIN1_1 & DIN1_2 2 = DIN2_1 & DIN2_2 3 = DIN3_1 & DIN3_2 4 = DIN4_1 & DIN4_2 5 = Always on	0: No select input connected. 1: select input DI 1:1 & DI 2:1 2: select input DI 1:2 & DI 2:2 3: select input DI 1:3 & DI 2:3 4: select input DI 1:4 & DI 2:4 5: The SDI negative is always on. This parameter sets the digital input that is connected to the input of the SDI negative function. The truth table is as follows: <table border="1"> <thead> <tr> <th>Options</th> <th>FS_MCU1</th> <th>FS_MCU2</th> </tr> </thead> <tbody> <tr> <td>0</td> <td>No select</td> <td>No select</td> </tr> <tr> <td>1</td> <td>Select DIN1_1</td> <td>Select DIN1_2</td> </tr> <tr> <td>2</td> <td>Select DIN2_1</td> <td>Select DIN2_2</td> </tr> <tr> <td>3</td> <td>Select DIN3_1</td> <td>Select DIN3_2</td> </tr> <tr> <td>4</td> <td>Select DIN4_1</td> <td>Select DIN4_2</td> </tr> <tr> <td>5</td> <td>Always on</td> <td>Always on</td> </tr> </tbody> </table>	Options	FS_MCU1	FS_MCU2	0	No select	No select	1	Select DIN1_1	Select DIN1_2	2	Select DIN2_1	Select DIN2_2	3	Select DIN3_1	Select DIN3_2	4	Select DIN4_1	Select DIN4_2	5	Always on	Always on
Options	FS_MCU1	FS_MCU2																										
0	No select	No select																										
1	Select DIN1_1	Select DIN1_2																										
2	Select DIN2_1	Select DIN2_2																										
3	Select DIN3_1	Select DIN3_2																										
4	Select DIN4_1	Select DIN4_2																										
5	Always on	Always on																										
SDI Acknowledgement Mode	P8.9	0	5	–	0	0 = None 1 = DIN1_1 & DIN1_2 2 = DIN2_1 & DIN2_2 3 = DIN3_1 & DIN3_2 4 = DIN4_1 & DIN4_2 5 = Automatic	Safety functions acknowledgement methods. 0: No select Acknowledge. 1: select dual channel DI1 to manual acknowledge 2: select dual channel DI2 to manual acknowledge 3: select dual channel DI3 to manual acknowledge 4: select dual channel DI4 to manual acknowledge 5: Automatic acknowledge																					

## 5 List of Parameters

### SLA Parameters

The SLA (Safety limit acceleration) function prevents the motor from exceeding the specified acceleration or deceleration limit. FS card monitors motor acceleration/deceleration and activates STO if the motor acceleration exceeds the specified limit.

The screenshot displays the Safety Tool software interface. The top navigation bar includes buttons for Connect, Disconnect, Factory Reset, Firmware Upgrade, Safety Configuration, and Options. The main window is divided into three sections: Devices, Safety Parameters, and Safety Configuration. The Safety Parameters section lists various functions, with P9: SLA Function highlighted. The Safety Configuration section shows a list of parameters (P9.1 to P9.9) with their current values and units, and a 'Set' button for each. The status bar at the bottom indicates 'Running Status: Connected', 'Bootloader Version: 00.00.0001', 'Firmware Version: 01.00.0000', and 'Tool Version: 0.0.1'.

Parameter ID	Parameter Name	Value	Unit
P9.1	SLA Enable	0: Disabled	
P9.2	SLA Source	0: Not Used	
P9.3	SLA t-delay	20.0	s
P9.4	SLA+ trip limit	35.00	rpm/s
P9.5	SLA+ limit	5.00	rpm/s
P9.6	SLA- trip limit	-30.00	rpm/s
P9.7	SLA- limit	-5.00	rpm/s
P9.8	SLA delta-t	1,000.0	ms
P9.9	SLA Acknowledgement Mode	0: Not Used	

Parameter	Parameter Number	Min	Max	Unit	Default	Note	Description																					
<b>SLA Parameters (P9)</b>																												
SLA Enable	P9.1	–	–	–	0	0 = Disabled 1 = Enable	This parameter allows the user to activate or deactivate the SLA function.																					
SLA Source	P9.2	–	–	–	0	0 = None 1 = DIN1_1 & DIN1_2 2 = DIN2_1 & DIN2_2 3 = DIN3_1 & DIN3_2 4 = DIN4_1 & DIN4_2 5 = Always on	0: No select input connected. 1: select input DI 1:1 & DI 2:1 2: select input DI 1:2 & DI 2:2 3: select input DI 1:3 & DI 2:3 4: select input DI 1:4 & DI 2:4 5: The SAR function is always on. This parameter sets the digital input that is connected to the input of the SLA function. The truth table is as follows: <table border="1" data-bbox="1077 757 1449 1055"> <thead> <tr> <th>Options</th> <th>FS_MCU1</th> <th>FS_MCU2</th> </tr> </thead> <tbody> <tr> <td>0</td> <td>No select</td> <td>No select</td> </tr> <tr> <td>1</td> <td>Select DIN1_1</td> <td>Select DIN1_2</td> </tr> <tr> <td>2</td> <td>Select DIN2_1</td> <td>Select DIN2_2</td> </tr> <tr> <td>3</td> <td>Select DIN3_1</td> <td>Select DIN3_2</td> </tr> <tr> <td>4</td> <td>Select DIN4_1</td> <td>Select DIN4_2</td> </tr> <tr> <td>5</td> <td>Always on</td> <td>Always on</td> </tr> </tbody> </table>	Options	FS_MCU1	FS_MCU2	0	No select	No select	1	Select DIN1_1	Select DIN1_2	2	Select DIN2_1	Select DIN2_2	3	Select DIN3_1	Select DIN3_2	4	Select DIN4_1	Select DIN4_2	5	Always on	Always on
Options	FS_MCU1	FS_MCU2																										
0	No select	No select																										
1	Select DIN1_1	Select DIN1_2																										
2	Select DIN2_1	Select DIN2_2																										
3	Select DIN3_1	Select DIN3_2																										
4	Select DIN4_1	Select DIN4_2																										
5	Always on	Always on																										
SLA t-delay	P9.3	0	3600.0	s	20.0	–	Sets the security delay after which the FS card activates the SLA monitoring after the SLA request.																					
SLA+ trip limit	P9.4	0	60000.0	rpm/s	30.00	–	Sets the SLA positive safe acceleration limit that trips the drive. Requirement: SLA+ trip limit > SLA+ limit																					
SLA+ limit	P9.5	0	60000.0	rpm/s	5.00	–	Sets the SLA positive safe acceleration limit for the drive.																					
SLA- trip limit	P9.6	60000.0	0	rpm/s	-30.00	–	Sets the SLA negative safe acceleration limit that trips the drive. Requirement: SLA- trip limit < SLA- limit																					
SLA- limit	P9.7	60000.00	0	rpm/s	-5.00	–	Sets the SLA negative safe acceleration limit for the drive.																					
SLA delta-t	P9.8	1.0	10000.0	1000.0	–	–	Set the time to calculate the change of acceleration.																					
SLA Acknowledgement Mode	P9.9	0	5	–	0	0 = None 1 = DIN1_1 & DIN1_2 2 = DIN2_1 & DIN2_2 3 = DIN3_1 & DIN3_2 4 = DIN4_1 & DIN4_2 5 = Automatic	Safety functions acknowledgement methods. 0: No select Acknowledge. 1: select dual channel DI1 to manual acknowledge 2: select dual channel DI2 to manual acknowledge 3: select dual channel DI3 to manual acknowledge 4: select dual channel DI4 to manual acknowledge 5: Automatic acknowledge																					

### SSR Parameter

The SSR (Safe Speed Range) function keeps the motor speed within specified limits. FS card monitors motor speed range and activates STO if the motor speed exceeds the specified limits.

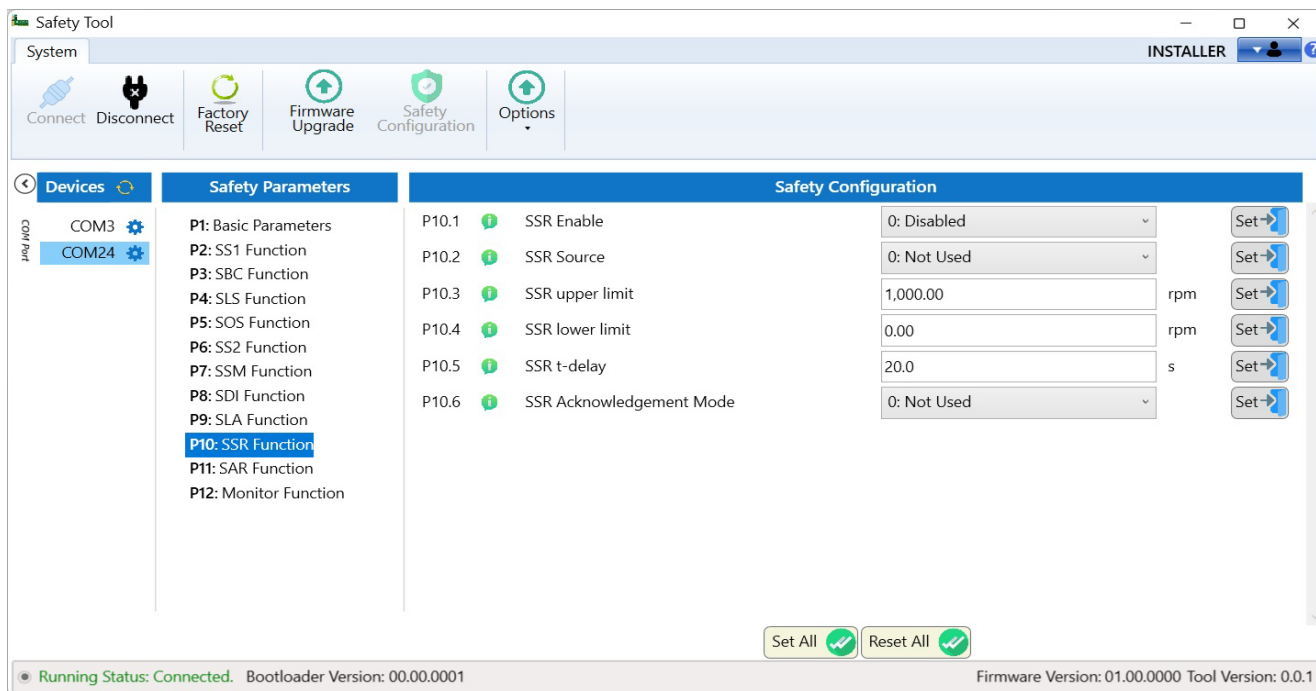

Parameter	Parameter Number	Min	Max	Unit	Default	Note	Description																					
<b>SSR Parameters (P10)</b>																												
SSR Enable	P10.1	–	–	–	0	0 = Disabled 1 = Enable	This parameter allows the user to activate or deactivate the SSR function.																					
SSR Source	P10.2	–	–	–	0	0 = None 1 = DIN1_1 & DIN1_2 2 = DIN2_1 & DIN2_2 3 = DIN3_1 & DIN3_2 4 = DIN4_1 & DIN4_2 5 = Always on	<p>0: No select input connected. 1: select input DI 1:1 &amp; DI 2:1 2: select input DI 1:2 &amp; DI 2:2 3: select input DI 1:3 &amp; DI 2:3 4: select input DI 1:4 &amp; DI 2:4 5: The SAR function is always on.</p> <p>This parameter sets the digital input that is connected to the input of the SSR function. The truth table is as follows:</p> <table border="1"> <thead> <tr> <th>Options</th> <th>FS_MCU1</th> <th>FS_MCU2</th> </tr> </thead> <tbody> <tr> <td>0</td> <td>No select</td> <td>No select</td> </tr> <tr> <td>1</td> <td>Select DIN1_1</td> <td>Select DIN1_2</td> </tr> <tr> <td>2</td> <td>Select DIN2_1</td> <td>Select DIN2_2</td> </tr> <tr> <td>3</td> <td>Select DIN3_1</td> <td>Select DIN3_2</td> </tr> <tr> <td>4</td> <td>Select DIN4_1</td> <td>Select DIN4_2</td> </tr> <tr> <td>5</td> <td>Always on</td> <td>Always on</td> </tr> </tbody> </table>	Options	FS_MCU1	FS_MCU2	0	No select	No select	1	Select DIN1_1	Select DIN1_2	2	Select DIN2_1	Select DIN2_2	3	Select DIN3_1	Select DIN3_2	4	Select DIN4_1	Select DIN4_2	5	Always on	Always on
Options	FS_MCU1	FS_MCU2																										
0	No select	No select																										
1	Select DIN1_1	Select DIN1_2																										
2	Select DIN2_1	Select DIN2_2																										
3	Select DIN3_1	Select DIN3_2																										
4	Select DIN4_1	Select DIN4_2																										
5	Always on	Always on																										
SSR upper limit	P10.3	-60000.00	60000.00	rpm	1000.00	–	Sets the motor speed upper limit for the SSR function.																					
SSR lower limit	P10.4	-60000.00	60000.00	rpm	0	–	Sets the motor speed lower limit for the SSR function.																					
SSR t-delay	P10.5	0	3600.0	s	20.0	–	Sets the safety delay, the latest time at which the FS card activates SSR monitoring after an SSR request.																					
SSR Acknowledgement Mode	P10.6	0	5	–	0	0 = None 1 = DIN1_1 & DIN1_2 2 = DIN2_1 & DIN2_2 3 = DIN3_1 & DIN3_2 4 = DIN4_1 & DIN4_2 5 = Automatic	<p>Safety functions acknowledgement methods.</p> <p>0: No select Acknowledge. 1: select dual channel DI1 to manual acknowledge 2: select dual channel DI2 to manual acknowledge 3: select dual channel DI3 to manual acknowledge 4: select dual channel DI4 to manual acknowledge 5: Automatic acknowledge</p>																					

## 5 List of Parameters

### SAR Parameter

The SAR (Safe Acceleration Range) function keeps the motor deceleration within specified limits. FS card monitors motor deceleration and activate STO if the motor deceleration exceeds the specified limit.

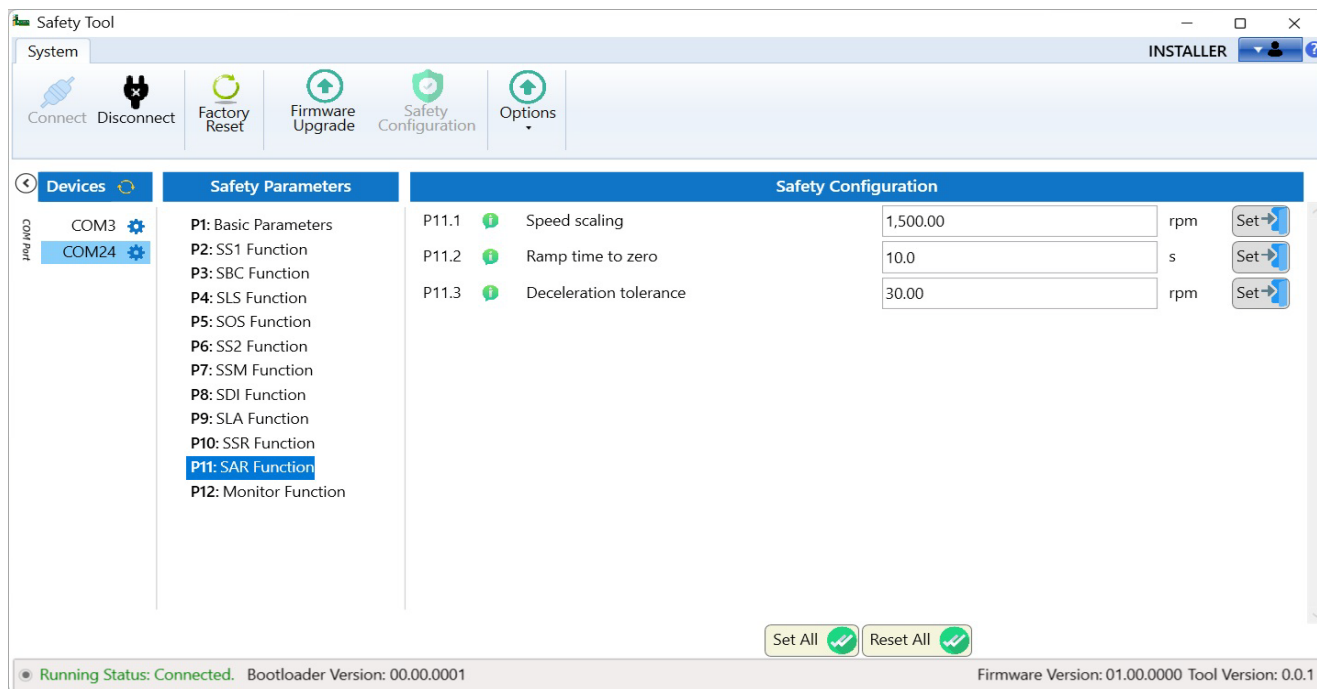

Parameter	Parameter Number	Min	Max	Unit	Default	Note	Description
<b>SAR Parameters (P11)</b>							
Speed scaling	P11.1	0	30000.00	rpm	1500.00	–	Sets a speed value that the FS card uses as a reference point in ramp time calculations.
Ramp time to zero	P11.2	0	3600.0	s	10.0	–	Sets the target time for the ramp decelerate. Target time = Time in which the drive decelerates the motor from speed scaling to zero.
Deceleration tolerance	P11.3	0	30000.00	rpm	30.00	–	The permitted decelerate tolerance during the ramp deceleration.

## Monitor Parameter

Following monitoring function give the status of each parameter.

The encoder position can only be shown if the SOS function is active.

All other values giving the status without any activation of safety functions.

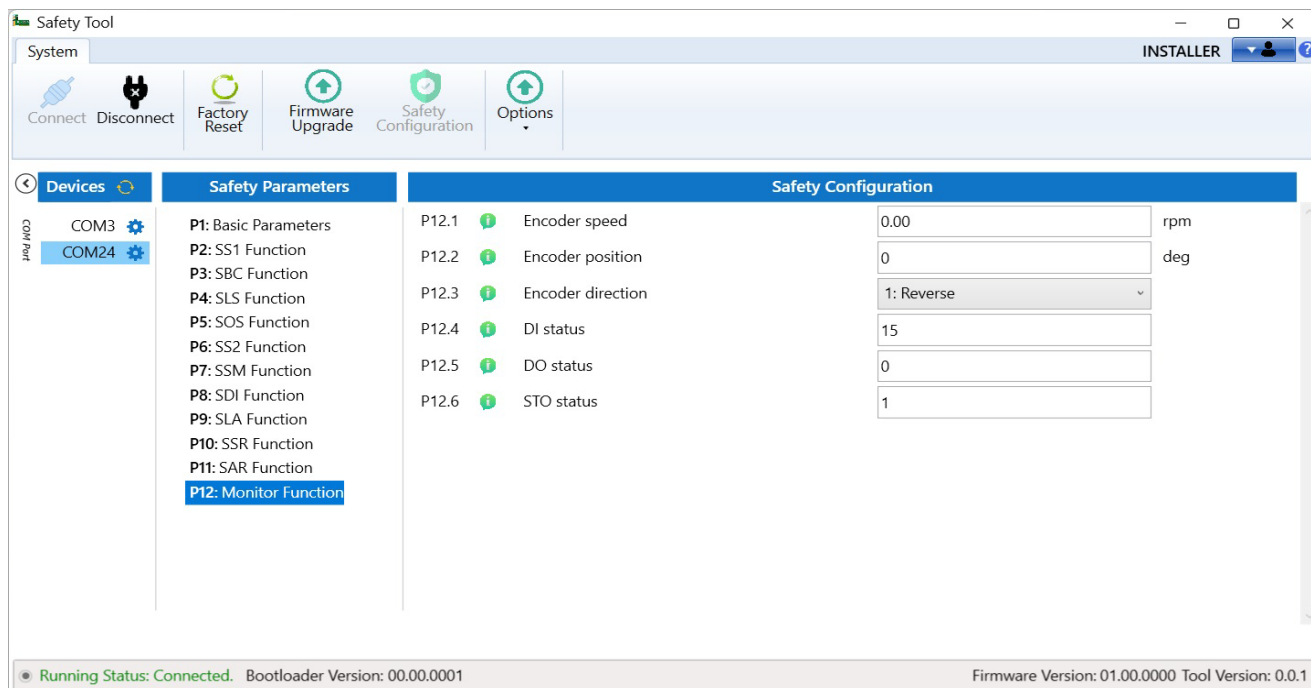

Monitor Function (P12)	Parameter Number	Description
Encoder speed	P12.1	Shows actual speed of motor in rpm
Encoder position	P12.2	Shows position of motor in degree (SOS activation required)
Encoder direction	P12.3	Shows actual speed in rpm with sign: + for FWD and – for REV
DI status	P12.4	Shows state of Digital Inputs
DO status	P12.5	Shows state of Digital Outputs
STO status	P12.6	Shows state of Safe Torque Off

Eaton is an intelligent power management company dedicated to protecting the environment and improving the quality of life for people everywhere. We make products for the data center, utility, industrial, commercial, machine building, residential, aerospace and mobility markets. We are guided by our commitment to do business right, to operate sustainably and to help our customers manage power – today and well into the future. By capitalizing on the global growth trends of electrification and digitalization, we're accelerating the planet's transition to renewable energy sources, helping to solve the world's most urgent power management challenges, and building a more sustainable society for people today and generations to come.

For more information, visit [Eaton.com](https://www.eaton.com).

**Eaton Industries GmbH**  
Hein-Moeller-Str. 7-11  
D-53115 Bonn

© 2025 Eaton  
All Rights Reserved  
01/26 MN040074EN