

Installation manual

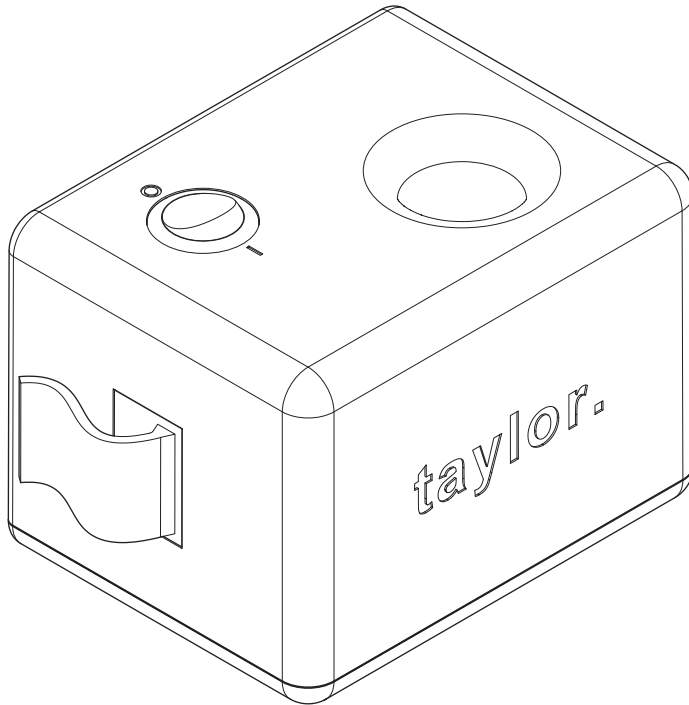

Taylor Technologies BV
Torenallee 32-14
5617 DB Eindhoven
The Netherlands

tel: +31 (0)85 107 1871
mail: support@taylor.solar
web: www.taylor.solar

Table of contents

1	About this document.....	2
1.1	Purpose of this document.....	2
1.2	How to use this document.....	2
1.3	Language.....	2
1.4	Symbols and signal words used in this document.....	2
2	Safety.....	3
2.1	General.....	3
2.2	Connect to the inverter.....	3
3	Packaging.....	4
4	Description.....	5
4.1	Overview of the system.....	5
4.2	Overview of the gateway.....	5
4.3	Data cables delivered seperate from gateway.....	5
4.4	Status shown by the indicator light in the power switch.....	6
4.5	Status shown by indicator lights 1 and 2.....	6
5	Installation.....	7
5.1	Preliminary equirements.....	7
5.2	Install the gateway.....	8
6	Declaration of conformity.....	11
7	Technical specification.....	11
7.1	Gateway.....	14
7.2	Smart module.....	14
8	Drill template.....	16

1 About this document

1.1 Purpose of this document

This document is only applicable for the gateway. Refer to the technical specifications for the applicable part numbers.

From here on, this document refers to the gateway as the equipment.

The equipment is part of a solar power system, from here on in this document referred to as the system.

The document is for approved personnel and gives the information that is necessary to install the equipment.

1.2 How to use this document





1. Make sure that you know the structure and contents of this document.
2. Read the safety chapter and make sure that you know all the instructions.
3. Do the steps in the procedures fully and in the correct sequence.
4. Keep the document in a safe location that you can easily access.

This document is a part of the equipment.

1.3 Language

The original instructions of this document are in English (EN-US). All other language versions are translations of the original instructions.

1.4 Symbols and signal words used in this document

Symbol	Signal word	Description
	Warning	Obey the instruction. If not, this can cause injury.
	Caution	Obey the instruction. If not, this can cause damage to the machine, to equipment or to property.
	Note	A note gives more data, to make it easier to do the steps, for example.
	-	Read the instructions.

2 Safety

2.1 General



WARNING:

- Before you switch the inverter on or off, stop the gateway. Set the power switch of the gateway in the off position (0).
- Incorrect installation can cause electric shock or can cause damage to the equipment and property. Obey the local regulations and electrical standards. The system must be installed and maintained by trained and authorized personnel.
- The gateway is designed to apply within the Taylor system, do not use it for any other purposes.
- Use the equipment only in combination with inverters that are approved by Taylor.
- Before you install the equipment, read all instructions.
- When the photovoltaic array is exposed to light, it supplies a DC voltage.
- Read the documentation and safety instructions of the inverter.
- Do not disconnect the junction box under load.
- Do not install the equipment in areas that contain flammable materials or gases.
- Install the equipment in a dry location.
- If the power cable has damage, switch off the gateway and remove the power source before you touch the power cable.
- If the equipment has damage, disconnect the power cable. Replace the equipment.
- Do not open the equipment.
- Do not make changes to the equipment.
- Recycle the equipment as electronic waste. Do not put the equipment in unsorted municipal waste. Obey the local regulations.

2.2 Connect to the inverter



Caution:

- On the inverter, do not connect more than one string of solar panels to an MPPT connection.
- Refer to the documentation of the inverter.

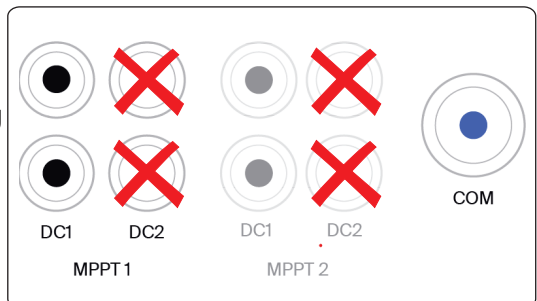

3 Packaging

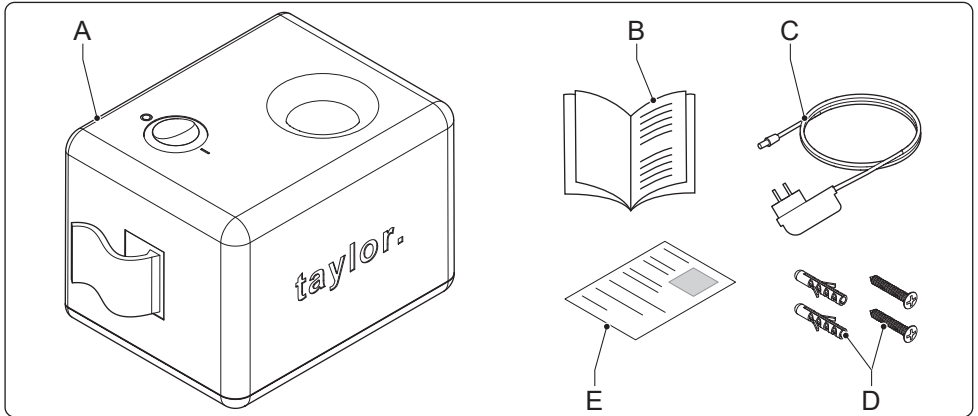

- A. Gateway
- B. Installation manual
- C. Power cable
- D. Fastening materials
- E. Drill template

4 Description

4.1 Overview of the system

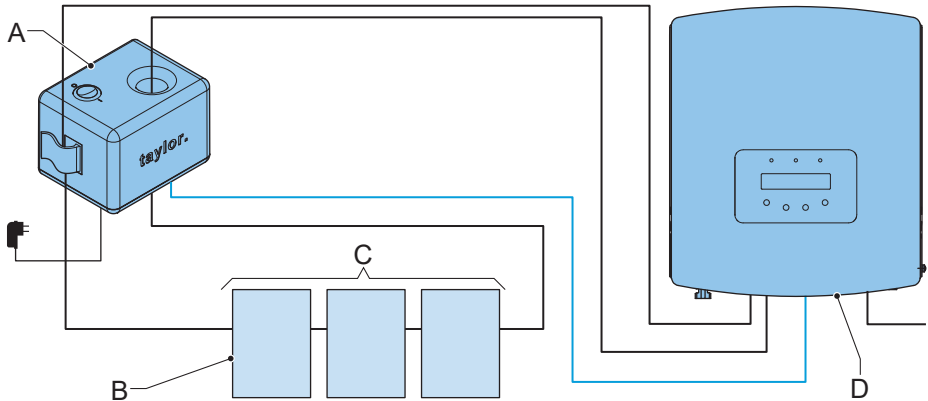

- A. Gateway
- B. Solar panel
- C. String of solar panels
- D. Inverter

4.2 Overview of the gateway

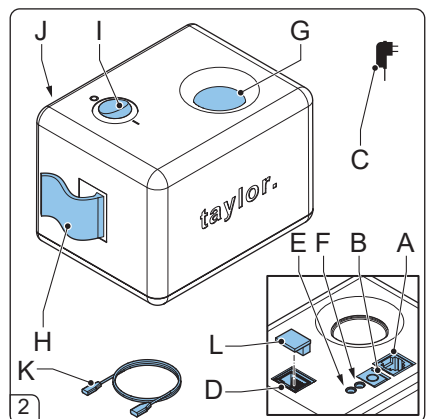

- A. Inverter data connection
- B. Power connection
- C. Power adapter
- D. LAN connection
- E. Indicator light 1
- F. Indicator light 2
- G. PV cable feed-through hole
- H. Cable clamp
- I. Power switch with indicator light
- J. Identification plate
- K. Datacable
- L. Cap



4.3 Data cables delivered separate from gateway

Data cable	Part number (P/N)	To use with this inverter
A.	TAYLOR-GTW-C-00	Goodwe
B.	TAYLOR-GTW-C-SL	Solis

4.4 Status shown by the indicator light in the power switch

Indicator light in the power switch		Status of the gateway	Remarks
	On	On	The system produces energy. The cable from the solar string is energized.
	Off	Off	When the gateway is off, the system is in safety mode. The cable from the solar string has approximately 1 Volt per solar panel.  Warning: To make sure that the system is in safety mode, disconnect the power adapter of the gateway.

4.5 Status shown by indicator lights 1 and 2

Indicator light 1	Indicator light 2	Equipment status
Flashes 7 times	Off	There is a connection with the 4G network.
On	Off	The gateway updates the software
Flashes	Off	The gateway does a factory reset.

5 Installation

5.1 Preliminary requirements

1. Scan the barcode of each individual solar panel. In the onboarding application on your mobile device, On the 'Scan' screen (A), select the 'Scan' button (B).

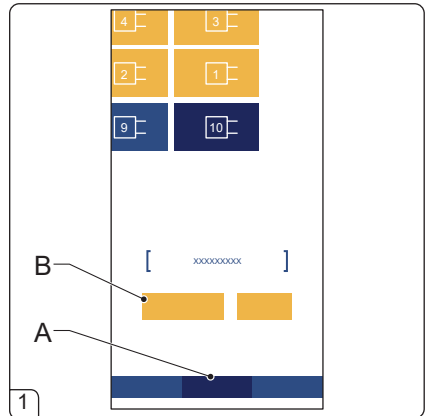

2. The solar panels (A) are installed and the smart modules (B) are connected.
3. The inverter is installed.



Warning:

- Obey the instructions that come with the solarpanels, the smart modules and the inverter.
- When the photovoltaic array is exposed to light, it supplies a DC voltage.

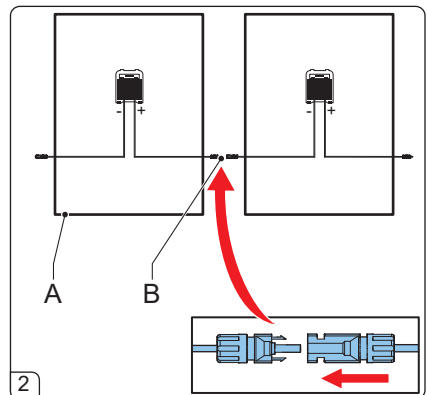

Design rules

- Multiple orientations within one string are allowed
- Each orientation should reach the start-up voltage (input DC)

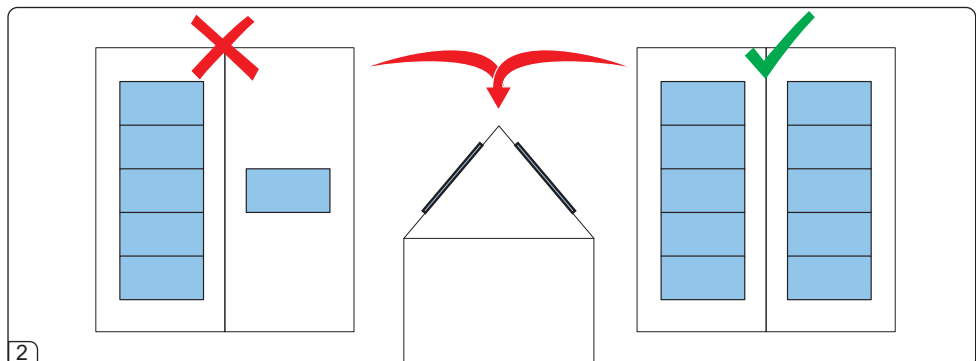

5.2 Install the gateway.



Warning:

- Obey the safety instructions of the inverter.
- Make sure that the inverter is off and de-energized.
- Do not connect more than one string of solar panels to a MPPT connection.
- Do not connect parallel module strings per MPPT tracker

1. Scan the gateway. Select the 'SCAN GTW' button (A).

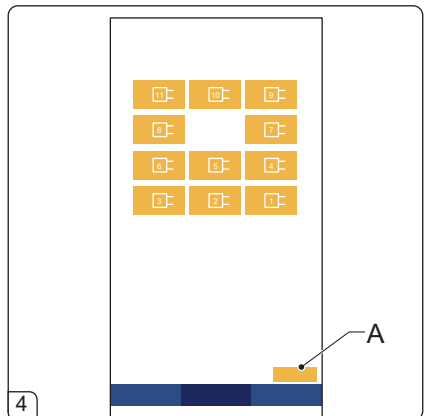
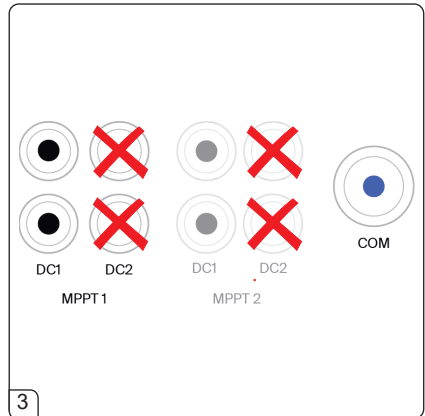

Note: If necessary, drill holes. Drill safely. Do not drill or screw in electricity lines, water pipes, and such items. Use the correct type of wall plugs.

2. Install the fasteners. Use the drill template on the last page of this manual.
3. Attach the gateway to the fasteners (B).

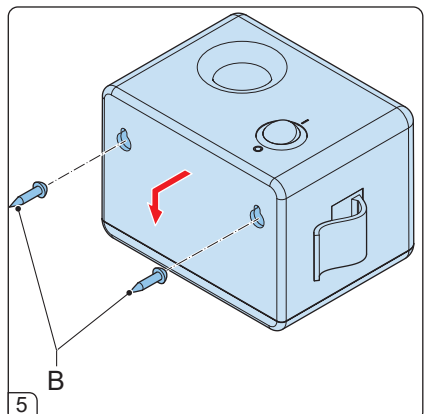



Caution: Never put both cables through the hole (B).

4. Put one of the cables (A) (either + or -) through the hole (B).
5. Put the other cable through the clamp (C)

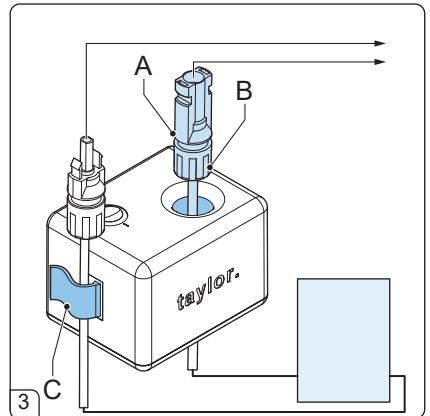

6. Connect the cables to the inverter (D). Refer to the documentation of the inverter

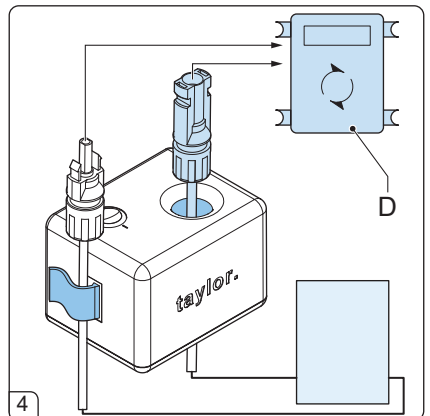

7. Connect the data cable to the inverter (B). Refer to the website: www.taylor.solar > Downloads > Manuals.
8. Connect the data cable to the data connection (A).

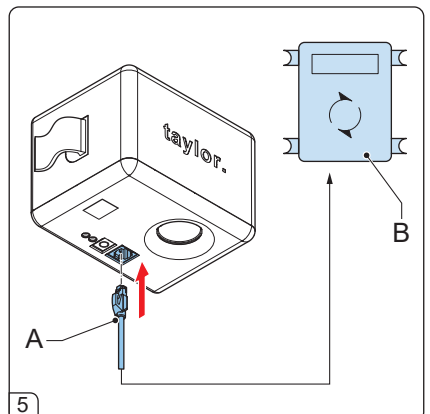

9. Connect the power cable (A).
10. Put the power adapter (B) in a wall socket.

- Warning:** - Make sure that the solarpanels, the smart modules and the inverter are installed correctly.
- Before you switch the inverter on or off, stop the gateway. Set the power switch of the gateway in the off position (0).
11. Start the inverter. On the inverter, set the DC switch to on.

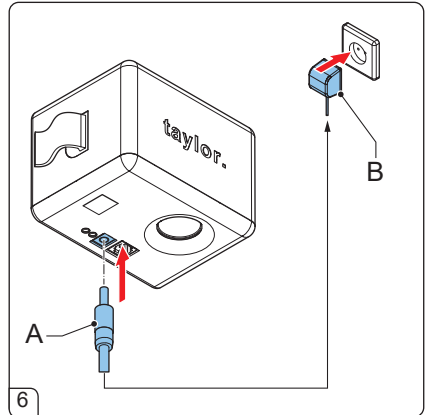

12. On the 'launch' screen (A), select the 'launch' button (B). When the system onboarding is confirmed, the customer receives an e-mail to register to the Taylor dashboard.

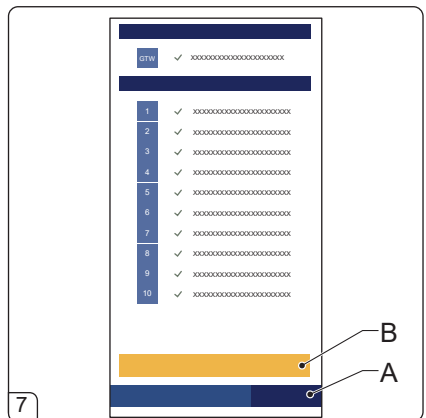

13. Set the switch (A) in the on position. The light in the switch comes on.

- i Note:**
- A few seconds may be necessary for the system to start.
 - If a 4G connection is not available, use a wired LAN connection. If a wifi connection is necessary, please refer to Taylor.

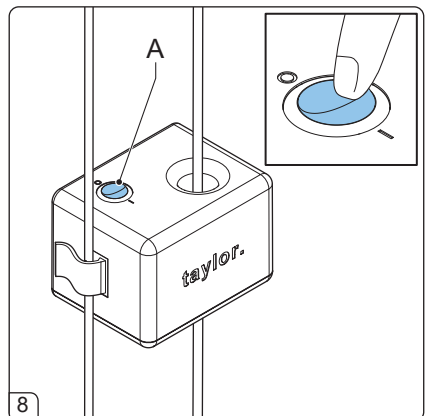

6 Declaration of conformity

Hereby, Taylor Technologies B.V. declares that the radio equipment type TAYLOR-GTW-2A is in compliance with Directive 2014/35/EU. The full text of the EU declaration of conformity is available at this internet address: www.taylor.solar/declaration.

7 Technical specifications

7.1 Gateway

Item		Specification	Value
Gateway	Input	Part number (P/N)	TAYLOR-GTW-2A
		Voltage	12 VDC
		Maximum current	1.5 A
		Maximum power	18 W
	Environment	IP code	IP3X
		environmental category	indoor, unconditioned
		maximum altitude rating	2000 meter
		Temperature	Operating: (0 ~ 40)°C Storage: (-20 ~ 85)°C
		Humidity	Operating: (8 ~ 90)% RH Storage: (5 ~ 95)% RH non condensing
	Frequency bands	Cat-M	B1/B2/B3/B4/B5/B8/B12/B13/B14/ B18/B19/B20/B25/B26/B27/B28/ B66/B85
		Cat-NB	B1/B2/B3/B4/B5/B8/B12/B13/B18/ B19/B20/B25/B26/B28/B66/B71/B85
		GSM	850/900/1800/1900 MHz
	Radio transmitted power	LTE RF Power Class	Class 5 (Typ. 21dbm)

Power adapter	Output	Model	SYS1308-2412-W2E
		Min. Load	0 A
		Max. load	2 A \pm 5%
		OCP	3.5~5.5 A
		OVP	14~16 V
		Efficiency	>70%
		Max. power	24 W
		Ripple & N	120 mV
		Oversvoltage category	II
	input	Voltage	(90 ~ 264) VAC
		Frequency	(47 ~ 63) Hz
		Current	1A @ 230VAC
		Surge Current max.	60Amax. @ at 240Vac input, with rated load and 25° ambient
		Leakage current	<0.25 mA @ 240Vac input
	protection	Over load OCP	Fold back
		Over Voltage OVP	Voltage limiting
		Short Circuit	Yes, Output to Ground, Auto recovery when fault has been removed. Short Current & Over Current can not exceed 8A max. after 1minute at nominal line input.
		Protection	class II
		No Load Operation	Yes, to protect the power supply and system from damage
	others	Dielectric Strength	HI-POT B / I/P-O/P (FG): 3KVAC / 10mA / 1 minute
Set up time		7s max. @ AC low line Input & Output full load	

		Hold-up Time	10ms @ AC nominal Input and Output full load
		MTBF Qualification	> 35K hours
		DC cable & connector	Standard length of the cable 1,8m & It depends on customer requirements and upon specifications
		Efficiency (Normal)	>77.6% min. @ 240VAC input & Full load
		Power Consumption	Max. 0.5W @ AC nominal Input and Output min. load
		Input Fuse	1A protected against power line surges and any abnormal conditions
	EMC	EMI	EN55022 Class B / FCC part 15 subpart B Class B / EN61000-3-2(2000) / EN61000-3-3(1995) + A1(2001)
		EMS	IEC61000-4-2,5,8(2001) / IEC61000-4-3(2002) / IEC61000-4-6(2002)+A1(2003) / IEC61000-4-4,11(2004) EN55024(1998)+A1(2001)+A2(2003)

7.2 Smart module

Cell-stringoptimizer: CSO-72	
Input	Cell-string (3 per module)
Input MPP voltage range	7.5Vdc – 20Vdc
Rated for solar PV modules with max. Voc at lowest temperature	20V
Rated for solar PV modules with max. Impp at STC	11.5

Output operational mode	Cell-string (3 per module)	Module
Nominal output current (STC)		12V
Nominal output voltage (STC)	10V	30V
Max. output current limit		14A
Max. bypass current		14A
Max. output voltage if installed on solar module	Voc of cell-string	Voc of solar module
Max. output voltage if separate from solar module	20V	60V
Max. output power		475W
Max. reverse current		0A

Output safe mode	
Output voltage	1.1±10%Vdc

Compliance	
Junction box certification	IEC 62790, IEC 62109-3
RoHS	Yes

General data	
Operating temperature range junction box	-40 °C / +85 °C
Output wire	2x 1.2 m 4mm ² (standard configuration)
Connectors	MC4 (standard configuration)
Overvoltage category	III
Pollution degree	Pollution 1 for potting part Pollution 2 for non-potting part
Degree of protection	P65/IP67
Protection class	II
Max. system voltage	1000V

8 Drill template

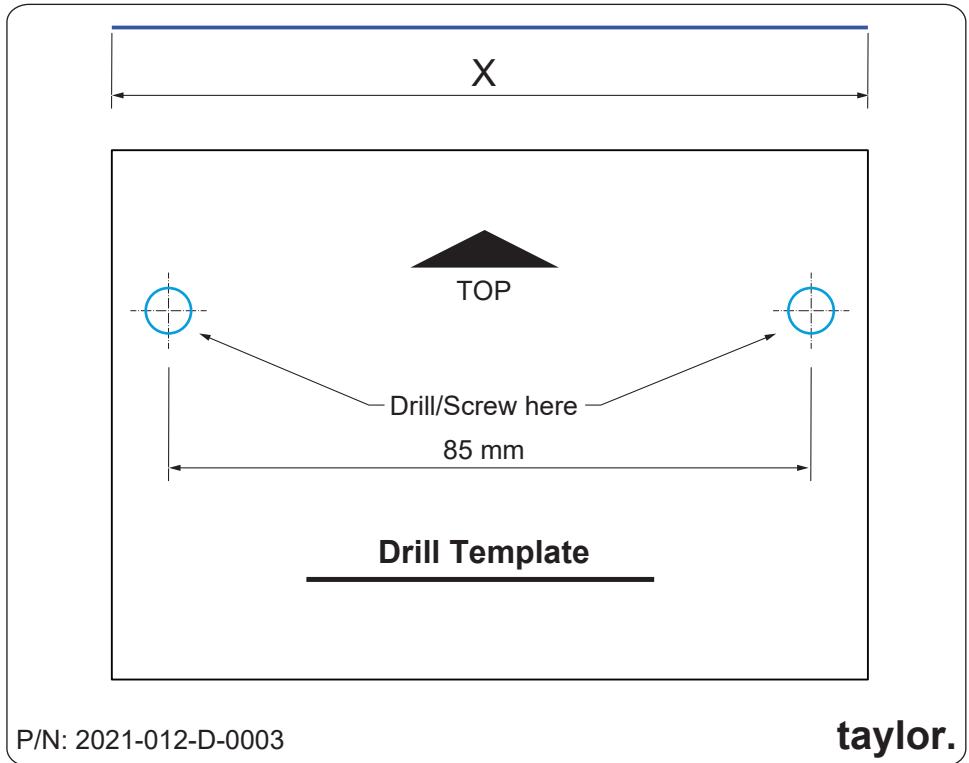

CAUTION:

- Measure the control line (X). If the control line is not 100 mm, do not use this drill template.
- Do not drill or screw in electricity lines, water pipes, and such items. Drill safely.

Use the wall plugs, use a 06 diameter drillbit size and Pozidriv Z1 for driver.

