

Explosionproof version of the
weatherproof FernTel 3 telephone

FernTel 3 Z2



Operating manual



The FernTel 3 Z2 telephone is an explosionproof version of the weatherproof FernTel 3 telephone with all its features. The operating manual is still valid, with the addition of the following items.

Operation

The FernTel 3 Z2 telephone is used as a stationary device in areas potentially endangered by an explosive gas or dust atmosphere.

Designed for Device Group II and Categories 3G and 3D, it may be operated within zones 2 and 22.

The FernTel 3 Z2 telephone may only be operated in the analogue, public telephone network and via analogue terminals of branch exchanges.

Commissioning

After having been connected to the telephone line, the telephone is operational.

Operating utilization position

The telephone may be mounted on a wall or used as a desk telephone.

Service

The telephone contains no serviceable parts.

Care and maintenance

The telephone is maintenance-free. Still, if the operating area is highly contaminated by dust, fat, oil etc., the device should be cleaned from time to time.

The device may only be cleaned using a damp cloth in order to avoid electrostatic charging.

Never use sharp objects for cleaning.

During maintenance, check accessible seals for function, e.g. regarding possible damage or positioning. If the seals are damaged, operating the telephone is not allowed. Damaged seals must be replaced.

Disposal

The complete device should be disposed of as electronic waste. When the device is disassembled, plastics, metals and electronics components are to be disposed of separately. In every single case the national requirements and regulations for waste disposal must be observed.

Warnings and security information

This device is an explosionproof, weatherproof telephone especially designed for use in rough industrial environments.

Please note the following warnings and security information:

- The installation and adjustment of the device must be carried out by qualified personnel in accordance with the prescribed installation regulations taking the specified types of protection into account.
- This apparatus is a Protective Class II device and may only be connected to and operated at the voltage it was designed for.

Make sure the connections are in perfect order.

- Make sure the telephone housing, the connecting cable and the receiver cord are not damaged. If the device is damaged, it may not be operated.
- While operating the device in commercial facilities, the accident prevention regulations of the Employers' Liability Insurance Association regarding the use of electrical systems and devices must be observed.
- The device may be operated solely under the stated ambient conditions. Unfavourable ambient conditions can lead to damage of the device and thus present a potential danger for the user.

Unfavourable ambient conditions include:

- Humidity of air too high (>75% rel., condensing)
- moisture, dust (pay attention to the degree of protection)
- flammable gases, vapours and solvents not covered by the device's type of protection
- too high ambient temperatures (>+55°C)
- too low ambient temperatures low (<-20°C)
- During operation of the device the temperature must not exceed nor fall below the prescribed range of ambient temperatures. It is not allowed to operate the device with an additional cover.
- Repairs may be carried out by the manufacturer or by a person appointed by the manufacturer followed by a renewed product conformity inspection.
- Make sure the wiring is disconnected from the power supply upon connecting or disconnecting the wires in the terminal room.
- If electrical connections must be carried through in the hazardous area, the enclosure must be opened and closed as follows:
 - Remove voltage from the device
 - Loosen the fastening screws from the keypad insert
 - Remove the keypad insert and unfasten the keypad cable

- Make the connections while the device is open
- When the work is done, plug the keypad back on, and place the keypad insert back on the lower part of the device.

Make sure the seal is correctly positioned and in perfect working order. Then tighten the fastening screws in a diagonal pattern.

- Only blind plugs and cable glands as prescribed by the manufacturer may be used.

Should these points not be observed, the explosion protection of the device cannot be guaranteed. The device then poses a potential threat to the user's life and can cause the ignition of an explosive atmosphere.

CE symbol

The FernTel 3 Z2 fulfils the demands of the R&TTE Directive 1995/5/EC and the ATEX directive 94/9/EC. The CE symbol confirms the conformity of the device with the above-mentioned Directives.

EMC-Directive

The device complies with the requirements of the new EMC-directive 2004/108/EC, the low voltage directive 2006/95/EC and the R&TTE directive 1999/5/EC.

The conformity with the above directives is confirmed by the CE sign.

Technical Specifications

Electrical characteristics

Connection data	DC voltage	La / Lb: Ui = 66 Vdc
	Ringing voltage	24 Vac - 90 Vac / 16 Hz...68 Hz

Sounder input impedance	$\geq 6.0 \text{ k}\Omega$ at 25 Hz
	$\geq 3.5 \text{ k}\Omega$ at 50 Hz

General specifications

Enquiry key (flash)	for dual-tone multifrequency only	80 ms, 120 ms, 600 ms
Dialling procedure	Dual-tone multifrequency	Frequencies according to ITU-T Q.23 Tone duration unlimited or 90 ms
	Pulse dialling	Pulse/Pause ratio 1.5: 1 (60 ms/40 ms) or 2:1 (66.7/33.3 ms)

Ringing volume	max. approx. 95 dB(A) at 1 m distance
----------------	---------------------------------------

Housing	Height x Width x Depth	293 x 191 x 128 mm
Weight		Approx. 2300 g
Receiver	Microphone	Electret-foil microphone
	Receiver inset	dynamic receiver inset with magnetic field generator

Connecting terminals

Labelling

Power cable	2-pin	TCP/La - TCP/Lb
Secondary sounder cable	2-pin	W - W1

Conductor cross section

flexible	fine-wired	0.75 – 2.5 mm ² / AWG14
rigid	single wired	0.75 – 2.5 mm ² / AWG14

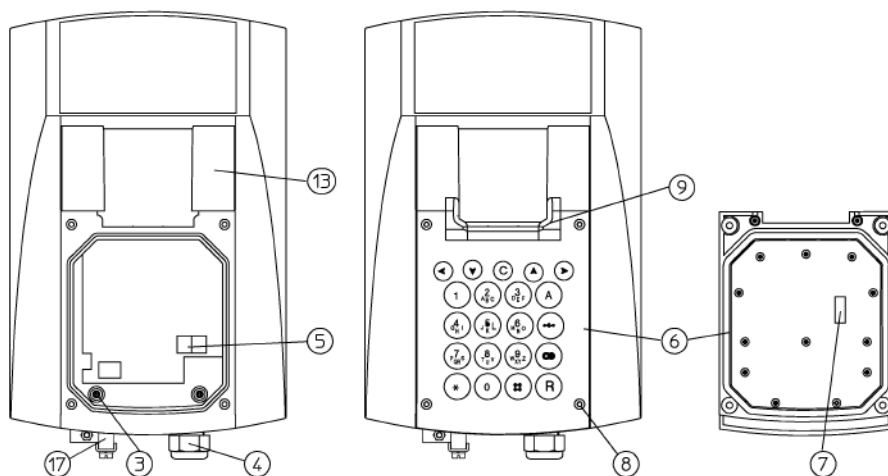

When connecting the wire, observe the fulfilment of the Class II requirements as follows:

1. For connection always use the required terminal **(5)**
2. The shielding isolation must be long enough to reach at least to the upper edge of the cable gland.
3. The exposed conductors, from which the isolation has been removed, must be situated in the terminals.

In order to avoid electrostatic discharge, the potential must be evened out. **(17)**

Dimensions connecting cable / cable entry

Cable entries	M20 x 1.5 / M12 x 1.5
Blind plugs	M20 x 1.5 / M12 x 1.5
Connecting cable diameter	6 – 13 mm
Connection potential compensation	1.5 – 4 mm ²

Ambient temperature range and explosion protection

Type of protection	II 3 G Ex nA L IIC T5 II 3 D Ex tD A22 IP65 80°C
Ambient operating temperature	-20°C ≤ Ta ≤ +55°C
Storage and transport temperature	-25°C ≤ T ≤ +70°C
Housing degree of protection	IP 65

Labelling

Company	FHF Funke+Huster Fernsig GmbH
Type	FernTel 3 Z2 20°C ≤ Ta ≤ +55°C IP 65 Ui = 66 Vdc / 90 Vac II 3 G Ex nA L IIC T5 / II 3 D Ex tD A22 IP65 80°C
DEKRA	BVS 07 ATEX E 098 Do not open while energized. For cleaning moist cleaning-rag must be used
CE 0158 	II 3 G Ex nA L IIC T5 / II 3 D Ex tD A22 IP65 80°C
IECEX	Ex nAnL IIC T5 IECEX BVS 08.0008

EG-KONFORMITÄTSERKLÄRUNG EC DECLARATION OF CONFORMITY DECLARATION CE DE CONFORMITE DECLARACIÓN DE CONFORMIDAD CE

Bezeichnung des Erzeugnisses: / Designation of Product:
Désignation du produit : / Designación del producto:

- Telefon
- Telephone
- Téléphone
- Teléfono

Gerätetyp oder Typenbezeichnung der Einzelkomponenten:
Equipment Type or Type Designation of Individual Component:
Modèle d'appareil ou désignation de modèle des composants :
Tipo de aparato o designación del tipo de los componentes individuales:

■ FernTel 3 Z2

Einschlägige EG-Richtlinie(n) / Relevant EC Directive(s):
Directive(s) CE en vigueur : / Directiva(s) CE pertinente(s):

**94/9/EG: Geräte und Schutzsysteme zur bestimmungsgemäßen
Verwendung in explosionsgefährdeten Bereichen**
**94/9/EC: Equipment and protective systems intended for use in
potentially explosive atmospheres**
**94/9/CE: Appareils et systèmes de protection destinés à être utilisés
en atmosphères explosibles**
**94/9/CE: Aparatos y sistemas de protección para uso en atmósferas
potencialmente explosivas**

Angewandte harmonisierte Normen, insbesondere:
The following harmonised standards have been applied:
Normes harmonisées appliquées, notamment :
Normas armonizadas aplicadas, especialmente:

EN 60079-0 :2006
EN 60079-15 :2005
IEC 61241-0 :2006
EN 61241-1 :2004

EG-Baumusterprüfbescheinigung: / EC-Type Examination Certificate:
Attestation d'examen CE de type : / Certificado de examen CE:

BVS 07 ATEX E 098

Benannte Stelle für die Überwachung:
Notified body of inspection:
Organisme notifié de contrôle:
Organismo encargado del examen:

Kennnummer:
Inspection number: /
Número d'identification : /
Número de examen:

0158

■ Hiermit erklären wir, dass das nachfolgend bezeichnete Erzeugnis aufgrund seiner Konzipierung und Bauart sowie in der von uns in Verkehr gebrachten Ausführung den einschlägigen grundlegenden Sicherheits- und Gesundheitsanforderungen der(n) genannten EG-Richtlinie(n) entspricht. **Bei einer nicht mit uns abgestimmten Änderung des Erzeugnisses verliert diese Erklärung ihre Gültigkeit.**

■ We herewith declare that the product identified below, based on its development and type as well as on the specific design we have brought into circulation, conforms to the relevant basic safety and health requirements of the EC Directive(s) cited below.

This declaration shall become invalid if any modification we have not authorised is made to the product.

■ Nous attestons, par le présent document, que le produit désigné ci-après a été conçu et fabriqué, quant au modèle mis en circulation par nos services, conformément aux exigences fondamentales de sécurité et de santé en vigueur de la ou des directives CE citées.

En cas de modification du produit non convenue avec nos services, la présente déclaration perd sa validité.

■ Por la presente declaramos que el siguiente producto satisface por su diseño y tipo constructivo así como en la versión comercializada por nosotros los requisitos de seguridad y salud fundamentales y pertinentes de la(s) directiva(s) CE indicada(s).

En caso de una modificación del producto no acordada con nosotros, la presente declaración pierde su validez.

Diese Erklärung wird verantwortlich für den Hersteller / Importeur - This declaration is made on behalf of the manufacturer / importer - La présente déclaration, dont le fabricant / importateur ci-après assume la responsabilité - Esta declaración es formulada en forma responsable para el fabricante / importador

FHF Funke + Huster Fernsig GmbH

Gewerbeallee 15-19

45478 Mülheim an der Ruhr

Deutschland · Germany · Allemagne · Alemania

abgegeben durch / by the authorised signatory - est déposée par · por

Dr. Opitz, Hans-Peter

Name, Vorname / Surname, forename / nom, prénom / apellido y nombre

Geschäftsführung / Managing Director / Direction / Gerencia

Stellung im Betrieb des Herstellers / Position in manufacturer's company /
fonction dans l'entreprise du fabricant / puesto en la empresa del fabricante

Mülheim an der Ruhr

Ort / Place / ville / Lugar

Datum / Date / date / Fecha

Rechtsgültige Unterschrift / Legally binding signature / signature légale / Firma válida

Subject to alterations
or errors



FHF Funke + Huster Fernsig GmbH

Gewerbeallee 15-19 · D-45478 Mülheim an der Ruhr
Phone +49/208/82 68-0 · Fax +49/208/82 68-286
<http://www.fhf.de> · e-mail: info@fhf.de