



<b>Prüfbericht-Nr.:</b> <i>Test report no.:</i>	<b>CN25AHJ7 001</b>	<b>Auftrags-Nr.:</b> <i>Order no.:</i>	326124461 P02055082	Seite 1 von 48 Page 1 of 48
<b>Kunden-Referenz-Nr.:</b> <i>Client reference no.:</i>	2028101	<b>Auftragsdatum:</b> <i>Order date:</i>	2025-8-11	
<b>Auftraggeber:</b> <i>Client:</i>	GoodWe Technologies Co., Ltd. No.90 Zijin Rd., New District, 215011 Suzhou P.R. China			
<b>Prüfgegenstand:</b> <i>Test item:</i>	Hybrid Inverter, AC-Coupled Inverter			
<b>Bezeichnung / Typ-Nr.:</b> <i>Identification / Type no.:</i>	<b>Hybrid Inverter:</b> GW5K-ETA-G20, GW6K-ETA-G20, GW8K-ETA-G20, GW9.999K-ETA-G20, GW10K-ETA-G20, GW12K-ETA-G20, GW15K-ETA-G20, GW20K-ETA-G20, GW25K-ETA-G20, GW29.999K-ETA-G20, GW30K-ETA-G20 <b>AC-Coupled Inverter:</b> GW5K-BTA-G20, GW6K-BTA-G20, GW8K-BTA-G20, GW9.999K-BTA-G20, GW10K-BTA-G20, GW12K-BTA-G20, GW15K-BTA-G20, GW20K-BTA-G20, GW25K-BTA-G20, GW29.999K-BTA-G20, GW30K-BTA-G20			
<b>Auftrags-Inhalt:</b> <i>Order content:</i>	Test Report			
<b>Prüfgrundlage:</b> <i>Test specification:</i>	IEC 60730-1:2022 Annex H			
<b>Wareneingangsdatum:</b> <i>Date of sample receipt:</i>	2025-09-20			
<b>Prüfmuster-Nr.:</b> <i>Test sample no.:</i>	Engineering sample			
<b>Prüfzeitraum:</b> <i>Testing period:</i>	2025-09-20 - 2025-11-14			
<b>Ort der Prüfung:</b> <i>Place of testing:</i>	No.90 Zijin Rd., New District, 215011 Suzhou P.R. China			
<b>Prüflaboratorium:</b> <i>Testing laboratory:</i>	TÜV Rheinland (Shanghai) Co., Ltd.			
<b>Prüfergebnis*:</b> <i>Test result*:</i>	Pass			
<b>geprüft von:</b> tested by: Zheming Luo & Vincent Guan	<b>genehmigt von:</b> authorized by: Ding Guan			
<b>Datum:</b> Date: 2025-11-28				
<b>Stellung / Position:</b>	Trainee & Project Engineer	<b>Stellung / Position:</b>	Authorizer	
<b>Sonstiges /</b> <i>Other:</i>	N/A.			
<b>Zustand des Prüfgegenstandes bei Anlieferung:</b> <i>Condition of the test item at delivery:</i>	Prüfmuster vollständig und unbeschädigt <i>Test item complete and undamaged</i>			
* Legende:	P(ass) = entspricht o.g. Prüfgrundlage(n)	F(ail) = entspricht nicht o.g. Prüfgrundlage(n)	N/A = nicht anwendbar	N/T = nicht getestet
* Legend:	P(ass) = passed a.m. test specification(s)	F(ail) = failed a.m. test specification(s)	N/A = not applicable	N/T = not tested
<p><b>Dieser Prüfbericht bezieht sich nur auf das o.g. Prüfmuster und darf ohne Genehmigung der Prüfstelle nicht auszugsweise vervielfältigt werden. Dieser Bericht berechtigt nicht zur Verwendung eines Prüfzeichens.</b>  <i>This test report only relates to the above mentioned test sample. Without permission of the test center this test report is not permitted to be duplicated in extracts. This test report does not entitle to carry any test mark.</i></p>				

**Anmerkungen**  
*Remarks*

1	<p>Alle eingesetzten Prüfmittel waren zum angegebenen Prüfzeitraum gemäß eines festgelegten Kalibrierungsprogramms unseres Prüfhauses kalibriert. Sie entsprechen den in den Prüfprogrammen hinterlegten Anforderungen. Die Rückverfolgbarkeit der eingesetzten Prüfmittel ist durch die Einhaltung der Regelungen unseres Managementsystems gegeben. Detaillierte Informationen bezüglich Prüfkonditionen, Prüfequipment und Messunsicherheiten sind im Prüflabor vorhanden und können auf Wunsch bereitgestellt werden.</p> <p><i>The equipment used during the specified testing period was calibrated according to our test laboratory calibration program. The equipment fulfils the requirements included in the relevant standards. The traceability of the test equipment used is ensured by compliance with the regulations of our management system. Detailed information regarding test conditions, equipment and measurement uncertainty is available in the test laboratory and could be provided on request.</i></p>
2	<p>Wie vertraglich vereinbart, wurde dieses Dokument nur digital unterzeichnet. Der TÜV Rheinland hat nicht überprüft, welche rechtlichen oder sonstigen diesbezüglichen Anforderungen für dieses Dokument gelten. Diese Überprüfung liegt in der Verantwortung des Benutzers dieses Dokuments. Auf Verlangen des Kunden kann der TÜV Rheinland die Gültigkeit der digitalen Signatur durch ein gesondertes Dokument bestätigen. Diese Anfrage ist an unseren Vertrieb zu richten. Eine Umweltgebühr für einen solchen zusätzlichen Service wird erhoben. Informationen zur Verifizierung der Authentizität unserer Dokumente erhalten Sie über folgenden Webseite: <a href="http://go.tuv.com/digital-signature">go.tuv.com/digital-signature</a></p> <p><i>As contractually agreed, this document has been signed digitally only. TUV Rheinland has not verified and unable to verify which legal or other pertaining requirements are applicable for this document. Such verification is within the responsibility of the user of this document. Upon request by its client, TUV Rheinland can confirm the validity of the digital signature by a separate document. Such request shall be addressed to our Sales department. An environmental fee for such additional service will be charged. For information on verifying the authenticity of our documents, please visit the following website: <a href="http://go.tuv.com/digital-signature">go.tuv.com/digital-signature</a></i></p>
3	<p>Prüfklausel mit der Note * wurden an qualifizierte Unterauftragnehmer vergeben und sind unter der jeweiligen Prüfklausel des Berichts beschrieben. Abweichungen von Prüfspezifikation(en) oder Kundenanforderungen sind in der jeweiligen Prüfklausel im Bericht aufgeführt.</p> <p><i>Test clauses with remark of * are subcontracted to qualified subcontractors and described under the respective test clause in the report. Deviations of testing specification(s) or customer requirements are listed in specific test clause in the report.</i></p>
4	<p>Die Entscheidungsregel für Konformitätserklärungen basierend auf numerischen Messergebnissen in diesem Prüfbericht basiert auf der "Null-Grenzwert-Regel" und der "Einfachen Akzeptanz" gemäß ILAC G8:2019 und IEC Guide 115:2021, es sei denn, in der auf Seite 1 dieses Berichts genannten angewandten Norm ist etwas anderes festgelegt oder vom Kunden gewünscht. Dies bedeutet, dass die Messunsicherheit nicht berücksichtigt wird und daher auch nicht im Prüfbericht angegeben wird. Zu weiteren Informationen bezueglich des Risikos durch diese Entscheidungsregel siehe ILAC G8:2019.</p> <p><i>The decision rule for statements of conformity, based on numerical measurement results, in this test report is based on the "Zero Guard Band Rule" and "Simple Acceptance" in accordance with ILAC G8:2019 and IEC Guide 115:2021, unless otherwise specified in the applied standard mentioned on Page 1 of this report or requested by the customer. This means that measurement uncertainty is not taken in account and hence also not declared in the test report. For additional information to the resulting risk based of this decision rule please refer to ILAC G8:2019.</i></p>



<b>TEST REPORT</b> <b>IEC 60730-1</b> <b>Automatic electrical controls for household and similar use</b> <b>Controls using software</b>	
Report Number. ....:	CN25AHJ7 001
Date of issue .....	See cover page
Total number of pages .....	See cover page
Name of Testing Laboratory preparing the Report .....	See cover page
Applicant's name .....	See cover page
Address .....	See cover page
<b>Test specification:</b>	
Standard .....	See cover page
Test procedure.....	See cover page
Non-standard test method.....	N/A
Test Report Form No.....	IEC60730_1i_SOFTWARE
Test Report Form(s) Originator.....	TÜV Rheinland (Shanghai) Co., Ltd.
Master TRF .....	2025-11
<b>Copyright © 2018 IEC System of Conformity Assessment Schemes for Electrotechnical Equipment and Components (IECEE System). All rights reserved.</b> This publication may be reproduced in whole or in part for non-commercial purposes as long as the IECEE is acknowledged as copyright owner and source of the material. IECEE takes no responsibility for and will not assume liability for damages resulting from the reader's interpretation of the reproduced material due to its placement and context.	
<b>General disclaimer:</b>	
The test results presented in this report relate only to the object tested. The authenticity of this Test Report and its contents can be verified by contacting the NCB, responsible for this Test Report.	

Test Item description ..... Trade Mark ..... Manufacturer ..... Model/Type reference ..... Ratings ..... Software module(s) and associated version(s) .....	See cover page  <div style="text-align: center; font-size: 24pt; font-weight: bold; color: red;">GOODWE</div> See cover page See cover page See copy of marking label and model list HW version: 290-11189, 290-11188, 290-11238, 290-11187 SW Version: 010101
<b>Responsible Testing Laboratory (as applicable), testing procedure and testing location(s):</b>	
<input type="checkbox"/> <b>CB Testing Laboratory:</b>	
<b>Testing location/ address.....:</b>	
<b>Tested by (name, function, signature).....:</b>	
<b>Approved by (name, function, signature)....:</b>	
<input type="checkbox"/> <b>Testing procedure: CTF Stage 1:</b>	
<b>Testing location/ address.....:</b>	
<b>Tested by (name, function, signature).....:</b>	
<b>Approved by (name, function, signature)....:</b>	
<input type="checkbox"/> <b>Testing procedure: CTF Stage 2:</b>	
<b>Testing location/ address.....:</b>	
<b>Tested by (name + signature).....:</b>	
<b>Witnessed by (name, function, signature) .:</b>	
<b>Approved by (name, function, signature)....:</b>	
<input type="checkbox"/> <b>Testing procedure: CTF Stage 3:</b>	
<input type="checkbox"/> <b>Testing procedure: CTF Stage 4:</b>	
<b>Testing location/ address.....:</b>	
<b>Tested by (name, function, signature).....:</b>	
<b>Witnessed by (name, function, signature) .:</b>	
<b>Approved by (name, function, signature)....:</b>	
<b>Supervised by (name, function, signature) :</b>	

**List of Attachments (including a total number of pages in each attachment):**

- Attachment 1 - FMEA and fault insert testing



























**Summary of compliance with National Differences (List of countries addressed):**







N/A







**Copy of marking plate:**









The artwork below may be only a draft. The use of certification marks on a product must be authorized by the respective NCBS that own these marks.

Labels for the hybrid inverters:

<p style="text-align: center;"><b>GOODWE</b></p> <p><b>Product: Hybrid Inverter</b> <b>Model: GW5K-ETA-G20</b></p> <table border="1"> <tr> <td colspan="2"><b>PV</b></td> </tr> <tr> <td>Max. Input Voltage</td> <td>1000Vd.c.</td> </tr> <tr> <td>MPPT Operating Voltage Range</td> <td>120...950Vd.c.</td> </tr> <tr> <td>Max. MPPT Current</td> <td>21/21/21Ad.c.</td> </tr> <tr> <td>Max. MPPT Short Circuit Current</td> <td>26/26/26Ad.c.</td> </tr> <tr> <td colspan="2"><b>Battery</b></td> </tr> <tr> <td>Battery Voltage Range</td> <td>700...950Vd.c.</td> </tr> <tr> <td>Max. Continuous Charging Current</td> <td>6.7Ad.c.</td> </tr> <tr> <td>Max. Continuous Discharging Current</td> <td>7.4Ad.c.</td> </tr> <tr> <td>Battery Type</td> <td>LHOn</td> </tr> <tr> <td colspan="2"><b>On-grid</b></td> </tr> <tr> <td>Nominal Voltage</td> <td>3L/N/PE~220/380, 230/400Va.c.</td> </tr> <tr> <td>Nominal Frequency</td> <td>50/60Hz</td> </tr> <tr> <td>Rated Power</td> <td>5kW</td> </tr> <tr> <td>Rated Apparent Power to Grid</td> <td>5kVA</td> </tr> <tr> <td>Max. Apparent Power to Grid</td> <td>5kVA</td> </tr> <tr> <td>Rated Current to Grid</td> <td>7.6A@380Va.c. 7.3A@400Va.c.</td> </tr> <tr> <td>Max. Current to Grid</td> <td>7.6A@380Va.c. 7.3A@400Va.c.</td> </tr> <tr> <td>Rated Apparent Power from Grid</td> <td>5kVA</td> </tr> <tr> <td>Max. Apparent Power from Grid</td> <td>43.5kVA</td> </tr> <tr> <td>Rated Current from Grid</td> <td>7.6A@380Va.c. 7.3A@400Va.c.</td> </tr> <tr> <td>Max. Current from Grid</td> <td>63.0Ad.c.</td> </tr> <tr> <td>Power Factor</td> <td>0.8lagging...0.8leading</td> </tr> <tr> <td colspan="2"><b>Back-up</b></td> </tr> <tr> <td>Nominal Output Voltage</td> <td>3L/N/PE~220/380, 230/400Va.c.</td> </tr> <tr> <td>Nominal Output Frequency</td> <td>50/60Hz</td> </tr> <tr> <td>Rated Output Current</td> <td>7.6A@380Va.c. 7.3A@400Va.c.</td> </tr> <tr> <td>Max. Output Current</td> <td>11.4Aa.c. (off grid) 63.0Aa.c. (on grid)</td> </tr> <tr> <td>Rated Output Apparent Power</td> <td>5kVA</td> </tr> <tr> <td>Max. Output Apparent Power</td> <td>5.5kVA (off grid) 43.5kVA (on grid)</td> </tr> <tr> <td colspan="2"><b>General Data</b></td> </tr> <tr> <td>Operating Temperature Range</td> <td>-35...+60°C</td> </tr> <tr> <td colspan="2">Non-Isolated, IP66, Protective Class: I, OVC: DC II/AC III</td> </tr> <tr> <td colspan="2" style="text-align: center;">   </td> </tr> <tr> <td colspan="2">                     GoodWe Technologies Co., Ltd.                      service@goodwe.com                      No.90 Zjin Rd., New District, Suzhou, 215011, China                 </td> </tr> <tr> <td colspan="2" style="text-align: right;">  </td> </tr> </table>	<b>PV</b>		Max. Input Voltage	1000Vd.c.	MPPT Operating Voltage Range	120...950Vd.c.	Max. MPPT Current	21/21/21Ad.c.	Max. MPPT Short Circuit Current	26/26/26Ad.c.	<b>Battery</b>		Battery Voltage Range	700...950Vd.c.	Max. Continuous Charging Current	6.7Ad.c.	Max. Continuous Discharging Current	7.4Ad.c.	Battery Type	LHOn	<b>On-grid</b>		Nominal Voltage	3L/N/PE~220/380, 230/400Va.c.	Nominal Frequency	50/60Hz	Rated Power	5kW	Rated Apparent Power to Grid	5kVA	Max. Apparent Power to Grid	5kVA	Rated Current to Grid	7.6A@380Va.c. 7.3A@400Va.c.	Max. Current to Grid	7.6A@380Va.c. 7.3A@400Va.c.	Rated Apparent Power from Grid	5kVA	Max. Apparent Power from Grid	43.5kVA	Rated Current from Grid	7.6A@380Va.c. 7.3A@400Va.c.	Max. Current from Grid	63.0Ad.c.	Power Factor	0.8lagging...0.8leading	<b>Back-up</b>		Nominal Output Voltage	3L/N/PE~220/380, 230/400Va.c.	Nominal Output Frequency	50/60Hz	Rated Output Current	7.6A@380Va.c. 7.3A@400Va.c.	Max. Output Current	11.4Aa.c. (off grid) 63.0Aa.c. (on grid)	Rated Output Apparent Power	5kVA	Max. Output Apparent Power	5.5kVA (off grid) 43.5kVA (on grid)	<b>General Data</b>		Operating Temperature Range	-35...+60°C	Non-Isolated, IP66, Protective Class: I, OVC: DC II/AC III		 		GoodWe Technologies Co., Ltd. service@goodwe.com No.90 Zjin Rd., New District, Suzhou, 215011, China				<p style="text-align: center;"><b>GOODWE</b></p> <p><b>Product: Hybrid Inverter</b> <b>Model: GW6K-ETA-G20</b></p> <table border="1"> <tr> <td colspan="2"><b>PV</b></td> </tr> <tr> <td>Max. Input Voltage</td> <td>1000Vd.c.</td> </tr> <tr> <td>MPPT Operating Voltage Range</td> <td>120...950Vd.c.</td> </tr> <tr> <td>Max. MPPT Current</td> <td>21/21/21Ad.c.</td> </tr> <tr> <td>Max. MPPT Short Circuit Current</td> <td>26/26/26Ad.c.</td> </tr> <tr> <td colspan="2"><b>Battery</b></td> </tr> <tr> <td>Battery Voltage Range</td> <td>700...950Vd.c.</td> </tr> <tr> <td>Max. Continuous Charging Current</td> <td>8.1Ad.c.</td> </tr> <tr> <td>Max. Continuous Discharging Current</td> <td>8.9Ad.c.</td> </tr> <tr> <td>Battery Type</td> <td>LHOn</td> </tr> <tr> <td colspan="2"><b>On-grid</b></td> </tr> <tr> <td>Nominal Voltage</td> <td>3L/N/PE~220/380, 230/400Va.c.</td> </tr> <tr> <td>Nominal Frequency</td> <td>50/60Hz</td> </tr> <tr> <td>Rated Power</td> <td>6kW</td> </tr> <tr> <td>Rated Apparent Power to Grid</td> <td>6kVA</td> </tr> <tr> <td>Max. Apparent Power to Grid</td> <td>6kVA</td> </tr> <tr> <td>Rated Current to Grid</td> <td>9.1A@380Va.c. 8.7A@400Va.c.</td> </tr> <tr> <td>Max. Current to Grid</td> <td>9.1A@380Va.c. 8.7A@400Va.c.</td> </tr> <tr> <td>Rated Apparent Power from Grid</td> <td>6kVA</td> </tr> <tr> <td>Max. Apparent Power from Grid</td> <td>43.5kVA</td> </tr> <tr> <td>Rated Current from Grid</td> <td>9.1A@380Va.c. 8.7A@400Va.c.</td> </tr> <tr> <td>Max. Current from Grid</td> <td>63.0Ad.c.</td> </tr> <tr> <td>Power Factor</td> <td>0.8lagging...0.8leading</td> </tr> <tr> <td colspan="2"><b>Back-up</b></td> </tr> <tr> <td>Nominal Output Voltage</td> <td>3L/N/PE~220/380, 230/400Va.c.</td> </tr> <tr> <td>Nominal Output Frequency</td> <td>50/60Hz</td> </tr> <tr> <td>Rated Output Current</td> <td>9.1A@380Va.c. 8.7A@400Va.c.</td> </tr> <tr> <td>Max. Output Current</td> <td>13.7Aa.c. (off grid) 63.0Aa.c. (on grid)</td> </tr> <tr> <td>Rated Output Apparent Power</td> <td>6kVA</td> </tr> <tr> <td>Max. Output Apparent Power</td> <td>6.6kVA (off grid) 43.5kVA (on grid)</td> </tr> <tr> <td colspan="2"><b>General Data</b></td> </tr> <tr> <td>Operating Temperature Range</td> <td>-35...+60°C</td> </tr> <tr> <td colspan="2">Non-Isolated, IP66, Protective Class: I, OVC: DC II/AC III</td> </tr> <tr> <td colspan="2" style="text-align: center;">   </td> </tr> <tr> <td colspan="2">                     GoodWe Technologies Co., Ltd.                      service@goodwe.com                      No.90 Zjin Rd., New District, Suzhou, 215011, China                 </td> </tr> <tr> <td colspan="2" style="text-align: right;">  </td> </tr> </table>	<b>PV</b>		Max. Input Voltage	1000Vd.c.	MPPT Operating Voltage Range	120...950Vd.c.	Max. MPPT Current	21/21/21Ad.c.	Max. MPPT Short Circuit Current	26/26/26Ad.c.	<b>Battery</b>		Battery Voltage Range	700...950Vd.c.	Max. Continuous Charging Current	8.1Ad.c.	Max. Continuous Discharging Current	8.9Ad.c.	Battery Type	LHOn	<b>On-grid</b>		Nominal Voltage	3L/N/PE~220/380, 230/400Va.c.	Nominal Frequency	50/60Hz	Rated Power	6kW	Rated Apparent Power to Grid	6kVA	Max. Apparent Power to Grid	6kVA	Rated Current to Grid	9.1A@380Va.c. 8.7A@400Va.c.	Max. Current to Grid	9.1A@380Va.c. 8.7A@400Va.c.	Rated Apparent Power from Grid	6kVA	Max. Apparent Power from Grid	43.5kVA	Rated Current from Grid	9.1A@380Va.c. 8.7A@400Va.c.	Max. Current from Grid	63.0Ad.c.	Power Factor	0.8lagging...0.8leading	<b>Back-up</b>		Nominal Output Voltage	3L/N/PE~220/380, 230/400Va.c.	Nominal Output Frequency	50/60Hz	Rated Output Current	9.1A@380Va.c. 8.7A@400Va.c.	Max. Output Current	13.7Aa.c. (off grid) 63.0Aa.c. (on grid)	Rated Output Apparent Power	6kVA	Max. Output Apparent Power	6.6kVA (off grid) 43.5kVA (on grid)	<b>General Data</b>		Operating Temperature Range	-35...+60°C	Non-Isolated, IP66, Protective Class: I, OVC: DC II/AC III		 		GoodWe Technologies Co., Ltd. service@goodwe.com No.90 Zjin Rd., New District, Suzhou, 215011, China				<p style="text-align: center;"><b>GOODWE</b></p> <p><b>Product: Hybrid Inverter</b> <b>Model: GW8K-ETA-G20</b></p> <table border="1"> <tr> <td colspan="2"><b>PV</b></td> </tr> <tr> <td>Max. Input Voltage</td> <td>1000Vd.c.</td> </tr> <tr> <td>MPPT Operating Voltage Range</td> <td>120...950Vd.c.</td> </tr> <tr> <td>Max. MPPT Current</td> <td>21/21/21Ad.c.</td> </tr> <tr> <td>Max. MPPT Short Circuit Current</td> <td>26/26/26Ad.c.</td> </tr> <tr> <td colspan="2"><b>Battery</b></td> </tr> <tr> <td>Battery Voltage Range</td> <td>700...950Vd.c.</td> </tr> <tr> <td>Max. Continuous Charging Current</td> <td>10.7Ad.c.</td> </tr> <tr> <td>Max. Continuous Discharging Current</td> <td>11.8Ad.c.</td> </tr> <tr> <td>Battery Type</td> <td>LHOn</td> </tr> <tr> <td colspan="2"><b>On-grid</b></td> </tr> <tr> <td>Nominal Voltage</td> <td>3L/N/PE~220/380, 230/400Va.c.</td> </tr> <tr> <td>Nominal Frequency</td> <td>50/60Hz</td> </tr> <tr> <td>Rated Power</td> <td>8kW</td> </tr> <tr> <td>Rated Apparent Power to Grid</td> <td>8kVA</td> </tr> <tr> <td>Max. Apparent Power to Grid</td> <td>8kVA</td> </tr> <tr> <td>Rated Current to Grid</td> <td>12.2A@380Va.c. 11.6A@400Va.c.</td> </tr> <tr> <td>Max. Current to Grid</td> <td>12.2A@380Va.c. 11.6A@400Va.c.</td> </tr> <tr> <td>Rated Apparent Power from Grid</td> <td>8kVA</td> </tr> <tr> <td>Max. Apparent Power from Grid</td> <td>43.5kVA</td> </tr> <tr> <td>Rated Current from Grid</td> <td>12.2A@380Va.c. 11.6A@400Va.c.</td> </tr> <tr> <td>Max. Current from Grid</td> <td>63.0Ad.c.</td> </tr> <tr> <td>Power Factor</td> <td>0.8lagging...0.8leading</td> </tr> <tr> <td colspan="2"><b>Back-up</b></td> </tr> <tr> <td>Nominal Output Voltage</td> <td>3L/N/PE~220/380, 230/400Va.c.</td> </tr> <tr> <td>Nominal Output Frequency</td> <td>50/60Hz</td> </tr> <tr> <td>Rated Output Current</td> <td>12.2A@380Va.c. 11.6A@400Va.c.</td> </tr> <tr> <td>Max. Output Current</td> <td>18.2Aa.c. (off grid) 63.0Aa.c. (on grid)</td> </tr> <tr> <td>Rated Output Apparent Power</td> <td>8kVA</td> </tr> <tr> <td>Max. Output Apparent Power</td> <td>8.8kVA (off grid) 43.5kVA (on grid)</td> </tr> <tr> <td colspan="2"><b>General Data</b></td> </tr> <tr> <td>Operating Temperature Range</td> <td>-35...+60°C</td> </tr> <tr> <td colspan="2">Non-Isolated, IP66, Protective Class: I, OVC: DC II/AC III</td> </tr> <tr> <td colspan="2" style="text-align: center;">   </td> </tr> <tr> <td colspan="2">                     GoodWe Technologies Co., Ltd.                      service@goodwe.com                      No.90 Zjin Rd., New District, Suzhou, 215011, China                 </td> </tr> <tr> <td colspan="2" style="text-align: right;">  </td> </tr> </table>	<b>PV</b>		Max. Input Voltage	1000Vd.c.	MPPT Operating Voltage Range	120...950Vd.c.	Max. MPPT Current	21/21/21Ad.c.	Max. MPPT Short Circuit Current	26/26/26Ad.c.	<b>Battery</b>		Battery Voltage Range	700...950Vd.c.	Max. Continuous Charging Current	10.7Ad.c.	Max. Continuous Discharging Current	11.8Ad.c.	Battery Type	LHOn	<b>On-grid</b>		Nominal Voltage	3L/N/PE~220/380, 230/400Va.c.	Nominal Frequency	50/60Hz	Rated Power	8kW	Rated Apparent Power to Grid	8kVA	Max. Apparent Power to Grid	8kVA	Rated Current to Grid	12.2A@380Va.c. 11.6A@400Va.c.	Max. Current to Grid	12.2A@380Va.c. 11.6A@400Va.c.	Rated Apparent Power from Grid	8kVA	Max. Apparent Power from Grid	43.5kVA	Rated Current from Grid	12.2A@380Va.c. 11.6A@400Va.c.	Max. Current from Grid	63.0Ad.c.	Power Factor	0.8lagging...0.8leading	<b>Back-up</b>		Nominal Output Voltage	3L/N/PE~220/380, 230/400Va.c.	Nominal Output Frequency	50/60Hz	Rated Output Current	12.2A@380Va.c. 11.6A@400Va.c.	Max. Output Current	18.2Aa.c. (off grid) 63.0Aa.c. (on grid)	Rated Output Apparent Power	8kVA	Max. Output Apparent Power	8.8kVA (off grid) 43.5kVA (on grid)	<b>General Data</b>		Operating Temperature Range	-35...+60°C	Non-Isolated, IP66, Protective Class: I, OVC: DC II/AC III		 		GoodWe Technologies Co., Ltd. service@goodwe.com No.90 Zjin Rd., New District, Suzhou, 215011, China			
<b>PV</b>																																																																																																																																																																																																																										
Max. Input Voltage	1000Vd.c.																																																																																																																																																																																																																									
MPPT Operating Voltage Range	120...950Vd.c.																																																																																																																																																																																																																									
Max. MPPT Current	21/21/21Ad.c.																																																																																																																																																																																																																									
Max. MPPT Short Circuit Current	26/26/26Ad.c.																																																																																																																																																																																																																									
<b>Battery</b>																																																																																																																																																																																																																										
Battery Voltage Range	700...950Vd.c.																																																																																																																																																																																																																									
Max. Continuous Charging Current	6.7Ad.c.																																																																																																																																																																																																																									
Max. Continuous Discharging Current	7.4Ad.c.																																																																																																																																																																																																																									
Battery Type	LHOn																																																																																																																																																																																																																									
<b>On-grid</b>																																																																																																																																																																																																																										
Nominal Voltage	3L/N/PE~220/380, 230/400Va.c.																																																																																																																																																																																																																									
Nominal Frequency	50/60Hz																																																																																																																																																																																																																									
Rated Power	5kW																																																																																																																																																																																																																									
Rated Apparent Power to Grid	5kVA																																																																																																																																																																																																																									
Max. Apparent Power to Grid	5kVA																																																																																																																																																																																																																									
Rated Current to Grid	7.6A@380Va.c. 7.3A@400Va.c.																																																																																																																																																																																																																									
Max. Current to Grid	7.6A@380Va.c. 7.3A@400Va.c.																																																																																																																																																																																																																									
Rated Apparent Power from Grid	5kVA																																																																																																																																																																																																																									
Max. Apparent Power from Grid	43.5kVA																																																																																																																																																																																																																									
Rated Current from Grid	7.6A@380Va.c. 7.3A@400Va.c.																																																																																																																																																																																																																									
Max. Current from Grid	63.0Ad.c.																																																																																																																																																																																																																									
Power Factor	0.8lagging...0.8leading																																																																																																																																																																																																																									
<b>Back-up</b>																																																																																																																																																																																																																										
Nominal Output Voltage	3L/N/PE~220/380, 230/400Va.c.																																																																																																																																																																																																																									
Nominal Output Frequency	50/60Hz																																																																																																																																																																																																																									
Rated Output Current	7.6A@380Va.c. 7.3A@400Va.c.																																																																																																																																																																																																																									
Max. Output Current	11.4Aa.c. (off grid) 63.0Aa.c. (on grid)																																																																																																																																																																																																																									
Rated Output Apparent Power	5kVA																																																																																																																																																																																																																									
Max. Output Apparent Power	5.5kVA (off grid) 43.5kVA (on grid)																																																																																																																																																																																																																									
<b>General Data</b>																																																																																																																																																																																																																										
Operating Temperature Range	-35...+60°C																																																																																																																																																																																																																									
Non-Isolated, IP66, Protective Class: I, OVC: DC II/AC III																																																																																																																																																																																																																										
 																																																																																																																																																																																																																										
GoodWe Technologies Co., Ltd. service@goodwe.com No.90 Zjin Rd., New District, Suzhou, 215011, China																																																																																																																																																																																																																										
																																																																																																																																																																																																																										
<b>PV</b>																																																																																																																																																																																																																										
Max. Input Voltage	1000Vd.c.																																																																																																																																																																																																																									
MPPT Operating Voltage Range	120...950Vd.c.																																																																																																																																																																																																																									
Max. MPPT Current	21/21/21Ad.c.																																																																																																																																																																																																																									
Max. MPPT Short Circuit Current	26/26/26Ad.c.																																																																																																																																																																																																																									
<b>Battery</b>																																																																																																																																																																																																																										
Battery Voltage Range	700...950Vd.c.																																																																																																																																																																																																																									
Max. Continuous Charging Current	8.1Ad.c.																																																																																																																																																																																																																									
Max. Continuous Discharging Current	8.9Ad.c.																																																																																																																																																																																																																									
Battery Type	LHOn																																																																																																																																																																																																																									
<b>On-grid</b>																																																																																																																																																																																																																										
Nominal Voltage	3L/N/PE~220/380, 230/400Va.c.																																																																																																																																																																																																																									
Nominal Frequency	50/60Hz																																																																																																																																																																																																																									
Rated Power	6kW																																																																																																																																																																																																																									
Rated Apparent Power to Grid	6kVA																																																																																																																																																																																																																									
Max. Apparent Power to Grid	6kVA																																																																																																																																																																																																																									
Rated Current to Grid	9.1A@380Va.c. 8.7A@400Va.c.																																																																																																																																																																																																																									
Max. Current to Grid	9.1A@380Va.c. 8.7A@400Va.c.																																																																																																																																																																																																																									
Rated Apparent Power from Grid	6kVA																																																																																																																																																																																																																									
Max. Apparent Power from Grid	43.5kVA																																																																																																																																																																																																																									
Rated Current from Grid	9.1A@380Va.c. 8.7A@400Va.c.																																																																																																																																																																																																																									
Max. Current from Grid	63.0Ad.c.																																																																																																																																																																																																																									
Power Factor	0.8lagging...0.8leading																																																																																																																																																																																																																									
<b>Back-up</b>																																																																																																																																																																																																																										
Nominal Output Voltage	3L/N/PE~220/380, 230/400Va.c.																																																																																																																																																																																																																									
Nominal Output Frequency	50/60Hz																																																																																																																																																																																																																									
Rated Output Current	9.1A@380Va.c. 8.7A@400Va.c.																																																																																																																																																																																																																									
Max. Output Current	13.7Aa.c. (off grid) 63.0Aa.c. (on grid)																																																																																																																																																																																																																									
Rated Output Apparent Power	6kVA																																																																																																																																																																																																																									
Max. Output Apparent Power	6.6kVA (off grid) 43.5kVA (on grid)																																																																																																																																																																																																																									
<b>General Data</b>																																																																																																																																																																																																																										
Operating Temperature Range	-35...+60°C																																																																																																																																																																																																																									
Non-Isolated, IP66, Protective Class: I, OVC: DC II/AC III																																																																																																																																																																																																																										
 																																																																																																																																																																																																																										
GoodWe Technologies Co., Ltd. service@goodwe.com No.90 Zjin Rd., New District, Suzhou, 215011, China																																																																																																																																																																																																																										
																																																																																																																																																																																																																										
<b>PV</b>																																																																																																																																																																																																																										
Max. Input Voltage	1000Vd.c.																																																																																																																																																																																																																									
MPPT Operating Voltage Range	120...950Vd.c.																																																																																																																																																																																																																									
Max. MPPT Current	21/21/21Ad.c.																																																																																																																																																																																																																									
Max. MPPT Short Circuit Current	26/26/26Ad.c.																																																																																																																																																																																																																									
<b>Battery</b>																																																																																																																																																																																																																										
Battery Voltage Range	700...950Vd.c.																																																																																																																																																																																																																									
Max. Continuous Charging Current	10.7Ad.c.																																																																																																																																																																																																																									
Max. Continuous Discharging Current	11.8Ad.c.																																																																																																																																																																																																																									
Battery Type	LHOn																																																																																																																																																																																																																									
<b>On-grid</b>																																																																																																																																																																																																																										
Nominal Voltage	3L/N/PE~220/380, 230/400Va.c.																																																																																																																																																																																																																									
Nominal Frequency	50/60Hz																																																																																																																																																																																																																									
Rated Power	8kW																																																																																																																																																																																																																									
Rated Apparent Power to Grid	8kVA																																																																																																																																																																																																																									
Max. Apparent Power to Grid	8kVA																																																																																																																																																																																																																									
Rated Current to Grid	12.2A@380Va.c. 11.6A@400Va.c.																																																																																																																																																																																																																									
Max. Current to Grid	12.2A@380Va.c. 11.6A@400Va.c.																																																																																																																																																																																																																									
Rated Apparent Power from Grid	8kVA																																																																																																																																																																																																																									
Max. Apparent Power from Grid	43.5kVA																																																																																																																																																																																																																									
Rated Current from Grid	12.2A@380Va.c. 11.6A@400Va.c.																																																																																																																																																																																																																									
Max. Current from Grid	63.0Ad.c.																																																																																																																																																																																																																									
Power Factor	0.8lagging...0.8leading																																																																																																																																																																																																																									
<b>Back-up</b>																																																																																																																																																																																																																										
Nominal Output Voltage	3L/N/PE~220/380, 230/400Va.c.																																																																																																																																																																																																																									
Nominal Output Frequency	50/60Hz																																																																																																																																																																																																																									
Rated Output Current	12.2A@380Va.c. 11.6A@400Va.c.																																																																																																																																																																																																																									
Max. Output Current	18.2Aa.c. (off grid) 63.0Aa.c. (on grid)																																																																																																																																																																																																																									
Rated Output Apparent Power	8kVA																																																																																																																																																																																																																									
Max. Output Apparent Power	8.8kVA (off grid) 43.5kVA (on grid)																																																																																																																																																																																																																									
<b>General Data</b>																																																																																																																																																																																																																										
Operating Temperature Range	-35...+60°C																																																																																																																																																																																																																									
Non-Isolated, IP66, Protective Class: I, OVC: DC II/AC III																																																																																																																																																																																																																										
 																																																																																																																																																																																																																										
GoodWe Technologies Co., Ltd. service@goodwe.com No.90 Zjin Rd., New District, Suzhou, 215011, China																																																																																																																																																																																																																										
																																																																																																																																																																																																																										

<p><b>GOODWE</b>  <b>Product: Hybrid Inverter</b>  <b>Model: GW9.999K-ETA-G20</b></p> <p><b>PV</b>                      Max. Input Voltage 1000Vd.c.                      MPPT Operating Voltage Range 120...950Vd.c.                      Max. MPPT Current 21/21/21/21Ad.c.                      Max. MPPT Short Circuit Current 26/26/26/26Ad.c.</p> <p><b>Battery</b>                      Battery Voltage Range 700...950Vd.c.                      Max. Continuous Charging Current 13.4Ad.c.                      Max. Continuous Discharging Current 14.7Ad.c.                      Battery Type L/Hon</p> <p><b>On-grid</b>                      Nominal Voltage 3L/N/PE-220/380, 230/400Va.c.                      Nominal Frequency 50/60Hz                      Rated Power 9.999kW                      Rated Apparent Power to Grid 9.999kVA                      Max. Apparent Power to Grid 9.999kVA                      Rated Current to Grid 15.2A@380Va.c.                      14.5A@400Va.c.                      Max. Current to Grid 15.2A@380Va.c.                      14.5A@400Va.c.                      Rated Apparent Power from Grid 9.999kVA                      Max. Apparent Power from Grid 43.5kVA                      Rated Current from Grid 15.2A@380Va.c.                      14.5A@400Va.c.                      Max. Current from Grid 63.0Ad.c.                      Power Factor 0.8lagging...0.8leading</p> <p><b>Back-up</b>                      Nominal Output Voltage 3L/N/PE-220/380, 230/400Va.c.                      Nominal Output Frequency 50/60Hz                      Rated Output Current 15.2A@380Va.c.                      14.5A@400Va.c.                      Max. Output Current 22.8Aa.c. (off grid)                      63.0Aa.c. (on grid)                      Rated Output Apparent Power 10kVA                      Max. Output Apparent Power 11.0kVA (off grid)                      43.5kVA (on grid)</p> <p><b>General Data</b>                      Operating Temperature Range -35...+60°C                      Non-isolated, IP66, Protective Class: I, OVC: DC II/AC III</p> <p> </p> <p>GoodWe Technologies Co., Ltd.                      service@goodwe.com                      No.90 Zjin Rd., New District, Suzhou, 215011, China <b>QC PASS</b></p>	<p><b>GOODWE</b>  <b>Product: Hybrid Inverter</b>  <b>Model: GW10K-ETA-G20</b></p> <p><b>PV</b>                      Max. Input Voltage 1000Vd.c.                      MPPT Operating Voltage Range 120...950Vd.c.                      Max. MPPT Current 21/21/21/21Ad.c.                      Max. MPPT Short Circuit Current 26/26/26/26Ad.c.</p> <p><b>Battery</b>                      Battery Voltage Range 700...950Vd.c.                      Max. Continuous Charging Current 13.4Ad.c.                      Max. Continuous Discharging Current 14.7Ad.c.                      Battery Type L/Hon</p> <p><b>On-grid</b>                      Nominal Voltage 3L/N/PE-220/380, 230/400Va.c.                      Nominal Frequency 50/60Hz                      Rated Power 10kW                      Rated Apparent Power to Grid 10kVA                      Max. Apparent Power to Grid 10kVA                      Rated Current to Grid 15.2A@380Va.c.                      14.5A@400Va.c.                      Max. Current to Grid 15.2A@380Va.c.                      14.5A@400Va.c.                      Rated Apparent Power from Grid 10kVA                      Max. Apparent Power from Grid 43.5kVA                      Rated Current from Grid 15.2A@380Va.c.                      14.5A@400Va.c.                      Max. Current from Grid 63.0Ad.c.                      Power Factor 0.8lagging...0.8leading</p> <p><b>Back-up</b>                      Nominal Output Voltage 3L/N/PE-220/380, 230/400Va.c.                      Nominal Output Frequency 50/60Hz                      Rated Output Current 15.2A@380Va.c.                      14.5A@400Va.c.                      Max. Output Current 22.8Aa.c. (off grid)                      63.0Aa.c. (on grid)                      Rated Output Apparent Power 10kVA                      Max. Output Apparent Power 11.0kVA (off grid)                      43.5kVA (on grid)</p> <p><b>General Data</b>                      Operating Temperature Range -35...+60°C                      Non-isolated, IP66, Protective Class: I, OVC: DC II/AC III</p> <p> </p> <p>GoodWe Technologies Co., Ltd.                      service@goodwe.com                      No.90 Zjin Rd., New District, Suzhou, 215011, China <b>QC PASS</b></p>	<p><b>GOODWE</b>  <b>Product: Hybrid Inverter</b>  <b>Model: GW12K-ETA-G20</b></p> <p><b>PV</b>                      Max. Input Voltage 1000Vd.c.                      MPPT Operating Voltage Range 120...950Vd.c.                      Max. MPPT Current 21/21/21/21Ad.c.                      Max. MPPT Short Circuit Current 26/26/26/26Ad.c.</p> <p><b>Battery</b>                      Battery Voltage Range 700...950Vd.c.                      Max. Continuous Charging Current 16.1Ad.c.                      Max. Continuous Discharging Current 17.7Ad.c.                      Battery Type L/Hon</p> <p><b>On-grid</b>                      Nominal Voltage 3L/N/PE-220/380, 230/400Va.c.                      Nominal Frequency 50/60Hz                      Rated Power 12kW                      Rated Apparent Power to Grid 12kVA                      Max. Apparent Power to Grid 12kVA                      Rated Current to Grid 18.2A@380Va.c.                      17.4A@400Va.c.                      Max. Current to Grid 18.2A@380Va.c.                      17.4A@400Va.c.                      Rated Apparent Power from Grid 12kVA                      Max. Apparent Power from Grid 43.5kVA                      Rated Current from Grid 18.2A@380Va.c.                      17.4A@400Va.c.                      Max. Current from Grid 63.0Ad.c.                      Power Factor 0.8lagging...0.8leading</p> <p><b>Back-up</b>                      Nominal Output Voltage 3L/N/PE-220/380, 230/400Va.c.                      Nominal Output Frequency 50/60Hz                      Rated Output Current 18.2A@380Va.c.                      17.4A@400Va.c.                      Max. Output Current 27.3Aa.c. (off grid)                      63.0Aa.c. (on grid)                      Rated Output Apparent Power 12kVA                      Max. Output Apparent Power 13.2kVA (off grid)                      43.5kVA (on grid)</p> <p><b>General Data</b>                      Operating Temperature Range -35...+60°C                      Non-isolated, IP66, Protective Class: I, OVC: DC II/AC III</p> <p> </p> <p>GoodWe Technologies Co., Ltd.                      service@goodwe.com                      No.90 Zjin Rd., New District, Suzhou, 215011, China <b>QC PASS</b></p>
--	---	---

<b>GOODWE</b> <b>Product: Hybrid Inverter</b> <b>Model: GW15K-ETA-G20</b>	<b>GOODWE</b> <b>Product: Hybrid Inverter</b> <b>Model: GW20K-ETA-G20</b>	<b>GOODWE</b> <b>Product: Hybrid Inverter</b> <b>Model: GW25K-ETA-G20</b>
<b>PV</b> Max. Input Voltage 1000Vd.c. MPPT Operating Voltage Range 120...950Vd.c. Max. MPPT Current 21/21/21/21Ad.c. Max. MPPT Short Circuit Current 26/26/26/26Ad.c.	<b>PV</b> Max. Input Voltage 1000Vd.c. MPPT Operating Voltage Range 120...950Vd.c. Max. MPPT Current 21/21/21/21Ad.c. Max. MPPT Short Circuit Current 26/26/26/26Ad.c.	<b>PV</b> Max. Input Voltage 1000Vd.c. MPPT Operating Voltage Range 120...950Vd.c. Max. MPPT Current 21/21/21/21Ad.c. Max. MPPT Short Circuit Current 26/26/26/26Ad.c.
<b>Battery</b> Battery Voltage Range 700...950Vd.c. Max. Continuous Charging Current 20.1Ad.c. Max. Continuous Discharging Current 22.1Ad.c. Battery Type L/Hon	<b>Battery</b> Battery Voltage Range 700...950Vd.c. Max. Continuous Charging Current 26.7Ad.c. Max. Continuous Discharging Current 29.4Ad.c. Battery Type L/Hon	<b>Battery</b> Battery Voltage Range 700...950Vd.c. Max. Continuous Charging Current 33.3Ad.c. Max. Continuous Discharging Current 36.7Ad.c. Battery Type L/Hon
<b>On-grid</b> Nominal Voltage 3LN/PE-220/380, 230/400Va.c. Nominal Frequency 50/60Hz Rated Power 15kW Rated Apparent Power to Grid 15kVA Max. Apparent Power to Grid 15kVA Rated Current to Grid 22.8A@380Va.c. 21.8A@400Va.c. Max. Current to Grid 22.8A@380Va.c. 21.8A@400Va.c. Rated Apparent Power from Grid 15kVA Max. Apparent Power from Grid 43.5kVA Rated Current from Grid 22.8A@380Va.c. 21.8A@400Va.c. Max. Current from Grid 63.0Ad.c. Power Factor 0.8lagging...0.8leading	<b>On-grid</b> Nominal Voltage 3LN/PE-220/380, 230/400Va.c. Nominal Frequency 50/60Hz Rated Power 20kW Rated Apparent Power to Grid 20kVA Max. Apparent Power to Grid 20kVA Rated Current to Grid 30.4A@380Va.c. 29.0A@400Va.c. Max. Current to Grid 30.4A@380Va.c. 29.0A@400Va.c. Rated Apparent Power from Grid 20kVA Max. Apparent Power from Grid 43.5kVA Rated Current from Grid 30.4A@380Va.c. 29.0A@400Va.c. Max. Current from Grid 63.0Ad.c. Power Factor 0.8lagging...0.8leading	<b>On-grid</b> Nominal Voltage 3LN/PE-220/380, 230/400Va.c. Nominal Frequency 50/60Hz Rated Power 25kW Rated Apparent Power to Grid 25kVA Max. Apparent Power to Grid 25kVA Rated Current to Grid 37.9A@380Va.c. 36.3A@400Va.c. Max. Current to Grid 37.9A@380Va.c. 36.3A@400Va.c. Rated Apparent Power from Grid 25kVA Max. Apparent Power from Grid 55.2kVA Rated Current from Grid 37.9A@380Va.c. 36.3A@400Va.c. Max. Current from Grid 80.0Aa.c. Power Factor 0.8lagging...0.8leading
<b>Back-up</b> Nominal Output Voltage 3LN/PE-220/380, 230/400Va.c. Nominal Output Frequency 50/60Hz Rated Output Current 22.8A@380Va.c. 21.8A@400Va.c. Max. Output Current 33.4Aa.c. (off grid) 63.0Aa.c. (on grid) Rated Output Apparent Power 15kVA Max. Output Apparent Power 16.5kVA (off grid) 43.5kVA (on grid)	<b>Back-up</b> Nominal Output Voltage 3LN/PE-220/380, 230/400Va.c. Nominal Output Frequency 50/60Hz Rated Output Current 30.4A@380Va.c. 29.0A@400Va.c. Max. Output Current 33.4Aa.c. (off grid) 63.0Aa.c. (on grid) Rated Output Apparent Power 20kVA Max. Output Apparent Power 22.0kVA (off grid) 43.5kVA (on grid)	<b>Back-up</b> Nominal Output Voltage 3LN/PE-220/380, 230/400Va.c. Nominal Output Frequency 50/60Hz Rated Output Current 37.9A@380Va.c. 36.3A@400Va.c. Max. Output Current 50.0Aa.c. (off grid) 80.0Aa.c. (on grid) Rated Output Apparent Power 25kVA Max. Output Apparent Power 27.5kVA (off grid) 55.2kVA (on grid)
<b>General Data</b> Operating Temperature Range -35...+60°C Non-isolated, IP66, Protective Class: I, OVC, DC II/AC III	<b>General Data</b> Operating Temperature Range -35...+60°C Non-isolated, IP66, Protective Class: I, OVC, DC II/AC III	<b>General Data</b> Operating Temperature Range -35...+60°C Non-isolated, IP66, Protective Class: I, OVC, DC II/AC III
 	 	 
GoodWe Technologies Co., Ltd. service@goodwe.com No.90 Zjin Rd., New District, Suzhou, 215011, China <div style="float: right; border: 1px solid black; padding: 2px;">QC PASS</div>	GoodWe Technologies Co., Ltd. service@goodwe.com No.90 Zjin Rd., New District, Suzhou, 215011, China <div style="float: right; border: 1px solid black; padding: 2px;">QC PASS</div>	GoodWe Technologies Co., Ltd. service@goodwe.com No.90 Zjin Rd., New District, Suzhou, 215011, China <div style="float: right; border: 1px solid black; padding: 2px;">QC PASS</div>

 <p><b>Product: Hybrid Inverter</b> <b>Model: GW29.999K-ETA-G20</b></p>	 <p><b>Product: Hybrid Inverter</b> <b>Model: GW30K-ETA-G20</b></p>																																																
<p><b>PV</b></p> <table border="0"> <tr><td>Max. Input Voltage</td><td>1000Vd.c.</td></tr> <tr><td>MPPT Operating Voltage Range</td><td>120...950Vd.c.</td></tr> <tr><td>Max. MPPT Current</td><td>21/21/42/42Ad.c.</td></tr> <tr><td>Max. MPPT Short Circuit Current</td><td>26/26/52/52Ad.c.</td></tr> </table>	Max. Input Voltage	1000Vd.c.	MPPT Operating Voltage Range	120...950Vd.c.	Max. MPPT Current	21/21/42/42Ad.c.	Max. MPPT Short Circuit Current	26/26/52/52Ad.c.	<p><b>PV</b></p> <table border="0"> <tr><td>Max. Input Voltage</td><td>1000Vd.c.</td></tr> <tr><td>MPPT Operating Voltage Range</td><td>120...950Vd.c.</td></tr> <tr><td>Max. MPPT Current</td><td>21/21/42/42Ad.c.</td></tr> <tr><td>Max. MPPT Short Circuit Current</td><td>26/26/52/52Ad.c.</td></tr> </table>	Max. Input Voltage	1000Vd.c.	MPPT Operating Voltage Range	120...950Vd.c.	Max. MPPT Current	21/21/42/42Ad.c.	Max. MPPT Short Circuit Current	26/26/52/52Ad.c.																																
Max. Input Voltage	1000Vd.c.																																																
MPPT Operating Voltage Range	120...950Vd.c.																																																
Max. MPPT Current	21/21/42/42Ad.c.																																																
Max. MPPT Short Circuit Current	26/26/52/52Ad.c.																																																
Max. Input Voltage	1000Vd.c.																																																
MPPT Operating Voltage Range	120...950Vd.c.																																																
Max. MPPT Current	21/21/42/42Ad.c.																																																
Max. MPPT Short Circuit Current	26/26/52/52Ad.c.																																																
<p><b>Battery</b></p> <table border="0"> <tr><td>Battery Voltage Range</td><td>700...950Vd.c.</td></tr> <tr><td>Max. Continuous Charging Current</td><td>40.0Ad.c.</td></tr> <tr><td>Max. Continuous Discharging Current</td><td>44.1Ad.c.</td></tr> <tr><td>Battery Type</td><td>LHOn</td></tr> </table>	Battery Voltage Range	700...950Vd.c.	Max. Continuous Charging Current	40.0Ad.c.	Max. Continuous Discharging Current	44.1Ad.c.	Battery Type	LHOn	<p><b>Battery</b></p> <table border="0"> <tr><td>Battery Voltage Range</td><td>700...950Vd.c.</td></tr> <tr><td>Max. Continuous Charging Current</td><td>40.0Ad.c.</td></tr> <tr><td>Max. Continuous Discharging Current</td><td>44.1Ad.c.</td></tr> <tr><td>Battery Type</td><td>LHOn</td></tr> </table>	Battery Voltage Range	700...950Vd.c.	Max. Continuous Charging Current	40.0Ad.c.	Max. Continuous Discharging Current	44.1Ad.c.	Battery Type	LHOn																																
Battery Voltage Range	700...950Vd.c.																																																
Max. Continuous Charging Current	40.0Ad.c.																																																
Max. Continuous Discharging Current	44.1Ad.c.																																																
Battery Type	LHOn																																																
Battery Voltage Range	700...950Vd.c.																																																
Max. Continuous Charging Current	40.0Ad.c.																																																
Max. Continuous Discharging Current	44.1Ad.c.																																																
Battery Type	LHOn																																																
<p><b>On-grid</b></p> <table border="0"> <tr><td>Nominal Voltage</td><td>3L/N/PE-220/380, 230/400Va.c.</td></tr> <tr><td>Nominal Frequency</td><td>50/60Hz</td></tr> <tr><td>Rated Power</td><td>29.999kW</td></tr> <tr><td>Rated Apparent Power to Grid</td><td>29.999kVA</td></tr> <tr><td>Max. Apparent Power to Grid</td><td>29.999kVA</td></tr> <tr><td>Rated Current to Grid</td><td>45.5A@380Va.c. 43.5A@400Va.c.</td></tr> <tr><td>Max. Current to Grid</td><td>45.5A@380Va.c. 43.5A@400Va.c.</td></tr> <tr><td>Rated Apparent Power from Grid</td><td>29.999kVA</td></tr> <tr><td>Max. Apparent Power from Grid</td><td>55.2kVA</td></tr> <tr><td>Rated Current from Grid</td><td>45.5A@380Va.c. 43.5A@400Va.c.</td></tr> <tr><td>Max. Current from Grid</td><td>80.0Aa.c.</td></tr> <tr><td>Power Factor</td><td>0.8lagging...0.8leading</td></tr> </table>	Nominal Voltage	3L/N/PE-220/380, 230/400Va.c.	Nominal Frequency	50/60Hz	Rated Power	29.999kW	Rated Apparent Power to Grid	29.999kVA	Max. Apparent Power to Grid	29.999kVA	Rated Current to Grid	45.5A@380Va.c. 43.5A@400Va.c.	Max. Current to Grid	45.5A@380Va.c. 43.5A@400Va.c.	Rated Apparent Power from Grid	29.999kVA	Max. Apparent Power from Grid	55.2kVA	Rated Current from Grid	45.5A@380Va.c. 43.5A@400Va.c.	Max. Current from Grid	80.0Aa.c.	Power Factor	0.8lagging...0.8leading	<p><b>On-grid</b></p> <table border="0"> <tr><td>Nominal Voltage</td><td>3L/N/PE-220/380, 230/400Va.c.</td></tr> <tr><td>Nominal Frequency</td><td>50/60Hz</td></tr> <tr><td>Rated Power</td><td>30kW</td></tr> <tr><td>Rated Apparent Power to Grid</td><td>30kVA</td></tr> <tr><td>Max. Apparent Power to Grid</td><td>30kVA</td></tr> <tr><td>Rated Current to Grid</td><td>45.5A@380Va.c. 43.5A@400Va.c.</td></tr> <tr><td>Max. Current to Grid</td><td>45.5A@380Va.c. 43.5A@400Va.c.</td></tr> <tr><td>Rated Apparent Power from Grid</td><td>30kVA</td></tr> <tr><td>Max. Apparent Power from Grid</td><td>55.2kVA</td></tr> <tr><td>Rated Current from Grid</td><td>45.5A@380Va.c. 43.5A@400Va.c.</td></tr> <tr><td>Max. Current from Grid</td><td>80.0Aa.c.</td></tr> <tr><td>Power Factor</td><td>0.8lagging...0.8leading</td></tr> </table>	Nominal Voltage	3L/N/PE-220/380, 230/400Va.c.	Nominal Frequency	50/60Hz	Rated Power	30kW	Rated Apparent Power to Grid	30kVA	Max. Apparent Power to Grid	30kVA	Rated Current to Grid	45.5A@380Va.c. 43.5A@400Va.c.	Max. Current to Grid	45.5A@380Va.c. 43.5A@400Va.c.	Rated Apparent Power from Grid	30kVA	Max. Apparent Power from Grid	55.2kVA	Rated Current from Grid	45.5A@380Va.c. 43.5A@400Va.c.	Max. Current from Grid	80.0Aa.c.	Power Factor	0.8lagging...0.8leading
Nominal Voltage	3L/N/PE-220/380, 230/400Va.c.																																																
Nominal Frequency	50/60Hz																																																
Rated Power	29.999kW																																																
Rated Apparent Power to Grid	29.999kVA																																																
Max. Apparent Power to Grid	29.999kVA																																																
Rated Current to Grid	45.5A@380Va.c. 43.5A@400Va.c.																																																
Max. Current to Grid	45.5A@380Va.c. 43.5A@400Va.c.																																																
Rated Apparent Power from Grid	29.999kVA																																																
Max. Apparent Power from Grid	55.2kVA																																																
Rated Current from Grid	45.5A@380Va.c. 43.5A@400Va.c.																																																
Max. Current from Grid	80.0Aa.c.																																																
Power Factor	0.8lagging...0.8leading																																																
Nominal Voltage	3L/N/PE-220/380, 230/400Va.c.																																																
Nominal Frequency	50/60Hz																																																
Rated Power	30kW																																																
Rated Apparent Power to Grid	30kVA																																																
Max. Apparent Power to Grid	30kVA																																																
Rated Current to Grid	45.5A@380Va.c. 43.5A@400Va.c.																																																
Max. Current to Grid	45.5A@380Va.c. 43.5A@400Va.c.																																																
Rated Apparent Power from Grid	30kVA																																																
Max. Apparent Power from Grid	55.2kVA																																																
Rated Current from Grid	45.5A@380Va.c. 43.5A@400Va.c.																																																
Max. Current from Grid	80.0Aa.c.																																																
Power Factor	0.8lagging...0.8leading																																																
<p><b>Back-up</b></p> <table border="0"> <tr><td>Nominal Output Voltage</td><td>3L/N/PE-220/380, 230/400Va.c.</td></tr> <tr><td>Nominal Output Frequency</td><td>50/60Hz</td></tr> <tr><td>Rated Output Current</td><td>45.5A@380Va.c. 43.5A@400Va.c.</td></tr> <tr><td>Max. Output Current</td><td>50.0Aa.c. (off grid) 80.0Aa.c. (on grid)</td></tr> <tr><td>Rated Output Apparent Power</td><td>30kVA</td></tr> <tr><td>Max. Output Apparent Power</td><td>33.0kVA (off grid) 55.2kVA (on grid)</td></tr> </table>	Nominal Output Voltage	3L/N/PE-220/380, 230/400Va.c.	Nominal Output Frequency	50/60Hz	Rated Output Current	45.5A@380Va.c. 43.5A@400Va.c.	Max. Output Current	50.0Aa.c. (off grid) 80.0Aa.c. (on grid)	Rated Output Apparent Power	30kVA	Max. Output Apparent Power	33.0kVA (off grid) 55.2kVA (on grid)	<p><b>Back-up</b></p> <table border="0"> <tr><td>Nominal Output Voltage</td><td>3L/N/PE-220/380, 230/400Va.c.</td></tr> <tr><td>Nominal Output Frequency</td><td>50/60Hz</td></tr> <tr><td>Rated Output Current</td><td>45.5A@380Va.c. 43.5A@400Va.c.</td></tr> <tr><td>Max. Output Current</td><td>50.0Aa.c. (off grid) 80.0Aa.c. (on grid)</td></tr> <tr><td>Rated Output Apparent Power</td><td>30kVA</td></tr> <tr><td>Max. Output Apparent Power</td><td>33.0kVA (off grid) 55.2kVA (on grid)</td></tr> </table>	Nominal Output Voltage	3L/N/PE-220/380, 230/400Va.c.	Nominal Output Frequency	50/60Hz	Rated Output Current	45.5A@380Va.c. 43.5A@400Va.c.	Max. Output Current	50.0Aa.c. (off grid) 80.0Aa.c. (on grid)	Rated Output Apparent Power	30kVA	Max. Output Apparent Power	33.0kVA (off grid) 55.2kVA (on grid)																								
Nominal Output Voltage	3L/N/PE-220/380, 230/400Va.c.																																																
Nominal Output Frequency	50/60Hz																																																
Rated Output Current	45.5A@380Va.c. 43.5A@400Va.c.																																																
Max. Output Current	50.0Aa.c. (off grid) 80.0Aa.c. (on grid)																																																
Rated Output Apparent Power	30kVA																																																
Max. Output Apparent Power	33.0kVA (off grid) 55.2kVA (on grid)																																																
Nominal Output Voltage	3L/N/PE-220/380, 230/400Va.c.																																																
Nominal Output Frequency	50/60Hz																																																
Rated Output Current	45.5A@380Va.c. 43.5A@400Va.c.																																																
Max. Output Current	50.0Aa.c. (off grid) 80.0Aa.c. (on grid)																																																
Rated Output Apparent Power	30kVA																																																
Max. Output Apparent Power	33.0kVA (off grid) 55.2kVA (on grid)																																																
<p><b>General Data</b></p> <table border="0"> <tr><td>Operating Temperature Range</td><td>-35...+60°C</td></tr> <tr><td>Non-isolated, IP66, Protective Class: I, OVC: DC II/AC III</td><td></td></tr> </table>	Operating Temperature Range	-35...+60°C	Non-isolated, IP66, Protective Class: I, OVC: DC II/AC III		<p><b>General Data</b></p> <table border="0"> <tr><td>Operating Temperature Range</td><td>-35...+60°C</td></tr> <tr><td>Non-isolated, IP66, Protective Class: I, OVC: DC II/AC III</td><td></td></tr> </table>	Operating Temperature Range	-35...+60°C	Non-isolated, IP66, Protective Class: I, OVC: DC II/AC III																																									
Operating Temperature Range	-35...+60°C																																																
Non-isolated, IP66, Protective Class: I, OVC: DC II/AC III																																																	
Operating Temperature Range	-35...+60°C																																																
Non-isolated, IP66, Protective Class: I, OVC: DC II/AC III																																																	
 	 																																																
<p>GoodWe Technologies Co., Ltd. service@goodwe.com No.90 Zjlin Rd., New District, Suzhou, 215011, China</p> 	<p>GoodWe Technologies Co., Ltd. service@goodwe.com No.90 Zjlin Rd., New District, Suzhou, 215011, China</p> 																																																

AFCI label, for models GW5K-ETA-G20, GW6K-ETA-G20, GW8K-ETA-G20:

Sistema de proteção de arcos elétricos em série ("Interrupção de Arco")  
AFCI: F-I-AFPE-1-2/1-2







AFCI label, for models GW9.999K-ETA-G20, GW10K-ETA-G20, GW12K-ETA-G20, GW15K-ETA-G20, GW20K-ETA-G20:







**Sistema de proteção de arcos elétricos em série ("Interrupção de Arco")**  
**AFCI: F-I-AFPE-1-2/2-2**







AFCI label, for models GW25K-ETA-G20, GW29.999K-ETA-G20, GW30K-ETA-G20:







**Sistema de proteção de arcos elétricos em série ("Interrupção de Arco")**  
**AFCI: F-I-AFPE-1-2/4-2**









Labels for the AC-Coupled Inverters:

<b>GOODWE</b>	<b>GOODWE</b>	<b>GOODWE</b>
<b>Product: AC-Coupled Inverter Model: GW5K-BTA-G20</b>	<b>Product: AC-Coupled Inverter Model: GW6K-BTA-G20</b>	<b>Product: AC-Coupled Inverter Model: GW8K-BTA-G20</b>
<b>Battery</b> Battery Voltage Range 700...950Vd.c. Max. Continuous Charging Current 6.7Ad.c. Max. Continuous Discharging Current 7.4Ad.c. Battery Type Li-Ion	<b>Battery</b> Battery Voltage Range 700...950Vd.c. Max. Continuous Charging Current 8.1Ad.c. Max. Continuous Discharging Current 8.9Ad.c. Battery Type Li-Ion	<b>Battery</b> Battery Voltage Range 700...950Vd.c. Max. Continuous Charging Current 10.7Ad.c. Max. Continuous Discharging Current 11.8Ad.c. Battery Type Li-Ion
<b>On-grid</b> Nominal Voltage 3L/N/PE-220/380, 230/400Va.c. Nominal Frequency 50/60Hz Rated Power 5kW Rated Apparent Power to Grid 5kVA Max. Apparent Power to Grid 5kVA Rated Current to Grid 7.6A@380Va.c. 7.3A@400Va.c. Max. Current to Grid 7.6A@380Va.c. 7.3A@400Va.c. Rated Apparent Power from Grid 5kVA Max. Apparent Power from Grid 43.5kVA Rated Current from Grid 7.6A@380Va.c. 7.3A@400Va.c. Max. Current from Grid 63.0Aa.c. Power Factor 0.8lagging...0.8leading	<b>On-grid</b> Nominal Voltage 3L/N/PE-220/380, 230/400Va.c. Nominal Frequency 50/60Hz Rated Power 6kW Rated Apparent Power to Grid 6kVA Max. Apparent Power to Grid 6kVA Rated Current to Grid 9.1A@380Va.c. 8.7A@400Va.c. Max. Current to Grid 9.1A@380Va.c. 8.7A@400Va.c. Rated Apparent Power from Grid 6kVA Max. Apparent Power from Grid 43.5kVA Rated Current from Grid 9.1A@380Va.c. 8.7A@400Va.c. Max. Current from Grid 63.0Aa.c. Power Factor 0.8lagging...0.8leading	<b>On-grid</b> Nominal Voltage 3L/N/PE-220/380, 230/400Va.c. Nominal Frequency 50/60Hz Rated Power 8kW Rated Apparent Power to Grid 8kVA Max. Apparent Power to Grid 8kVA Rated Current to Grid 12.2A@380Va.c. 11.6A@400Va.c. Max. Current to Grid 12.2A@380Va.c. 11.6A@400Va.c. Rated Apparent Power from Grid 8kVA Max. Apparent Power from Grid 43.5kVA Rated Current from Grid 12.2A@380Va.c. 11.6A@400Va.c. Max. Current from Grid 63.0Aa.c. Power Factor 0.8lagging...0.8leading
<b>Back-up</b> Nominal Output Voltage 3L/N/PE-220/380, 230/400Va.c. Nominal Output Frequency 50/60Hz Rated Output Current 7.6A@380Va.c. 7.3A@400Va.c. Max. Output Current 11.4Aa.c. (off grid) 63.0Aa.c. (on grid) Rated Output Apparent Power 5kVA Max. Output Apparent Power 5.5kVA (off grid) 43.5kVA (on grid)	<b>Back-up</b> Nominal Output Voltage 3L/N/PE-220/380, 230/400Va.c. Nominal Output Frequency 50/60Hz Rated Output Current 9.1A@380Va.c. 8.7A@400Va.c. Max. Output Current 13.7Aa.c. (off grid) 63.0Aa.c. (on grid) Rated Output Apparent Power 6kVA Max. Output Apparent Power 6.6kVA (off grid) 43.5kVA (on grid)	<b>Back-up</b> Nominal Output Voltage 3L/N/PE-220/380, 230/400Va.c. Nominal Output Frequency 50/60Hz Rated Output Current 12.2A@380Va.c. 11.6A@400Va.c. Max. Output Current 18.2Aa.c. (off grid) 63.0Aa.c. (on grid) Rated Output Apparent Power 8kVA Max. Output Apparent Power 8.8kVA (off grid) 43.5kVA (on grid)
<b>General Data</b> Operating Temperature Range -35...+60°C Weight 30kg Non-isolated, IP66, Protective Class: I, OVC: DC II/AC III	<b>General Data</b> Operating Temperature Range -35...+60°C Weight 30kg Non-isolated, IP66, Protective Class: I, OVC: DC II/AC III	<b>General Data</b> Operating Temperature Range -35...+60°C Weight 30kg Non-isolated, IP66, Protective Class: I, OVC: DC II/AC III
 	 	 
GoodWe Technologies Co., Ltd. service@goodwe.com No.90 Zijin Rd., New District, Suzhou, 215011, China <span style="float: right; border: 1px solid black; padding: 2px;">QC PASS</span>	GoodWe Technologies Co., Ltd. service@goodwe.com No.90 Zijin Rd., New District, Suzhou, 215011, China <span style="float: right; border: 1px solid black; padding: 2px;">QC PASS</span>	GoodWe Technologies Co., Ltd. service@goodwe.com No.90 Zijin Rd., New District, Suzhou, 215011, China <span style="float: right; border: 1px solid black; padding: 2px;">QC PASS</span>

<p><b>GOODWE</b>  <b>Product: AC-Coupled Inverter</b>  <b>Model: GW9.999K-BTA-G20</b></p> <p><b>Battery</b>                  Battery Voltage Range 700...950Vd.c.                  Max. Continuous Charging Current 13.4Ad.c.                  Max. Continuous Discharging Current 14.7Ad.c.                  Battery Type Li-Ion</p> <p><b>On-grid</b>                  Nominal Voltage 3L/N/PE-220/380, 230/400Va.c.                  Nominal Frequency 50/60Hz                  Rated Power 9.999kW                  Rated Apparent Power to Grid 9.999kVA                  Max. Apparent Power to Grid 9.999kVA                  Rated Current to Grid 15.2A@380Va.c.                  14.5A@400Va.c.                  Max. Current to Grid 15.2A@380Va.c.                  14.5A@400Va.c.                  Rated Apparent Power from Grid 9.999kVA                  Max. Apparent Power from Grid 43.5kVA                  Rated Current from Grid 15.2A@380Va.c.                  14.5A@400Va.c.                  Max. Current from Grid 63.0Aa.c.                  Power Factor 0.8lagging...0.8leading</p> <p><b>Back-up</b>                  Nominal Output Voltage 3L/N/PE-220/380, 230/400Va.c.                  Nominal Output Frequency 50/60Hz                  Rated Output Current 15.2A@380Va.c.                  14.5A@400Va.c.                  Max. Output Current 22.8Aa.c. (off grid)                  63.0Aa.c. (on grid)                  Rated Output Apparent Power 10kVA                  Max. Output Apparent Power 11.0kVA (off grid)                  43.5kVA (on grid)</p> <p><b>General Data</b>                  Operating Temperature Range -35...+60°C                  Weight 30kg                  Non-isolated, IP66, Protective Class: I, OVC: DC II/AC III</p> <p> </p> <p>GoodWe Technologies Co., Ltd.                  service@goodwe.com                  No.90 Zijin Rd., New District, Suzhou, 215011, China <b>QC PASS</b></p>	<p><b>GOODWE</b>  <b>Product: AC-Coupled Inverter</b>  <b>Model: GW10K-BTA-G20</b></p> <p><b>Battery</b>                  Battery Voltage Range 700...950Vd.c.                  Max. Continuous Charging Current 13.4Ad.c.                  Max. Continuous Discharging Current 14.7Ad.c.                  Battery Type Li-Ion</p> <p><b>On-grid</b>                  Nominal Voltage 3L/N/PE-220/380, 230/400Va.c.                  Nominal Frequency 50/60Hz                  Rated Power 10kW                  Rated Apparent Power to Grid 10kVA                  Max. Apparent Power to Grid 10kVA                  Rated Current to Grid 15.2A@380Va.c.                  14.5A@400Va.c.                  Max. Current to Grid 15.2A@380Va.c.                  14.5A@400Va.c.                  Rated Apparent Power from Grid 10kVA                  Max. Apparent Power from Grid 43.5kVA                  Rated Current from Grid 15.2A@380Va.c.                  14.5A@400Va.c.                  Max. Current from Grid 63.0Aa.c.                  Power Factor 0.8lagging...0.8leading</p> <p><b>Back-up</b>                  Nominal Output Voltage 3L/N/PE-220/380, 230/400Va.c.                  Nominal Output Frequency 50/60Hz                  Rated Output Current 15.2A@380Va.c.                  14.5A@400Va.c.                  Max. Output Current 22.8Aa.c. (off grid)                  63.0Aa.c. (on grid)                  Rated Output Apparent Power 10kVA                  Max. Output Apparent Power 11.0kVA (off grid)                  43.5kVA (on grid)</p> <p><b>General Data</b>                  Operating Temperature Range -35...+60°C                  Weight 30kg                  Non-isolated, IP66, Protective Class: I, OVC: DC II/AC III</p> <p> </p> <p>GoodWe Technologies Co., Ltd.                  service@goodwe.com                  No.90 Zijin Rd., New District, Suzhou, 215011, China <b>QC PASS</b></p>	<p><b>GOODWE</b>  <b>Product: AC-Coupled Inverter</b>  <b>Model: GW12K-BTA-G20</b></p> <p><b>Battery</b>                  Battery Voltage Range 700...950Vd.c.                  Max. Continuous Charging Current 16.1Ad.c.                  Max. Continuous Discharging Current 17.7Ad.c.                  Battery Type Li-Ion</p> <p><b>On-grid</b>                  Nominal Voltage 3L/N/PE-220/380, 230/400Va.c.                  Nominal Frequency 50/60Hz                  Rated Power 12kW                  Rated Apparent Power to Grid 12kVA                  Max. Apparent Power to Grid 12kVA                  Rated Current to Grid 18.2A@380Va.c.                  17.4A@400Va.c.                  Max. Current to Grid 18.2A@380Va.c.                  17.4A@400Va.c.                  Rated Apparent Power from Grid 12kVA                  Max. Apparent Power from Grid 43.5kVA                  Rated Current from Grid 18.2A@380Va.c.                  17.4A@400Va.c.                  Max. Current from Grid 63.0Aa.c.                  Power Factor 0.8lagging...0.8leading</p> <p><b>Back-up</b>                  Nominal Output Voltage 3L/N/PE-220/380, 230/400Va.c.                  Nominal Output Frequency 50/60Hz                  Rated Output Current 18.2A@380Va.c.                  17.4A@400Va.c.                  Max. Output Current 27.3Aa.c. (off grid)                  63.0Aa.c. (on grid)                  Rated Output Apparent Power 12kVA                  Max. Output Apparent Power 13.2kVA (off grid)                  43.5kVA (on grid)</p> <p><b>General Data</b>                  Operating Temperature Range -35...+60°C                  Weight 30kg                  Non-isolated, IP66, Protective Class: I, OVC: DC II/AC III</p> <p> </p> <p>GoodWe Technologies Co., Ltd.                  service@goodwe.com                  No.90 Zijin Rd., New District, Suzhou, 215011, China <b>QC PASS</b></p>
---	--	--

<p><b>GOODWE</b>  <b>Product: AC-Coupled Inverter</b>  <b>Model: GW15K-BTA-G20</b></p> <p><b>Battery</b>                  Battery Voltage Range 700...950Vd.c.                  Max. Continuous Charging Current 20.1Ad.c.                  Max. Continuous Discharging Current 22.1Ad.c.                  Battery Type Li-Ion</p> <p><b>On-grid</b>                  Nominal Voltage 3L/N/PE-220/380, 230/400Va.c.                  Nominal Frequency 50/60Hz                  Rated Power 15kW                  Rated Apparent Power to Grid 15kVA                  Max. Apparent Power to Grid 15kVA                  Rated Current to Grid 22.8A@380Va.c.                  Max. Current to Grid 22.8A@380Va.c.                  Rated Apparent Power from Grid 15kVA                  Max. Apparent Power from Grid 43.5kVA                  Rated Current from Grid 22.8A@380Va.c.                  Max. Current from Grid 63.0Aa.c.                  Power Factor 0.8lagging...0.8leading</p> <p><b>Back-up</b>                  Nominal Output Voltage 3L/N/PE-220/380, 230/400Va.c.                  Nominal Output Frequency 50/60Hz                  Rated Output Current 22.8A@380Va.c.                  Max. Output Current 33.4Aa.c. (off grid)                  Rated Output Apparent Power 15kVA                  Max. Output Apparent Power 16.5kVA (off grid)</p> <p><b>General Data</b>                  Operating Temperature Range -35...+60°C                  Weight 30kg                  Non-isolated, IP66, Protective Class: I, OVC: DC II/AC III</p> <p> </p> <p>GoodWe Technologies Co., Ltd.                  service@goodwe.com                  No.90 Zijin Rd., New District, Suzhou, 215011, China</p> <p><b>QC PASS</b></p>	<p><b>GOODWE</b>  <b>Product: AC-Coupled Inverter</b>  <b>Model: GW20K-BTA-G20</b></p> <p><b>Battery</b>                  Battery Voltage Range 700...950Vd.c.                  Max. Continuous Charging Current 26.7Ad.c.                  Max. Continuous Discharging Current 29.4Ad.c.                  Battery Type Li-Ion</p> <p><b>On-grid</b>                  Nominal Voltage 3L/N/PE-220/380, 230/400Va.c.                  Nominal Frequency 50/60Hz                  Rated Power 20kW                  Rated Apparent Power to Grid 20kVA                  Max. Apparent Power to Grid 20kVA                  Rated Current to Grid 30.4A@380Va.c.                  Max. Current to Grid 30.4A@380Va.c.                  Rated Apparent Power from Grid 20kVA                  Max. Apparent Power from Grid 43.5kVA                  Rated Current from Grid 30.4A@380Va.c.                  Max. Current from Grid 63.0Aa.c.                  Power Factor 0.8lagging...0.8leading</p> <p><b>Back-up</b>                  Nominal Output Voltage 3L/N/PE-220/380, 230/400Va.c.                  Nominal Output Frequency 50/60Hz                  Rated Output Current 30.4A@380Va.c.                  Max. Output Current 33.4Aa.c. (off grid)                  Rated Output Apparent Power 20kVA                  Max. Output Apparent Power 22.0kVA (off grid)</p> <p><b>General Data</b>                  Operating Temperature Range -35...+60°C                  Weight 30kg                  Non-isolated, IP66, Protective Class: I, OVC: DC II/AC III</p> <p> </p> <p>GoodWe Technologies Co., Ltd.                  service@goodwe.com                  No.90 Zijin Rd., New District, Suzhou, 215011, China</p> <p><b>QC PASS</b></p>	<p><b>GOODWE</b>  <b>Product: AC-Coupled Inverter</b>  <b>Model: GW25K-BTA-G20</b></p> <p><b>Battery</b>                  Battery Voltage Range 700...950Vd.c.                  Max. Continuous Charging Current 33.3Ad.c.                  Max. Continuous Discharging Current 36.7Ad.c.                  Battery Type Li-Ion</p> <p><b>On-grid</b>                  Nominal Voltage 3L/N/PE-220/380, 230/400Va.c.                  Nominal Frequency 50/60Hz                  Rated Power 25kW                  Rated Apparent Power to Grid 25kVA                  Max. Apparent Power to Grid 25kVA                  Rated Current to Grid 37.9A@380Va.c.                  Max. Current to Grid 37.9A@380Va.c.                  Rated Apparent Power from Grid 25kVA                  Max. Apparent Power from Grid 55.2kVA                  Rated Current from Grid 37.9A@380Va.c.                  Max. Current from Grid 80.0Aa.c.                  Power Factor 0.8lagging...0.8leading</p> <p><b>Back-up</b>                  Nominal Output Voltage 3L/N/PE-220/380, 230/400Va.c.                  Nominal Output Frequency 50/60Hz                  Rated Output Current 37.9A@380Va.c.                  Max. Output Current 50Aa.c. (off grid)                  Rated Output Apparent Power 25kVA                  Max. Output Apparent Power 27.5kVA (off grid)</p> <p><b>General Data</b>                  Operating Temperature Range -35...+60°C                  Weight 32kg                  Non-isolated, IP66, Protective Class: I, OVC: DC II/AC III</p> <p> </p> <p>GoodWe Technologies Co., Ltd.                  service@goodwe.com                  No.90 Zijin Rd., New District, Suzhou, 215011, China</p> <p><b>QC PASS</b></p>
---	---	---

<b>GOODWE</b>	<b>GOODWE</b>
<b>Product: AC-Coupled Inverter</b> <b>Model: GW29.999K-BTA-G20</b>	<b>Product: AC-Coupled Inverter</b> <b>Model: GW30K-BTA-G20</b>
<b>Battery</b>	<b>Battery</b>
Battery Voltage Range	700...950Vd.c.
Max. Continuous Charging Current	40.0Ad.c.
Max. Continuous Discharging Current	44.1Ad.c.
Battery Type	Li-Ion
<b>On-grid</b>	<b>On-grid</b>
Nominal Voltage	3L/N/PE-220/380, 230/400Va.c.
Nominal Frequency	50/60Hz
Rated Power	29.999kW
Rated Apparent Power to Grid	29.999kVA
Max. Apparent Power to Grid	29.999kVA
Rated Current to Grid	45.5A@380Va.c. 43.5A@400Va.c.
Max. Current to Grid	45.5A@380Va.c. 43.5A@400Va.c.
Rated Apparent Power from Grid	29.999kVA
Max. Apparent Power from Grid	55.2kVA
Rated Current from Grid	45.5A@380Va.c. 43.5A@400Va.c.
Max. Current from Grid	80.0Aa.c.
Power Factor	0.8lagging...0.8leading
<b>Back-up</b>	<b>Back-up</b>
Nominal Output Voltage	3L/N/PE-220/380, 230/400Va.c.
Nominal Output Frequency	50/60Hz
Rated Output Current	45.5A@380Va.c. 43.5A@400Va.c.
Max. Output Current	50.0Aa.c. (off grid) 80.0Aa.c. (on grid)
Rated Output Apparent Power	30kVA
Max. Output Apparent Power	33.0kVA (off grid) 55.2kVA (on grid)
<b>General Data</b>	<b>General Data</b>
Operating Temperature Range	-35...+60°C
Weight	32kg
Non-isolated, IP66, Protective Class: I, OVC: DC II/AC III	
 	 
GoodWe Technologies Co., Ltd. service@goodwe.com No.90 Zijin Rd., New District, Suzhou, 215011, China	GoodWe Technologies Co., Ltd. service@goodwe.com No.90 Zijin Rd., New District, Suzhou, 215011, China
	

<b>⚠ DANGER/PERIGO</b>	
	EN: High voltage hazard, avoid electric shock. PT: Perigo de alta tensão, evite choques elétricos.
	EN: Potential hazard, operate carefully. PT: Perigo potencial, operar com cuidado.
	EN: Do not disconnect under operation! PT: Não desconecte durante a operação!
<b>⚠ CAUTION/ATENÇÃO</b>	
	EN: Read related manuals. PT: verificar no manual do equipamento a forma adequada de realizar a instalação elétrica e se há necessidade de de dispositivos de proteções elétrica adicionais.
	EN: Wear protective goggles. PT: Use óculos de proteção.
	EN: Dispose of the equipment properly. PT: Descarte o equipamento de forma adequada.
<b>⚠ DANGER/PERIGO</b>	
	EN: Hot surface, do not touch to avoid burns. PT: Superfície quente, não toque para evitar queimaduras.
	EN: Electric shock hazard. Disconnect the AC switch and then the DC switch to power off the equipment. Wait 5 minutes after disconnecting.
	PT: Perigo de choque elétrico. Desconecte o interruptor AC e, em seguida, o interruptor DC para desligar o equipamento. Aguarde 5 minutos após a desconexão.

Importer information:

Importer: GoodWe Europe GmbH Address: Kistlerhof Str. 170, 81379 Munich, Germany	(Europe)
Importer: GoodWe Power Supply Technology Co., Ltd Address: First Floor, Sutherland House, 5-6 Argyll Street, London, England, W1F 7TE	(UK)
Importer: Goodwe Australia Pty.Ltd Address: 19Fairleigh Street, Glenroy, VIC 3046, AUSTRALIA	(Australia&New Zealand)
Detentor do Registro INMETRO: PRODUCT HOLDER CERTIFICATION SOLUTIONIS LTDA CNPJ: 28.707.531/0001-38 Address: Estrada Geral S/N, Ibiraquera, CEP 88780-000, Imbituba - SC Brazil	(Brazil)

<b>POSSIBLE TEST CASE VERDICTS:</b>	
- test case does not apply to the test object.....:	N/A
- test object does meet the requirement .....	P (Pass)
- test object does not meet the requirement .....	F (Fail)
<b>TESTING:</b>	
Date of receipt of test item .....	See cover page
Date (s) of performance of tests .....	See cover page
<b>GENERAL REMARKS:</b>	
<p><b>"(See Enclosure #)" refers to additional information appended to the report.</b>  <b>"(See appended table)" refers to a table appended to the report.</b></p> <p><b>This Test Report is only applicable to controls using software. This TRF is to be used in conjunction with the IEC 60730-1.</b></p> <p><b>Throughout this report a <input type="checkbox"/> comma / <input checked="" type="checkbox"/> point is used as the decimal separator.</b></p> <p><b>When differences exist; they shall be identified in the General product information section.</b></p>	
<b>Name and address of factory (ies) .....</b>	<p><b>Address 1:</b> GoodWe (GuangDe) Power Supply Technology Co., Ltd.                      No.208, Tong Rui East Road, Guangde, Anhui, P.R. China</p> <p><b>Address 2:</b> GOODWE VIETNAM TECHNOLOGY COMPANY LIMITED                      Factory A1, A2, Lot CN1N, maritime Industrial and Service Park (Deep C2B), Dinh Vu -Cat Hai Economic Zone, Dong Hai 2 Ward, Hai An District, Hai Phong City, Vietnam</p>
<b>GENERAL PRODUCT INFORMATION:</b>	
<u>Product Description:</u>	
<p>The equipment under test (EUTs) are three-phase Grid-connected hybrid inverters, which designed to work with PV panels up to 1000Vd.c and batteries up to 950Vd.c. It is responsible for converting the direct current generated by photovoltaic panels and batteries into three-phase 220/380Vac, 230/400Vac, 50/60Hz alternative current for feeding into the electrical power distribution grid. And the battery port can be charged by the energy from either PV port or AC grid port. The EUTs can work in stand-alone mode while the grid voltage is not present.</p> <p>There are built-in relays inside of the inverter's ON-GRID and BACK-UP AC ports. There are two sets of Grid Relay, the Back-up circuit is located between two relays, the Grid relay was evaluated with functional safety acc. to IEC 60730-1 Annex H.</p> <p>When the inverter is in the off-grid mode, the built-in ON-GRID relay is open; while when the inverter is in grid-tied mode, it is closed. Power off the inverter first if maintenance is required for the loads connected with BACK-UP ports. Otherwise, it may cause electric shock.</p> <p>The hybrid inverters support AFPE (Arc Fault Protection Equipment) for arc detection and interruption, which is combination of AFD and AFI to detect and interrupt arc faults. The AFPEs are implemented within the inverters connected to the PV array and make use of the housing and terminals of the inverters.</p> <p>Due to AFPE circuits employ a programmable circuit component to achieve the arc flash detection and interruption, functional safety evaluation was performed according to IEC 60730-1, Annex H.</p> <p>Compared with the hybrid inverter, the AC-Coupled Inverters has removed the PV connection circuit, while the other hardware is the same.</p>	

See the block diagram for details.

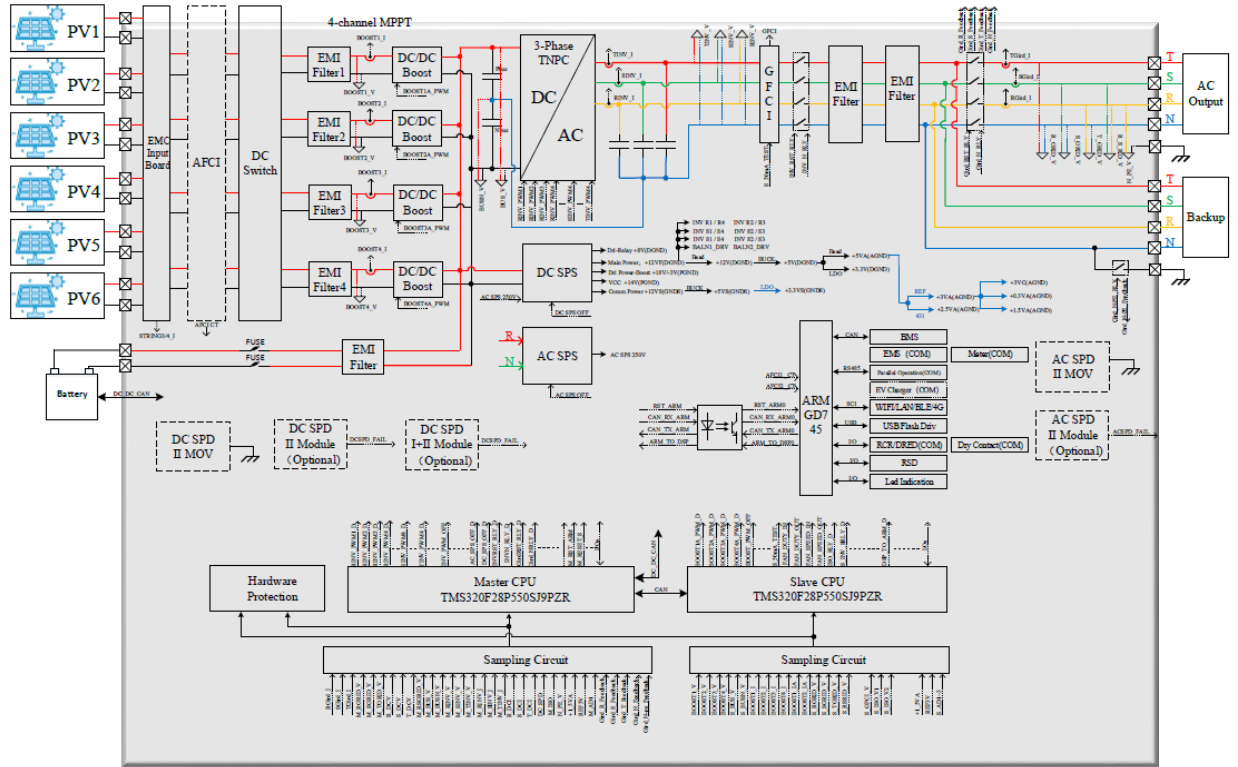

Block diagram for hybrid inverter

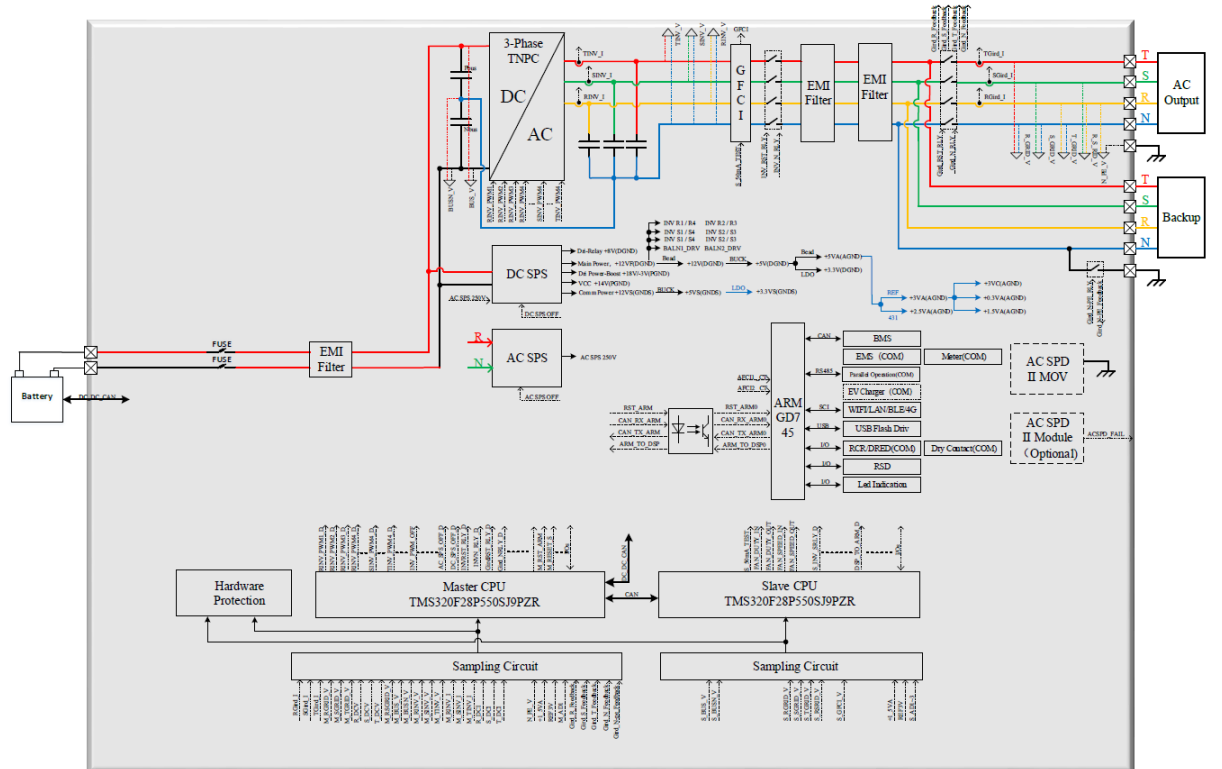

Block diagram for AC-Coupled Inverters

Safety Function(s) Investigated:

Safety Function	Compliance Criteria
Grid relay adhesion fault detection	Class B Control Function
NPE relay adhesion fault detection	Class B Control Function
Arc protection function	Class B Control Function

Model Difference

For hybrid inverter, all models are identical in hardware as well as software, except for the type of designation, electrical ratings, numbers of external fans, AC relays, etc. see the next table for details.

And the model GW29.999K-ETA-G20 is identical to model GW30K-ETA-G20 except for model names and power rating, and they have the same PCB layout and circuit including the components, and based on the test requirements, tested on model GW30K-ETA-G20 can represent the model GW29.999K-ETA-G20.

Model Difference	GW5K-ETA-G20, GW6K-ETA-G20, GW8K-ETA-G20	GW9.999K-ETA-G20, GW10K-ETA-G20, GW12K-ETA-G20	GW15K-ETA-G20, GW20K-ETA-G20	GW25K-ETA-G20, GW29.999K-ETA-G20, GW30K-ETA-G20
Number of MPP Trackers	3	4	4	4
Max. MPPT current [A <sub>dc</sub> ]	21/21/21	21/21/21/21	21/21/21/21	21/21/42/42
BUS film capacitor	50uF*4	50uF*4	50uF*4	50uF*6
Number of electrolytic capacitors	680uF*4	680uF*4	680uF*6	680uF*8
AC hall	20A	32A	50A	50A
INV side filter capacitor	4.7uF	4.7uF	8uF	12uF
Grid side filter capacitor	4.7uF	4.7uF	4.7uF	4.7uF
INV side relay	31A	31A	50A	50A
Grid side relay	100A	100A	100A	100A
INV power choke	770uH@17.1A	550uH@26A	290uH@43A	200uH@65A
Battery port fuse	63A	63A	100A	100A
Number of external fans	1	1	1	3

For AC-Coupled Inverters, all models are identical in hardware as well as software, except for the type of designation, electrical ratings, AC relays, etc. see the next table for details.

Difference	Model	GW5K-BTA-G20, GW6K-BTA-G20, GW8K-BTA-G20	GW9.999K-BTA-G20, GW10K-BTA-G20, GW12K-BTA-G20	GW15K-BTA-G20, GW20K-BTA-G20	GW25K-BTA-G20, GW29.999K-BTA-G20, GW30K-BTA-G20
BUS film capacitor		50uF*4	50uF*4	50uF*4	50uF*6
Number of electrolytic capacitors		680uF*4	680uF*4	680uF*6	680uF*8
AC hall		20A	32A	50A	50A
INV side filter capacitor		4.7uF	4.7uF	8uF	12uF
Grid side filter capacitor		4.7uF	4.7uF	4.7uF	4.7uF
INV side relay		31A	31A	50A	50A
Grid side relay		100A	100A	100A	100A
INV power choke		770uH@17.1A	550uH@26A	290uH@43A	200uH@65A
Battery port fuse		63A	63A	100A	100A
Number of external fans		1	1	1	3

Unless otherwise specified, all the tests performed on the basic model of GW30K-ETA-G20 to represent the others.

Model list:

MODELS LIST		GW5K-ETA-G20	GW6K-ETA-G20	GW8K-ETA-G20	GW9.999K-ETA-G20	GW10K-ETA-G20	GW12K-ETA-G20
PV INPUT	V <sub>MAX</sub> PV [Vdc]	1000					
	MPP Voltage Range V <sub>MPP</sub> [Vdc]	120-950					
	MPP Voltage Range for Full power [Vdc]	185-850	225-850	300-850	250-850	250-850	300-850
	Nominal PV Voltage V <sub>nom</sub> [Vdc]	750					
	Start PV Voltage [Vdc]	150					
	I <sub>sc</sub> PV [A]	26/26/26	26/26/26	26/26/26	26/26/26/26	26/26/26/26	26/26/26/26
	Max. Input Current I <sub>max</sub> [Adc]	21/21/21	21/21/21	21/21/21	21/21/21/21	21/21/21/21	21/21/21/21
	Backfeed Current [Adc]	0					
	Oversvoltage Category (OVC)	OVC II					
Battery INPUT	Battery Type	Li-Ion					
	V <sub>MAX</sub> BAT [Vdc]	950					
	Voltage Range [Vdc]	700-950					
	Start Voltage [Vdc]	720					
	Max. Charge Current [Adc]	6.7	8.1	10.7	13.4	13.4	16.1
	Max. Discharge Current [Adc]	7.4	8.9	11.8	14.7	14.7	17.7
	Oversvoltage Category (OVC)	OVC II					
AC OUTPUT	Rated Output Voltage U <sub>r</sub> [Vac]	220/380, 230/400, 3L/N/PE					
	Rated Output Frequency F <sub>NETZ</sub> [Hz]	50/60					

	Rated Operating Frequency Range $F_n$ [Hz]	45-55 / 55-65					
	Rated Output Power $P_E$ [kW]	5	6	8	9.999	10	12
	Rated Apparent Power to Grid [kVA]	5	6	8	9.999	10	12
	Rated Apparent Power from Grid [kVA]	5	6	8	9.999	10	12
	Max. Apparent Power to Grid [kVA]	5	6	8	9.999	10	12
	Max. Apparent Power from Grid [kVA]	43.5	43.5	43.5	43.5	43.5	43.5
	Rated Current to Grid [Aac]	7.6@380V 7.3@400V	9.1@380V 8.7@400V	12.2@380V 11.6@400V	15.2@380V 14.5@400V	15.2@380V 14.5@400V	18.2@380V 17.4@400V
	Rated Current from Grid [Aac]	7.6@380V 7.3@400V	9.1@380V 8.7@400V	12.2@380V 11.6@400V	15.2@380V 14.5@400V	15.2@380V 14.5@400V	18.2@380V 17.4@400V
	Max. Current to Grid [Aac]	7.6@380V 7.3@400V	9.1@380V 8.7@400V	12.2@380V 11.6@400V	15.2@380V 14.5@400V	15.2@380V 14.5@400V	18.2@380V 17.4@400V
	Max. Current from Grid [Aac]	63.0	63.0	63.0	63.0	63.0	63.0
	Power Factor $\cos\phi$ [ $\lambda$ ]	[-0.80 0.80]					
	Overvoltage Category (OVC)	OVC III					
Back up	Rated Output Voltage $U_r$ [Vac]	220/380, 230/400, 3L/N/PE					
	Rated Output Frequency $F_{NETZ}$ [Hz]	50/60					
	Normal Operating Frequency Range $F_n$ [Hz]	45-55 / 55-65					
	Rated Output Apparent Power [kVA]	5	6	8	10	10	12
	Max. Output Apparent Power* [kVA]	off-grid: 5.5 on-grid: 43.5	off-grid: 6.6 on-grid: 43.5	off-grid: 8.8 on-grid: 43.5	off-grid: 11.0 on-grid: 43.5	off-grid: 11.0 on-grid: 43.5	off-grid: 13.2 on-grid: 43.5
	Rated Output Current [Aac]	7.6@380V 7.3@400V	9.1@380V 8.7@400V	12.2@380V 11.6@400V	15.2@380V 14.5@400V	15.2@380V 14.5@400V	18.2@380V 17.4@400V

	Max. Output Current* [Aac]	off-grid: 11.4 on-grid: 63.0	off-grid: 13.7 on-grid: 63.0	off-grid: 18.2 on-grid: 63.0	off-grid: 22.8 on-grid: 63.0	off-grid: 22.8 on-grid: 63.0	off-grid: 27.3 on-grid: 63.0
SYSTEM	Protective Class	I					
	Enclosure Protection (IP)	IP66					
	Operating Temperature Range [°C]	-35 to +60 (>40 derating)					
	Pollution degree (PD)	External PD3/Internal PD 2					
	Max. Operating Altitude [m]	Max. 4000					
	Weight [kg]	34	34	34	34	34	34
	Size [mm] (W*H*D mm)	800*340*270					
	Type of inverter	Non-isolated					
	Firmware version	010101					
Note: *: "off-grid" means the energy of backup output only comes from PV and battery. "on-grid" means the energy of the backup output includes the energy from grid or generator (on-grid port, connected via an ATS switch) side.							
MODELS LIST		GW15K-ETA-G20	GW20K-ETA-G20	GW25K-ETA-G20	GW29.999K-ETA-G20	GW30K-ETA-G20	
PV INPUT	V <sub>MAX</sub> PV [Vdc]	1000					
	MPP Voltage Range V <sub>MPP</sub> [Vdc]	120-950					
	MPP Voltage Range for Full power [Vdc]	360-850	400-850	400-850	450-850	450-850	
	Nominal PV Voltage V <sub>nom</sub> [Vdc]	750					
	Start PV Voltage [Vdc]	150					
	I <sub>SC</sub> PV [Aac]	26/26/26/26	26/26/26/26	26/26/52/52	26/26/52/52	26/26/52/52	
	Max. Input Current I <sub>max</sub> [Aac]	21/21/21/21	21/21/21/21	21/21/42/42	21/21/42/42	21/21/42/42	
	Backfeed Current [Aac]	0					
	Overvoltage Category (OVC)	OVC II					
Battery INPUT	Battery Type	Li-Ion					
	V <sub>MAX</sub> BAT [Vdc]	950					
	Voltage Range [Vdc]	700-950					

	Start Voltage [Vdc]	720				
	Max. Charge Current [A]	20.1	26.7	33.3	40.0	40.0
	Max. Discharge Current [Adc]	22.1	29.4	36.7	44.1	44.1
	Overvoltage Category (OVC)	OVC II				
AC OUTPUT	Rated Output Voltage $U_r$ [Vac]	220/380, 230/400, 3L/N/PE				
	Rated Output Frequency $F_{NETZ}$ [Hz]	50/60				
	Rated Operating Frequency Range $F_n$ [Hz]	45-55 / 55-65				
	Rated Output Power $P_E$ [kW]	15	20	25	29.999	30
	Rated Apparent Power to Grid [kVA]	15	20	25	29.999	30
	Rated Apparent Power from Grid [kVA]	15	20	25	29.999	30
	Max. Apparent Power to Grid [kVA]	15	20	25	29.999	30
	Max. Apparent Power from Grid [kVA]	43.5	43.5	55.2	55.2	55.2
	Rated Current to Grid [Aac]	22.8@380V 21.8@400V	30.4@380V 29.0@400V	37.9@380V 36.3@400V	45.5@380V 43.5@400V	45.5@380V 43.5@400V
	Rated Current from Grid [Aac]	22.8@380V 21.8@400V	30.4@380V 29.0@400V	37.9@380V 36.3@400V	45.5@380V 43.5@400V	45.5@380V 43.5@400V
	Max. Current to Grid [Aac]	22.8@380V 21.8@400V	30.4@380V 29.0@400V	37.9@380V 36.3@400V	45.5@380V 43.5@400V	45.5@380V 43.5@400V
	Max. Current from Grid [Aac]	63.0	63.0	80.0	80.0	80.0
		Power Factor $\cos\phi$ [ $\lambda$ ]	[-0.80 0.80]			
	Overvoltage Category (OVC)	OVC III				
Back up	Rated Output Voltage $U_r$ [Vac]	220/380, 230/400, 3L/N/PE				
	Rated Output Frequency $F_{NETZ}$ [Hz]	50/60				
	Normal Operating Frequency Range $F_n$ [Hz]	45-55 / 55-65				
	Rated Output Apparent Power [kVA]	15	20	25	30	30

	Max. Output Apparent Power* [kVA]	off-grid: 16.5 on-grid: 43.5	off-grid: 22.0 on-grid: 43.5	off-grid: 27.5 on-grid: 55.2	off-grid: 33.0 on-grid: 55.2	off-grid: 33.0 on-grid: 55.2	
	Rated Output Current [Aac]	22.8@380V 21.8@400V	30.4@380V 29.0@400V	37.9@380V 36.3@400V	45.5@380V 43.5@400V	45.5@380V 43.5@400V	
	Max. Output Current* [Aac]	off-grid: 33.4 on-grid: 63.0	off-grid: 33.4 on-grid: 63.0	off-grid: 50.0 on-grid: 80.0	off-grid: 50.0 on-grid: 80.0	off-grid: 50.0 on-grid: 80.0	
SYSTEM	Protective Class	I					
	Enclosure Protection (IP)	IP66					
	Operating Temperature Range [°C]	-35 to +60 (>40 derating)					
	Pollution degree (PD)	External PD3/Internal PD 2					
	Max. Operating Altitude [m]	Max. 4000					
	Weight [kg]	34	34	38	38	38	
	Size [mm] (W*H*D mm)	800*340*270					
	Type of inverter	Non-isolated					
	Firmware version	010101					
Note: *: "off-grid" means the energy of backup output only comes from PV and battery. "on-grid" means the energy of the backup output includes the energy from grid or generator (on-grid port, connected via an ATS switch) side.							
MODELS LIST		GW5K-BTA-G20	GW6K-BTA-G20	GW8K-BTA-G20	GW9.999K-BTA-G20	GW10K-BTA-G20	GW12K-BTA-G20
Battery INPUT	Battery Type	Li-Ion					
	V <sub>MAX</sub> BAT [Vdc]	950					
	Voltage Range [Vdc]	700-950					
	Start Voltage [Vdc]	720					
	Max. Charge Current [Adc]	6.7	8.1	10.7	13.4	13.4	16.1
	Max. Discharge Current [Adc]	7.4	8.9	11.8	14.7	14.7	17.7
	Overvoltage Category (OVC)	OVC II					
AC OUTPUT	Rated Output Voltage Ur [Vac]	220/380, 230/400, 3L/N/PE					
	Rated Output Frequency F <sub>NETZ</sub> [Hz]	50/60					
	Rated Operating Frequency Range F <sub>n</sub> [Hz]	45-55 / 55-65					
	Rated Output Power P <sub>E</sub> [kW]	5	6	8	9.999	10	12

	Rated Apparent Power to Grid [kVA]	5	6	8	9.999	10	12
	Rated Apparent Power from Grid [kVA]	5	6	8	9.999	10	12
	Max. Apparent Power to Grid [kVA]	5	6	8	9.999	10	12
	Max. Apparent Power from Grid [kVA]	43.5	43.5	43.5	43.5	43.5	43.5
	Rated Current to Grid [Aac]	7.6@380V 7.3@400V	9.1@380V 8.7@400V	12.2@380V 11.6@400V	15.2@380V 14.5@400V	15.2@380V 14.5@400V	18.2@380V 17.4@400V
	Rated Current from Grid [Aac]	7.6@380V 7.3@400V	9.1@380V 8.7@400V	12.2@380V 11.6@400V	15.2@380V 14.5@400V	15.2@380V 14.5@400V	18.2@380V 17.4@400V
	Max. Current to Grid [Aac]	7.6@380V 7.3@400V	9.1@380V 8.7@400V	12.2@380V 11.6@400V	15.2@380V 14.5@400V	15.2@380V 14.5@400V	18.2@380V 17.4@400V
	Max. Current from Grid [Aac]	63.0	63.0	63.0	63.0	63.0	63.0
	Power Factor cosφ [λ]	[-0.80. 0.80]					
	Overtoltage Category (OVC)	OVC III					
Back up	Rated Output Voltage Ur [Vac]	220/380, 230/400, 3L/N/PE					
	Rated Output Frequency F <sub>NETZ</sub> [Hz]	50/60					
	Normal Operating Frequency Range F <sub>n</sub> [Hz]	45-55 / 55-65					
	Rated Output Apparent Power [kVA]	5	6	8	10	10	12
	Max. Output Apparent Power* [kVA]	off-grid: 5.5 on-grid: 43.5	off-grid: 6.6 on-grid: 43.5	off-grid: 8.8 on-grid: 43.5	off-grid: 11 on-grid: 43.5	off-grid: 11 on-grid: 43.5	off-grid: 13.2 on-grid: 43.5
SYSTEM	Rated Output Current [Aac]	7.6@380V 7.3@400V	9.1@380V 8.7@400V	12.2@380V 11.6@ 400V	15.2@380V 14.5@400V	15.2@380V 14.5@400V	18.2@380V 17.4@400V
	Max. Output Current* [Aac]	off-grid: 11.4 on-grid: 63	off-grid: 13.7 on-grid: 63	off-grid: 18.2 on-grid: 63	off-grid: 22.8 on-grid: 63	off-grid: 22.8 on-grid: 63	off-grid: 27.3 on-grid: 63
	Protective Class	I					
	Enclosure Protection (IP)	IP66					
SYSTEM	Operating Temperature Range [°C]	-35 to +60 (>40 derating)					
	Pollution degree (PD)	External PD3/Internal PD 2					
	Max. Operating Altitude [m]	Max. 4000					

	Weight [kg]	30	30	30	30	30	30
	Size [mm] (W*H*D mm)	800*340*270					
	Type of inverter	Non-isolated					
	Firmware version	010101					
Note: *: "off-grid" means the energy of backup output only comes from battery. "on-grid" means the energy of the backup output includes the energy from grid or generator (on-grid port, connected via an ATS switch) side.							
MODELS LIST		GW15K-BTA-G20	GW20K-BTA-G20	GW25K-BTA-G20	GW29.999K-BTA-G20	GW30K-BTA-G20	
Battery INPUT	Battery Type	Li-Ion					
	V <sub>MAX</sub> BAT [Vdc]	950					
	Voltage Range [Vdc]	700-950					
	Start Voltage [Vdc]	720					
	Max. Charge Current [Adc]	20.1	26.7	33.3	40.0	40.0	
	Max. Discharge Current [Adc]	22.1	29.4	36.7	44.1	44.1	
	Overvoltage Category (OVC)	OVC II					
AC OUTPUT	Rated Output Voltage Ur [Vac]	220/380, 230/400, 3L/N/PE					
	Rated Output Frequency F <sub>NETZ</sub> [Hz]	50/60					
	Rated Operating Frequency Range F <sub>n</sub> [Hz]	45-55 / 55-65					
	Rated Output Power P <sub>E</sub> [kW]	15	20	25	29.999	30	
	Rated Apparent Power to Grid [kVA]	15	20	25	29.999	30	
	Rated Apparent Power from Grid [kVA]	15	20	25	29.999	30	
	Max. Apparent Power to Grid [kVA]	15	20	25	29.999	30	
	Max. Apparent Power from Grid [kVA]	43.5	43.5	55.2	55.2	55.2	
	Rated Current to Grid [Aac]	22.8@380V 21.8@400V	30.4@380V 29.0@400V	37.9@380V 36.3@400V	45.5@380V 43.5@400V	45.5@380V 43.5@400V	
	Rated Current from Grid [Aac]	22.8@380V 21.8@400V	30.4@380V 29.0@400V	37.9@380V 36.3@400V	45.5@380V 43.5@400V	45.5@380V 43.5@400V	
	Max. Current to Grid [Aac]	22.8@380V 21.8@400V	30.4@380V 29.0@400V	37.9@380V 36.3@400V	45.5@380V 43.5@400V	45.5@380V 43.5@400V	
	Max. Current from Grid [Aac]	63.0	63.0	80.0	80.0	80.0	
	Power Factor cosφ [λ]	[-0.80. 0.80]					
	Overvoltage Category (OVC)	OVC III					
Back up	Rated Output Voltage Ur [Vac]	220/380, 230/400, 3L/N/PE					
	Rated Output Frequency F <sub>NETZ</sub> [Hz]	50/60					

	Normal Operating Frequency Range $F_n$ [Hz]	45-55 / 55-65				
	Rated Output Apparent Power [kVA]	15	20	25	30	30
	Max. Output Apparent Power* [kVA]	off-grid: 16.5 on-grid: 43.5	off-grid: 22 on-grid: 43.5	off-grid: 27.5 on-grid: 55.2	off-grid: 33 on-grid: 55.2	off-grid: 33 on-grid: 55.2
	Rated Output Current [Aac]	22.8@380V 21.8@400V	30.4@380V 29.0@400V	37.9@380V 36.3@400V	45.5@380V 43.5@400V	45.5@380V 43.5@400V
	Max. Output Current* [Aac]	off-grid: 33.4 on-grid: 63	off-grid: 33.4 on-grid: 63	off-grid: 50.0 on-grid: 80	off-grid: 50.0 on-grid: 80	off-grid: 50.0 on-grid: 80
SYSTEM	Protective Class	I				
	Enclosure Protection (IP)	IP66				
	Operating Temperature Range [°C]	-35 to +60 (>40 derating)				
	Pollution degree (PD)	External PD3/Internal PD 2				
	Max. Operating Altitude [m]	Max. 4000				
	Weight [kg]	30	30	32	32	32
	Size [mm] (W*H*D mm)	800*340*270				
	Type of inverter	Non-isolated				
	Firmware version	010101				
Note: *: "off-grid" means the energy of backup output only comes from battery. "on-grid" means the energy of the backup output includes the energy from grid or generator (on-grid port, connected via an ATS switch) side.						
AFCI Configuration:						
Model	GW5K-ETA-G20, GW6K-ETA-G20, GW8K-ETA-G20	GW9.999K-ETA-G20, GW10K-ETA-G20, GW12K-ETA-G20, GW15K-ETA-G20, GW20K-ETA-G20	GW25K-ETA-G20, GW29.999K-ETA-G20, GW30K-ETA-G20			
Classification	F-I-AFPE-1-2/1-2	F-I-AFPE-1-2/2-2	F-I-AFPE-1-2/4-2			
No. of monitored strings per input port	1					
No. of input ports per channel	2/1	2/2	2/4			
No. of monitored channels	2	2	2			
Rated channel current [Ad.c.]	42/21	42/42	42/84			
Maximum current per input port [Ad.c.]	21					
Rated interruption current [Ad.c.]	21					

**Additional application considerations – (Considerations used to test a component) –**

N/A

### DESCRIPTION OF SAFETY FUNCTION(S)

	Safety function 1 – Grid relay adhesion fault detection	
	Software protection	Hardware protection
Description	Grid relay adhesion fault is detected by sampling the feedback of grid relay voltage. When the relay adhesion is detected, system will stop send PWM and switch off inverter-side relays to disconnect the circuit loop.	-
Class	Class B	-
Input	Grid relay voltage	-
Response time	0.1s	-
Output	The DSP control the inverter-side relays switch off, and report relay adhesion to EMS.	-

	Safety function 2 – NPE relay adhesion fault detection	
	Software protection	Hardware protection
Description	NPE relay adhesion fault is detected by sampling the feedback of NPE relay voltage. When the relay adhesion is detected, system will stop send PWM and switch off inverter-side relays to disconnect the circuit loop.	-
Class	Class B	-
Input	NPE relay voltage	-
Response time	0.1s	-
Output	The DSP control the inverter-side relays switch off, and report relay adhesion to EMS.	-

	Safety function 3 – Arc fault detection	
	Software protection	Hardware protection
Description	The DSP collects arc fault by high level from AFCI circuit, and quickly cut off the circuit by open grid relays when arc fault is detected. If the arc alarm is triggered less than 5 times within 24 hours, it can be automatically cleared. After the 5th arc alarm, inverter will shut down protection. Inverter can only resume normal operation after clearing fault.	-
Class	Class B	-
Input	high level of AFCI circuit	-
Response time	0.1s	-
Output	The DSP control the grid relays switch off.	-

IEC 60730-1 Annex H			
Clause	Requirement + Test	Result - Remark	Verdict
H.5	Information in addition to Table 1 provided:		P
	H.3 - Software sequence documentation; clause: H.9.12.2.9; method: X .....	Considered in software evaluation.	P
	H.4 - Program documentation; clause: H.9.12.2.9, H.9.12.2.11; method: X .....		P
	H.5 - Software fault analysis; clause: H.9.1.2, 13.1.3; method: X .....		P
	H.6 - Software class(es) and structure; This information is not required for class A controls; clause: H.9.12.2, H.9.12.3, H.13.2.2.1, H.13.2.3.1; method: D .....		P
	H.7 - Analytical measures and fault/error control techniques employed; clause: H.9.12.1.2, H.9.12.2.2, H.9.12.2.4; method: X .....		P
	H.8 - Software fault/error detection time(s) for controls with software Classes B or C; clause: H.3.17.10, H.9.12.2.6; method: X .....		P
	H.9 - Control response(s) in case of detected fault/error; clause: H.9.12.2.7; method: X .....		P
	H.10 – Controls subjected to a second fault analysis and declared condition as a result of the second fault; clause H.13.2.3; method: X .....	Class B only consider single fault.	N/A
	H.11 - Fault reaction time; clause H.3.22.2, H.13.2.2.2, H.13.2.2.3, H.13.2.3.2, H.13.2.3.3, H.13.2.4.2, H.13.2.4.3; method: X .....		P
	H.12 - Class or classes of control function(s), clause H.13.2.2, H.13.2.3; method: X .....	Class B	P
	a – For controls declared as entirely class A, the requirements H.3, H.4, H.5, H.7, H.8 and H.9 of Table H.1 are exempted. For controls with software classes B or C, information shall be provided only for the safety-related segments of the software. Information on the non-safety related segments shall be sufficient to establish that they do not influence the safety-related segments.....	Considered in software evaluation.	P

IEC 60730-1 Annex H			
Clause	Requirement + Test	Result - Remark	Verdict
	b – The software sequence shall be documented and, together with the operating sequence of table requirement 46, shall include a description of the control system philosophy, the control flow, data flow and the timings. ....:	Considered in software evaluation.	P
	c - Safety-related data and safety-related segments of the software sequence, the malfunction of which could result in non-compliance with the requirements of Clause 13, 19, 24 and H.25 shall be identified. This identification shall: .....		P
	– Included the operating sequence .....		P
	– Software fault analysis was related to the hardware fault analysis in Clause H.13.2.....:		P
	e - Programming documentation was supplied in a programming design language declared by the manufacturer .....		P
	f – Different software classes applied to different control functions .....	Only class B considered.	N/A
	g - Measures declared are chosen by manufacturer from the requirements of Clauses H.9.12.1.2 to H.9.12.2.4 inclusive.....:		P
H.9	Constructional requirements		P
H.9.12	Controls using software		P
	Controls using software were so constructed that the software did not impair control compliance with the requirements of this standard		P
H.9.12.1	Requirements for the architecture		P
H.9.12.1.1	Control functions with software class B or C use measures to control and avoid software-related faults/errors in safety-related data and safety-related segments of the software, as detailed in H.9.12.1.2 to H.9.12.3 inclusive.	Class B considered	P
H.9.12.1.2	Structure for control functions with software class B or C		P
H.9.12.1.2.1	Control functions with software class C have one of the following structures:		N/A
	– single channel with periodic self-test and monitoring (H.3.16.7)	Class B	N/A

IEC 60730-1 Annex H			
Clause	Requirement + Test	Result - Remark	Verdict
	– dual channel (homogenous) with comparison (H.3.16.3)		N/A
	– dual channel (diverse) with comparison (H.3.16.2)		N/A
H.9.12.1.2.2	Control functions with software class B have one of the following structures:		P
	– single channel with functional test (H.3.16.5)	Used	P
	– single channel with periodic self-test (H.3.16.6)	Used	P
	– dual channel without comparison (H.3.16.1)	Not used	N/A
H.9.12.1.3	Other structure permitted with equivalent level of safety to those in H.9.12.1.2 .....		P
H.9.12.2	Measures to control faults/errors		P
H.9.12.2.1	Redundant memory with comparison provided on two areas of the same component: data stored in different formats		P
H.9.12.2.2	Software class C using dual channel structures with comparison: additional fault/error detection means		N/A
H.9.12.2.3	Software class B or C: means for recognition and control of errors in transmission to external safety-related data paths: Means took into account errors of data, addressing, transmission timing and sequence of protocol		P
H.9.12.2.4	For control with software class B or C, the manufacturer shall provide, within the control, measures to address the fault/errors in safety-related segments and data indicated in Table H.2 and declared in Table H.1, requirement H.5.		P
H.9.12.2.5	Measures others than those specified in H.9.12.2.4 are permitted if they can be shown to satisfy the requirements listed in Table H.2.		P
H.9.12.2.6	Software fault/error detection:		P
	– occur not later than declared time(s), Table H.1, requirement H.8		P
	– acceptability of declared time(s): evaluated during fault analysis of the control		P

IEC 60730-1 Annex H			
Clause	Requirement + Test	Result - Remark	Verdict
H.9.12.2.7	For controls with functions, classified as Class B or C, detection of fault/error:		P
	– results in the response declared in Table H.1, requirement H.9		P
	– for Class C: independent means capable of performing this response provided		N/A
H.9.12.2.8	Class C, dual channel structure, loss of dual channel capability: deemed to be an error		N/A
H.9.12.2.9	Software referenced:		P
	– to relevant parts of the operating sequence		P
	– to the associated hardware functions		P
H.9.12.2.10	Labels used for memory locations are unique		N/A
H.9.12.2.11	Software protected from user alteration of safety-related segments and data		P
H.9.12.2.12	Software and safety-related hardware under its control is initialized to and terminates at a declared state, Table H.1, requirement H.4 .....		P
H.9.12.3	Measures to avoid errors		P
H.9.12.3.1	For controls with software class B or C the measures shown in Figure H.1 to avoid systematic faults are applied		P
	Other methods utilized that incorporate disciplined and structured processes including design and test phases		P
H.9.12.3.2	Specification		P
H.9.12.3.2.1	Software safety requirements		P
H.9.12.3.2.1.1	The specification of the software safety requirements includes:		P
	<ul style="list-style-type: none"> <li>• A description of each safety related function to be implemented, including its response time(s):</li> <li>- functions related to the application including their related software classes</li> <li>- functions related to the detection, annunciation and management of software or hardware faults</li> </ul>		P

IEC 60730-1 Annex H			
Clause	Requirement + Test	Result - Remark	Verdict
	<ul style="list-style-type: none"> <li>A description of interfaces between software and hardware</li> </ul>		P
	<ul style="list-style-type: none"> <li>A description of interfaces between any safety and non-safety related functions</li> </ul>		P
H.9.12.3.2.2	Software architecture		P
H.9.12.3.2.2.1	The description of software architecture includes the following aspects:		P
	<ul style="list-style-type: none"> <li>Techniques and measures to control software faults/errors (refer to H.9.12.2)</li> </ul>		P
	<ul style="list-style-type: none"> <li>Interactions between hardware and software</li> </ul>		P
	<ul style="list-style-type: none"> <li>Partitioning into modules and their allocation to the specified safety functions</li> </ul>		P
	<ul style="list-style-type: none"> <li>Hierarchy and call structure of the modules (control flow)</li> </ul>		P
	<ul style="list-style-type: none"> <li>Interrupt handling</li> </ul>		P
	<ul style="list-style-type: none"> <li>Data flow and restrictions on data access</li> </ul>		P
	<ul style="list-style-type: none"> <li>Architecture and storage of data</li> </ul>		P
	<ul style="list-style-type: none"> <li>Time based dependencies of sequences and data</li> </ul>		P
H.9.12.3.2.2.2	The architecture specification is verified against the specification of the software safety requirements by static analysis		P
H.9.12.3.2.3	Module design and coding		P
H.9.12.3.2.3.1	Software is suitably refined into modules. Software module design and coding are implemented in a way that is traceable to the software architecture and requirements. The module design specified:		P
	– function(s)		P
	– interfaces to other modules		P
	– data		P

IEC 60730-1 Annex H			
Clause	Requirement + Test	Result - Remark	Verdict
H.9.12.3.2.3.2	Software code is structured		P
H.9.12.3.2.3.3	Coded software is verified against the module specification, and the module specification is verified against the architecture specification by static analysis		P
H.9.12.3.2.4	Design and coding standards		P
	Program design and coding standards is used during software design and maintenance		P
	Coding standards .....		P
	– specified programming practice		P
	– proscribed unsafe language features		P
	– specify procedures for source code documentation		P
	– specify data naming conventions		P
H.9.12.3.3	Testing		P
H.9.12.3.3.1	Module design (software system design, software module design and coding)		P
H.9.12.3.3.1.1	A test concept with suitable test cases is defined based on the module design specification.		P
H.9.12.3.3.1.2	Each software module is tested as specified within the test concept		P
H.9.12.3.3.1.3	Test cases, test data and test results are documented		P
H.9.12.3.3.1.4	Code verification of a software module by static means includes such techniques as software inspections, walk-throughs, static analysis and formal proof		P
	Code verification of a software module by dynamic means includes functional testing, white-box testing and statistical testing		P
H.9.12.3.3.2	Software integration testing		P

IEC 60730-1 Annex H			
Clause	Requirement + Test	Result - Remark	Verdict
H.9.12.3.3.2.1	A test concept with suitable test cases is defined based on the architecture design specification		P
H.9.12.3.3.2.2	The software is tested as specified within the test concept		P
H.9.12.3.3.2.3	Test cases, test data and test results are documented		P
H.9.12.3.3.3	Software validation		P
H.9.12.3.3.3.1	A validation concept with suitable test cases is defined based on the software safety requirements specification		P
H.9.12.3.3.3.2	The software is validated with reference to the requirements of the software safety requirements specification as specified within the validation concept		P
	The software is exercised by simulation or stimulation of:		P
	<ul style="list-style-type: none"> <li>input signals present during normal operation</li> </ul>		P
	<ul style="list-style-type: none"> <li>anticipated occurrences</li> </ul>		P
	<ul style="list-style-type: none"> <li>undesired conditions requiring system action</li> </ul>		P
H.9.12.3.3.3.3	Test cases, test data and test results are documented		P
H.9.12.3.4	Other Items		P
H.9.12.3.4.1	Equipment used for software design, verification and maintenance was qualified appropriately and demonstrated to be suitable for purpose in manifold applications		P
H.9.12.3.4.2	Management of software versions: All versions are uniquely identified for traceability		P
H.9.12.3.4.3	Software modification		P
H.9.12.3.4.3.1	Software modifications are based on a modification request which details the following:		P
	<ul style="list-style-type: none"> <li>the hazards which may be affected</li> </ul>		P
	<ul style="list-style-type: none"> <li>the proposed change</li> </ul>		P

IEC 60730-1 Annex H			
Clause	Requirement + Test	Result - Remark	Verdict
	<ul style="list-style-type: none"> <li>the reasons for change</li> </ul>		P
H.9.12.3.4.3.2	An analysis is carried out to determine the impact of the proposed modification on functional safety.		P
H.9.12.3.4.3.3	A detailed specification for the modification is generated including the necessary activities for verification and validation, such as a definition of suitable test cases		P
H.9.12.3.4.3.4	The modification is carried out as planned		P
H.9.12.3.4.3.5	The assessment of the modification is carried out based on the specified verification and validation activities.		P
H.9.12.3.4.3.6	All details of modification activities are documented		P
H.9.12.3.5	For class C control functions: One of the combinations (a–p) of analytical measures given in the columns of table H.10 is used during hardware development.....	Class B	N/A
H.9.12.4	Remotely actuated control functions		N/A
H.9.12.4.2.3.1	Communication of Safety Related Data – Transmission – Safety relevant data is transmitted authentically concerning:		N/A
	– data corruption		N/A
	– address corruption		N/A
	– wrong timing or sequence		N/A
	Data variation or corrupted data did not lead to an unsafe state		N/A
	Before transmitted data was used it was ensured that data corruption, address corruption and wrong timing or sequence are addressed using the measures as given in Annex H.		N/A
	The following failure modes are addressed .....		N/A
	– permanent “auto-sending” or repetition,		N/A
	– interruption of data transfer		N/A

IEC 60730-1 Annex H			
Clause	Requirement + Test	Result - Remark	Verdict
H.9.12.4.2.3.2	Access to data exchange		N/A
	Adequate hardware/software measures are taken to prevent unauthorized access to the control functions (class B and C; operating data, configuration parameters and/or software modules)		N/A
	Access to data exchange of class B control function or class C control function related operating data through public networks, has appropriate cryptographic techniques implemented.		N/A
H.9.12.4.2.3.3	For class B and class C software revisions the requirements of H.9.12.3 and hardware configuration management are applied and the control maintains its protective functions		N/A
H.9.12.4.5	Software Download and Installation		N/A
	Software updates provided by the manufacturer and transmitted to the control via remote communication were checked prior to its use:		N/A
	– against corruption through communication ensuring Hamming distance 3 for software class B, or Hamming distance 4 for software class C;		N/A
	– that the software version is compatible with the hardware version of the control according to the version management documentation.		N/A
	The software which performs the above mentioned checks had measures to control the fault/error conditions specified in H.9.12.2.		N/A
H.9.12.4.5.2	In case of software download via remote communication, the cryptographic techniques in H.9.12.4.6 were provided. In addition to the requirements in H.9.12.4.6, identification procedures were provided for the software packages.		N/A
	The cryptographic techniques employed were part of the control, did not rely upon part of the router or similar data transmission device itself, and were performed prior to transmission.		N/A

IEC 60730-1 Annex H			
Clause	Requirement + Test	Result - Remark	Verdict
H.9.12.4.5.3	Each update of software had provisions for authorization by the user and a version ID number which were accessible.		N/A
H.9.12.4.5.4	The installation of class B software or class C software was permitted during and after which the software installation process the control remained in compliance with the requirements of this standard.		N/A
H.9.12.4.6	Cryptographic techniques		N/A
	In cases where class B control function or class C control function related operating data, configuration parameters and/or software modules were transmitted over a public network, and/or where software updates were provided by the manufacturer via remote communication, cryptographic techniques were employed.		N/A
H.13	Fault assessment on electronic circuits		P
H.13.2	Protection against internal faults to ensure functional safety		P
H.13.2.1	Design and construction requirements		P
H.13.2.1.1	Fault avoidance and fault tolerance		P
	Controls incorporating control functions of class B or C are designed according to H.13.2 taking into account the failure modes of Table 14 and H.9.12 for software		P
	Systematic errors are avoided		P
	Random faults are dealt with by a proper system configuration		P
	Functional analysis of the application resulted in a structured design with:		P
	– Control flow		P
	– Data flow		P
	– Time related functions required by the application		P
	For custom-chips special attention was made to minimize systematic errors		N/A

IEC 60730-1 Annex H			
Clause	Requirement + Test	Result - Remark	Verdict
	System configuration was failsafe or:		P
	Incorporated components with direct safety-critical functions guarded by safeguards that cause a completely independent safety shut-down in accordance to H.9.12 software class B or C		P
	- safeguards are built into hardware and,		P
	- safeguards are supplemented by software		P
	Time slot monitoring is sensitive to both an upper and a lower limit of the time interval.		P
	Faults resulting in a shift of the upper and/or lower limit are taken into account.		P
	In a class C control function when a single fault in a primary safeguard can render the safeguard inoperative, a secondary safeguard is provided		N/A
	The reaction time of the secondary safeguard is in accordance with Clause H.13.2.3.		P
	Components shall be dimensioned on the basis of the worst-case conditions which can arise in the control, as stated by the manufacturer.		
H.13.2.1.2	Documentation		P
	The documentation was based on H.9.12.3		P
H.13.2.2	Class B control function		P
H.13.2.2.1	Design and construction requirements		P
	A class B control function shall be designed such that under single fault conditions it remains in or proceeds to the defined state. A second independent fault is not considered.		P
	Software complies with software class B		P
	The class of control function shall be declared in Table H.1, requirement H.12. The assessment shall be performed according to H.13.2.2.2 and H.13.2.2.3 and under the test conditions and criteria of H.13.2.5.		P
H.13.2.2.2	First fault		P

IEC 60730-1 Annex H			
Clause	Requirement + Test	Result - Remark	Verdict
	Any first fault (see Table 14) in any one component or any one fault together with any other fault arising from that first fault shall result in either: a) the control becoming inoperative with all safety related output terminals de-energized or assuming a status in which they ensure a safe situation;	The safe-state is de-energized with charging/discharging process stops.	P
	b) the control reacting within the fault reaction time (declared in Table H.1, requirement H.11) by proceeding to a defined state, provided that subsequent reset from the defined state under the same fault condition results in the system returning to the same defined state;		P
	c) the control continuing to operate, the fault being identified during the next start-up sequence, the result being a) or b);		P
	d) the control remaining operational in accordance with the safety related functional requirements of the relevant part 2.		P
	For defined state with a mechanical actuator, a test up to but not including the switching contacts is sufficient. If the test of the defined state fails, the system shall proceed to safety shut-down. Frequency of test is given in the relevant part 2. Internal faults on components of the checking circuit are not considered.		P
H.13.2.2.3	Fault introduced during defined state		P
	Whenever the control is in a defined state without an internal fault, the following requirements apply. Any first fault (together with any other fault arising from that fault) in any one component (see Table 14), induced while the control is staying in a defined state, shall result in either: a) the control remaining in a defined state, safety related output terminals remaining deenergized; or		P
	b) the control becoming inoperative with all safety related output terminals remaining deenergized; or		P

IEC 60730-1 Annex H			
Clause	Requirement + Test	Result - Remark	Verdict
	c) the control comes again in operation resulting in a) or b) as mentioned in this clause under the condition that the safety related output terminals are energized not longer than the fault reaction time (declared in Table H.1, requirement H.11). If the cause of the defined state condition no longer remains and the control comes again in operation, it shall operate in accordance with the safety related functional requirements of the relevant part 2.		P
H.13.2.3	Class C control function		N/A
H.13.2.3.1	Design and construction requirements		N/A
	A class C control function shall be designed such that under first and second fault conditions, it remains in or proceeds to the defined state. A third independent fault is not considered.		N/A
	Software complies with software class C		N/A
	The class of control function shall be identified in Table H.1, requirement H.12. The assessment shall be performed according to H.13.2.3.2, H.13.2.3.3 and H.13.2.4 and under the test conditions and criteria of H.13.2.5.		N/A
H.13.2.3.2	First fault		N/A
	Any first fault (see Table 14) in any one component or any one fault together with any other fault arising from that first fault shall result in either: a) the control becoming inoperative with all safety related output terminals de-energized or assuming a status in which they ensure a safe situation;		N/A
	b) the control reacting within the fault reaction time (see Table H.1, requirement H.11) by proceeding to a defined state, provided that subsequent reset from the defined state condition under the same fault condition results in the system returning to the defined state;		N/A
	c) the control continuing to operate, the fault being identified during the next start-up sequence, the result being a) or b);		N/A
	d) the control remaining operational in accordance with the safety related functional requirements of the relevant part 2.		N/A

IEC 60730-1 Annex H			
Clause	Requirement + Test	Result - Remark	Verdict
H.13.2.3.3	Second fault		N/A
	If the assessment of the first fault results in the control remaining operational in accordance with the safety related functional requirements of the relevant part 2 (see H.13.2.3.2 d)), any further independent fault considered together with the first fault shall result in either H.13.2.3.2 a), b), c) or d).		N/A
	During assessment, the second fault shall only be considered to occur: a) either when a start-up sequence has been performed between the first and the second fault, or b) 24 h after the first fault.		N/A
H.13.2.4	Faults during defined state		P
H.13.2.4.1	Whenever the control is in a defined state without an internal fault, an assessment according to H.13.2.4.2 and H.13.2.4.3 shall be performed. Whenever the control is inoperative with all safety related output terminals de-energized or in a status in which they ensure a safe situation, in a defined state with an internal fault, an additional single fault assessment according to H.13.2.4.3 shall be performed.		P
H.13.2.4.2	First fault introduced during defined state		P
	Any first fault (together with any other fault arising from that fault) in any one component (see Table 14), induced while the control is staying in the safety shut-down position, shall result in either: a) the control remaining in a defined state, safety related output terminals remaining deenergized or in a status in which they ensure a safe situation;		P
	b) the control becoming inoperative with all safety related output terminals remaining deenergized or assuming a status in which they ensure a safe situation;		P

IEC 60730-1 Annex H			
Clause	Requirement + Test	Result - Remark	Verdict
	c) the control comes again in operation resulting in a) or b) as mentioned in H.13.2.4.2 under the condition that the safety related output terminals are energized not longer than the fault reaction time (see Table H.1, requirement H.11). If the cause of the original safety shutdown condition no longer remains and the control comes again in operation, it shall operate in accordance with the safety related functional requirements of the relevant part 2 and the second fault assessment shall be carried out in accordance with H.13.2.3.3.		P
H.13.2.4.3	Second fault introduced during defined state		N/A
	Any second fault (together with any other fault arising from that fault) in any one component (see Table 14), induced while the control is staying in the defined state, shall result in either H.13.2.4.2 a), b) or c).		N/A
	During assessment, the second fault shall not be considered to occur within 24 h after the first fault.		N/A
H.13.2.5	Circuit and construction evaluation		N/A
H.13.2.5.3	Assessment		P
	Only the safety related software (software class B and C) as identified according to H.13.2.1.2 were subjected to further assessment		P
H.25	Electromagnetic compatibility (EMC) requirements – Immunity		N/A
H.25.1	General requirements		N/A
	Electronic controls shall be so constructed as to: - withstand the effects of mains-borne perturbations		N/A
	- electromagnetic phenomena which can occur in normal use		N/A
H.25.2	Particular requirements for integrated and incorporated controls with type 2 action		N/A
	For integrated and incorporated controls with type 2 action, compliance is checked by H.25.5 and any other tests of Clause H.25 which are declared in Table H.1, requirement H.1.		N/A
H.25.3	Sample requirement		N/A

IEC 60730-1 Annex H			
Clause	Requirement + Test	Result - Remark	Verdict
	A separate sample, as submitted, may be used for each test. At the option of the control manufacturer, multiple tests can be performed on a single sample.		N/A
H.25.4	Harmonics and interharmonics including mains signalling at AC power port, low frequency immunity tests		N/A
	The control is subjected to mains signals in accordance with IEC 61000-4-13, test level class 2 being applicable.		N/A
	During the test, the control is supplied with rated voltage. The test levels for Class 2 environment according to IEC 61000-4-13:2002, IEC 61000-4-13/AMD1:2009 and IEC 61000-4-13/AMD2:2015, Tables 1 to 4 shall be applied at the AC power port of the EUT. The control is tested under the test conditions as specified in the specific control standard.		N/A
	The following tests are performed in accordance with IEC 61000-4-13:2002, IEC 61000-4-13/AMD1:2009 and IEC 61000-4-13/AMD2:2015, Figure 1a for Class 2 environment:		N/A
	- "Harmonic combination" (IEC 61000-4-13:2002, IEC 61000-4-13/AMD1:2009 and IEC 61000-4-13/AMD2:2015, 8.2.1);		N/A
	- "Meister curve" (IEC 61000-4-13:2002, IEC 61000-4-13/AMD1:2009 and IEC 61000-4-13/AMD2:2015, 8.2.4).		N/A
H.25.5	Voltage dips, voltage interruptions and voltage variations in the power supply network		N/A
	The control shall tolerate voltage dips voltage interruptions and voltage variations in the power supply network.		N/A
H.25.5.1	Voltage dips and interruptions		N/A
H.25.5.1.1	Test levels for voltage dips and interruptions		N/A
	The test values in Table H.13 shall be applied to all the test levels		N/A
H.25.5.1.2	Test procedure for voltage dips and interruptions		N/A

IEC 60730-1 Annex H			
Clause	Requirement + Test	Result - Remark	Verdict
	The test apparatus and procedures shall be as described in IEC 61000-4-11. During the test, the control shall be initially operated at its rated voltage.		N/A
H.25.5.2	Voltage variation test		N/A
	- verify the immunity of the control against voltage change taking place over a short period which can occur due to a change of load or stored energy in local power networks.		N/A
H.25.5.2.1	Test levels for voltage variations		N/A
	The test values in Table H.14 shall be applied to all the test levels.		N/A
H.25.5.2.2	Test procedure		N/A
	The test apparatus and procedures shall be as described in IEC 61000-4-11.		N/A
H.25.6	Test of influence of voltage unbalance		N/A
H.25.6.1	The influence of unbalance in a three-phase voltage system on equipment sensitive to this kind of interference shall be investigated.		N/A
H.25.6.2	Test voltage characteristics		N/A
	A power frequency three-phase voltage shall be applied to the control with the specified unbalance factor.		N/A
H.25.6.3	Test equipment/test generator		N/A
	The test arrangement shall consist of three single-phase auto-transformers, whose outputs are regulated individually, or the like.		N/A
H.25.6.4	Test level		N/A
	The test shall be carried out with an unbalance factor of 2 %.		N/A
H.25.7	Test of the influence of DC in AC networks		N/A
H.25.8	Surge immunity test		N/A
	The control shall tolerate voltage surges on the mains supply and relevant signal terminals.		N/A

IEC 60730-1 Annex H			
Clause	Requirement + Test	Result - Remark	Verdict
	The tests as detailed in Table H.15 shall be applied.		N/A
	The test apparatus and procedure shall be as described in IEC 61000-4-5.		N/A
H.25.9	Electrical fast transient/burst immunity test		N/A
	The control shall tolerate fast transient bursts on the mains supply and on the signal lines.		N/A
	The tests shall be applied as specified in Table H.16.		N/A
	The test apparatus and test procedures shall be as described in IEC 61000-4-4.		N/A
H.25.10	Electrostatic discharge test		N/A
	This test is carried out in accordance with IEC 61000-4-2.		N/A
	The test values shall be applied to test level 3.		N/A
H.25.11	Radio-frequency electromagnetic field immunity		N/A
H.25.11.2.1	At minimum, the test levels in Table H.17 shall be applied.		N/A
H.25.11.2.2	This test shall be carried out in accordance with IEC 61000-4-6.		N/A
H.25.11.3	The control shall tolerate high-frequency signals on the mains supply and relevant signal terminals.		N/A
H.25.11.3.1	Test levels for immunity to radiated electromagnetic fields shall be applied in accordance with Table H.18.		N/A
H.25.11.3.2	This test shall be carried out in accordance with IEC 61000-4-3.		N/A
H.25.12	Test of influence of supply frequency variations		N/A
	The test values in Table H.20 shall be applied.		N/A
	The test apparatus and procedures shall be as described in IEC 61000-4-28.		N/A
H.25.13	Power frequency magnetic field immunity test		N/A

IEC 60730-1 Annex H			
Clause	Requirement + Test	Result - Remark	Verdict
H.25.13.1	The controls which are susceptible to magnetic field such as controls which use Hall-effect devices shall tolerate power-frequency magnetic fields.		N/A
H.25.13.2	The test levels shall be applied in accordance with Table H.21.		N/A
H.25.13.3	The control is supplied at rated voltage. Test equipment, test set-up and test procedure shall be in accordance with IEC 61000-4-8. The control is tested under the test conditions as specified in the relevant part 2.		N/A
H.25.14	Evaluation of compliance		N/A
H.25.14.1	After completion of all the tests of H.25.4 through H.25.13, the sample(s) shall meet the requirements of Clause 6, Clause 11 and 19.5.		N/A
H.25.14.2	The control shall meet the following:		N/A
	- the requirements of 19.14 or		N/A
	- the output(s) and functions shall be as declared in Table H.1, requirements H.1 and H.2.		N/A
H.25.14.3	Different outputs and functions can be declared by the manufacturer after testing at test level 2, or test level 3, if relevant. Part 2 may specify particular criteria after each of these tests.		N/A
H.25.14.4	In cases where the compliance criteria is not specified for the control, the control shall comply with one of the following criteria:		N/A
	a) normal performance with no loss of protective functions and control is within specification or declared limits;		N/A
	b) loss of protective function within declared limits;		N/A
	c) loss of protective function with safety shut-down.		N/A

<b>TABLE H.1 – MEASURES TO ADDRESS FAULT/ERRORS (Software Class B)</b>			
Component	Fault / Error	Declared measures	Verdict
1. CPU	-	-	-
1.1 Registers	Stuck at	Static memory test	P
1.3 Program counter	Stuck at	Periodic self-test	P
2. Interrupt handling and execution	No interrupt	Time-slot monitoring	P
	Too frequent interrupt	Time-slot monitoring	P
3. Clock	Wrong frequency (for quartz synchronized clock: harmonics/ sub-harmonics only)	Frequency monitoring	P
4. Memory	-	-	-
4.1 Invariable memory	All single bit faults	CRC – single word	P
4.2 Variable memory	DC fault	Static memory test	P
4.3. Addressing (relevant to variable and invariable memory)	Stuck at	The same as item 4.1 and 4.2.	P
5. Internal data path	-	-	-
5.1 Data	Stuck at	CRC – double word	P
5.2 Addressing	Wrong address	CRC – double word	P
6. External communication	-	-	-
6.1 Data	Hamming distance 3	CRC – 16	P
6.2 Addressing	Wrong address	CRC – single word	P
6.3 Timing	Wrong point in time	CRC – single word	P
	Wrong sequence	CRC – single word	P
7. Input/output periphery	-	-	-
7.1 Digital I/O	Fault conditions specified in Cl.H.27	Plausibility check	P
7.2 Analog I/O	-	-	-
7.2.1 A/D and D/A-converter	Fault conditions specified in Cl. H.27	Plausibility check	P
7.2.2 Analog multiplexer	Wrong addressing	N/A No such part	N/A

9. Custom chips e.g. ASIC, GAL, gate array	Any output outside the static and dynamic functional specification	N/A No such part	N/A
--	--	---------------------	-----

<b>Table: Manufacturer's Documentation Referenced in this TRF (informative)</b>		
Title	Revision (#/Letter)	Date
Risk assessment of Safety function - ESA	1.0	20251114
Software evaluation_IEC 60730-1 Annex H_ESA(v00)	1.0	20251114

- End of Test Report -