

Data Sheet | Item Number: 216-1543

Twin ferrule; insulated; black

<https://www.wago.com/216-1543>

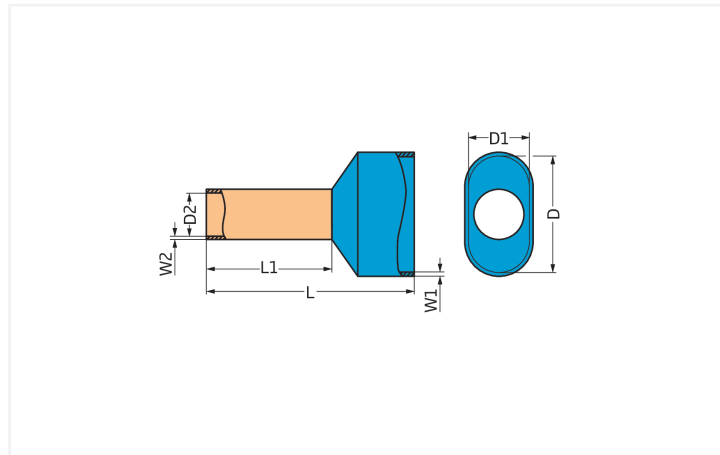

Color: ■ black

Similar to illustration

Connection data

Strip length	13.5 ... 14.5 mm / 0.53 ... 0.57 inches
Metric cross-section of the twin ferrule	1.5 mm ²
Cross-section (AWG) of twin ferrule	2 x 16 AWG

Physical data

Total length	20 mm
Wall thickness of crimp sleeve	0.15 mm
Wall thickness (plastic collar)	0.3 mm
Inner dimension of small plastic collar	3.6 mm
Inner dimension plastic collar large	6.5 mm
Crimp length (length of sleeve)	12 mm
Diameter crimp sleeve inside	2.35 mm

Mechanical data

Plastic collar	Standard collar
----------------	-----------------

Material data

Color	black
Fire load	0 MJ
Weight	0.2 g

Commercial data

PU (SPU)	1000 pcs
Packaging type	Bag
Country of origin	DE
GTIN	4055143642811
Customs tariff number	85369010000

Product Classification

UNSPSC	39121405
ETIM 9.0	EC000005
ETIM 10.0	EC000005
ECCN	NO US CLASSIFICATION

Environmental Product Compliance

RoHS Compliance Status	Compliant, No Exemption
------------------------	-------------------------

Downloads

Environmental Product Compliance

Compliance Search
Environmental Product Compliance 216-1543 

Installation Notes

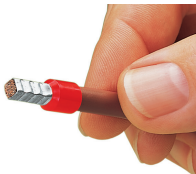

A perfect gas-tight crimp – both electrical-ly and mechanically reliable