



# Aquadis+

Excellence in volumetric water metering

With more than twenty million units installed worldwide, a new release of Aquadis+ has been conceived to exceed accuracy and reliability for all residential applications.

## FEATURES AND BENEFITS

- » Proven long-term performance: with unchanged design and materials of the unique measuring chamber architecture, Aquadis+ maintains high efficiency and maximises the water volume measured over time.
- » New design features include
  - Improved magnetic transmission: with focus on very low flow detection and measurement, Aquadis+ can now reach a dynamic range of R800 in all positions (Q3 2,5 m<sup>3</sup>/h), in compliance with the latest edition of ISO4064 standard.
  - Enlarged cover and new look: wider cover to guarantee legal marking regulatory compliance

## Complete portfolio

- » Aquadis+ is available in several variants to fit the majority of worldwide installations and conditions of use
  - DN 15 and 20 mm in-line body, several lengths available
  - DN 15 and DN20 manifold (concentric)
  - Body in brass and composite materials
  - Registers in plastic with wiper and optional mineral glass version for tough environment

## Smart Metering

Aquadis+ is smart metering ready, making it possible to mount a plug-and-play Cyble communicating module at any time.

## Approvals and Standards

- » Aquadis+ is approved as a measuring instrument for billing applications according with:
  - MID, Directive 2014/32/EU of the European Parliament
  - International Standard EN ISO 4064
  - Recommendations OIML R49
- » Aquadis+ is compliant with regulations for products to be used in contact with water intended for human consumption.
  - ACS (France)
  - WRAS (United Kingdom)
  - Belgaqua (Belgium)
  - Kiwa (Netherlands)
  - KTW - DVGW W270 (Germany)
  - DM174 (Italy) (non-exhaustive list)
- » Aquadis+ is compliant with the directive (2011/65/EU) for Restriction on Hazardous Substances - RoHS2

**PRODUCT CHARACTERISTICS**

Aquadis+ is a volumetric water meter with piston principle combined with the well-known Itron extra-dry register technology.

No parts of the register are in contact with the water flow.

**1 Hermetically Sealed Register\* (Counter)**

Glass lens and copper-can register, condensation and water proof (IP 68), allows permanent readability

\* option for plastic case, for specific applications

**2 Ready for reliable smart metering**

Cyble target with the proven Cyble technology allows to create a reliable digital signal enabling smart water metering

**3 Robust Case**

Brass or thermoplastic material  
High resistance to pressure

**4 Effective and Easy - Maintenance Filter**

Designed to contain major particles, easy to clean

**5 Back-Flow prevention**

All in-line body versions are compatible with a non-return spring type valve

**6 Outstanding Accuracy and Long Term Performance**

Hydro-dynamically balanced piston obtained by a unique design of measuring elements enables detection of extremely low flows and also long-lasting accuracy

**7 Enhanced magnetic transmission**

Optimize low flow accuracy and aging

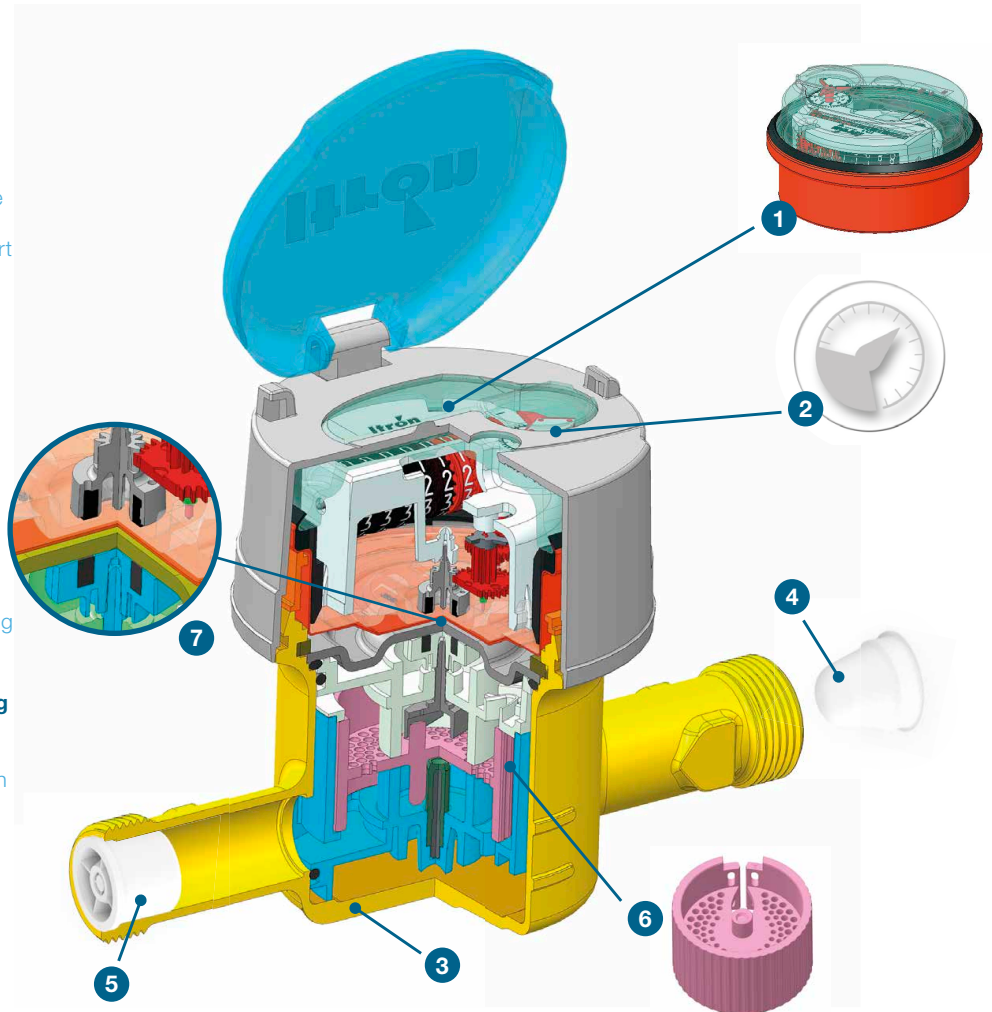

Brass, In-line version

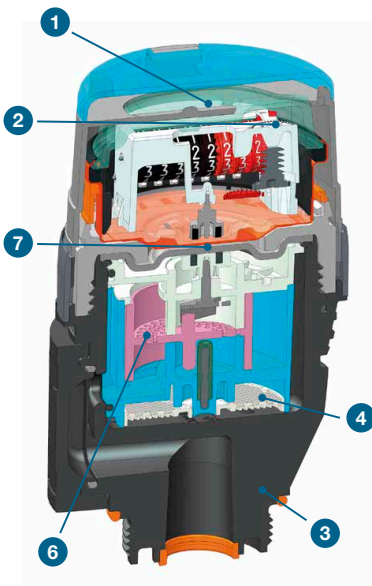

Composite, manifold version

**KEY ADVANTAGES OF COMPOSITE MATERIAL**

- » Lighter (30% less of brass) and ergonomic
- » More suitable to be used with potable water (lead free)
- » Not affected by corrosion (desincification immunity)
- » No value for theft

**MATERIAL CHARACTERISTICS**

- » Reinforced polymer fiber glass
- » High resistance to chemicals
- » High dimensional stability to temperature
- » Robustness to handling and installation

### Technical Specifications

Nominal Diameter (DN)	mm	15 or 20	20
	inches	1/2" or 3/4"	3/4"

### In compliance with MID

MID Accuracy Ratio (Q3/Q1) - all positions			50 / 800	63 / 400		
MID Type Approval Number			LNE 34003	LNE 16467		
Nominal Flow Rate	(Q3)	m <sup>3</sup> /h	1.6	2.5	2.5	4.0
Standard Production Ratio (*)	(Q3/Q1)		100	160	100	160
Minimum Flow Rate	(Q1)	l/h	16	15.6	25	25
Transitional Flow Rate	(Q2)	l/h	25.6	25	40	40
Overload Flow Rate	(Q4)	m <sup>3</sup> /h	2	3.125	3.1	5
Pressure Loss Class at Q3		bar	0.25	0.63	0.25	0.63
Maximum Admissible Pressure (MAP)		bar	16		16	
Operating Temperature (T)		°C	0.1 / 50		0.1 / 50	
Climatic Environment		°C	5 / 55		5 / 55	

(\*) Other Ratios available under specific request

### Other Characteristics

Indication Range	m <sup>3</sup>	99999,999	99999,999
Minimum Scale Interval	l	0.02	0.02
Typical Starting Flow Rate	l/h	1	2
Accuracy +/- 5%	l/h	3	5
Accuracy +/- 2%	l/h	5	8
Testing Pressure	bar	25	25
Maximum Accidental Water Temperature	°C	60 (<1h/week)	60 (<1h/week)



Aquadis+ Register available in plastic and mineral glass versions



Aquadis+ DN20

### HEAD LOSS

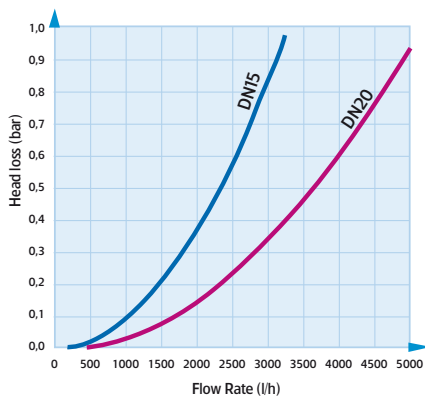

### TYPICAL ACCURACY CURVE ACCORDING WITH R160 ISO 4064 CHANNEL

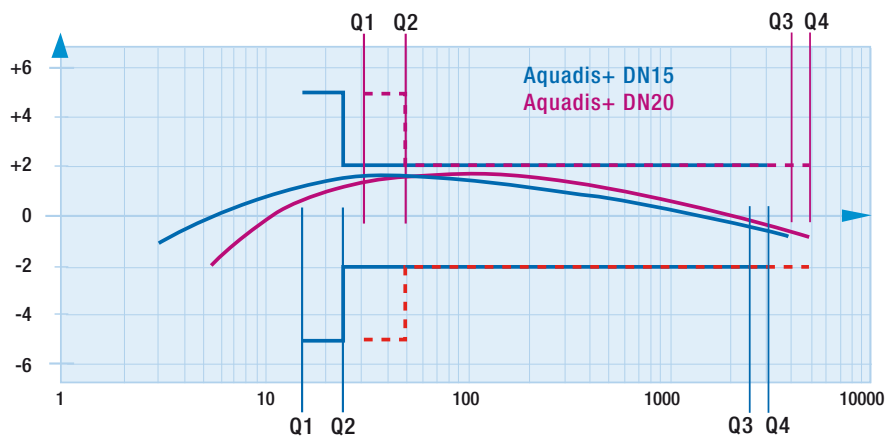

The dynamic range is defined as the ratio (R) between the nominal and the minimum flowrates.



Aquadis+ Composite

## Dimensions

Nominal Diameter	mm	15 or 20	20
Meter Thread	inches	G 3/4	G 1"
	mm	20 x 27	26 x 34
A	mm	105/110/115/ 134/165/170	130/165/190
B	mm	115	143
C	mm	21	20
D	mm	88	88
E	mm	68	70
F	mm	157	186
<b>Manifold</b>		Q3=2.5m <sup>3</sup> /h	Q3=4m <sup>3</sup> /h
A'	mm	90	101
B'	mm	148	159
C'	mm	47	50.5
D'	mm	88	101
E'	mm	147	157
F'	mm	190	201

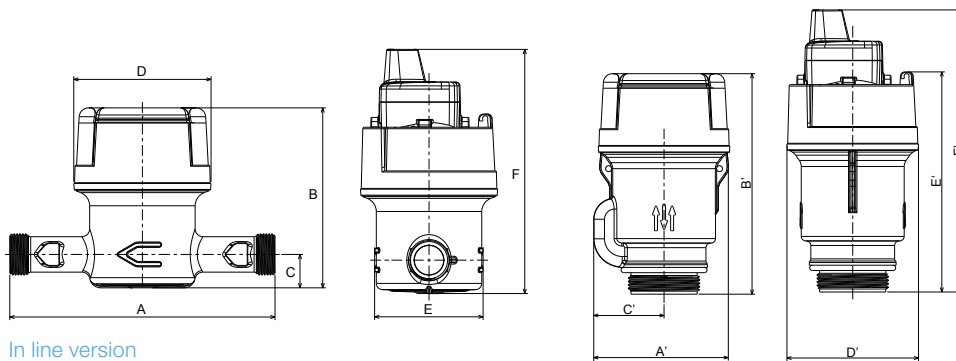

In line version

Manifold version



Cyble RF (wireless, radio frequency)

## CYBLE TECHNOLOGY

This proven technology for smart metering allows to mount a Cyble module on a water meter and has the following key advantages:

- » Simple & robust installation by clip-in (either pre-installation or retrofit)
- » Perfect correlation of the digital index
- » Reliable electronic detection principle (no wear or bounce)
- » Not sensitive to magnetic fields (reduce risk of tampering)

## OPTION

Aquadis+ meters may be fitted with:

- » Cyble modules from the factory
- » Non return-valve for outlet pipe (EN 13959)
- » Removable cap
- » Connection set (delivered separately)

## SMART METERING SOLUTIONS

Cyble modules allow communication through a large range of advanced and reliable data collection solutions (AMR & AML), along with a rich dataset.

- » Walk-by & Drive-By Systems
- » Radian Fixed Network
- » M-Bus & wireless M-Bus systems (OMS)
- » LoRaWAN & Sigfox networks dedicated to the IoT (Cyble4IoT)
- » Systems based on universal pulse outputs



Wired Cyble (Sensor & M-Bus)



Aquadis+ equipped with cyble 4IoT



Join us in creating a more **resourceful world**.  
To learn more visit **itron.com**

While Itron strives to make the content of its marketing materials as timely and accurate as possible, Itron makes no claims, promises, or guarantees about the accuracy, completeness, or adequacy of, and expressly disclaims liability for errors and omissions in, such materials. No warranty of any kind, implied, expressed, or statutory, including but not limited to the warranties of non-infringement of third party rights, title, merchantability, and fitness for a particular purpose, is given with respect to the content of these marketing materials. © Copyright 2018 Itron. All rights reserved. **WA-0115.1-EN-07.18**

## ITRON WATER METERING

9, rue Ampère  
71031 Mâcon cedex  
France

**Phone:** +33 3 85 29 39 00

**Fax:** +33 3 85 29 38 58