

**Klappenhebel für NF..A / SF..A**

- für 3/4" Achsen
- (Klemmbereich Rundachsen 10...22 mm)

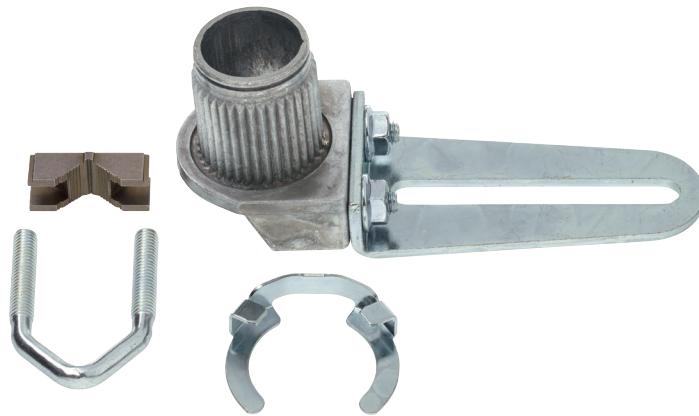

**Technische Daten**

<b>Gewicht</b>	Gewicht	0.21 kg
	Verpackungsgröße	Einzelverpackung

**Produktmerkmale**

<b>Verwendete Materialien</b>	Zinkdruckguss Stahl verzinkt
<b>Anwendung</b>	Passend zu NF..A, SF..A

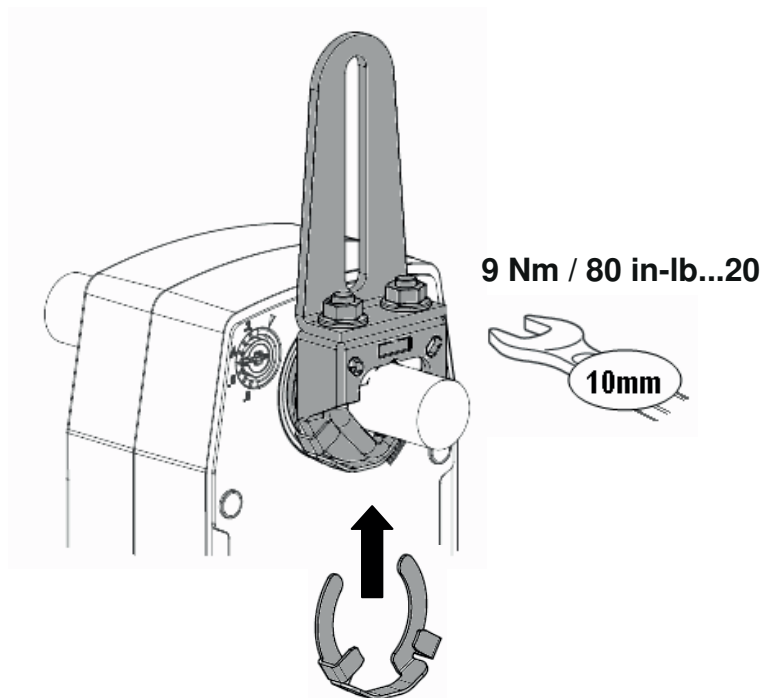

	●	■	◆
mm	10...20 <sup>1)</sup>	≥ 10	≤ 20
inch	3/8...3/4 <sup>1)</sup>	≥ 3/8	≤ 3/4

<sup>1)</sup>CrNi (INOX) 12...20 / 1/2"...3/4"

## Abmessungen [mm]

Massbilder

