

Data Sheet | Item Number: 226-101

Feedthrough terminal block; Conductor/solder/crimp quick disconnect terminal;
Plate thickness: 1.5 mm; 4 mm²; Pin spacing 6 mm; 1-pole; CAGE CLAMP®; 4,00
mm²; gray

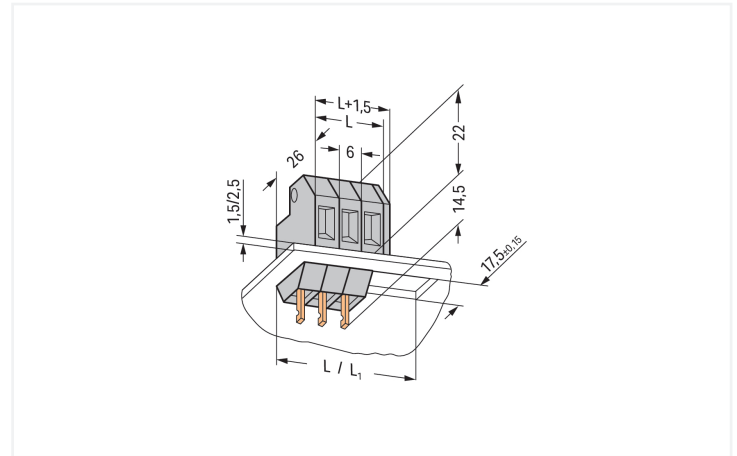

<https://www.wago.com/226-101>



Color: ■ gray

Similar to illustration

Dimensions in mm
L = pole no. x 6 mm L1 = L + 1.5 mm

Feedthrough terminal block, 226 Series, solder pin dimensions 2.8 x 0.8 mm

Enjoy seamless electrical installations with feedthrough terminal block (item number 226-101). Conductors can only be connected to feedthrough terminal block if their strip length is between 9 and 10 mm. This product features two conductor terminals and utilizes CAGE CLAMP® and a solder connection. Our trusted universal connection known as CAGE CLAMP® is the industry standard for connection technology and electrical interconnections. The item's dimensions are (6 x 36.5 x 26) mm (width x height x depth). Feedthrough terminal block is suitable for conductor cross sections ranging from 0.08 mm² to 4 mm².

The contact surface is coated with tin.

Electrical data

Ratings	Solder connection		
Ratings per	IEC/EN 60664-1	IEC/EN 60664-1	IEC/EN 60664-1
Overvoltage category	III	III	II
Pollution degree	3	2	2
Nominal voltage	320 V	320 V	630 V
Rated impulse withstand voltage	4 kV	4 kV	4 kV
Rated current	20 A	20 A	20 A

Ratings	Quick connect contact		
Ratings per	IEC/EN 60664-1	IEC/EN 60664-1	IEC/EN 60664-1
Overvoltage category	III	III	II
Pollution degree	3	2	2
Nominal voltage	320 V	320 V	630 V
Rated impulse withstand voltage	4 kV	4 kV	4 kV
Rated current	6 A	6 A	6 A

Approvals per	UL 1059		
Use group	B	C	D
Rated voltage	300 V	300 V	600 V
Rated current	6 A	6 A	5 A

Approvals per	CSA		
Use group	B	C	D
Rated voltage	300 V	300 V	600 V
Rated current	6 A	6 A	5 A

Connection Data

Clamping units	1
Total number of potentials	1
Number of connection types	2
Number of levels	1

Connection 1

Connection technology	CAGE CLAMP®
Number of connection points	1
Actuation type	Operating tool
Solid conductor	0.08 ... 4 mm ² / 28 ... 12 AWG
Fine-stranded conductor	0.08 ... 4 mm ² / 28 ... 12 AWG
Fine-stranded conductor; with insulated ferrule	0.25 ... 2.5 mm ²
Fine-stranded conductor; with uninsulated ferrule	0.25 ... 2.5 mm ²
Strip length	9 ... 10 mm / 0.35 ... 0.39 inches
Pole number	1

Connection 2

Connection technology	Solder connection
Number of connection points	1

Connection 3

Connection technology	Quick-connect contact
-----------------------	-----------------------

Physical data

Pin spacing	6 mm / 0.236 inches
Width	6 mm / 0.236 inches
Height	36.5 mm / 1.437 inches
Height from the surface	22 mm / 0.866 inches
Depth	26 mm / 1.024 inches
Solder pin dimensions	2.8 x 0.8 mm

Mechanical data

Housing sheet thickness	1.5 ... 1.5 mm / 0.059 ... 0.059 inches
Mounting type	Snap-in foot
Mounting type	Feed-through mounting
Suitable for through-panel applications	Yes

Material data

Note (material data)	Information on material specifications can be found here
Color	gray
Material group	I
Insulation material (main housing)	Polyamide (PA66)
Flammability class per UL94	V0
Clamping spring material	Chrome-nickel spring steel (CrNi)
Contact material	Electrolytic copper (E _{Cu})
Contact Plating	Tin
Fire load	0.054 MJ
Weight	3.4 g

Environmental requirements

Limit temperature range	-60 ... +105 °C
-------------------------	-----------------

Commercial data

Product Group	4 (Printed Circuit Connectors)
PU (SPU)	200 pcs
Packaging type	Box
Country of origin	DE
GTIN	4044918794350
Customs tariff number	85369010000

Product Classification

UNSPSC	39121409
eCl@ss 10.0	27-14-11-34
eCl@ss 9.0	27-14-11-34
ETIM 9.0	EC001283
ETIM 10.0	EC001283
ECCN	NO US CLASSIFICATION

Environmental Product Compliance

RoHS Compliance Status	Compliant, No Exemption
------------------------	-------------------------

Approvals / Certificates

General approvals



Approval	Standard	Certificate Name
CSA DEKRA Certification B.V.	C22.2	70010891
UL UL International Germany GmbH	UL 1059	E45172

Downloads

Environmental Product Compliance

Compliance Search

Environmental Product
Compliance 226-101



Documentation

Additional Information

Technical Section	03.04.2019	pdf 2027.26 KB	↓
-------------------	------------	-------------------	-------------------

CAD/CAE-Data

CAD data

2D/3D Models 226-101	↓
----------------------	-------------------

CAE data

EPLAN Data Portal 226-101	↓
WSCAD Universe 226-101	↓
ZUKEN Portal 226-101	↓

1 Compatible Products

1.1 Required Accessories

1.1.1 End plate

1.1.1.1 End plate



Item No.: 226-120

End plate; for 400 V, cut-out dimensions L1; 1.5 mm thick; gray



Item No.: 226-110

End plate; for 630 V, cut-out dimensions L1; 1.5 mm thick; gray

1.1.2 Installation

1.1.2.1 Intermediate plate



Item No.: 226-109

Spacer; for plate thickness 1.5 mm; 6 mm wide; gray



Item No.: 226-119

Spacer; for plate thickness 2.5 mm; 6 mm wide; gray

1.2 Optional Accessories

1.2.1 Ferrule

1.2.1.1 Ferrule



Item No.: 216-241

Ferrule; Sleeve for 0.5 mm² / 20 AWG; insulated; electro-tin plated; electrolytic copper; gastight crimped; acc. to DIN 46228, Part 4/09.90; white



Item No.: 216-141

Ferrule; Sleeve for 0.5 mm² / 20 AWG; un-insulated; electro-tin plated; electrolytic copper; gastight crimped; acc. to DIN 46228, Part 1/08.92



Item No.: 216-242

Ferrule; Sleeve for 0.75 mm² / 18 AWG; insulated; electro-tin plated; electrolytic copper; gastight crimped; acc. to DIN 46228, Part 4/09.90; gray



Item No.: 216-262

Ferrule; Sleeve for 0.75 mm² / 18 AWG; insulated; electro-tin plated; electrolytic copper; gastight crimped; acc. to DIN 46228, Part 4/09.90; gray



Item No.: 216-142

Ferrule; Sleeve for 0.75 mm² / 18 AWG; un-insulated; electro-tin plated; electrolytic copper; gastight crimped; acc. to DIN 46228, Part 1/08.92



Item No.: 216-243

Ferrule; Sleeve for 1 mm² / AWG 18; insulated; electro-tin plated; electrolytic copper; gastight crimped; acc. to DIN 46228, Part 4/09.90; red



Item No.: 216-263

Ferrule; Sleeve for 1 mm² / AWG 18; un-insulated; electro-tin plated; electrolytic copper; gastight crimped; acc. to DIN 46228, Part 4/09.90; red



Item No.: 216-143

Ferrule; Sleeve for 1 mm² / AWG 18; un-insulated; electro-tin plated; electrolytic copper; gastight crimped; acc. to DIN 46228, Part 1/08.92

1.2.1.1 Ferrule



Item No.: 216-244

Ferrule; Sleeve for 1.5 mm² / AWG 16; insulated; electro-tin plated; electrolytic copper; gastight crimped; acc. to DIN 46228, Part 4/09.90; black

Item No.: 216-264

Ferrule; Sleeve for 1.5 mm² / AWG 16; insulated; electro-tin plated; electrolytic copper; gastight crimped; acc. to DIN 46228, Part 4/09.90; black

Item No.: 216-284

Ferrule; Sleeve for 1.5 mm² / AWG 16; insulated; electro-tin plated; electrolytic copper; gastight crimped; acc. to DIN 46228, Part 4/09.90; black

Item No.: 216-144

Ferrule; Sleeve for 1.5 mm² / AWG 16; un-insulated; electro-tin plated; electrolytic copper; gastight crimped; acc. to DIN 46228, Part 1/08.92; silver-colored



Item No.: 216-246

Ferrule; Sleeve for 2.5 mm² / AWG 14; insulated; electro-tin plated; electrolytic copper; gastight crimped; acc. to DIN 46228, Part 4/09.90; blue

Item No.: 216-266

Ferrule; Sleeve for 2.5 mm² / AWG 14; insulated; electro-tin plated; electrolytic copper; gastight crimped; acc. to DIN 46228, Part 4/09.90; blue

Item No.: 216-286

Ferrule; Sleeve for 2.5 mm² / AWG 14; insulated; electro-tin plated; electrolytic copper; gastight crimped; acc. to DIN 46228, Part 4/09.90; blue

Item No.: 216-106

Ferrule; Sleeve for 2.5 mm² / AWG 14; un-insulated; electro-tin plated; silver-colored

1.2.2 Test and measurement

1.2.2.1 Testing accessories



Item No.: 210-136

Test plug; 2 mm Ø; with 500 mm cable; red

1.2.3 Tool

1.2.3.1 Operating tool



Item No.: 210-720

Operating tool; Blade: 3.5 x 0.5 mm; with a partially insulated shaft; multicoloured

Item No.: 210-657

Operating tool; Blade: 3.5 x 0.5 mm; with a partially insulated shaft; short; multicoloured

Installation Notes

Installation

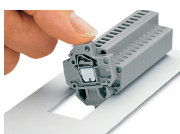

Snapping a feedthrough terminal block (226 Series) into the cutout.

Testing

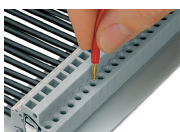

Testing with 2 mm Ø test plug – touch contact.

Subject to changes. Please also observe the further product documentation!

Current addresses can be found at: www.wago.com