

## Data Sheet | Item Number: 226-103

Feedthrough terminal block; Conductor/contact pin; Plate thickness: 2.5 mm; 4 mm<sup>2</sup>; Pin spacing 6 mm; 1-pole; CAGE CLAMP®; 4,00 mm<sup>2</sup>; gray

<https://www.wago.com/226-103>

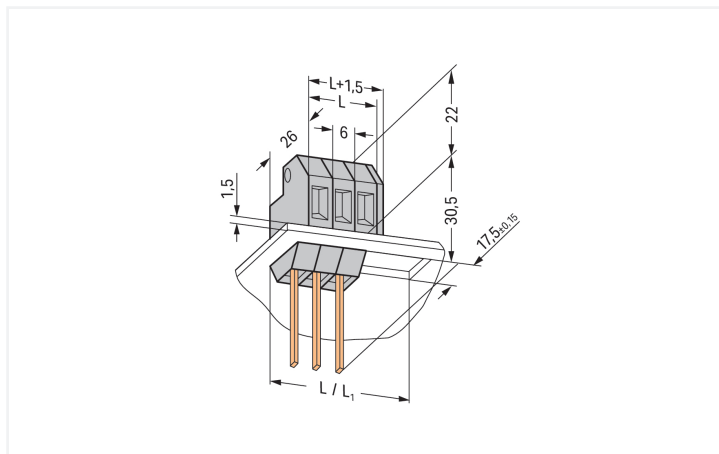

Color: ■ gray

Similar to illustration

Dimensions in mm  
L = pole no. x 6 mm L<sub>1</sub> = L + 1.5 mm

Feedthrough terminal block, 226 Series, operating tool

Effortless electrical installations are guaranteed with feedthrough terminal block (item number 226-103). Conductors can only be connected to feedthrough terminal block if their strip length is between 9 and 10 mm. Featuring two conductor terminals along with CAGE CLAMP® as well as Contact pin, this product delivers reliable performance. Our CAGE CLAMP® connection provides a reliable and maintenance-free way to connect all types of conductors. You do not need to prepare the conductor in any way, such as crimping ferrules. The dimensions are (6 x 38.5 x 26) mm (width x height x depth). Feedthrough terminal block is suitable for conductor cross sections ranging from 0.08 mm<sup>2</sup> to 4 mm<sup>2</sup>.

Tin is used for coating the contact surfaces.

### Electrical data

Ratings	Contact pin		
	IEC/EN 60664-1	IEC/EN 60664-1	IEC/EN 60664-1
Ratings per			
Overvoltage category	III	III	II
Pollution degree	3	2	2
Nominal voltage	320 V	320 V	630 V
Rated impulse withstand voltage	4 kV	4 kV	4 kV
Rated current	4 A	4 A	4 A

Approvals per	UL 1059		
	B	C	D
Use group			
Rated voltage	300 V	300 V	600 V
Rated current	4 A	4 A	4 A

Approvals per	CSA		
	B	C	D
Use group			
Rated voltage	300 V	300 V	600 V
Rated current	4 A	4 A	4 A

## Connection Data

Clamping units	1
Total number of potentials	1
Number of connection types	2
Number of levels	1

### Connection 1

Connection technology	CAGE CLAMP®
Number of connection points	1
Actuation type	Operating tool
Solid conductor	0.08 ... 4 mm <sup>2</sup> / 28 ... 12 AWG
Fine-stranded conductor	0.08 ... 4 mm <sup>2</sup> / 28 ... 12 AWG
Fine-stranded conductor; with insulated ferrule	0.25 ... 2.5 mm <sup>2</sup>
Fine-stranded conductor; with uninsulated ferrule	0.25 ... 2.5 mm <sup>2</sup>
Strip length	9 ... 10 mm / 0.35 ... 0.39 inches
Pole number	1

### Connection 2

Connection technology	Contact pin
Number of connection points	1

## Physical data

Pin spacing	6 mm / 0.236 inches
Width	6 mm / 0.236 inches
Height	38.5 mm / 1.516 inches
Height from the surface	22 mm / 0.866 inches
Depth	26 mm / 1.024 inches

## Mechanical data

Housing sheet thickness	1.5 ... 1.5 mm / 0.059 ... 0.059 inches
Mounting type	Snap-in foot
Mounting type	Feed-through mounting
Suitable for through-panel applications	Yes

## Material data

Note (material data)	<a href="#">Information on material specifications can be found here</a>
Color	gray
Material group	I
Insulation material (main housing)	Polyamide (PA66)
Flammability class per UL94	V0
Clamping spring material	Chrome-nickel spring steel (CrNi)
Contact material	Electrolytic copper (E <sub>Cu</sub> )
Contact Plating	Tin
Fire load	0.054 MJ
Weight	3.5 g

### Environmental requirements

Limit temperature range	-60 ... +105 °C
-------------------------	-----------------

### Commercial data

Product Group	4 (Printed Circuit Connectors)
PU (SPU)	150 pcs
Packaging type	Bag
Country of origin	DE
GTIN	4044918794367
Customs tariff number	85369010000

### Product Classification

UNSPSC	39121409
eCl@ss 10.0	27-14-11-34
eCl@ss 9.0	27-14-11-34
ETIM 9.0	EC001283
ETIM 10.0	EC001283
ECCN	NO US CLASSIFICATION

### Environmental Product Compliance

RoHS Compliance Status	Compliant, No Exemption
------------------------	-------------------------

### Approvals / Certificates

#### General approvals



Approval	Standard	Certificate Name
CSA DEKRA Certification B.V.	C22.2	70010891
UL UL International Germany GmbH	UL 1059	E45172

### Downloads

#### Environmental Product Compliance

##### Compliance Search

Environmental Product  
Compliance 226-103



## Documentation

### Additional Information

Technical Section	03.04.2019	pdf 2027.26 KB	<a href="#">↓</a>
-------------------	------------	-------------------	-------------------

## CAD/CAE-Data

CAD data	CAE data
2D/3D Models 226-103 <a href="#">↓</a>	EPLAN Data Portal 226-103 <a href="#">↓</a>
	WSCAD Universe 226-103 <a href="#">↓</a>

## 1 Compatible Products

### 1.1 Required Accessories

#### 1.1.1 End plate

##### 1.1.1.1 End plate



**Item No.: 226-120**

End plate; for 400 V, cut-out dimensions L1; 1.5 mm thick; gray



**Item No.: 226-110**

End plate; for 630 V, cut-out dimensions L1; 1.5 mm thick; gray

### 1.1.2 Installation

#### 1.1.2.1 Intermediate plate



**Item No.: 226-109**

Spacer; for plate thickness 1.5 mm; 6 mm wide; gray



**Item No.: 226-119**

Spacer; for plate thickness 2.5 mm; 6 mm wide; gray

## 1.2 Optional Accessories

### 1.2.1 Ferrule

#### 1.2.1.1 Ferrule



**Item No.: 216-241**

Ferrule; Sleeve for 0.5 mm<sup>2</sup> / 20 AWG; insulated; electro-tin plated; electrolytic copper; gastight crimped; acc. to DIN 46228, Part 4/09.90; white



**Item No.: 216-141**

Ferrule; Sleeve for 0.5 mm<sup>2</sup> / 20 AWG; un-insulated; electro-tin plated; electrolytic copper; gastight crimped; acc. to DIN 46228, Part 1/08.92



**Item No.: 216-242**

Ferrule; Sleeve for 0.75 mm<sup>2</sup> / 18 AWG; insulated; electro-tin plated; electrolytic copper; gastight crimped; acc. to DIN 46228, Part 4/09.90; gray



**Item No.: 216-262**

Ferrule; Sleeve for 0.75 mm<sup>2</sup> / 18 AWG; un-insulated; electro-tin plated; electrolytic copper; gastight crimped; acc. to DIN 46228, Part 4/09.90; gray



**Item No.: 216-142**

Ferrule; Sleeve for 0.75 mm<sup>2</sup> / 18 AWG; un-insulated; electro-tin plated; electrolytic copper; gastight crimped; acc. to DIN 46228, Part 1/08.92



**Item No.: 216-243**

Ferrule; Sleeve for 1 mm<sup>2</sup> / AWG 18; un-insulated; electro-tin plated; electrolytic copper; gastight crimped; acc. to DIN 46228, Part 4/09.90; red



**Item No.: 216-263**

Ferrule; Sleeve for 1 mm<sup>2</sup> / AWG 18; un-insulated; electro-tin plated; electrolytic copper; gastight crimped; acc. to DIN 46228, Part 4/09.90; red



**Item No.: 216-143**

Ferrule; Sleeve for 1 mm<sup>2</sup> / AWG 18; un-insulated; electro-tin plated; electrolytic copper; gastight crimped; acc. to DIN 46228, Part 1/08.92

### 1.2.1.1 Ferrule



**Item No.: 216-244**

Ferrule; Sleeve for 1.5 mm<sup>2</sup> / AWG 16; insulated; electro-tin plated; electrolytic copper; gastight crimped; acc. to DIN 46228, Part 4/09.90; black



**Item No.: 216-264**

Ferrule; Sleeve for 1.5 mm<sup>2</sup> / AWG 16; insulated; electro-tin plated; electrolytic copper; gastight crimped; acc. to DIN 46228, Part 4/09.90; black



**Item No.: 216-284**

Ferrule; Sleeve for 1.5 mm<sup>2</sup> / AWG 16; insulated; electro-tin plated; electrolytic copper; gastight crimped; acc. to DIN 46228, Part 4/09.90; black



**Item No.: 216-144**

Ferrule; Sleeve for 1.5 mm<sup>2</sup> / AWG 16; un-insulated; electro-tin plated; electrolytic copper; gastight crimped; acc. to DIN 46228, Part 1/08.92; silver-colored



**Item No.: 216-246**

Ferrule; Sleeve for 2.5 mm<sup>2</sup> / AWG 14; insulated; electro-tin plated; electrolytic copper; gastight crimped; acc. to DIN 46228, Part 4/09.90; blue



**Item No.: 216-266**

Ferrule; Sleeve for 2.5 mm<sup>2</sup> / AWG 14; insulated; electro-tin plated; electrolytic copper; gastight crimped; acc. to DIN 46228, Part 4/09.90; blue



**Item No.: 216-286**

Ferrule; Sleeve for 2.5 mm<sup>2</sup> / AWG 14; insulated; electro-tin plated; electrolytic copper; gastight crimped; acc. to DIN 46228, Part 4/09.90; blue



**Item No.: 216-106**

Ferrule; Sleeve for 2.5 mm<sup>2</sup> / AWG 14; un-insulated; electro-tin plated; silver-colored

### 1.2.2 Test and measurement

#### 1.2.2.1 Testing accessories



**Item No.: 210-136**

Test plug; 2 mm Ø; with 500 mm cable; red

### 1.2.3 Tool

#### 1.2.3.1 Operating tool



**Item No.: 210-720**

Operating tool; Blade: 3.5 x 0.5 mm; with a partially insulated shaft; multicoloured



**Item No.: 210-657**

Operating tool; Blade: 3.5 x 0.5 mm; with a partially insulated shaft; short; multicoloured

### Installation Notes

#### Installation

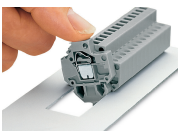

Snapping a feedthrough terminal block (226 Series) into the cutout.

### Testing

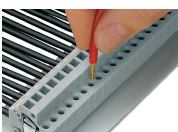

Testing with 2 mm Ø test plug – touch contact.

Subject to changes. Please also observe the further product documentation!

---

Current addresses can be found at: [www.wago.com](http://www.wago.com)