

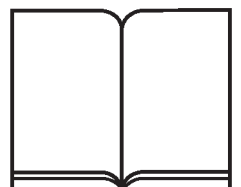

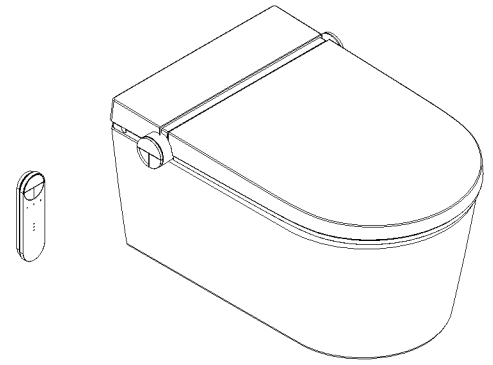

EN	Exhibition mode	2
DE	Ausstellungsmodus	2
FR	Mode d'exposition	2
IT	Modalità esposizione	2
ES	Modo de exhibición / modo exposición	2
NL	Tentoonstellingsmodus	2
DK	Udstillingsmodus	2
BG	Демонстрационен режим	3
CZ	Výstavní režim	3
EL	Λειτουργία επίδειξης	3
HR	Izložbeni način	3
HU	Bemutató üzemmód	3
PL	Tryb demonstracyjny	3
PT	modo de exposição	3
RO	Modul de expoziție	4
SR	Izložbeni režim	4
SV	Utställningsläge	4
SK	Výstavný režim	4
SL	Razstavni način	4







EN

To switch from series to exhibition mode and vice versa, the following procedure is needed. The toilet has to be powered off and on again, and after the initialization and within the following 30 seconds, press and hold  and short press . Repeat the process within 10 seconds.



After the toilet was powered off and on again, the exhibition mode is indicated by the extension of the shower rod after initialization. Complete the process and press . The shower rod will then retract.

DE

Um vom Serien- in den Ausstellungsmodus zu wechseln und umgekehrt, gehen Sie bitte wie folgt vor. Die Toilette muss aus- und wieder eingeschaltet werden. Nach der Initialisierung und innerhalb der folgenden 30 Sekunden drücken und halten Sie  und drücken Sie kurz . Wiederholen Sie den Vorgang innerhalb von 10 Sekunden.



Nachdem die Toilette aus- und wieder eingeschaltet wurde, wird der Ausstellungsmodus durch das Ausfahren des Duschstabs nach der Initialisierung angezeigt. Schließen Sie den Vorgang ab und drücken Sie . Der Duschstab fährt dann wieder ein.

FR

Pour passer du mode série au mode exposition et vice versa, procédez comme suit. Les toilettes doivent être éteintes puis rallumées. Après l'initialisation et dans les 30 secondes suivantes, maintenez la touche  enfoncée et appuyez brièvement sur . Répétez le processus dans les 10 secondes.

Après avoir éteint puis rallumé les toilettes, le mode exposition est indiqué par la sortie de la douchette après l'initialisation. Terminez le processus et appuyez sur . La douchette se rétractera alors.

IT

Per passare dalla modalità serie a quella esposizione e viceversa, seguire la seguente procedura. Il WC deve essere spento e riacceso; dopo l'inizializzazione e entro i successivi 30 secondi, tenere premuto  e premere brevemente . Ripetere il processo entro 10 secondi.



Dopo che il WC è stato spento e riacceso, la modalità esposizione è indicata dall'estensione della bacchetta della doccia dopo l'inizializzazione. Completare il processo e premere . La bacchetta della doccia rientrerà.

ES

Para cambiar del modo serie al modo exhibición y viceversa, siga el siguiente procedimiento. El inodoro debe apagarse y encenderse de nuevo; tras la inicialización y dentro de los siguientes 30 segundos, mantenga pulsado  y pulse brevemente . Repita el proceso en un plazo de 10 segundos.



Después de apagar y encender el inodoro, el modo exhibición se indica mediante la extensión de la barra de la ducha tras la inicialización. Complete el proceso y pulse . La barra de la ducha se retraerá.

NL

Om van de seriemodus naar de tentoonstellingsmodus te schakelen en vice versa, volgt u de volgende procedure. Het toilet moet worden uit- en weer ingeschakeld; na de initialisatie en binnen de volgende 30 seconden houdt u  ingedrukt en drukt u kort op . Herhaal het proces binnen 10 seconden.

Nadat het toilet uit- en weer ingeschakeld is, wordt de tentoonstellingsmodus aangegeven door het uitschuiven van de douchearm na de initialisatie. Rond het proces af en druk op . De douchearm zal dan weer inschuiven.

DK

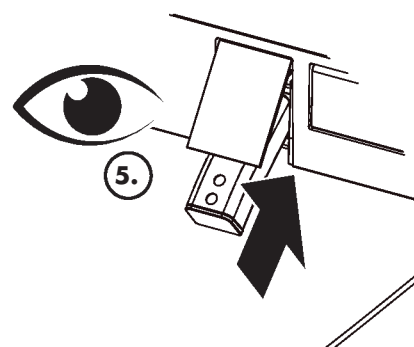
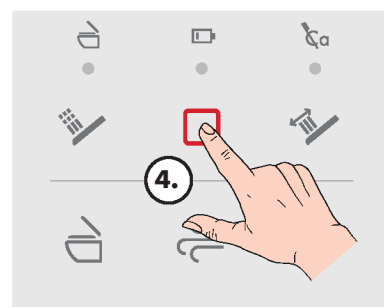
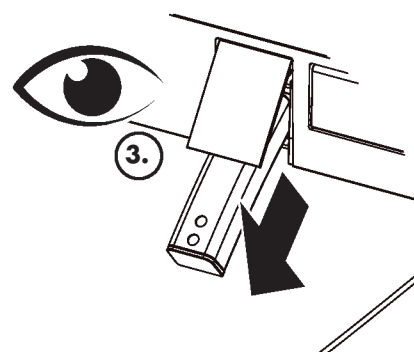
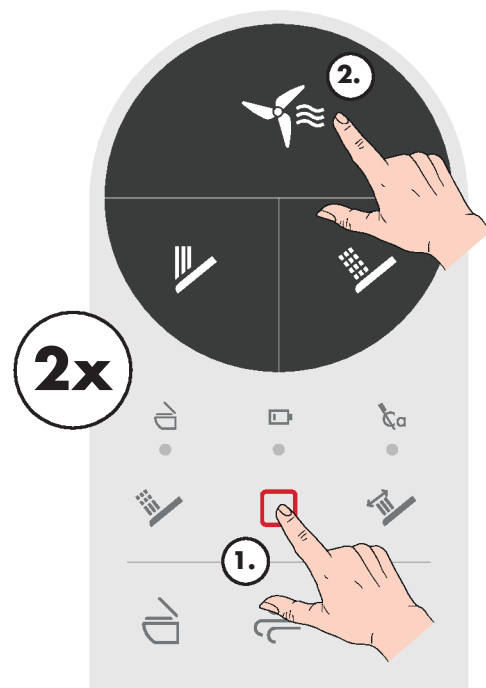

For at skifte fra serie- til udstillingsmode og omvendt, skal følgende procedure følges. Toiletet skal slukkes og tændes igen, og efter initialisering og inden for de næste 30 sekunder skal du holde  nede og kort trykke på . Gentag processen inden for 10 sekunder.

Efter at toiletet er slukket og tændt igen, vises udstillingsmode ved, at bruserstangen kører ud efter initialisering. Afslut processen og tryk på . Bruserstangen trækker sig derefter ind igen.









BG

За да превключите от сериен в демонстрационен режим и обратно, е необходимо следното: Тоалетната трябва да бъде изключена и отново включена. Задръжте  и кратко натиснете . Повторете процедурата в рамките на 10 секунди. Активирането на демонстрационния режим се сигнализира чрез издаване на душ-палката. Завършете процедурата и натиснете . След това душ-палката ще се прибере обратно.



CZ

Chcete-li přepnout ze sériového do výstavního režimu a zpět, postupujte takto: Toaleta musí být vypnuta a znovu zapnuta. Podržte  a krátce stiskněte . Postup zopakujte do 10 sekund. Aktivace výstavního režimu je signalizována vysunutím sprchové tyče. Dokončete postup a stiskněte . Poté se sprchová tyč znovu zasune.



EL

Για να μεταβείτε από τη λειτουργία σειράς στη λειτουργία επίδειξης και αντίστροφα, απαιτείται η ακόλουθη διαδικασία: Η τουαλέτα πρέπει να απενεργοποιηθεί και να ενεργοποιηθεί ξανά. Κρατήστε πατημένο το  και πατήστε σύντομα το . Επαναλάβετε τη διαδικασία μέσα σε 10 δευτερόλεπτα. Η ενεργοποίηση της λειτουργίας επίδειξης υποδηλώνεται από την έξοδο της ράβδου ντους. ολοκληρώστε τη διαδικασία και πατήστε το . Στη συνέχεια, η ράβδος ντους θα εισέλθει ξανά.



HR

Za prelazak iz serijskog u izložbeni način rada i obrnuto potrebno je sljedeće: WC školjka mora biti isključena i ponovno uključena. Držite  i kratko pritisnite . Ponovite postupak unutar 10 sekundi. Aktivacija izložbenog načina signalizira se izvlačenjem tuš-štipača. Dovršite postupak i pritisnite . Zatim će se tuš-štipač ponovno uvući.



HU

A sorozat üzemmódról a bemutató üzemmódra és vissza történő váltáshoz a következő eljárás szükséges: A WC-t ki kell kapcsolni, majd újra bekapcsolni. Tartva lenyomva a -et, és röviden nyomja meg a -t. Ismétlje meg a műveletet 10 másodpercen belül. A bemutató üzemmód aktivlását a zuhanypálca kiemelkedése jelzi. Fejezze be a folyamatot, és nyomja meg a -et. Ezt követően a zuhanypálca ismét visszahúzódik.

PL

Aby przełączyć z trybu seryjnego na tryb demonstracyjny i z powrotem, należy wykonać następujące czynności: Toaleta musi zostać wyłączona i ponownie włączona. Przytrzymaj  i krótko naciśnij . Powtórz czynność w ciągu 10 sekund. Aktywacja trybu demonstracyjnego sygnalizowana jest wysunięciem drążka prysznicowego. Zakończ procedurę i naciśnij . Następnie drążek prysznicowy zostanie ponownie wsunięty.

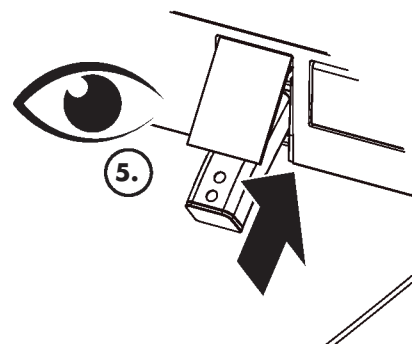
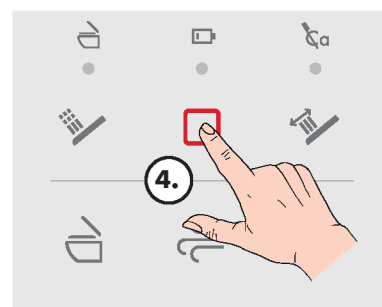
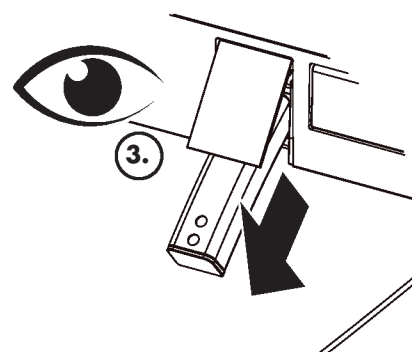
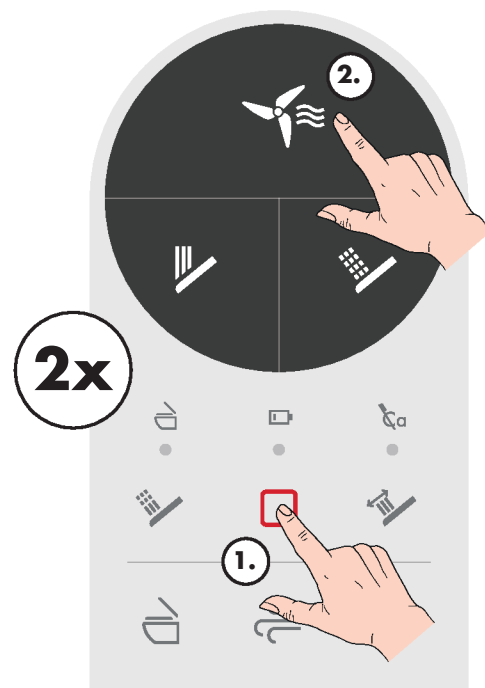

PT

Para alternar do modo de exposição a partir do modo de série e vice-versa, proceda da seguinte forma: A sanita deve ser desligada e ligada novamente. Mantenha pressionado o  e pressione rapidamente o . Repita o procedimento dentro de 10 segundos. A ativação do modo de exposição é sinalizada pela extensão da haste do chuveiro. Para concluir, pressione o . Em seguida, a haste do chuveiro será recolhida novamente.









RO

Pentru a trece din modul de serie în modul de expoziție și invers, este necesar următorul procedeu: Toaleta trebuie oprită și pornită din nou. Țineți apăsat  și apăsați scurt . Repetați procedura în decurs de 10 secunde. Activarea modulului de expoziție este semnalizată prin extinderea barei de duș. Finalizați procedura și apăsați . Bara de duș se va retrage apoi din nou.



SR

Da biste prešli iz serijskog u izložbeni režim i obrnuto, potrebno je sledeće: WC školjka mora biti isključena i ponovo uključena. Držite  i kratko pritisnite . Ponovite postupak u roku od 10 sekundi. Aktivacija izložbenog režima signalizuje se izvlačenjem tuš-štapa. Završite postupak i pritisnite . Zatim će se tuš-štap ponovo uvući.



SV

För att växla från serienläge till utställningsläge och tillbaka krävs följande: Toaletten måste stängas av och slås på igen. Håll ned  och tryck kort på . Upprepa proceduren inom 10 sekunder. Aktiveringen av utställningsläget signaleras genom att duschstaven körs ut. Avsluta processen och tryck på . Därefter dras duschstaven in igen.

SK

Na prepnutie zo sériového do výstavného režimu a späť je potrebný nasledujúci postup: Toaleta musí byť vypnutá a znovu zapnutá. Podržte  a krátko stlačte . Postup zopakujte do 10 sekúnd. Aktivácia výstavného režimu je signalizovaná vysunutím sprchovej tyče. Dokončite postup a stlačte . Následne sa sprchová tyč opäť zasunie.

SL

Za preklon iz serijskega v razstavni način in obratno je potreben naslednji postopek: Stranišče je treba izklopiti in ponovno vklopiti. Držite  in na kratko pritisnite . Postopek ponovite v 10 sekundah. Aktivacija razstavnega načina je signalizirana z iztegom pršne palice. Postopek zaključite in pritisnite . Nato se bo pršna palica ponovno zaprla/vsukala nazaj.

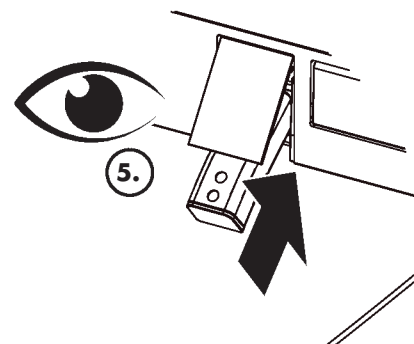
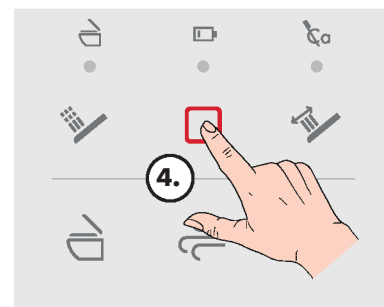
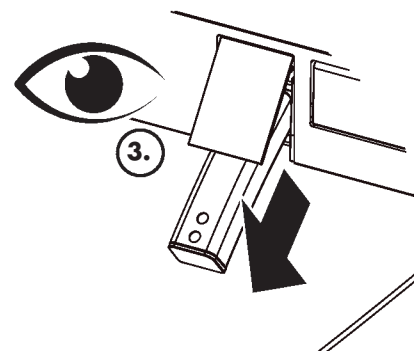
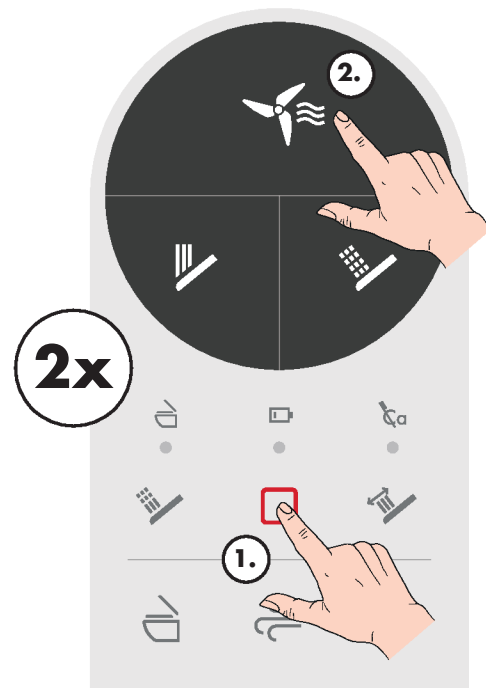

hansgrohe

Hansgrohe · AuestraÙe 5 - 9 · D-77761 Schiltach · Telefon +49 (0) 78 36/51-1282 · Telefax +49 (0) 7836/511440
E-Mail: info@hansgrohe.com · Internet: www.hansgrohe.com