

Color: ■ white

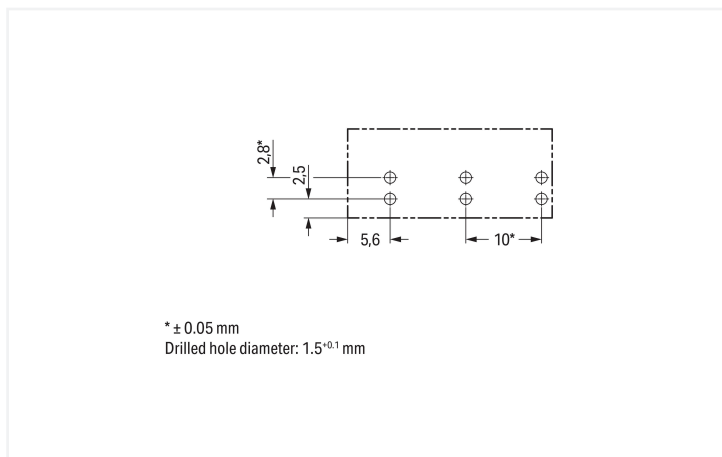

Dimensions in mm

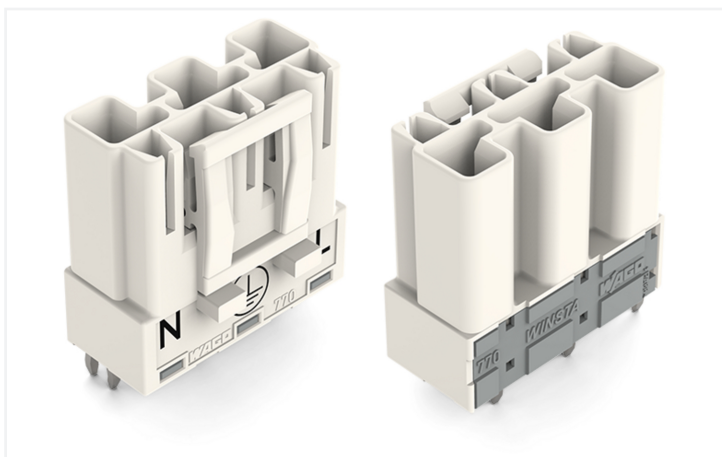
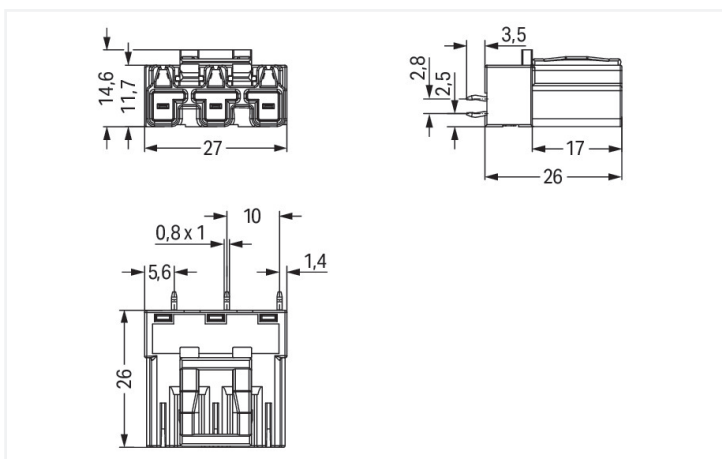

Dimensions in mm

Male connector/plug WINSTA® MIDI rated current 25 A

The WINSTA® MIDI male connector/plug rated current 25 A are compact but outstanding PCB terminal blocks. They offer easy operation and the greatest possible flexibility for installation. Our pluggable PCB connectors provide a universal pluggable connection system for your devices that meets all the requirements for a stable device connection. The mechanical coding and color coding of the pcb connectors ensure error-free installation of the in-

dividual components – including protection against mismatching. Thanks to the color coding and mechanical A coding of WINSTA® MIDI pcb connectors, you can clearly distinguish different circuits. This pcb connectors is used for electrical currents up to 25 A. Thus the product is also suitable for high power loads. WINSTA® MIDI with Push-in CAGE CLAMP® spring pressure connection technology is used in a broad range of individual products you can use for quick, easy, flexible, and secure installation.

Lower costs through fast commissioning and elimination of service expenses – solutions from WINSTA® MIDI

The WINSTA® Pluggable Connection System is perfectly tailored to the very strict requirements of building installation. It makes electrical installation pluggable, and consequently more efficient, more reliable, and error-free. Using this pre-assembled system reduces assembly times and installation errors at the construction site. Now you can also cut installation costs without compromising safety and quality: with marking eliminates the need for servicing and prevents unnecessary downtime.

- protection against mismatching eliminates errors
- for automation controllers
- with A coding for use in many general mains applications
- quick replacement of defective units during ongoing operation

Electrical data

Ratings per	IEC/EN 60664-1			Approvals per	UL 1977
Overvoltage category	III	III	II	Rated voltage	600 V
Pollution degree	3	2	2	Rated current	23 A
Nominal voltage	250 V	-	-		
Rated impulse withstand voltage	4 kV	-	-		
Rated current	25 A	-	-		

General information

Note on contact resistance	approx. 1 mΩ of contact resistance approx. 0.25 mΩ contact transition plug/ socket
----------------------------	--

Connection Data

Total number of potentials	3	Connection 1	
PE function	Preceding PE contact	Pole number	3

Physical data

Pin spacing	10 mm / 0.394 inches
Width	27 mm / 1.063 inches
Height	29.5 mm / 1.161 inches
Height from the surface	26 mm / 1.024 inches
Depth	14.6 mm / 0.575 inches
Solder pin length	3.5 mm
Solder pin dimensions	1 x 0.8 mm
Drilled hole diameter with tolerance	1.5 ^(-0.1 ... +0.1) mm

Mechanical data

Use	General mains applications
Coding	A
Variable coding	Yes
Marking	N ⊕ L
Potential marking	N ⊕ L
Mating force of a plug-in connection	approx. 20 ... 70 N (depending on pole number)
Retention force of a plug-in connection	Locked: > 80 N
Unmating force of a plug-in connection	Unlocked: approx. 20 ... 70 N (depending on pole number)
Number of mating cycles	200, without resistive load
Design	straight

Plug-in connection

Contact type (pluggable connector)	Male connector/plug
Connector (connection type)	for PCB
Mismating protection	Yes
Note on mismating protection	All <i>WINSTA</i> ® components are 100% protected against mismating when: a.) plugging different numbers of poles b.) plugging while rotated 180 c.) plugging while laterally staggered d.) plugging one pole
Mating direction to the PCB	90 °
Locking lever	Yes
Locking of plug-in connection	Locking lever
Note on locking system	All connectors for mounted installations (snap-in versions for lighting fixtures or devices, all types of PCB and distribution connectors) are factory-equipped with locking levers to ensure plugs and sockets are securely locked. Additional locking levers are only required for flying leads (plug/socket).

PCB contact

PCB contact	THT
Solder pin arrangement	2 in-line solder pins/pole
Number of solder pins per potential	2

Material data

Note (material data)	Information on material specifications can be found here
Color	white
Insulation material (main housing)	Polyamide (PA66)
Flammability class per UL94	V0
Clamping spring material	Chrome-nickel spring steel (CrNi)
Contact material	Copper or copper alloy; surface-treated
Contact Plating	Tin
Fire load	0.182 MJ
Weight	6.8 g

Environmental requirements

Processing temperature	-5 ... +40 °C
Continuous operating temperature	-35 ... +85 °C
Note on continuous operating temperature	Insulating parts for temperatures ≤ 105 °C

Commercial data

PU (SPU)	100 pcs
Packaging type	Box
Country of origin	PL
GTIN	4044918511483
Customs tariff number	85366990990

Product Classification

UNSPSC	39121409
eCl@ss 10.0	27-44-06-05
eCl@ss 9.0	27-44-06-05
ETIM 9.0	EC002637
ETIM 10.0	EC002637
ECCN	NO US CLASSIFICATION

Environmental Product Compliance

RoHS Compliance Status	Compliant, No Exemption
------------------------	-------------------------

Approvals / Certificates

General approvals



Approval	Standard	Certificate Name
CCA DEKRA Certification B.V.	EN 61535	71-123228
CCA DEKRA Certification B.V.	IEC 61535	NL -84761
cURus Underwriters Laboratories Inc.	UL 1977	E45171
cURus Underwriters Laboratories Inc.	UL 1059	E 45172

Declarations of conformity and manufacturer's declarations

Approval	Standard	Certificate Name
EU-Declaration of Confor- mity WAGO GmbH & Co. KG	-	-

Approvals for marine applications



Approval	Standard	Certificate Name
ABS American Bureau of Ship- ping	-	24-0095977-PDA
DNV GL Det Norske Veritas, Ger- manischer Lloyd	-	TAE00001Z6
LR Lloyds Register	IEC 61984	LR22429487TA

Downloads

Environmental Product Compliance

Compliance Search

Environmental Product Compliance 770-833



CAD/CAE-Data

CAD data

2D/3D Models 770-833



CAE data

EPLAN Data Portal 770-833



ZUKEN Portal 770-833



1 Compatible Products

1.1 System counterpart

1.1.1 Cable assembly



Item No.: 771-9993/106-102

pre-assembled connecting cable; Eca; Socket/open-ended; 3-pole; Cod. A; H05VV-F 3G 1.5 mm²; 1 m; 1,50 mm²; white

Item No.: 771-9993/006-102

pre-assembled interconnecting cable; Eca; Socket/plug; 3-pole; Cod. A; H05VV-F 3G 1.5 mm²; 1 m; 1,50 mm²; white

1.1.2 Female connector/socket



Item No.: 770-223

Socket; 3-pole; Cod. A; white

Item No.: 770-123

Socket; with strain relief housing; 3-pole; Cod. A; 4,00 mm²; white

Item No.: 770-223/035-050

Socket; with strain relief housing; 3-pole; Cod. A; 4,00 mm²; white

1.2 Required Accessories

1.2.1 Cover

1.2.1.1 Cover



Item No.: 770-360

Lockout cap; for plugs; 5-pole; separable; yellow

1.3 Optional Accessories

1.3.1 Coding

1.3.1.1 Coding



Item No.: [770-401](#)

Coding pin; for plugs; Plastic; gray