



# flamco

## ENA 7-30



that's excellence.



**ENG** Installation and operating manual

# Table of contents

<b>1. General.....</b>	<b>4</b>
1.1. About this manual.....	4
1.2. Other supplied documentation .....	4
1.3. Use of Flamco products.....	4
1.4. Further help and information.....	4
<b>2. Safety .....</b>	<b>5</b>
2.1. Intended use .....	5
2.2. Important information .....	5
2.3. Signs in this manual.....	5
2.4. Specifications.....	6
2.5. Safety devices.....	6
2.6. Signs on the automat.....	7
<b>3. Description .....</b>	<b>8</b>
3.1. Component overview.....	8
3.2. Controller SCU.....	9
3.3. Working principle .....	9
<b>4. Transport and storage.....</b>	<b>11</b>
4.1. Transport.....	11
4.2. Storage .....	11
<b>5. Installation .....</b>	<b>12</b>
5.1. Prepare for installation .....	12
5.2. Ambient conditions .....	12
5.3. Hydraulic installation.....	13
5.4. Electrical installation .....	13
5.5. Basic electrical connection.....	14
<b>6. Startup controller .....</b>	<b>17</b>
6.1. Controller menu structure.....	17
6.2. Menu symbols .....	17
6.3. Working principle controller .....	18
6.4. Controller inputs .....	19

<b>7. Maintenance and troubleshooting .....</b>	<b>20</b>
7.1. Before maintenance.....	20
7.2. After a power failure.....	20
7.3. Maintenance interval .....	20
7.4. Change the automat for water treatment.....	20
7.5. Error message.....	21
<b>8. Disposal .....</b>	<b>24</b>
<b>9. Technical specification.....</b>	<b>25</b>
9.1. Additional accessories.....	26
<b>10. Appendix 1. Commissioning.....</b>	<b>27</b>
10.1. Commissioning ENA 7-30 .....	27
10.2. Parameterisation for commissioning .....	27
<b>11. Appendix 2. Items of the hardware and parameter menu .....</b>	<b>28</b>
11.1. Operating modes .....	28
11.2. Control modes.....	29
11.3. Monitoring .....	29
<b>12. Appendix 3. Menu descriptions.....</b>	<b>31</b>
12.1. Hardware menu .....	31
12.2. Parameter menu.....	32
12.3. Service menu.....	34
<b>13. Appendix 4. Examples .....</b>	<b>35</b>
13.1. ENA 7-30 with NFE1.1 and a diaphragm expansion vessel in a heating system.....	35
13.2. ENA 7-30 with NFE1.2 and a compressor controlled pressure level in a heating system .....	36

# 1. General

## 1.1. About this manual

This manual includes technical specifications, instructions and explanations that helps to use this automat safely. Read and understand all the instructions before you transport, install, commission, restart, operate or maintain the automat.

## 1.2. Other supplied documentation

General information of additional components, such as the pump and the sensors, is included in this manual. If additional documentation is supplied, also follow the instructions in those.

## 1.3. Use of Flamco products

According to order or execution complementary documentations can be added. Follow the positions performed in the dispatch papers.

## 1.4. Further help and information

Contact your local supplier for additional services as:

- Training.
- Maintenance agreements
- Service contracts.
- Repairs and improvements.

## 2. Safety

### 2.1. Intended use

The automat is designed for deaerating and feeding make-up water in closed heating and in cooling water systems.

The automat is not designed for the initial filling or re-filling of systems.

### 2.2. Important information

The automat has safety devices intended to prevent injury and damage. Use the automat in the following way:

Have the installation be carried out by qualified personnel.

- Comply with local legislation and guidelines.
- Do not make modifications to the automat without prior written permission of Flamco.
- Make sure that all automat covers and doors are closed when operating the automat.
- Do not touch live voltage. The sensor units and the capacity pressure sensors operate with extra low safety voltage.

Flamco shall not be liable for any losses arising from the non-observance of safety conditions or as a consequence of the disregard of standard precautionary measures when performing such services as transport, installation, commissioning, re-starting, operation, maintenance, testing and repair, even in the event that these are not expressly described in these instructions.

### 2.3. Signs in this manual



Identifies a hazard that could lead to personal injury including death/damage to the automat, damage to other equipment and/or environmental pollution.



Identifies an electric hazard that could lead to personal injury including death/ damage to the automat, damage to other equipment and/or environmental pollution.



Earthing



Important information

## 2.4. Specifications

The construction of the automat is designed in accordance with the norms DIN EN 12828.

## 2.5. Safety devices

The automat does not contain any safety components that prevent that the operation pressure and the operation temperature range are exceeded or go below a limit. Install components for the limitation of pressure and temperature in the system

### 2.5.1. Avoiding excessive pressure

Appropriate safety valves that prevent that the maximum operation pressure is exceeded:

- Open not later than the maximum allowable working pressure is reached.
- Can conduct the occurring volume flow (including the maximum possible refilling volume) up to the 1.1-fold of the maximum operation pressure;
- Have a proven reliability or are certified.



Do not narrow the inlet or outlet piping of the safety valve.

### 2.5.2. Avoiding excessive temperature

Appropriate safety components:

- Guarantee that the operation temperature range is not exceeded at any point of the system;
- Are approved and tested on operation safety.



Activate the pressure and temperature safety devices and check them regular on proper working.

## 2.6. Signs on the automat

The signs on the automat are part of the safety provisions. Do not cover or remove the signs. Inspect regularly if the signs are present and legible. Replace or repair signs that are illegible or damaged.

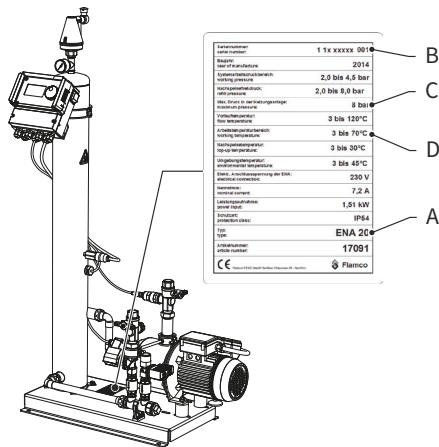

On the type plate the following product information can be found:

- A: Automat type (ENA 10, 20 or 30)
- B: Automat serial number
- C: Permissible working overpressure
- D: Permissible working temperature



Do not use the automat when the specifications on the type plate differ from the order.

## 3. Description

### 3.1. Component overview

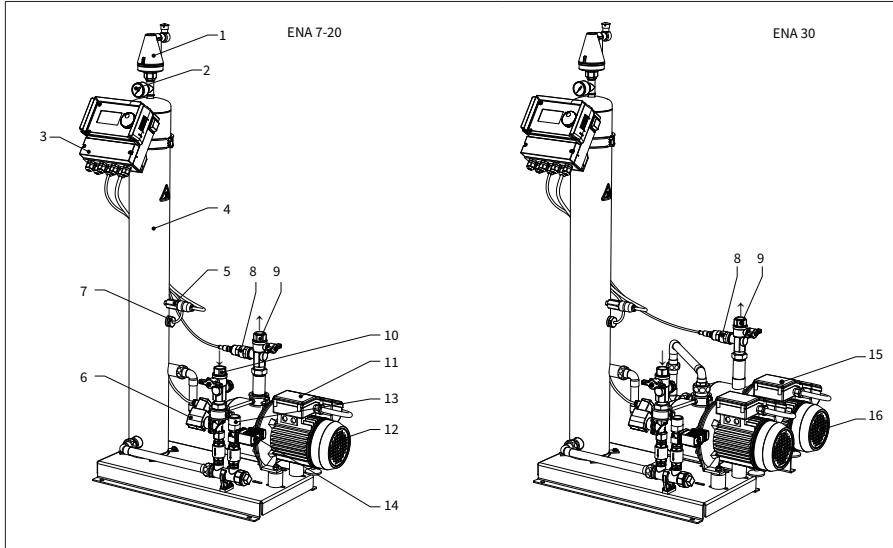

NO.	Description		Description
1	Vent. device	9	Connection to system Rp 1"
2	Pressure gauge	10	Connection from system Rp 3/4" *
3	SCU controller	11	Terminal box pump 1
4	Vacuum tank	12	Pump 1
5	Vacuum pressure switch	13	Connection for refill Rp 3/4"
6	Solenoid valve N.O.	14	Solenoid valve N.C.
7	Float switch	15	Terminal box pump 2
8	Pressure sensor	16	Pump 2

### 3.2. Controller SCU

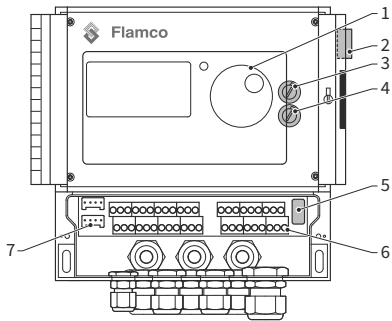

NO.	Description
1	Control panel for the controller, graphical display, LED for error display, selector switch (click and roll)
2	Power switch, ON: flashes red
3	Internal fuse F1: T 16 A 250 V
4	Internal fuse F2: T 3,5 A 250 V
5	Hardware release, service menu E2
6	Terminal bars for <ul style="list-style-type: none"> <li>• Electric supply;</li> <li>• Sensors;</li> <li>• Impulse water counter;</li> <li>• External activation for refilling process;</li> <li>• Collective malfunction message;</li> <li>• Pump.</li> </ul>
7	Interface RS485.

### 3.3. Working principle

The automat serves primarily as an active deaerating device. In addition as a make-up device for re-filling the water losses in a system.

#### 3.3.1. Deaeration

For deaerating the water, the system water is drawn in via a bypass from the return line

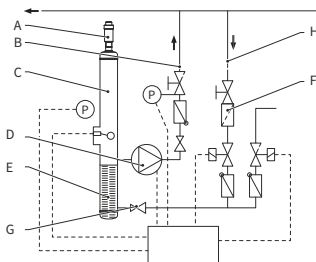

of the system (H). The water is run through a flow regulator (G) and the strainer (F) into the deaeration tank (C). It is subjected to a vacuum during the cyclic running of the pump (D) and passed through a Pall-ring (E). As a result of the lowered pressure, and the large surface of the Pall-ring, air dissolves from the water.

When the pump switches off, the replenishing medium flowing into the tank causes the pressure in the tank to increase to the level of the system pressure so that the air which has accumulated above the water level is discharged via the vent. device (**A**). While the pump is running, the water quantity supplied into the tank is returned via a bypass line to the return branch (**B**) of the system.

- Fast deaeration mode (Fast = Turbo): An interval during which the pump is running (vacuum is forming) alternates with an interval during which the air is discharged (pump is stopped).
- Normal deaeration mode: An additional pause is added between the end of the evacuation interval and the starting of the pump. This additional interval can be selected via a parameter within fixed limits. Upon expiry of the deaeration interval, the system changes to the normal deaeration mode, which then takes place continuously. The normal deaeration mode is interrupted by a selectable pause (by default 06.00 p.m. - 08.00 a.m.). The beginning of the next deaeration cycle taking place in the normal deaeration mode is indicated via a countdown in the Process menu.

### 3.3.2. Make-up operation

The make-up water is supplied in a pressure-controlled or level-controlled mode. The automat is set by default to pressure-controlled refilling (if a diaphragm expansion vessel is used).

- Pressure-controlled supply: The system is equipped with a pressure sensor (P) for sensing the pressure. The make-up activating pressure should be  $P_o^* + 0.2$  bar. The make-up deactivating pressure must be at least 0.1 bar higher than the make-up activating pressure. The make-up water flow rate or feed time can be monitored, if the system is fitted with a litres counter. The pump (D) must be automatically stopped cyclically during pressure-controlled refilling, and the actual system pressure must be checked and, if necessary, additional water must be supplied until the make-up deactivating pressure is reached.

- Level-controlled supply: In this case, make-up water is supplied as long as the external make-up request is active and the flow-rate and time monitoring feature of the automat allows making up to take place.

It is possible to deactivate the make-up function. Refer to chapter 6.1.

\*  $P_o = P_{Static} + P_{Steam}$

## 4. Transport and storage

### 4.1. Transport

The shipping papers list all the items, such as equipment and documentation. Ensure that the delivery is complete and not damaged. The automats are packed horizontally on disposable pallets and are fully assembled.



Identify the items that are missing or not correctly delivered. Read the general terms and conditions in the shipping papers.

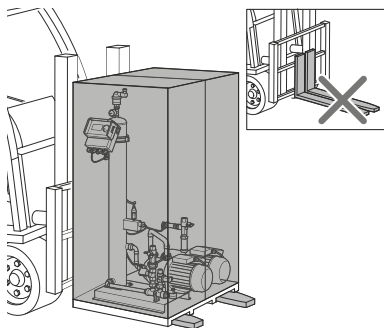

- Transport the pallets horizontally.
- Lift the automat just slightly.



Identify the items that are missing or not correctly delivered. Read the general terms and conditions in the shipping papers.

### 4.2. Storage

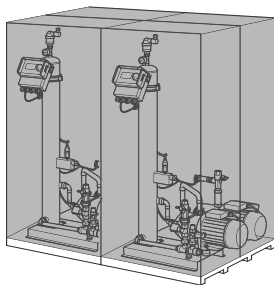

Make sure that the storage space meets the ambient conditions. Refer to section 6.2.

- Take care for an even floor.



Do not stack up.

## 5. Installation

### 5.1. Prepare for installation



Make sure that the surface can support the maximum weight of the automat, including the water.

Refer to chapter 9: Technical specifications

- The automat may not be affected by external forces.
- No dirt may get into the automat and its accessories.
- Install shut-off devices to the drinking water net on-site.
- Plan enough free space around the automat for maintenance work.
- Note the effective regulations regarding the use and the installation location and, if necessary, inform the responsible testing and certification bodies prior to the launch of the system

### 5.2. Ambient conditions

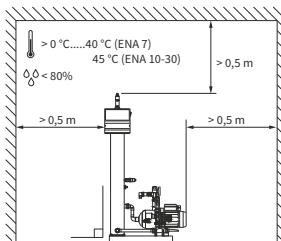

Make sure

- that the automat is level;
- that the automat is installed in a closed, dry and frost-free room;
- to maintain the minimum distances as indicated;
- that the atmosphere does not contain electrically conducting gases or high concentrations of dust and vapors. Risk of explosion when there are combustible gases;
- that the vicinity is clean and well lit.
  - Relative humidity: not condensating.
  - Free of vibrations.
  - Free from heat- and solar radiation.
- that the automat is free from additional loads

### 5.3. Hydraulic installation



- Install the shut-off devices on-site in front of the tube joints.
- Only work on non-pressurised and cooled-down pressure joints.

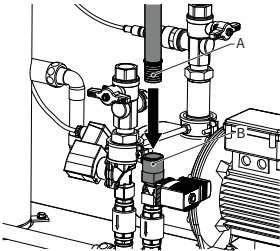

• Connect the supply line to the refilling supply. If necessary, install a dirt trap at the drinking water joint (0.2 mm).

• The minimum nominal diameter for the installation line of the system and the supply line is DN 20

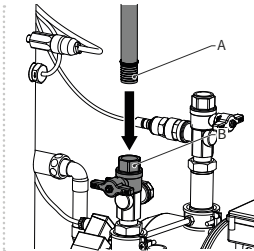

• Connect the return line of the system to the inlet of the ENA.

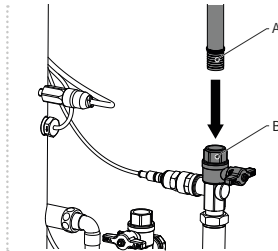

• Connect the supply line of the system to the pressure side of the ENA

### 5.4. Electrical installation



There can be life voltage on the terminal bars even when the main power supply is disconnected.

Make sure all external power supplies (e.g. external refill equipment) are also disconnected from the automat.

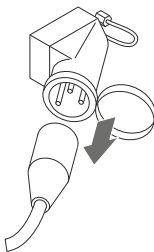

Switch off the power switch on the controller SCU.

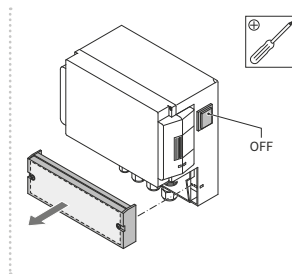

Unscrew the protective cover of the terminal box.

Pull the power plug or switch off external separators and secure these against a restart.

The descriptions of the terminal bars are on the inside of the protective cover.

## 5.5. Basic electrical connection

	ENA 7	ENA 10		
Nominal voltage	230 V: +6%; -10%; 50 Hz: +1%; -1%			
Nominal current	2.77 A	5.3 A	7.2 A	10.6 A
Nominal power	0.62 kW	1.1 kW	1.51 kW	2.2 kW
Safety current	10 A	16 A		
Protection type	IP55	IP54 (pressure sensor IP65)		

SELV: Safety Extra Low Voltage

\* Recommended value; Line safety switch (C).



Never connect terminal 11+12 and 21+22 at the same time. It will destruct the refill the SCU controller or the pressure holding control.

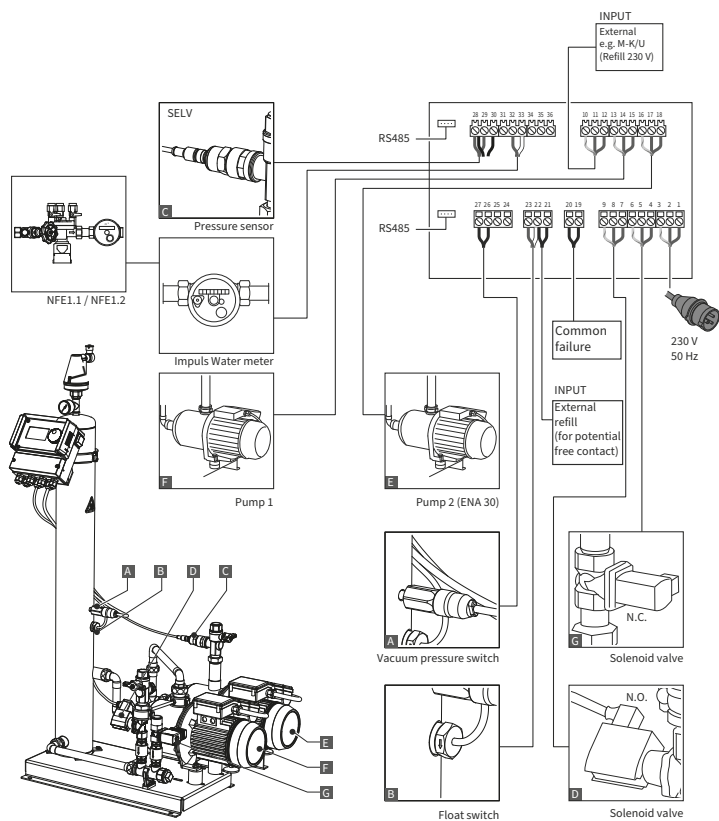

	9	8	7	6	5	4	3	2	1
<b>Solenoid valve N.O.</b>	yellow/ green	blue	brown						
<b>Solenoid valve N.C.</b>				yellow/ green	blue	brown			
<b>Mains</b>							yellow/ green	blue	brown

	10	11	12	13	14	15	16	17	18
<b>External refill</b>	yellow/ green	blue	brown						
<b>Pump 1</b>				yellow/ green	blue	brown			
<b>Pump 2</b>							yellow/ green	blue	brown

	27	26	25	24	23	22	21	20	19
<b>Vacuum pressure switch</b>	brown	blue							
<b>Float switch</b>					brown	white			
<b>External refill</b>						gray	gray		
<b>Common faillure</b>								gray	gray

	28	29	30	31	32	33	34	35	36
<b>Solenoid valve N.O.</b>	brown		yellow						
<b>Solenoid valve N.C.</b>	brown	blue							
<b>Mains</b>					red	white			

# 6. Startup controller

## 6.1. Controller menu structure

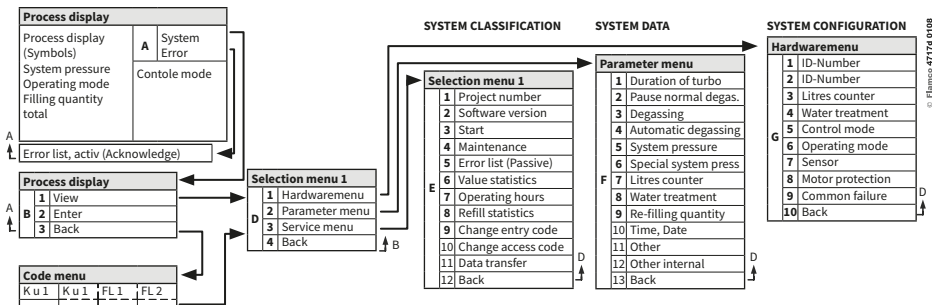

## 6.2. Menu symbols

	No ID number available. Controller not configured.		Pump
	Denied, not installed. Outside parameter limits.		Float switch.
	Refill is pressure controlled		Entry confirmed.
	Code required		Programming mode, enter.
	Refill is level controled.		Test mode.
	Solenoid valve.		Warning.
	No intervention possible		Save error. Settings not saved.
	Operating mode, view only.		Wait.
	Vacuum switch.		External refill signal is connected (level controled operation only).

## 6.3. Working principle controller

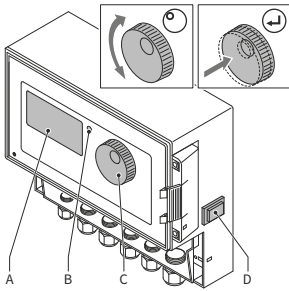

### Start up

- Switch off an installed refill equipment.  
Close the inflow valves.
- Switch on the controller (D).

### A Display

B Error LED

C Navigation wheel

D ON/OFF switch controller

Use the navigation wheel (C) to navigate through the menus and to confirm the input. The display (A) shows the menus. In case of errors the error LED (B) is on.

- Hold down the navigation wheel for two seconds to go to the process display, whatever the cursor position.

\* Turbo = Fast

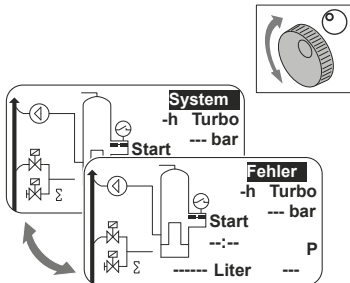
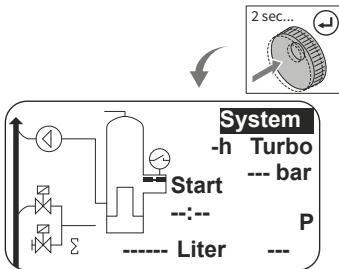

- In case of errors the process display switches from [SYSTEM] to [ERROR] and the LED is on.
- The error messages, minimum water level, minimum pressure alarm are consistent by the first start of operation.
- It is possible to turn the wheel to switch between [SYSTEM] and [ERROR].
- When [ERROR] is displayed press the wheel to go to the error list. In case of more than one error, scroll through the errors. All errors are shown in accordance of appearance.
- When [SYSTEM] is displayed, press the wheel to go to the option menu.

\* Turbo = Fast

## 6.4. Controller inputs

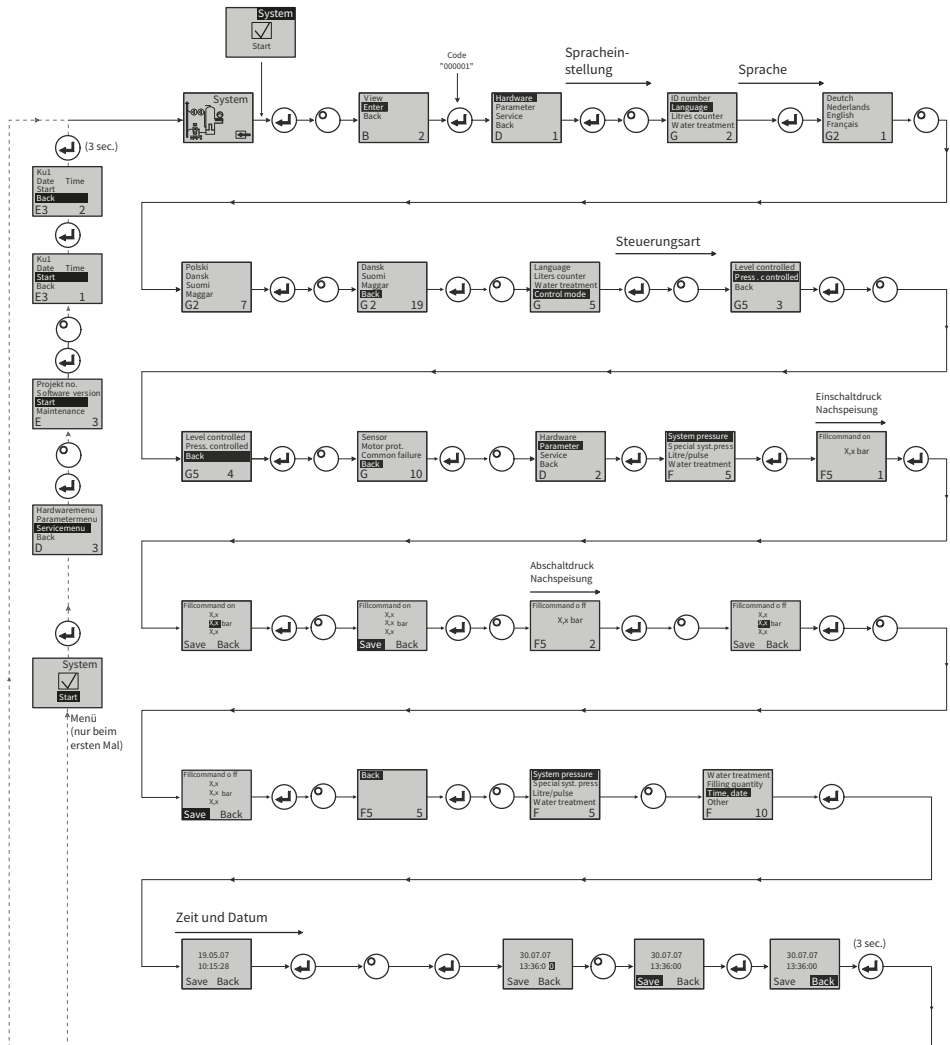

- When entering the program mode, the control for pressure maintenance is active.
- The code will be active 5 minutes after latest input.
- Remove all unpermitted loads, supported objects or lateral loads from the basic automat.
- When the programming procedure is completed, the electrical parts of the ENA are ready for operation.

## 7. Maintenance and troubleshooting



- The water and the contact surfaces can be 70 °C or more.
- Wear the required protective clothing.
- The floor can be wet or greasy. Wear protective shoes.

### 7.1. Before maintenance

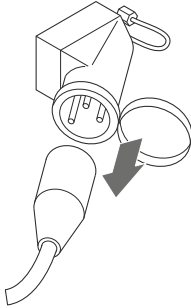

There can be life voltage on the terminal bars even when the main power supply is disconnected.

Make sure all external power supplies (e.g. external refill equipment) are also disconnected from the automat.

Release the pressure of vacuum tank before maintenance.

### 7.2. After a power failure

The programmed parameters of the controller do not change after a power failure.

Check the condition of the automat for integrity after a power failure.



### 7.3. Maintenance interval

Confirm maintenance in the service menu.

Interval	Component	Activity
Annually	ENA 7-30	Check leak tightness of joints, pumps and screw connections. If necessary, seal or tighten the screw connections.
Every year before the peak period	On-site dirt trap in the feed line Vent. device	Clean the guards Check the functions Vacuum test

### 7.4. Change the automat for water treatment

- Switch off water treatment in the hardware menu and change the module.
- Adjust the capacity in the parameter menu.

- Switch on “water treatment” in the hardware menu

## 7.5. Error message

NR	Message	Description	Reset	Possible cause	Troubleshooting
1	Pressure too low	System pressure too low, is outside working pressure range	B	<ul style="list-style-type: none"> <li>• Leakage</li> <li>• Pressure-holding value wrongly set</li> <li>• Wrong admission pressure</li> <li>• Filling pressure too low</li> </ul>	<ul style="list-style-type: none"> <li>• Eliminate leakage</li> <li>• Set correct pressure-holding value</li> <li>• Increase filling pressure up to working pressure range</li> </ul>
2	Pressure too high	System pressure too high, is outside working pressure range	B	<ul style="list-style-type: none"> <li>• Pump does not switch off</li> <li>• Diaphragm expansion vessel too small/ wrong admission pressure</li> <li>• Filling pressure too high</li> </ul>	<ul style="list-style-type: none"> <li>• Check control</li> <li>• Check admission pressure / use larger diaphragm expansion vessel</li> <li>• Lower filling pressure to working pressure range</li> </ul>
3	Entrycap. too low	Litres counter does not supply water after make-up request	A	<ul style="list-style-type: none"> <li>• No pulses sent from litres counter, because:</li> <li>• litres counter defective</li> <li>• cable not connected</li> </ul>	<ul style="list-style-type: none"> <li>• Replace litres counter</li> <li>• Connect cable</li> <li>• Use higher setting value for response time</li> </ul>
5	Cycle interval	Make-up cycle interval too short	A	<ul style="list-style-type: none"> <li>• Leakage in system</li> <li>• False setting value</li> </ul>	<ul style="list-style-type: none"> <li>• Eliminate leakage</li> </ul>
6	Nr. of cycles	Maximum number of cycles within time window exceeded	A	<ul style="list-style-type: none"> <li>• Leakage in system</li> <li>• False setting value</li> </ul>	<ul style="list-style-type: none"> <li>• Eliminate leakage</li> <li>• Program correct settings</li> </ul>
7	Fill error	Filling without request (litres counter sends signal without filling)	A	<ul style="list-style-type: none"> <li>• Leakage</li> <li>• Solenoid valve don't close/defective</li> </ul>	<ul style="list-style-type: none"> <li>• Eliminate leakage</li> <li>• Replace solenoid valve</li> </ul>
8	Quantity limit	Maximum quantity in a make-up cycle exceeded	A	<ul style="list-style-type: none"> <li>• Leakage</li> <li>• Setting value for flow rate reduction too low</li> </ul>	<ul style="list-style-type: none"> <li>• Eliminate leakage</li> <li>• Correct the setting value</li> </ul>
9	Runtime protection	Maximum time in a make-up cycle exceeded	A	<ul style="list-style-type: none"> <li>• Leakage</li> <li>• Setting value for flow</li> <li>• Pump doesn't deliver</li> </ul>	<ul style="list-style-type: none"> <li>• Eliminate leakage</li> <li>• Correct the setting value</li> <li>• Deaerate pump</li> </ul>
10	Exchange module	Softening module exhausted	A	<ul style="list-style-type: none"> <li>• Module capacity (water treatment) exhausted</li> </ul>	<ul style="list-style-type: none"> <li>• Replace module</li> </ul>

11	Low mA P-sensor	Interruption of current loop of pressure sensor	A	<ul style="list-style-type: none"> <li>• Sensor defective</li> <li>• Terminal/cable defective</li> </ul>	<ul style="list-style-type: none"> <li>• Replace sensor</li> <li>• Check/exchange terminal/ cabling</li> </ul>
12	High mA P-sensor	Short-circuit in current loop of pressure sensor	A	<ul style="list-style-type: none"> <li>• Sensor defective</li> <li>• Terminal/cable defective</li> <li>• Short circuit</li> </ul>	<ul style="list-style-type: none"> <li>• Replace sensor</li> <li>• Check/exchange terminal/ cabling</li> </ul>
13	Vacuum error	3 times in succession insufficient vacuum for deaeration	A	<ul style="list-style-type: none"> <li>• Temperature in return branch higher than 70 °C</li> <li>• Pump does not operate continuously</li> <li>• Leakage in ENA 7-30</li> <li>• Vent device doesn't close</li> </ul>	<ul style="list-style-type: none"> <li>• Take steps for ensuring return temperatures below 70°C!</li> <li>• Replace pump</li> <li>• Locate leakage in ENA 7-30</li> <li>• Clean or replace vent. device</li> </ul>
14	Level switch error	Low level	A	<ul style="list-style-type: none"> <li>• Vent. device defective</li> <li>• Strainer / inlet protected</li> <li>• Valves closed</li> </ul>	<ul style="list-style-type: none"> <li>• Clean or replace vent. device</li> <li>• Clean strainer</li> <li>• Open valves</li> </ul>
18	Next maintenance	Next maintenance due	A	<ul style="list-style-type: none"> <li>• Maintenance date reached</li> </ul>	<ul style="list-style-type: none"> <li>• Carry out maintenance and enter „Maintenance done“ (Service menu)</li> </ul>
19	TP motor	Motor protection signal (bimetal contact of pump) is active (open)	A	<ul style="list-style-type: none"> <li>• Pump overheated</li> </ul>	<ul style="list-style-type: none"> <li>• Check temperatures</li> <li>• Check free running pump</li> </ul>
20	Voltage sensor	Sensor voltage too low	B	<ul style="list-style-type: none"> <li>• Printed circuit board defective</li> </ul>	<ul style="list-style-type: none"> <li>• Replace control unit</li> </ul>
21	No date/time	RTC has no valid time information	A	<ul style="list-style-type: none"> <li>• Time setting has got lost after prolonged disconnection from power supply</li> </ul>	<ul style="list-style-type: none"> <li>• Enter time and date again</li> </ul>
22	Flash error	Read error Flash	B	<ul style="list-style-type: none"> <li>• Hardware/ software problem</li> </ul>	<ul style="list-style-type: none"> <li>• Get in contact with service department</li> </ul>
23	Flash error	Write error Flash	B	<ul style="list-style-type: none"> <li>• Hardware/ software problem</li> </ul>	<ul style="list-style-type: none"> <li>• Get in contact with service department</li> </ul>
24	Flash error	Reprogramming error Flash	B	<ul style="list-style-type: none"> <li>• Hardware/ software problem</li> </ul>	<ul style="list-style-type: none"> <li>• Get in contact with service department</li> </ul>
25	Gas sensor defective	Gas sensor defective	A	<ul style="list-style-type: none"> <li>• Malfunctions in measuring signal, possible faulty cable connection to SCU</li> </ul>	<ul style="list-style-type: none"> <li>• Check connection to controller, Exchange sensor if necessary</li> </ul>
26	Gas sensor, undervoltage	Signal during Measurement <4mA	A	<ul style="list-style-type: none"> <li>• Sensor not connected, cable damage</li> </ul>	

27	Gas sensor, overvoltage	Signal during Measurement >20mA	A	<ul style="list-style-type: none"> <li>• Short-circuit in cable, signal too large</li> </ul>	<ul style="list-style-type: none"> <li>• Test cable connections, test vent device, if necessary clean the filters</li> </ul>
28	Recurring indication of gas value "0"	several successive small gas values during measurement	A	<ul style="list-style-type: none"> <li>• Vent blocked/not working correctly</li> </ul>	<ul style="list-style-type: none"> <li>• Check and clean vent device</li> </ul>

A: Necessary, reset possible within normal use (control restarts after resetting).

B: No duty, automatic reset within normal use.

## 8. Disposal



Comply with local legislations.

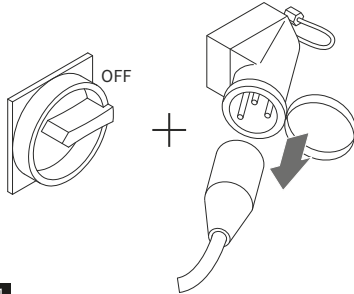

1



- Make sure the system power switch is OFF.
- Disconnect the power supply.

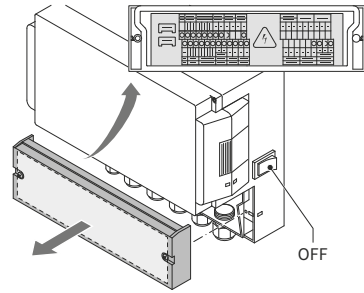

2

- Make sure the main power switch is OFF.
- Drain the water.

# 9. Technical specification

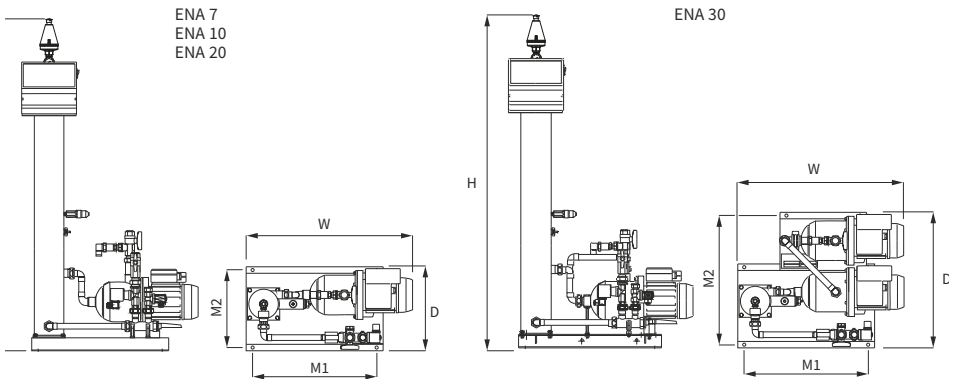

General		ENA 7	ENA 10	ENA 20	ENA 30
Article number	[-]	17070	17090	17091	17092
Volume	[l]	60	80	100	100
Working pressure	[bar]	0.8-2.7	0.8-3.5	2.0-4.5	3.0-8.0
Refill pressure	[bar]	2-8			
max. pressure	[bar]	8	8	8	10
Medium temperature	[°C]	>0-70			
Top-up temperature	[°C]	>0-30			
Noise level	[dB(A)]	approx. 55			
Electrical connection	[V]	230	230	230	230
Rating of the pump(s)	[kW]	1 x 0.62	1 x 1.1	1 x 1.51	2 x 1.1
Connections, dimensions, weights					
W x H x D	[mm]	728 x 1250 x 325	728 x 1250 x 325	776 x 1250 x 325	728 x 1250 x 525
Connection from system		Rp 3/4" (internal)			
Connection to system		Rp 1" (internal)			
Top-up connection		Rp 3/4" (internal)			
Weight	[kg]	38	40	45	60
Glycol	%	30			

Nominal diameter	Maximum line length system installation
DN 20	10 m
DN 25	20 m
DN 32	30 m

## 9.1. Additional accessories

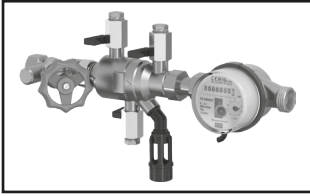

### **Pressurisation Unit type NFE 1...(3)**

Feeds the machine with water. Make sure the water pressure is 2 to 8 bar.

The level sensor and the make-up time control the unit.

## 10. Appendix 1. Commissioning

### 10.1. Commissioning ENA 7-30

Before commissioning make sure that the unit and its items of equipment are in conformation with the regulations that apply at the place of erection and in respect of the field of application. The party erection and operating the unit will be responsible for making the checks and for carrying out commissioning.

For commissioning, the hydraulic and electric connections must be in place, and the shut-off devices open.

### 10.2. Parameterisation for commissioning

The ENA 7-30 comes with a pre-parameterized control. As this control offers a wide range of possibilities, you will have to set operating parameters so that they will be adapted to the concrete operating conditions of your heating/cooling system.

When the control is switched on, first 'ENA 7-30' and after that the start screen appears on the display. Now it is possible to make a selection by turning and pressing the control knob.

Turn and press the control knob (on System, displayed against a black background) to get to the Selection menu. Select 'Entries' (code 000001) to get to the Equipment, Parameter and Service menus for carrying out parameterization. Set up the control point by point – refer to the sections with explanations on the Hardware, Parameter and Service menu (ENA 7-30 – Installation and operating instructions).

Select 'Back' to return to or to complete menu items. For completely exiting submenus, you can also hold the control knob in the pressed state, causing the control to invoke the Process screen/START menu.

On completing the parameterization of the control, confirm/press Start to get to the Process screen.

The ENA 7, 10, 20, or 30 will then commence its operation

# 11. Appendix 2. Items of the hardware and parameter menu

## 11.1. Operating modes

The operator can operate the system in the fast and normal de-aeration mode. Service personnel have also access to hand mode, and can carry out a leakage test. This leakage (vacuum) test can also be used to test the ability to operate the pump.

### 11.1.1. Fast/Turbo

Pump running (with formation of a vacuum) takes place alternately with the evacuation interval until the period of time selected for the fast mode expires. Then, the control automatically changes to normal mode.

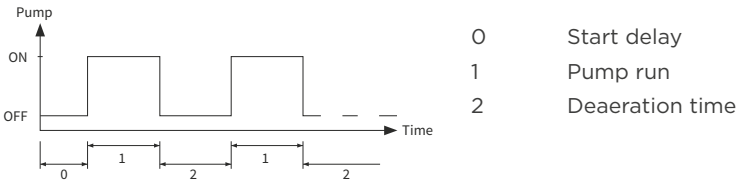

### 11.1.2. Normal

The normal de-aeration mode is only automatically interrupted by a pause to avoid possible de-aeration noise during the night.

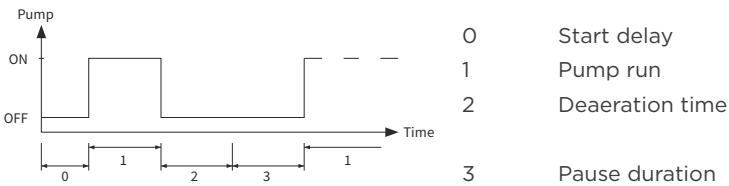

### 11.1.3. Hand

The hand mode is intended exclusively for maintenance purposes, i.e. for checking the operation of the pump and of the solenoid valve. The plant operator cannot access this mode.

- Vacuum test

Activation of this mode first causes the system port (at outlet of the system return line) to be closed. The pump then generates a vacuum within 5 seconds. This vacuum must be maintained for about 100 seconds to allow the user to determine that the tank is

tight, following which the test is successfully completed. This test is normally carried out prior to commissioning of the system and after maintenance of the system.

## 11.2. Control modes

### 11.2.1. Level-controlled [%]

Control takes place via an external floating signal or a non-floating signal (230 V). It depends on the used pressureholding control and whether a pump-controlled or compressor-controlled diaphragm expansion vessel is used. When the signal is applied, the pump switches on. The filling operation takes place until the level set on the control of the expansion vessel is reached.

### 11.2.2. Pressure-controlled [P]

Control takes place via the pressure sensor that is integrated in the module. When the system pressure has dropped to the activation pressure 'Fill command on', the pump switches on and operates until 'Fill command off' is reached.

In both control modes, the running time and filling quantities (if the system is equipped with a pulse water meter) are monitored. In addition to this, the pressure in the system is monitored. If the system pressure falls or rises beyond the working pressure range, an error message appears. The system activates degassing and filling until the pressure is back in the working range.

### 11.2.3. Filling off

The ENA 7-30 unit operates solely as an automatic de-aeration unit.

## 11.3. Monitoring

It is the primary purpose of the monitoring functions to detect errors in the system at an early point of time and to protect the system components to the largest possible extent by means of appropriate signals or by automatically shutting down the system. They are particularly intended for detecting leakages at an early stage and to limit leakages.

### 11.3.1. Make-up quantity (monitoring)

The operator can freely parameterise the make-up quantity. If the conditions described below are not satisfied, the system will indicate an error; the floating error contact will be opened until the error is manually acknowledged.

- The actual run time must not exceed a maximum time per cycle.
- The minimum interval between two cycles (pause) must not be shorter than the time programmed.

- The maximum number of cycles per time window must not exceed the number programmed in the run time window (e.g., not more than 3 cycles in the last 8 hours.) If a litres counter (IWZ in NFE1.2/2.2) is connected and activated, the operator can monitor a maximum filling quantity per cycle instead of the maximum filling time per cycle.

### 11.3.2. Pressure monitoring

The maximum allowable pressure and level should not be exceeded. Therefore, pressure deviations are signalled.

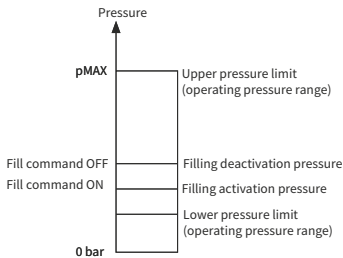

pMIN and pMAX are set on the working pressure limits and are not adjustable by the operator. pON and pOFF are adjustable within these limits.

### 11.3.3. Monitoring of quantity of water to be treated

If a water treatment module has been installed and the pulse water meter has been set to ON, the residual water quantity can be read at the lower right in the process menu. I.e.: if the residual water quantity has been correctly entered in the parameter menu 'Water treatment prior to commissioning'. If the quantity is zero litres, the centralised fault alarm will be tripped (if activated), and an error message will be initiated. Negative values mean that the permissible treated quantity (capacity) in litres has been exceeded. The ENA 7-30 continues to operate in such a case.

## 12. Appendix 3. Menu descriptions

### 12.1. Hardware menu

#### **ID number**

Can be parameterised only by the manufacturer and service personnel.

#### **Language**

The operator can choose between 17 languages. German (G2\_1) is the default setting on delivery.

#### **Litres counter (IWZ)**

Set this item to ON only if a pulse water meter (litres counter) is used. The pulse water meter can be used for directly controlling and monitoring the supplied make-up water. The default setting is OFF.

#### **Water treatment**

If a water treatment module has been integrated in the make-up water branch and the litres counter has been set to ON, the residual water quantity that can be read in litres in the process menu. When a quantity of zero litres is reached, the centralised fault alarm is tripped, and an error message will be displayed. Negative values mean that the allowable treatment quantity (capacity) has been exceeded. The make-up unit continues to operate even if the centralised fault alarm has been tripped. The operator must activate the water treatment function.

#### **Control mode**

(Make-up mode) The operator can operate the system in a level-controlled (controlled from an external pressureholding control) mode or in a pressure-controlled mode (default setting for normal gas-cushioned diaphragm expansion vessel).

The operator also can deactivate the make-up function.

#### **Operating mode**

The unit is shipped from the factory with the fast mode activated. Upon expiry of the fast interval, the unit automatically switches to normal. However, the operator can change the operating mode at any time. The hand mode can be activated for servicing purposes only. Vacuum test serves for ensuring the de-aerating operation and for checking leakages in the system. This function must be used when the unit is commissioned and each time the unit is put back into service after maintenance. After the test has been completed, the unit must be switched back to the fast mode.

#### **Sensor / Motor protection**

Already been parameterised. Factory setting.

## Common failure

If set to ON (item ticked), the common failure will be tripped upon the activation of the respective error message. The default setting is ON. It is possible to deactivate the following centralised fault alarms: 'Exchange module' and 'Next maintenance'.

- Exchange module: the water treatment capacity is exhausted. If it is set to ON, a centralised fault alarm will be tripped. The unit continues to operate. If set to OFF, no centralised fault alarm will be tripped.
- Next maintenance: maintenance date has been reached. If it is set to ON, the centralised fault alarm will be tripped and the unit continues to operate. If set to OFF, no centralised fault alarm will be tripped.

## 12.2.Parameter menu

Item	Factory setting
<b>Duration of turbo</b>	
- Remaining fast run time up to automatic change to normal mode	10 hours
<b>Pause normal degaz</b>	
- Duration of pause between end of evacuation time and beginning of pump run	15 minutes
- Pause ON (beginning of night pause)	06:00 pm
- Pause OFF (end of night pause)	08:00 am
<b>Degassing</b>	
- Pump run time	Pressure dependent [s]
- De-aeration time	60 seconds
<b>System pressure</b>	
- pON: depending on the system type	ENA 7 -> 1.5 bar ENA 10 -> 1.5 bar ENA 20 -> 3.0 bar ENA 30 -> 5.0 bar
- pOFF: depending on the system type	ENA 7 -> 2.0 bar ENA 10 -> 2.0 bar ENA 20 -> 4.0 bar ENA 30 -> 6.0 bar
- Lower pressure limit (lower working pressure limit)	Depending on the system type
- Upper pressure limit (upper working pressure limit)	Depending on the system type
- Special system pressure (irrelevant for the operator)	Factory setting
<b>Litres counter</b>	
- Litre/pulse: pulse water meter (can be set only by service personnel)	10 litre/pulse
- Error litres counter: monitoring of delay of cycle of litres counter	40 minutes
<b>Water treatment</b>	100 litres
- Treatment capacity in case of integrated water softening module	100 litres

**Filling quantity:**

Based on a continually referenced preceding period of time (time window), the unit allows using a certain number of filling cycles that are separated by pauses from one another. Cycles, pauses and time windows (time spending) can be freely parameterised.

**Example: (default setting)**

In the last 480 minutes (time spending) the make-up water quantity per cycle must not exceed 50 litres. Moreover, it is not permissible to supply this quantity during this time more than three times, and the pauses between the cycles must be 5 minutes at a minimum.

Item	Factory setting
Max quantity/filling	
- Maximum allowable quantity per cycle (also per cycle) with integrated and configured pulse water meter. See section Monitoring: make-up quantity	150 litres
Max time/filling	
- Maximum allowable make-up time per cycle (also per cycle). See section Monitoring: monitoring of run time	20 minutes
Min. interval betw. 2 cycles	
- Minimum interval between two cycles (pause)	5.0 minutes
Max cycles/time spend	
- Maximum number of cycles per time window	3
Time spending	
- Size of time window	480 minutes

Item	Factory setting
Time and date	
- Summer time on: starting month (summer time ON is 00 for regions without change between times)	03
- Summer time off: ending month (summer time OFF=00 for regions without change between times)	10
- Maintenance gap: maintenance interval 0 .. 800 days	365 days
- Pressure sensor min.value	0.0 bar
- Pressure sensor max.value	10.0 bar

Note that the values in the filling quantity menu are interdependent. Therefore, it may be necessary to first parameterise another value before the actual value becomes accessible within the intended limits. Similarly, setting ranges may be limited by the dependencies. It is advisable, for instance, to first parameterise a sufficiently sized time window before defining the pauses and the number and length of cycles

## 12.3. Service menu

### **Project number**

Factory settings; not be programmed by the operator.

### **Software version**

Readable entry made by manufacturer.

### **Start**

Enter the time and date of the start (traceability) by pressing Start. Before pressing, the date and time must have been correctly set.

### **Maintenance**

The date of the next maintenance is indicated in parentheses. When this time is reached, the centralised fault alarm is optionally tripped, and a fault message is displayed to remind the operator. If it is acknowledged, it will be displayed again after seven days unless 'Maintenance done' has been pressed, thus indicating that the maintenance has already been carried out. The time and date of the last maintenance as well as the code level are indicated in the upper two lines.

### **Error list**

Shows the last acknowledged 250 errors together with time and date.

### **Value statistics**

Display of various statistic data.

### **Refill statistics**

Display of the last 200 make-up operations together with date, time and duration of the make-up operations and the number of litres supplied (if a pulse water meter is used). The number of supplied litres displayed may be zero, although water has been fed into the system, if the makeup quantity was smaller than the pulse rate of the pulse water meter. Similarly, the actual quantity of water supplied may be smaller than the value registered by the pulse water meter.

### **Change entry code**

Change to another access code. For the operator, only code 000001 is possible and required.

# 13. Appendix 4. Examples

## 13.1. ENA 7-30 with NFE1.1 and a diaphragm expansion vessel in a heating system

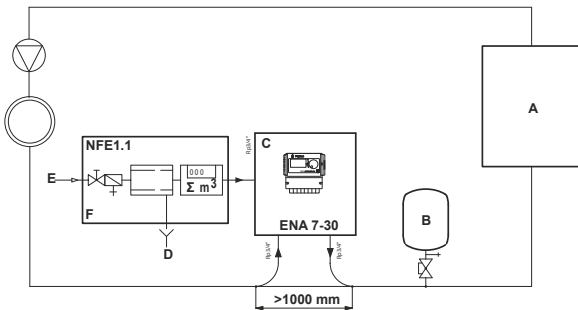

<b>A</b>	Heater
<b>B</b>	Diaphragm expansion vessel
<b>C</b>	ENA 7-30
<b>D</b>	Waste water (Drain)
<b>E</b>	Make-up water inlet
<b>F</b>	NFE 1.1

**Do not use nominal bores smaller than indicated for the lengths of the lines concerned! The lines should be as short as possible!**

- DN20 < 10 m
- DN25 < 20 m
- DN32 < 30 m

## 13.2. ENA 7-30 with NFE1.2 and a compressor controlled pressure level in a heating system

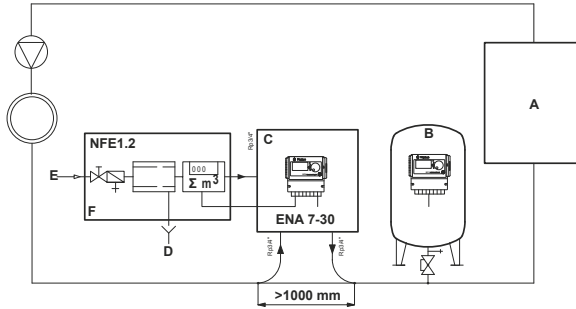

<b>A</b>	Heater
<b>B</b>	Diaphragm expansion vessel
<b>C</b>	ENA 7-30
<b>D</b>	Waste water (Drain)
<b>E</b>	Make-up water inlet
<b>F</b>	NFE 1.2

Do not use nominal bores smaller than indicated for the lengths of the lines concerned! The lines should be as short as possible!

DN20 < 10 m  
 DN25 < 20 m  
 DN32 < 30 m





# flamco

## Contact us !

We supply products for the installation industry in more than 70 countries. This is done from Flamco sales offices and via distributors who know the local market, and can give you the right advice at all times.

### **Aalberts hydronic flow control**

#### **The Netherlands**

Postbus 30110 / 1303 AC Almere  
Fort Blauwkapel 1 / 1358 AD Almere

+31 (0)36 526 2300 / [nl.nfo@aalberts-hfc.com](mailto:nl.nfo@aalberts-hfc.com)

[flamco.aalberts-hfc.com](http://flamco.aalberts-hfc.com)