

Data Sheet | Item Number: 280-502/281-593

Component terminal block; double-deck; with end plate and direct connection to DIN-rail; with 1.5KE39CA TVS diode; 24 VAC; for DIN-rail 35 x 15 and 35 x 7.5; 2.5 mm²; CAGE CLAMP®; gray

<https://www.wago.com/280-502/281-593>

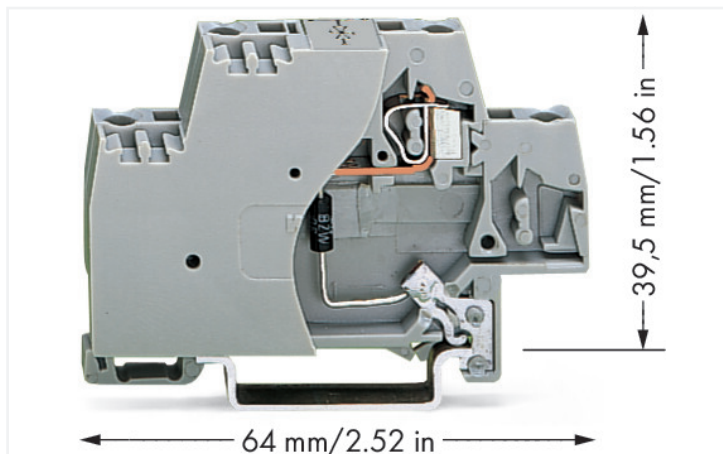

Color: ■ gray

Similar to illustration

Similar to illustration

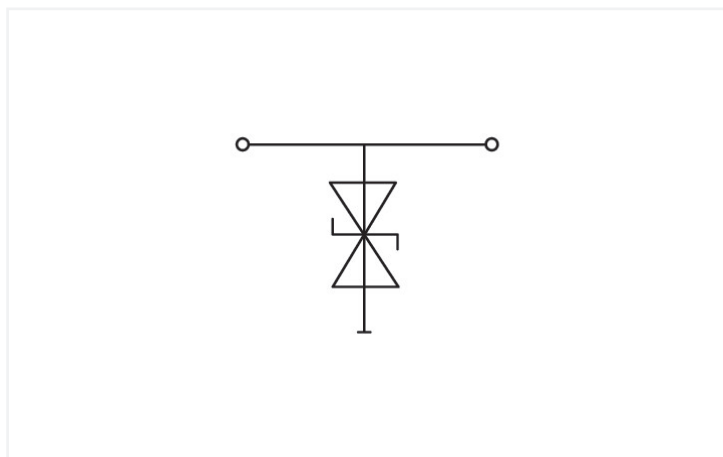

Short description:

This component terminal block with surge suppression device, end plate and direct connection to the DIN-35 rail is equipped with a TVS diode.

Features:

- Protect your system against overvoltage
- Slim, space-saving design
- Control operational costs by preventing expensive, unplanned downtime
- High operational reliability and system uptime

Notes

Safety Information	<ul style="list-style-type: none"> - Installation must be performed by qualified personnel only. - The DIN-rail must be grounded. - The input current must be protected by a suitable fuse. - Protection against contact with stored charges must be ensured. - Do not insert or remove pluggable modules when energized. - The IP20 protection rating must be maintained in the assembled state or when using an end/intermediate plate compatible with the rail-mount terminal block.
--------------------	---

Electrical data

Nominal operating voltage	24 VAC
Maximum continuous voltage	26 VAC
Rated continuous current	20 A
Nominal discharge current (8/20 μ s) (line)	143 A
Protection level (8/20 μ s)	\leq 70 VAC
Capacitance	\leq 2.4 nF

Connection Data

Connections (number)	2
Connection technology	CAGE CLAMP®
Solid conductor	0.08 ... 2.5 mm ² / 28 ... 14 AWG
Fine-stranded conductor	0.08 ... 2.5 mm ² / 28 ... 14 AWG
Strip length	8 ... 9 mm / 0.31 ... 0.35 inches

Physical data

Width	10 mm / 0.394 inches
Height	64 mm / 2.52 inches
Depth from upper-edge of DIN-rail	39.5 mm / 1.555 inches

Mechanical data

Design	with end plate; with direct connection to DIN-rail
Mounting type	DIN-35 rail

Material data

Color	gray
Insulation material (main housing)	Polyamide (PA66)
Material group	I
Flammability class per UL94	V0
Fire load	0.273 MJ
Weight	12.1 g

Environmental requirements

Processing temperature	-35 ... +85 °C
------------------------	----------------

Commercial data

Product Group	1 (Rail Mounted Terminal Blocks)
PU (SPU)	50 (1) pcs
Packaging type	Box
Country of origin	DE
GTIN	4017332262804
Customs tariff number	85369010000

Product Classification

UNSPSC	39121410
eCl@ss 10.0	27-14-11-27
eCl@ss 9.0	27-14-11-27
ETIM 9.0	EC000903
ETIM 10.0	EC000903
ECCN	NO US CLASSIFICATION

Environmental Product Compliance

CAS-No.	7439-92-1
REACH Candidate List Substance	Lead
RoHS Compliance Status	Compliant,With Exemption
RoHS Exemption	7(a) 7(c)-I
SCIP notification number (Austria)	95e9192e-f071-4d83-8409-c18073221e64
SCIP notification number (Belgium)	193c1160-d50f-4b81-8a5a-ec4ef292782f
SCIP notification number (Bulgaria)	675c1b7e-2103-4afc-8054-56ab3b7b953c
SCIP notification number (Czech Republic)	78bde514-2103-480f-89e7-54c21bc224ef
SCIP notification number (Denmark)	99e3a8bc-30ce-4c5b-8262-5330d8bc8323
SCIP notification number (Finland)	2b85bff3-a0a1-47a4-b571-0b84f50eb49f
SCIP notification number (France)	8abc4cee-978e-46cc-8158-c2229c9e4247
SCIP notification number (Germany)	83f5b04c-86c1-4867-a5f7-02d0f2f11a43
SCIP notification number (Hungary)	08d34709-ee98-4dda-b823-ef37d7ced77b
SCIP notification number (Italy)	90acd66f-1d69-4383-913a-16cf757bf370
SCIP notification number (Netherlands)	6e5fdeac-75f4-4ef1-b5a3-a32d48388d76
SCIP notification number (Poland)	0be15193-3fa6-46d8-9362-3f6d461b30e2
SCIP notification number (Romania)	4c1e77d5-1167-4713-96bb-9517050a2441
SCIP notification number (Sweden)	69fe95a5-dc8f-4c31-9359-37c0621cd9f3

Downloads

Environmental Product Compliance

Compliance Search

Environmental Product
Compliance
280-502/281-593



Documentation

Bid Text

280-502/281-593	19.02.2019	xml 3.31 KB	
280-502/281-593	11.02.2015	doc 25.00 KB	

CAD/CAE-Data

CAD data

2D/3D Models
280-502/281-593



CAE data

EPLAN Data Portal
280-502/281-593



WSCAD Universe
280-502/281-593



ZUKEN Portal
280-502/281-593



1 Compatible Products

1.1 Optional Accessories

1.1.1 Insulation stop

1.1.1.1 Insulation stop



Item No.: 280-470

Insulation stop; 0.08 - 0.2 mm² "s" (0.14 mm² "f-st"); 5 pieces/strip; white



Item No.: 280-471

Insulation stop; 0.25 - 0.5 mm²; 5 pieces/strip; light gray



Item No.: 280-472

Insulation stop; 0.75 - 1 mm²; 5 pieces/strip; black

1.1.2 Jumper

1.1.2.1 Jumper



Item No.: 280-492

Jumper; 2-way; insulated; gray

1.1.3 Marking

1.1.3.1 Marker



Item No.: 2009-145

Mini-WSB Inline; for Smart Printer; 1700 pieces on roll; stretchable 5 - 5.2 mm; plain; snap-on type; white



Item No.: 248-501

Mini-WSB marking card; as card; not stretchable; plain; snap-on type; white

1.1.4 Tool

1.1.4.1 Operating tool



Item No.: 210-720

Operating tool; Blade: 3.5 x 0.5 mm; with a partially insulated shaft; multicoloured