

Color: ■ gray

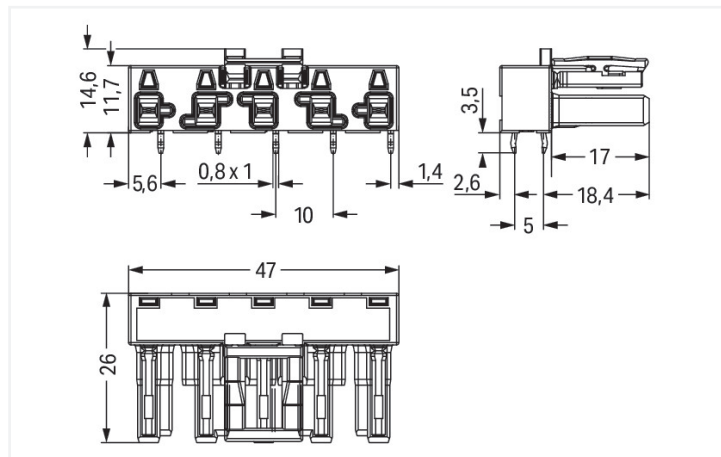

Dimensions in mm

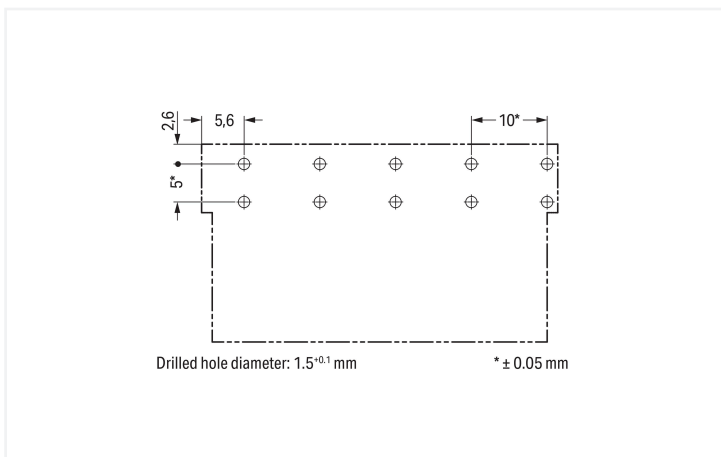

Dimensions in mm

#### Female connector/socket WINSTA® MIDI rated current 25 A

Consistently secure electrical installations through distinctive connection technology: The WINSTA® MIDI female connector/socket. Our giant selection of pluggable PCB connectors with various insertion directions and operating variants offers you the perfect solution for your application at any time. For greater security in electrical installations, the pcb connectors is equipped with mechanical protection against mismatching. Pcb connectors with B coding from the WINSTA® MIDI line are available in gray, light green, or pink, allowing you to distinguish different circuits, for example for pumps, lighting, or sun blinds. Usage-specific pole marking is possible, too. This pcb connectors can be used for a current load of up to 25 A. Thus, pcb connectors can also be used for high power loads. WINSTA® MIDI with Push-in CAGE CLAMP® spring pressure connection technology is found in a broad range of individual products you can use for quick, easy, flexible, and secure installation.

Push-in CAGE CLAMP® spring pressure connection technology – pluggable installation instead of laborious screw connections!

The WINSTA® Pluggable Connection System is ideally tailored to the very strict requirements of building installation. It makes electrical installation pluggable, and thus more efficient, even more reliable, and error-free. Using this pre-assembled system reduces time spent on assembly and errors during installation at the construction site. Choose durability and quality – with protection against mismatching from WAGO makes the installation of electrical components significantly easier.

- pcb connectors with protection against mismatching
- for automation controllers
- with B coding for use in process automation, such as lighting technology
- convenient installation and commissioning

## Notes

Variants:	Other pole markings Other versions (or variants) can be requested from WAGO Sales or configured at <a href="https://configurator.wago.com/">https://configurator.wago.com/</a> .
-----------	---

## Electrical data

Ratings per	IEC/EN 60664-1			Ratings per IEC/EN – Notes	
Overvoltage category	III	III	II	Rated current (note)	25 A for 3-pole load 20 A for 4- and 5-pole load
Pollution degree	3	2	2		
Nominal voltage	400 V	-	-		
Rated impulse withstand voltage	6 kV	-	-		
Rated current	25 A	-	-		

## Approvals per

## UL 1977

Rated voltage	600 V
Rated current	23 A

## General information

Note on contact resistance	approx. 1 mΩ of contact resistance approx. 0.25 mΩ contact transition plug/ socket
----------------------------	--

## Connection Data

Total number of potentials	5
----------------------------	---

## Connection 1

Pole number	5
-------------	---

## Physical data

Pin spacing	10 mm / 0.394 inches
Width	47 mm / 1.85 inches
Height	18.1 mm / 0.713 inches
Height from the surface	14.6 mm / 0.575 inches
Depth	26 mm / 1.024 inches
Solder pin length	3.5 mm
Solder pin dimensions	1 x 0.8 mm
Drilled hole diameter with tolerance	1.5 <sup>(-0.1 ... +0.1)</sup> mm

## Mechanical data

Use	Control technology
Coding	B
Variable coding	Yes
Marking	1 2 3 4 5
Potential marking	1 2 3 4 5
Mating force of a plug-in connection	approx. 20 ... 70 N (depending on pole number)
Retention force of a plug-in connection	Locked: > 80 N
Unmating force of a plug-in connection	Unlocked: approx. 20 ... 70 N (depending on pole number)
Number of mating cycles	200, without resistive load
Design	angled

### Plug-in connection

Contact type (pluggable connector)	Female connector/socket
Connector (connection type)	for PCB
Mismating protection	Yes
Note on mismating protection	All WINSTA® components are 100% protected against mismating when: a.) plugging different numbers of poles b.) plugging while rotated 180 c.) plugging while laterally staggered d.) plugging one pole
Mating direction to the PCB	0°
Locking lever	Yes
Locking of plug-in connection	Locking lever
Note on locking system	All connectors for mounted installations (snap-in versions for lighting fixtures or devices, all types of PCB and distribution connectors) are factory-equipped with locking levers to ensure plugs and sockets are securely locked. Additional locking levers are only required for flying leads (plug/socket).

### PCB contact

PCB contact	THT
Solder pin arrangement	2 in-line solder pins/pole
Number of solder pins per potential	2

### Material data

Note (material data)	<a href="#">Information on material specifications can be found here</a>
Color	gray
Insulation material (main housing)	Polyamide (PA66)
Flammability class per UL94	V0
Clamping spring material	Chrome-nickel spring steel (CrNi)
Contact material	Copper or copper alloy; surface-treated
Contact Plating	Tin
Fire load	0.198 MJ
Weight	10.5 g

### Environmental requirements

Processing temperature	-5 ... +40 °C
Continuous operating temperature	-35 ... +85 °C
Note on continuous operating temperature	Insulating parts for temperatures ≤ 105 °C

### Commercial data

Product Group	20 (Winsta)
PU (SPU)	50 pcs
Packaging type	Box
Country of origin	PL
GTIN	4017332802642
Customs tariff number	85366990990

**Product Classification**

UNSPSC	39121409
eCl@ss 10.0	27-44-06-05
eCl@ss 9.0	27-44-06-05
ETIM 9.0	EC002637
ETIM 10.0	EC002637
ECCN	NO US CLASSIFICATION

**Environmental Product Compliance**

RoHS Compliance Status	Compliant, No Exemption
------------------------	-------------------------

**Approvals / Certificates**

**General approvals** **Declarations of conformity and manufacturer's declarations**



Approval	Standard	Certificate Name
CCA DEKRA Certification B.V.	IEC 61984	NL-32104
CCA DEKRA Certification B.V.	EN 61984	2173495.01
cURus Underwriters Laboratories Inc.	UL 1977	E45171

Approval	Standard	Certificate Name
EU-Declaration of Conformity WAGO GmbH & Co. KG	-	-
UK-Declaration of Conformity WAGO GmbH & Co. KG	-	-

**Approvals for marine applications**





Approval	Standard	Certificate Name
ABS American Bureau of Shipping	-	24-0095977-PDA
DNV GL Det Norske Veritas, Germanischer Lloyd	-	TAE00001Z6
LR Lloyds Register	IEC 61984	LR22429487TA

**Downloads**

**Environmental Product Compliance**

<b>Compliance Search</b>
Environmental Product Compliance 770-845/011-000

## CAD/CAE-Data

CAD data	CAE data
2D/3D Models 770-845/011-000 	EPLAN Data Portal 770-845/011-000 
	ZUKEN Portal 770-845/011-000 

## 1 Compatible Products

## 1.1 System counterpart

## 1.1.1 Cable assembly

**Item No.: 771-9995/205-103**

pre-assembled connecting cable; Eca;  
 Plug/open-ended; 5-pole; Cod. B; (H)  
 05VV-F 5x1,0 mm<sup>2</sup>; 1 m; 1,00 mm<sup>2</sup>; gray

**Item No.: 771-9995/005-103**

pre-assembled interconnecting cable;  
 Eca; Socket/plug; 5-pole; Cod. B; (H)05VV-  
 F 5x1,0 mm<sup>2</sup>; 1 m; 1,00 mm<sup>2</sup>; gray

## 1.1.2 Male connector/plug

**Item No.: 770-255**

Plug; 5-pole; Cod. B; 4,00 mm<sup>2</sup>; gray

## 1.2 Required Accessories

## 1.2.1 Cover

## 1.2.1.1 Cover

**Item No.: 770-201**

Lockout cap; 12-pole, separable; for  
 sockets; Plastic; black

**Item No.: 770-221**

Lockout cap; 12-pole, separable; for  
 sockets; Plastic; white