

Operating Instructions

Fronius Symo GEN24

3.0 SC / 3.0 Plus SC / 4.0 SC / 4.0 Plus SC
5.0 SC / 5.0 Plus SC

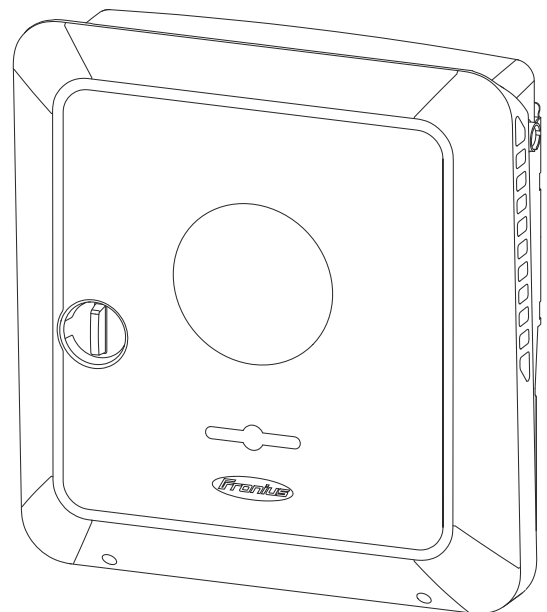

EN | Operating Instructions



Table of contents

General information	9
Safety information.....	11
Safety.....	11
Explanation of warnings and safety instructions.....	11
Safety instructions and important information.....	11
Environmental conditions.....	13
Electromagnetic fields.....	13
Data on noise emission values.....	13
EMC measures.....	13
Backup power.....	13
Ground conductor.....	15
Protection of people and equipment.....	16
Central grid and system protection.....	16
WSD (wired shutdown).....	16
RCMU.....	16
Insulation monitoring.....	16
AFCI - Arc Fault Circuit Interrupter (Arc Guard).....	16
Safe state.....	17
General.....	18
Information on the device.....	18
How information is presented in the document.....	19
Target group.....	19
Data security.....	19
Copyright.....	20
Fronius Symo GEN24 SC / Fronius Symo GEN24 Plus SC.....	21
Device concept.....	21
Function overview.....	21
Fronius UP.....	22
Scope of supply.....	22
Intended use.....	22
Thermal concept.....	23
Fronius Solar.web.....	23
Local communication.....	23
Different operating modes.....	25
Operating modes - Explanation of symbols.....	25
Operating mode - Inverter with battery.....	26
Operating mode - Inverter with battery and several Smart Meters.....	26
Operating mode - Inverter with battery, AC-coupled to another inverter.....	26
Operating mode - Inverter with battery and Ohmpilot.....	26
Operating mode - Inverter with battery and another inverter.....	27
Energy flow direction of the inverter.....	27
Operating states (only for battery systems).....	27
Energy-saving mode.....	29
General.....	29
Switch-off conditions.....	29
Switch-on conditions.....	29
Special case.....	29
Indication of energy saving mode.....	30
Suitable batteries.....	31
General.....	31
Fronius batteries.....	31
BYD batteries.....	32
LG FLEX.....	33
Manual system start.....	34
Requirements.....	34
Notification of system shutdown.....	34
Manual battery start after system shutdown.....	34

Starting backup power operation after a system shutdown	34
Operating controls and connections.....	35
Connection area	35
Connection area divider	36
Ground electrode terminal.....	36
DC disconnector.....	37
Data communication area.....	37
Button functions and LED status indicator	39
Schematic internal wiring of IOs	40
Backup power variant - PV Point (OP)	43
General.....	45
Explanatory note - PV Point/PV Point Comfort.....	45
PV Point (OP).....	45
PV Point Comfort.....	46
Installation	47
General.....	49
Quick-fastener system	49
System component compatibility	49
Installation location and position	50
Choosing the location of the inverter.....	50
Choosing the location of third-party batteries.....	51
Installation position of the inverter.....	52
Installing the mounting bracket and attaching the inverter	54
Selecting the mounting material.....	54
Properties of the mounting bracket.....	54
Do not deform the mounting bracket.....	54
Fitting the mounting bracket to a wall.....	54
Installing the mounting bracket on a mast or beam	55
Attaching the mounting bracket to mounting rails.....	56
Attaching the inverter to the mounting bracket.....	56
Requirements for connecting the inverter	57
Different cable types.....	57
Permissible cables for the electrical connection.....	57
Permitted cables for the data communication connection.....	58
Cable diameter of the AC cable.....	58
Cable diameter of the DC cable.....	59
Maximum alternating current fuse protection.....	59
Connecting the inverter to the public grid (AC side).....	61
Safety	61
Connecting the inverter to the public grid (AC side).....	61
Connecting solar module strings to the inverter	65
General information about PV modules.....	65
Safety	65
PV Generator, general.....	66
Module array configuration	66
Connecting solar module strings to the inverter	67
Connecting the battery to the inverter.....	71
Safety	71
Connecting the battery on the DC side.....	71
Connecting the LG FLEX ground conductor	74
Connecting backup power - PV Point (OP)	75
Safety	75
Installation.....	75
Testing backup power mode.....	79
Connecting the data communication cables.....	80
Modbus participants	80
Routing data communication cables	80
Connecting the battery communication cable	82
Terminating resistors.....	83

Installing the WSD (wired shutdown)	85
Closing and commissioning the inverter.....	86
Closing the inverter's connection area/housing cover, and commissioning	86
Starting the inverter for the first time.....	87
Installation with the app	87
Installation with the browser.....	88
De-energizing the inverter and switching it back on.....	89
De-energizing the inverter and switching it back on.....	89

Settings - User interface of the inverter 91

User settings.....	93
User login.....	93
Selecting languages	93
Device configuration	94
Components.....	94
Functions and I/Os.....	95
Demand Response Modes (DRM).....	96
Inverter.....	96
Energy management.....	101
Permitted maximum battery charge from the public grid	101
Battery management.....	101
Examples - Time-dependent battery control	102
Permitted battery control regulations.....	104
PV power reduction.....	106
Load management.....	106
Self-consumption optimization.....	107
System	108
General.....	108
Update.....	108
Setup wizard.....	108
Restoring factory settings	108
Event log.....	108
Information	108
License Manager	108
Licensing	109
Support	109
Communication.....	111
Network	111
Modbus.....	112
Cloud control.....	114
Solar API.....	114
Fronius Solar.web.....	114
Safety and grid requirements	116
Country setup	116
Requesting inverter codes in Solar.SOS.....	116
Absolute Generation Limit.....	117
Import limitation.....	117
Feed-in limit.....	117
Feed-in limit - examples.....	119
Multiple Inverter Control	120
I/O Power Management.....	123
Connection diagram - 4 relays.....	124
I/O power management settings - 4 relays	126
Connection diagram - 3 relays.....	126
I/O power management settings - 3 relays	128
Connection diagram - 2 relays.....	128
I/O power management settings - 2 relays	130
Connection diagram - 1 relay.....	130
I/O power management settings - 1 relay	132
Connecting the ripple control receiver with several inverters.....	132
Autotest (CEI 0-21).....	133

Options	135
Surge protection device (SPD).....	137
General.....	137
Safety.....	137
Scope of supply.....	137
De-energizing the inverter.....	138
Installation.....	139
Starting up the inverter.....	144
DC Connector Kit GEN24.....	146
General.....	146
General information about PV modules.....	146
Safety.....	146
Scope of supply.....	147
De-energizing the inverter.....	148
Installation.....	148
Starting up the inverter.....	153
PV Point Comfort.....	154
Safety.....	154
Scope of supply.....	155
De-energizing the inverter.....	155
Installation.....	156
Starting up the inverter.....	162
Configuring the PV Point Comfort.....	162
Testing backup power mode.....	163
Appendix	165
Service, maintenance and disposal.....	167
General.....	167
Maintenance.....	167
Cleaning.....	167
Safety.....	167
Operation in dusty environments.....	167
Disposal.....	169
Warranty provisions.....	170
Fronius manufacturer's warranty.....	170
Status codes and remedy.....	171
Display.....	171
Status codes.....	171
Technical data.....	172
Fronius Symo GEN24 3.0 SC / 3.0 Plus SC.....	172
Fronius Symo GEN24 4.0 SC / 4.0 Plus SC.....	175
Fronius Symo GEN24 5.0 SC / 5.0 Plus SC.....	179
WLAN.....	182
Technical data of surge protection device DC SPD type 1+2 GEN24.....	183
Explanation of footnotes.....	183
Integrated DC disconnecter.....	184
System circuit diagrams	185
Fronius Symo GEN24 and Fronius Reserva.....	186
Fronius Symo GEN24 with Fronius Reserva connected in parallel.....	187
Fronius Symo GEN24 and Fronius Reserva Pro.....	188
Fronius Symo GEN24 with Fronius Reserva Pro connected in parallel.....	189
Fronius Symo GEN24 and BYD Battery-Box Premium HV.....	190
Fronius Symo GEN24 with two BYD Battery-Box Premium HV connected in parallel.....	191
Fronius Symo GEN24 with three BYD Battery-Box Premium HV connected in parallel.....	192
Fronius Symo GEN24 and BYD Battery-Box HVS+/HVM+.....	193
Fronius Symo GEN24 with BYD Battery-Box HVS+/HVM+ connected in parallel.....	194
Fronius Symo GEN24 and LG FLEX.....	195
Surge protection device (SPD).....	196

Circuit diagrams—PV Point	197
Emergency power terminal—PV Point (OP).....	198
Circuit diagram - PV Point (OP) Australia.....	199
Backup power terminal - PV Point (OP) with battery only for France.....	200
Backup power terminal - PV Point (OP) manual changeover.....	201
PV Point Comfort.....	202
Dimensions of the inverter	203
Fronius Symo GEN24 SC / Fronius Symo GEN24 Plus SC.....	204

General information

Safety information

Safety



CAUTION!

Danger from crushing due to the incorrect handling of attachments and connection parts.

Injuries to limbs may result.

- ▶ Use the integrated grips when lifting up, putting down, and attaching the inverter.
- ▶ When fitting attachments, ensure that no limbs are located between the attachment and the inverter.
- ▶ Do not hold on to the individual poles on the terminals when locking and unlocking.

Explanation of warnings and safety instructions

The warnings and safety instructions in these instructions are intended to protect people from possible injury and the product from damage.



DANGER!

Indicates an immediately dangerous situation

Serious injury or death will result if appropriate precautions are not taken.

- ▶ Action step to escape the situation



WARNING!

Indicates a potentially dangerous situation

Death or serious injury may result if appropriate precautions are not taken.

- ▶ Action step to escape the situation



CAUTION!

Indicates a potentially dangerous situation

Minor or moderate injury may result if appropriate precautions are not taken.

- ▶ Action step to escape the situation

NOTE!

Indicates impaired work results and/or damage to the device and components

The warnings and safety instructions are an integral part of these instructions and must always be observed to ensure the safe and proper use of the product.

Safety instructions and important information

The device has been manufactured in line with the state of the art and according to recognized safety standards.



WARNING!

Incorrect operation or misuse

Serious to fatal injuries to the operator or third parties as well as damage to the device and other property of the operator may result.

- ▶ All persons involved in the commissioning, maintenance, and servicing of the device must be appropriately qualified and have knowledge of working with electrical installations.
- ▶ Read these operating instructions in full and follow them carefully and precisely.
- ▶ The operating instructions must always be kept to hand wherever the device is being used.

IMPORTANT!

In addition to the operating instructions, observe the following general and local rules:

- Accident prevention
- Fire protection
- Environmental protection

IMPORTANT!

Labels, warning notices, and safety symbols are located on the device. A description can be found in these operating instructions.

IMPORTANT!

All safety and danger notices on the device:

- Must be kept in a legible state
- Must not be damaged/marked
- Must not be removed
- Must not be covered, have anything stuck on them, or painted over



WARNING!

Tampered-with and non-functioning protection devices

Serious to fatal injuries as well as damage to the device and other property of the operator may result.

- ▶ Never bypass or disable protection devices.
- ▶ Any protection devices that are not fully functional must be repaired by an authorized specialist before the device is switched on.



WARNING!

Loose, damaged, or under-dimensioned cables

An electric shock can be fatal.

- ▶ Use undamaged, insulated, and adequately dimensioned cables.
- ▶ Fasten the cables according to the specifications in the operating instructions.
- ▶ Loose, damaged, or under-dimensioned cables must be repaired or replaced immediately by an authorized specialist.

NOTE!**Installations or modifications to the device**

The device may be damaged

- ▶ Do not carry out any alterations, installations, or modifications to the device without first obtaining the manufacturer's permission.
- ▶ Damaged components must be replaced.
- ▶ Only use original spare parts.

Environmental conditions

Operation or storage of the device outside the stipulated area will be deemed as not in accordance with the intended use.

Electromagnetic fields

During operation, due to the high electrical voltages and currents, local electromagnetic fields (EMF) occur in the environment around the inverter and the Fronius system components as well as in the area of the PV modules including the supply lines.

In the case of exposure to humans, the required limit values are observed when the products are used in line with the intended use and the recommended distance of at least 20 cm is observed.

If these limit values are complied with, according to current scientific knowledge, no health-endangering effects from EMF exposure are to be expected. If wearers of prostheses (implants, metal parts in and on the body) as well as active physical aids (pacemakers, insulin pumps, hearing aids, etc.) are in the vicinity of components of the PV system, they must consult with the responsible doctor regarding possible health risks.

Data on noise emission values

The sound pressure level of the inverter is indicated in the [Technical data](#).

The cooling of the device takes place via an electronic temperature control system at the lowest possible noise level and depends on the power used, ambient temperature, and the soiling level of the device, etc.

It is not possible to provide a workplace-related emission value for this device, because the actual sound pressure level is heavily influenced by the installation situation, the power quality, the surrounding walls, and the properties of the room in general.

EMC measures

In certain cases, even though a device complies with the standard limit values for emissions, it may affect the application area for which it was designed (e.g., when there is equipment that is susceptible to interference at the same location or if the site where the device is installed is close to either radio or television receivers). If this is the case, the operator is obliged to take action to rectify the situation.

Backup power

This system has backup power functions. A backup power supply can be established in the event of a failure in the public grid.

If an automatic backup power supply is installed, attach the [backup power supply warning notice](https://www.fronius.com/en/solar-energy/installers-partners/downloads?searchword=42,0409,0275) (https://www.fronius.com/en/solar-energy/installers-partners/downloads?searchword=42,0409,0275) to the electrical distributor.



WARNING!

Danger due to electrical voltage on live parts of the PV system

Depending on the irradiance conditions and the battery state of charge, the backup power supply is automatically deactivated and activated. This can cause the backup power supply to unexpectedly return from standby mode. This can result in serious personal injury and damage to property.

- ▶ Disconnect the inverter on the network side before performing maintenance and installation work in the home network.
- ▶ Set the integrated DC disconnect on the inverter to the "Off" switch position to end the backup power supply.

Test the function of the residual current devices for the backup power supply at least every 6 months.

A description of how to run the test mode can be found in the [backup power checklist](https://www.fronius.com/en/solar-energy/installers-partners/downloads?searchword=42,0426,0365) (https://www.fronius.com/en/solar-energy/installers-partners/downloads?searchword=42,0426,0365).

Influencing factors on the total output in backup power mode:

Reactive power

Electrical loads with a power factor not equal to 1 require active power as well as reactive power. The reactive power places a further load on the inverter. Use the current resulting from the active and reactive power for the correct calculation of the total power. The rated power of the loads is not relevant.

Devices with a high reactive power are mainly electric motors, such as:

- Water pumps
- Circular saws
- Fans

High starting/start-up current

Electrical loads that need to accelerate a large mass generally require a high starting/start-up current. This can be up to ten times the nominal current. The maximum current of the inverter is available for the starting/start-up current. Loads with too high a starting/start-up current cannot, therefore, be started/operated, even though the nominal power of the inverter suggests otherwise. Therefore, consider the connected load power and the starting/start-up current when sizing the backup power circuit.

Devices with a high starting/start-up current include:

- Devices with electric motors (e.g., lift platforms, circular saws, workbenches)
- Devices with a high transmission ratio and flywheel mass
- Devices with compressors (e.g., compressed air compressors, air-conditioning systems)

IMPORTANT!

Very high start-up currents can temporarily distort or interrupt the output voltage. Avoid simultaneous operation of electronic devices in the same backup power circuit.

Unbalanced load

When dimensioning three-phase backup power circuits, consider the total output power and the powers per phase of the inverter.

IMPORTANT!

Only operate the inverter within the limits of its technical capabilities. Operation outside of its technical capabilities can cause the inverter to shut down.

Ground conductor

Connection of a point in the device, system, or installation to ground to protect against electric shock in the event of a fault. When installing an inverter from safety class 1 (see [Technical data](#)), a ground conductor connection is required.

When connecting the ground conductor, ensure that it is secured to prevent unintentional disconnection. All of the points listed in the chapter headed [Connecting the inverter to the public grid \(AC side\)](#) on page 61 must be observed. When using cable glands, ensure that the ground conductor is last to be subjected to a load in the event of a failure of the cable gland. The respective national standards and regulations and requirements for minimum cross-section must be observed when connecting the ground conductor.

Protection of people and equipment

Central grid and system protection

The inverter offers the option to use the integrated AC relays as section switches in conjunction with a central grid and system protection unit (in accordance with VDE-AR-N 4105:2018:11 §6.4.1). For this purpose, the central trigger device (switch) must be integrated into the WSD chain as described in chapter [WSD \(wired shutdown\)](#) on page 16.

WSD (wired shutdown)

The wired shutdown (WSD) interrupts the inverter's grid power feed if the trigger device (switch, e.g., Emergency Stop or fire alarm contact) has been activated.

If an inverter (slave) fails, it is bypassed and the other inverters continue operating. If a second inverter (slave) or the inverter (master) fails, the operation of the entire WSD chain is interrupted.

For installation, see [Installing the WSD \(wired shutdown\)](#) on page 85.

RCMU

The inverter is equipped with an RCMU (RCMU = residual current monitoring unit) according to IEC 62109-2 and IEC63112. It monitors residual currents from the PV module up to the AC output and disconnects the inverter from the grid when an improper residual current is detected.

Insulation monitoring

In the case of photovoltaic systems with ungrounded PV modules, the inverter checks the resistance between the positive or negative pole of the photovoltaic system and the ground potential before starting grid power feed operation. In the event of a short circuit between the DC+ or DC- cable and ground (e.g., due to inadequately insulated DC cables or defective PV modules), feeding into the public grid is prevented.

AFCI - Arc Fault Circuit Interrupter (Arc Guard)

An AFCI (Arc Fault Circuit Interrupter) protects against arc faults and, in the narrower sense, is a protection device in the event of contact errors. The AFCI evaluates faults that occur in the current and voltage flow on the DC side using an electronic circuit and shuts down the circuit if a contact error is detected. This prevents overheating at poor contact points and, ideally, possible fires.

CAUTION!

Danger from faulty or incorrect DC installation.

This may result in a risk of damage and, as a consequence, risk of fire in the PV system due to prohibited thermal loads that occur during an arc.

- ▶ Check the plug connections to ensure that they are correct.
- ▶ Repair faulty insulation correctly.
- ▶ Perform connection work in line with the instructions.

IMPORTANT!

Fronius will not bear any costs that may arise due to a detected electric arc and

its consequences. Fronius accepts no liability for damage which may occur despite the integrated Arc Fault Circuit Interrupter/interruption (e.g., due to a parallel arc).

IMPORTANT!

Active PV module electronics (e.g., power optimizers) can impair the function of the Arc Fault Circuit Interrupter. Fronius cannot guarantee the correct function of the Arc Fault Circuit Interrupter in combination with active PV module electronics.

Reconnection behavior

Grid power feed operation is interrupted for at least 5 minutes after an arc has been detected. Depending on the configuration, grid power feed operation is then automatically resumed. If several arcs are detected within a period of 24 hours, grid power feed operation can also be permanently interrupted until a manual reconnection has been performed.

Safe state

If one of the following safety devices is triggered, the inverter switches to the safe state:

- WSD
- Insulation monitoring and
- RCMU
- AFCI

In the safe state, the inverter no longer feeds energy in and is disconnected from the grid by the AC relay opening.

General

Information on the device



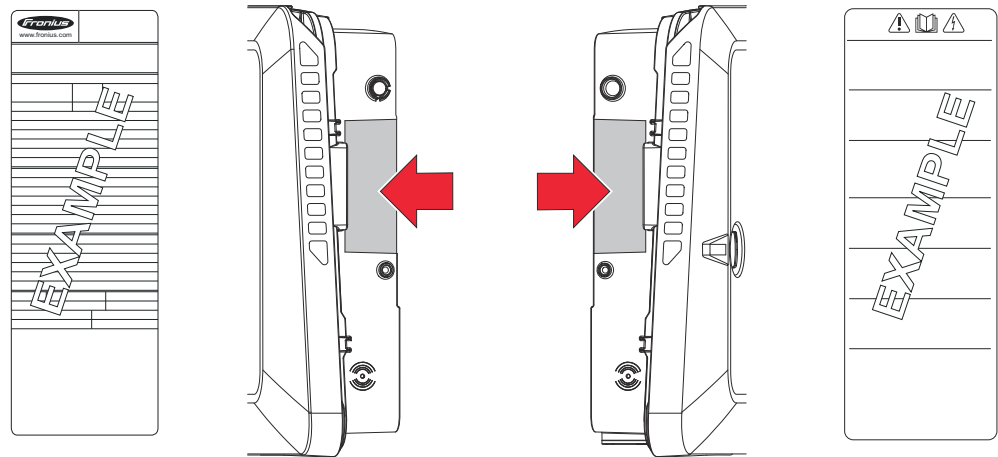

Technical data, warning notices, labels, and safety symbols are located on the inverter. This information must be kept in a legible condition and must not be removed, covered, pasted over, or painted over. The notices and safety symbols warn against incorrect operation, which may result in serious injury and property damage.



Symbols on the rating plate:

-  CE label – confirms compliance with applicable EU directives and regulations.
-  WEEE marking – waste electrical and electronic equipment must be collected separately and recycled in an environmentally sound manner in accordance with the European Directive and national law.
-  RCM marking – tested according to the requirements of Australia and New Zealand.
-  CMIM marking – tested according to IMANOR requirements for import regulations and compliance with Moroccan standards.

Safety symbols:

-  Integrated switch disconnecter on the input side of the inverter with switch-on, switch-off, and isolating function according to IEC 60947-3 and AS 60947.3. The values required by the applicable standard for the solar +60°C are given.
-  Risk of serious injury and property damage due to incorrect operation.
-  Do not use the functions described here until you have fully read and understood the following documents:
 - These operating instructions.
 - All operating instructions for the system components of the photo-voltaic system, especially the safety rules.
-  Dangerous electrical voltage.
-  Allow the capacitors of the inverter to discharge (2 minutes).

Warning notice text:

WARNING!

An electric shock can be fatal. Before opening the device, ensure that the input and output sides are de-energized and disconnected.

How information is presented in the document

The conventions regarding how information is presented in the document, which are set out below, have been defined in order to increase the readability and comprehensibility of the document.

Application notes

IMPORTANT! Indicates application notes and other useful information. It does not indicate a harmful or dangerous situation.

Software

Software functions and elements of a graphical user interface (e.g., buttons, menu items) are highlighted in the text with this **mark up**.

Example: Click **Save**.

Instructions for action

1 Action steps are displayed with consecutive numbering.

- ✓ *This symbol indicates the result of the action step or the entire instruction.*
-

Target group

This document provides detailed information and instructions to ensure that all users can use the device safely and efficiently.

- The information is intended for the following groups of people:
 - **Technical specialists:** People with appropriate qualifications and fundamental electronic and mechanical knowledge, who are responsible for the installation, operation, and maintenance of the device.
 - **End users:** People that use the device in daily operation and want to understand its basic functions.
 - Regardless of any qualifications, only perform the activities listed in this document.
 - All persons involved in the commissioning, maintenance, and servicing of the device must be appropriately qualified and have knowledge of working with electrical installations.
 - The definition of professional qualifications and their applicability are subject to national law.
-

Data security

With regard to data security, the user is responsible for:

- Backing up any changes made to the factory settings
- Saving and storing personal settings

NOTE!**Data security for network and Internet connection**

Unsecured networks and a lack of safeguards can result in data loss and unauthorized access. Observe the following points for safe operation:

- ▶ Operate inverters and system components on a private, secure network. A WiFi network is considered secure if security standard WPA 2 is satisfied as a minimum.
- ▶ Keep the network devices (e.g., WiFi routers) up to date with the latest technology.
- ▶ Keep the software and/or firmware updated.
- ▶ Use a wired network to ensure a stable data connection.
- ▶ For security reasons, do not make inverters and system components accessible from the Internet via port forwarding or Port Address Translation (PAT).
- ▶ Use the solutions provided by Fronius for monitoring and remote configuration.
- ▶ The optional communication protocol Modbus TCP/IP¹⁾ is an unsecured interface. Only use Modbus TCP/IP if no other secured data communication protocol (MQTT²⁾) is possible (e.g., compatibility with older Smart Meters).

¹⁾ TCP/IP - Transmission Control Protocol/Internet Protocol

²⁾ MQTT - Message Queuing Telemetry Protocol

Copyright

Fronius International GmbH retains the copyrights of these operating instructions.

Text, illustrations, and other media correspond to the technical state of the art at the time of publication. Fronius reserves the right to make changes. If you have any suggestions for improvement or have found a mistake in this document, we would be most grateful for your comments.

Fronius Symo GEN24 SC / Fronius Symo GEN24 Plus SC

Device concept

The inverter transforms the direct current generated by the PV modules into alternating current. This alternating current is fed into the public grid and synchronized with the mains voltage in use. Moreover, the solar energy can also be stored in a connected battery for later use.

The inverter is intended for use in grid-connected photovoltaic systems. The inverter has a backup power function and switches to backup power mode if it has been wired accordingly*.

The inverter automatically monitors the public grid. Whenever conditions in the electric grid are inconsistent with standard conditions (e.g., grid switch-off, interruption), the inverter will immediately stop producing power and interrupt the supply of power into the grid.

The grid is monitored by monitoring the voltage, frequency, and islanding conditions.

After installation and commissioning, the inverter's operation is fully automatic; the inverter draws the maximum possible power from the solar modules. Depending on the operating point, this power is used in the home, stored in a battery*, or fed into the grid.

As soon as the energy provided by the solar modules is no longer sufficient, the power from the battery is fed into the home network. Depending on the setting, power may also be obtained from the public grid in order to charge the battery*.

When its temperature gets too high, the inverter automatically reduces the output or charging power, or switches off completely, in order to protect itself. Reasons for the temperature being too high include a high ambient temperature or insufficient heat dissipation (for example, inadequate heat dissipation when installed in switch cabinets).

* Depending on the device variant, suitable battery, corresponding cabling, settings, and local standards and regulations.

Function overview

Function	Symo GEN24 SC	Symo GEN24 Plus SC
Backup power variant - PV Point (OP)	✓	✓
Battery connection*	optionally available**	✓
Backup power variant - Full Backup	✗	✗

* For suitable batteries, see chapter [Suitable batteries](#).

** The functions are optionally available via Fronius UP (see chapter [Fronius UP](#)).

Fronius UP

With Fronius UP*, optionally available functions can be added to the inverter by the authorized specialist company (see chapter [Function overview](#)).

* The availability of Fronius UP is country-specific. Click here for further information on [availability](#).

Scope of supply

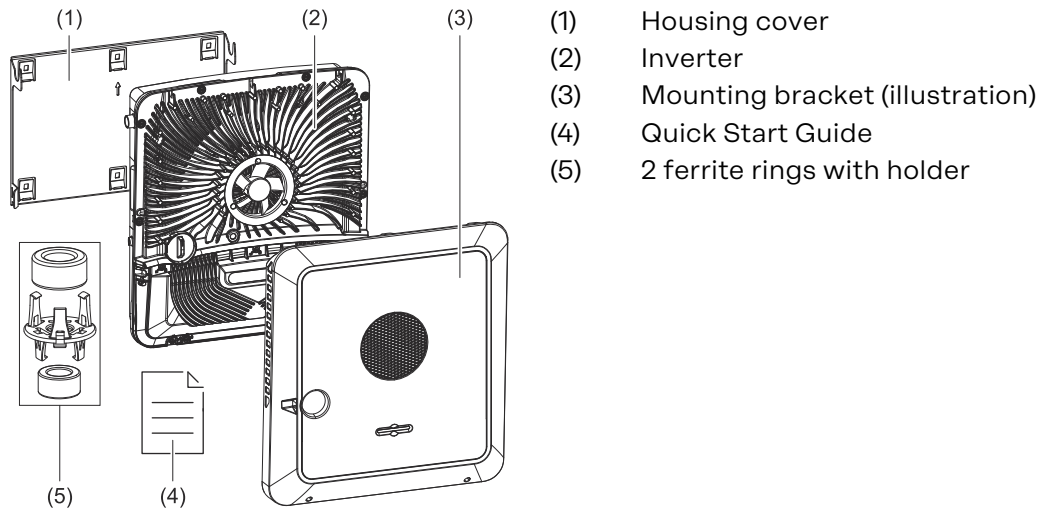

Intended use

The inverter is designed to convert direct current from PV modules into alternating current and feed this power into the public grid. A backup power mode* is possible if the wiring is set up accordingly.

Intended use also means:

- Carefully reading and following all the instructions as well as complying with the safety and danger notices in the operating instructions
- Installation in accordance with the chapter headed [Installation](#), from page [47](#)

Follow all grid operator regulations regarding energy fed into the grid and connection methods.

The inverter is a grid-connected inverter with backup power function and is not a stand-alone inverter. The following restrictions in backup power mode must therefore be observed:

- The inverter may be operated for max. 2000 operating hours in backup power mode
- The inverter may be operated for more than 2000 operating hours in backup power mode provided 20% of the grid power feed operating time of the inverter is not exceeded at the time in question

* Depending on the device variant, suitable battery, corresponding cabling, settings, and local standards and regulations.

Thermal concept

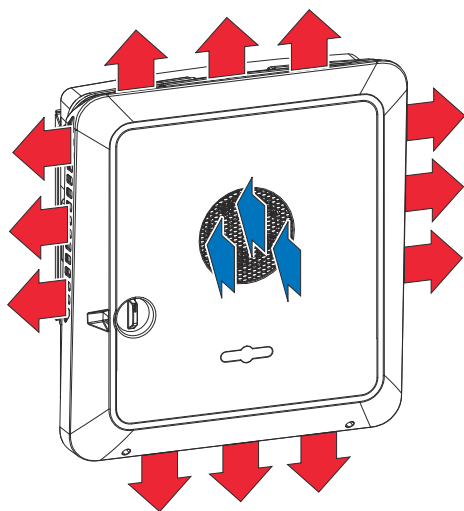

Ambient air is drawn in at the front of the device by the fan and blown out at the sides. The even heat dissipation allows several inverters to be installed next to each another.

NOTE!

Risk due to insufficient cooling of the inverter.

This may result in a loss of power in the inverter.

- ▶ Do not block the fan (e.g., with objects that protrude through the touch guard).
- ▶ Do not cover the ventilation slots, even partially.
- ▶ Make sure that the ambient air can always flow through the inverter's ventilation slots unimpeded.

Fronius Solar.web

System owners and installers can easily monitor and analyze the PV system using Fronius Solar.web or Fronius Solar.web Premium. With the appropriate configuration, the inverter transmits data such as power, yield, load, and energy balance to Fronius Solar.web. More detailed information can be found at [Solar.web - Monitoring & analysis](#).

Configuration is carried out via the Setup wizard, see chapter [Installation with the app](#) or [Installation with the browser](#).

Requirements for configuration:

- Internet connection (download: min. 512 kbit/s, upload: min. 256 kbit/s)*.
 - User account at solarweb.com.
 - Completed configuration using the Setup wizard.
- * These specifications do not provide an absolute guarantee of flawless operation. High error rates in the transmission, fluctuating receptions or misfires can have an adverse effect on data transfer. Fronius recommends on-site testing to ensure that the connections meet the minimum requirements.

Local communication

The inverter can be found via the Multicast DNS (mDNS) protocol. We recommend searching for the inverter using the assigned host name.

The following data can be called up via mDNS:

- NominalPower
- Systemname
- DeviceSerialNumber
- SoftwareBundleVersion

Different operating modes

Operating modes - Explanation of symbols

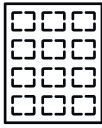

PV module

generates direct current



Fronius GEN24 inverter

converts direct current into alternating current and charges the battery (battery charging depends on the device variant, suitable battery, corresponding cabling, and the settings). The integrated system monitoring enables the inverter to be integrated into a network by means of WiFi.



Additional inverter in the system

converts the direct current into alternating current. However, it cannot charge a battery and is not available in backup power mode.



Battery

is coupled to the inverter on the direct current side, and stores electrical energy.



Fronius Ohmpilot

for using excess energy to heat water.



Primary meter

records the load curve of the system and makes the measured data available for energy profiling in Fronius Solar.web. The primary meter also controls the dynamic power of feeding in.



Secondary meter

records the load curve of individual loads (e.g., washing machine, lights, television, heat pump, etc.) in the load branch and makes the measured data available for energy profiling in Fronius Solar.web.



Loads in the system

are the loads connected in the system.



Additional loads and producers in the system

which are connected to the system by means of a Smart Meter.



PV Point

is a non-interruption-free 1-phase backup power circuit, which supplies electrical devices up to a maximum output of 3 kW, provided sufficient power is available from the PV modules or the battery.



Grid

supplies the loads in the system if insufficient power is being generated by the PV modules or supplied by the battery.

**Operating mode
- Inverter with
battery**

In order to be able to obtain the highest rate of self-consumption with your photovoltaic system, a battery can be used to store excess energy. The battery is coupled to the inverter on the direct current side. Multiple current conversion is therefore not required, and the efficiency is increased.

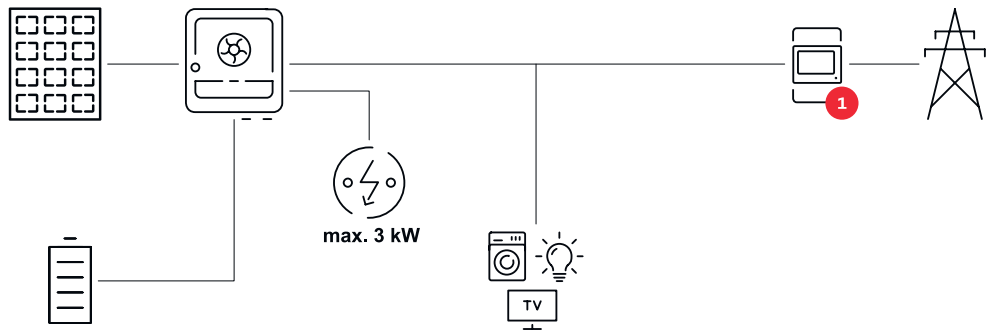

**Operating mode
- Inverter with
battery and sev-
eral Smart
Meters**

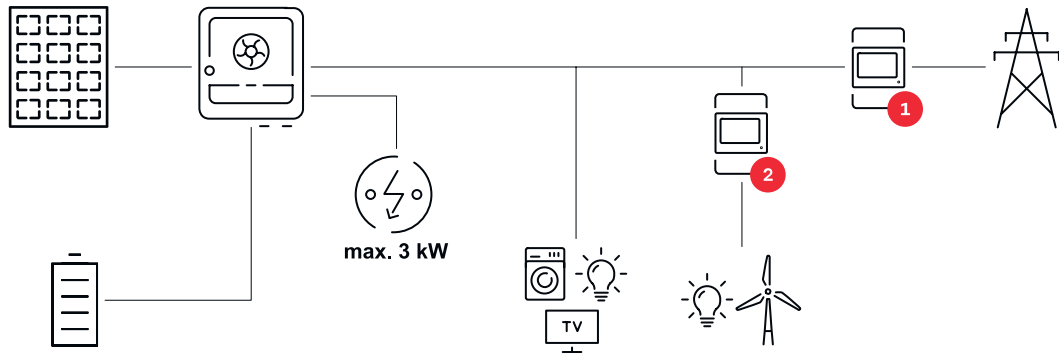

**Operating mode
- Inverter with
battery, AC-
coupled to an-
other inverter**

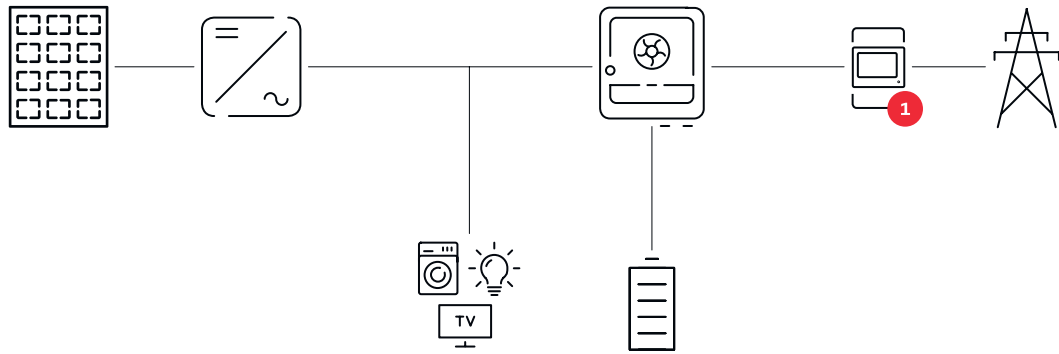

**Operating mode
- Inverter with
battery and
Ohmpilot**

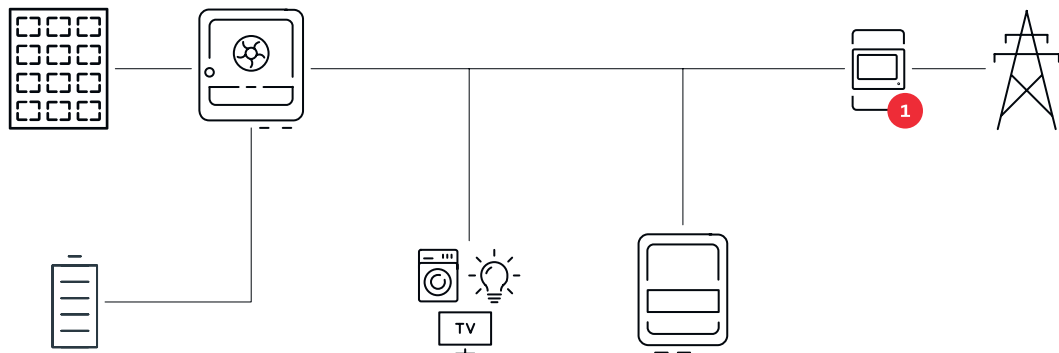

**Operating mode
- Inverter with
battery and an-
other inverter**

In the hybrid PV system, batteries may only be connected to an inverter with battery support. Batteries cannot be split between multiple inverters with battery support. Depending on the battery manufacturer, however, several batteries can be combined on one inverter.

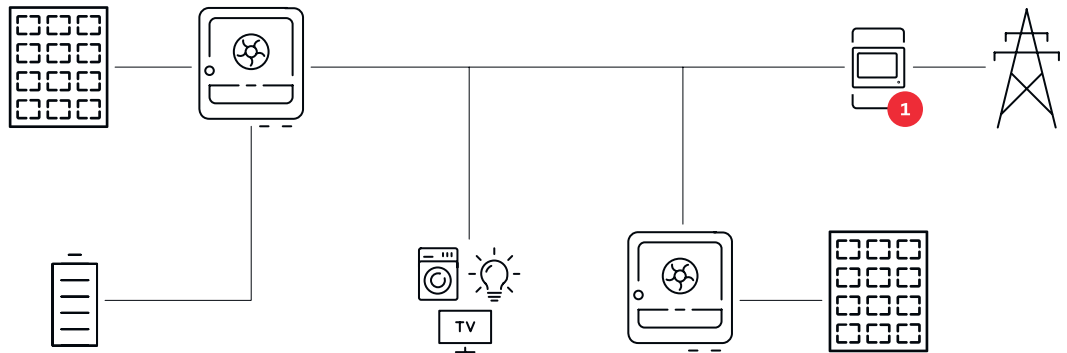

**Energy flow dir-
ection of the in-
verter**

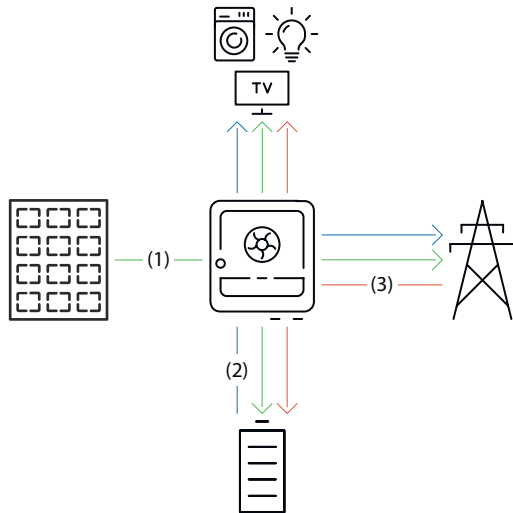

- (1) PV module - inverter - load/ grid/battery
- (2) Battery - inverter - load/grid*
- (3) Grid - inverter - load/battery*

* Charging the battery from the public grid depends on the settings and local standards and regulations.

**Operating states
(only for battery
systems)**

Battery systems distinguish between different operating states. In each case, the relevant current operating state is displayed on the user interface of the inverter or in Fronius Solar.web.

Operating state	Description
Normal operation	The energy is stored or drawn, as required.
Min. state of charge (SoC) reached	The battery has reached the minimum SoC specified by the manufacturer or the set minimum SoC. The battery cannot be discharged further.
Energy saving mode (standby)	The system has been put into energy-saving mode. Energy saving mode is automatically ended as soon as sufficient surplus power is available again.
Start	The battery system starts from energy-saving mode (standby).

Operating state	Description
Forced re-charging	The inverter recharges the battery, in order to maintain the SoC specified by the manufacturer or the set minimum SoC (protection against deep discharge).
Calibration charging	The battery system is charged to the SoC of 100% and then discharged to the SoC of 0%. After 1 hour of waiting time at SoC 0%, the calibration charge is stopped and the battery switches to normal operation.
Service mode	The battery system is charged or discharged to the SoC of 30% and the SoC of 30% is maintained until the end of the service mode.
Deactivated	The battery is not active. It has either been deactivated, switched off, or the communication between the battery and the inverter has been interrupted.

Energy-saving mode

General

Energy saving mode (standby mode) is used to reduce the self-consumption of the system. Both the inverter and the battery automatically switch to energy saving mode under certain conditions.

The inverter switches to energy saving mode if the battery is flat and no PV power is available. Only the inverter's communication with the Fronius Smart Meter and Fronius Solar.web is maintained.

Switch-off conditions

If all the switch-off conditions are met, the battery switches into energy saving mode within ten minutes. This time delay ensures that the inverter can at least be restarted.



≤ min. SoC

The battery state of charge is less than or equal to the input minimum state of charge.



< 100 W

The current charging or discharging power of the battery is less than 100 W.



< 50 W

Less than 50 W is available for charging the battery. The power of feeding into the public grid is at least 50 W less than the power currently required in the home network.

The inverter automatically switches into energy saving mode, following the battery.

Switch-on conditions

If one of the following conditions is met for at least 30 seconds, energy saving mode is ended:

- Energy saving mode is no longer permissible owing to a changed setting on the user interface of the inverter.
 - If dynamic power reduction of 0 is set, or if the system is operating in backup power mode, the power of feeding into the public grid is always less than the required power in the home network.
There is a separate condition for this case (dynamic power reduction < 300 W or active backup power mode):
 - If the PV power is above a specified threshold, energy saving mode is ended.
 - Battery charging from the public grid is requested via the user interface of the inverter.
 - The battery is being recharged in order to restore the minimum state of charge or perform calibration.
-

Special case

If the inverter does not operate for 12 minutes (e.g., fault), or there is an interruption in the electrical connection between the inverter and the battery and there is no backup power mode, the battery switches to energy-saving mode in any case. This reduces self discharge of the battery.

Indication of energy saving mode

During energy saving mode:

- Operating LED of the inverter lights up orange (see [Button functions and LED status indicator](#) on page 39).
- The user interface of the inverter can be reached.
- All the available data are saved and transmitted to Solar.web.
- The real-time data can be seen on Solar.web.

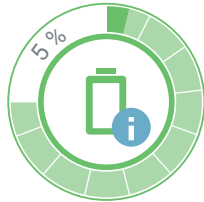

Energy saving mode is shown on the user interface of the inverter and in Solar.web by an "i" beside the battery symbol in the system overview.

Suitable batteries

General

Fronius explicitly points out that the third-party batteries are not Fronius products. Fronius is not the manufacturer, distributor, or retailer of these batteries. Fronius accepts no liability and offers no service or guarantees for these batteries.

Obsolete firmware/software states may lead to incompatibilities between the inverter and the battery. In this case, the following steps are to be performed:

- 1 Update battery software—see the battery documentation.
- 2 Update inverter firmware—see [Update](#) on page 108.

Read this document and the Installation Instructions before installing and commissioning the external battery. The documentation is either enclosed with the external battery or can be obtained from the battery manufacturer or their service partners

All documents associated with the inverter can be found at the following address:

<https://www.fronius.com/en/solar-energy/installers-partners/service-support/tech-support>

Fronius batteries

Fronius Reserva	
Capacity [kWh]	6.3 - 15.8
Number of modules	2 - 5
Fronius Symo GEN24 SC ¹⁾	✓
Fronius Symo GEN24 Plus SC	✓
Battery parallel operation ²⁾	✓

Fronius Reserva Pro	
Capacity [kWh]	12.0 - 32.0
Number of modules	3 - 8
Fronius Symo GEN24 SC ¹⁾	✓
Fronius Symo GEN24 Plus SC	✓
Battery parallel operation ²⁾	✓

1) Battery support optionally available.

2) Max. 4 batteries with the same capacity can be combined.

BYD batteries

BYD Battery-Box Premium HVS BYD Battery-Box HVS+	
Capacity [kWh] ¹⁾	5.1 - 12.8
Number of modules	2 - 5
Fronius Symo GEN24 SC ²⁾	✓
Fronius Symo GEN24 Plus SC	✓
Battery parallel operation ³⁾	✓

BYD Battery-Box Premium HVM BYD Battery-Box HVM+		
Capacity [kWh]	8.3	11.0 - 22.1
Number of modules	3	4 - 8
Fronius Symo GEN24 SC ²⁾	✗	✓
Fronius Symo GEN24 Plus SC	✗	✓
Battery parallel operation ³⁾	✗	✓

- 1) The capacity of 12.8 kWh is not approved and certified for Italy.
- 2) Battery support optionally available.
- 3) Max. 3 batteries with the same capacity can be combined. With BYD Battery-Box Premium HVM 22.1 max. 2 batteries can be combined.

IMPORTANT!

See the battery manufacturer's documentation for the maximum DC cable length.

IMPORTANT! The following switch-on sequence for the system must always be followed to ensure reliable operation with a BYD Battery-Box Premium.

1

Switch on the battery.

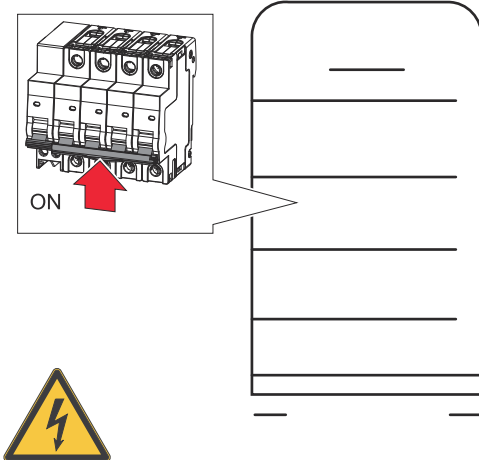

2

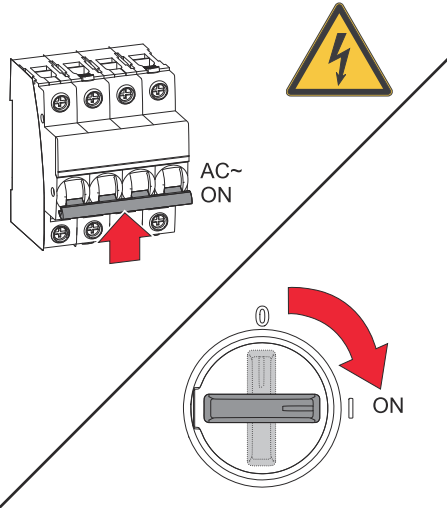

Turn on the automatic circuit breaker. Set the DC disconnect to the "on" switch position.

LG FLEX

LG FLEX	8.6	12.9	17.2
Number of battery modules	2	3	4
Fronius Symo GEN24 SC*	✓	✓	✓
Fronius Symo GEN24 Plus SC	✓	✓	✓

* Battery support optionally available.

Switching on the battery

1

Pull off the housing cover to the right.

2

Pull off the cover of the DC disconnect to the front.

3

Set the DC disconnect to the "on" switch position.

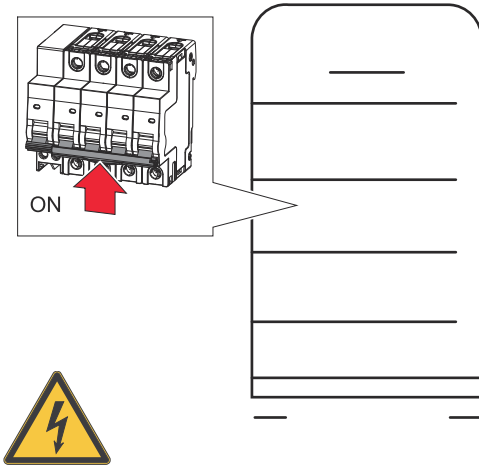

To assemble the battery, perform the steps listed above in reverse order.

Manual system start

Requirements

There is no energy available from the PV modules or from the public grid. If backup power operation or battery operation are not possible (e.g., deep discharge protection of the battery), the inverter and battery switch off.

Notification of system shutdown

Status codes about the inactive state of the battery are displayed on the user interface of the inverter. A notification via e-mail can be activated in Fronius Solar.web.

Manual battery start after system shutdown

As soon as energy is available again, the inverter starts operation automatically; however, the battery must be started manually. The switch-on sequence must be observed for this, see chapter [Suitable batteries](#) on page 31.

Starting backup power operation after a system shutdown

The inverter requires energy from the battery to start backup power operation. This is done manually on the battery; further information on the power supply for restarting the inverter via the battery can be found in the battery manufacturer's Operating Instructions.

Operating controls and connections

Connection area

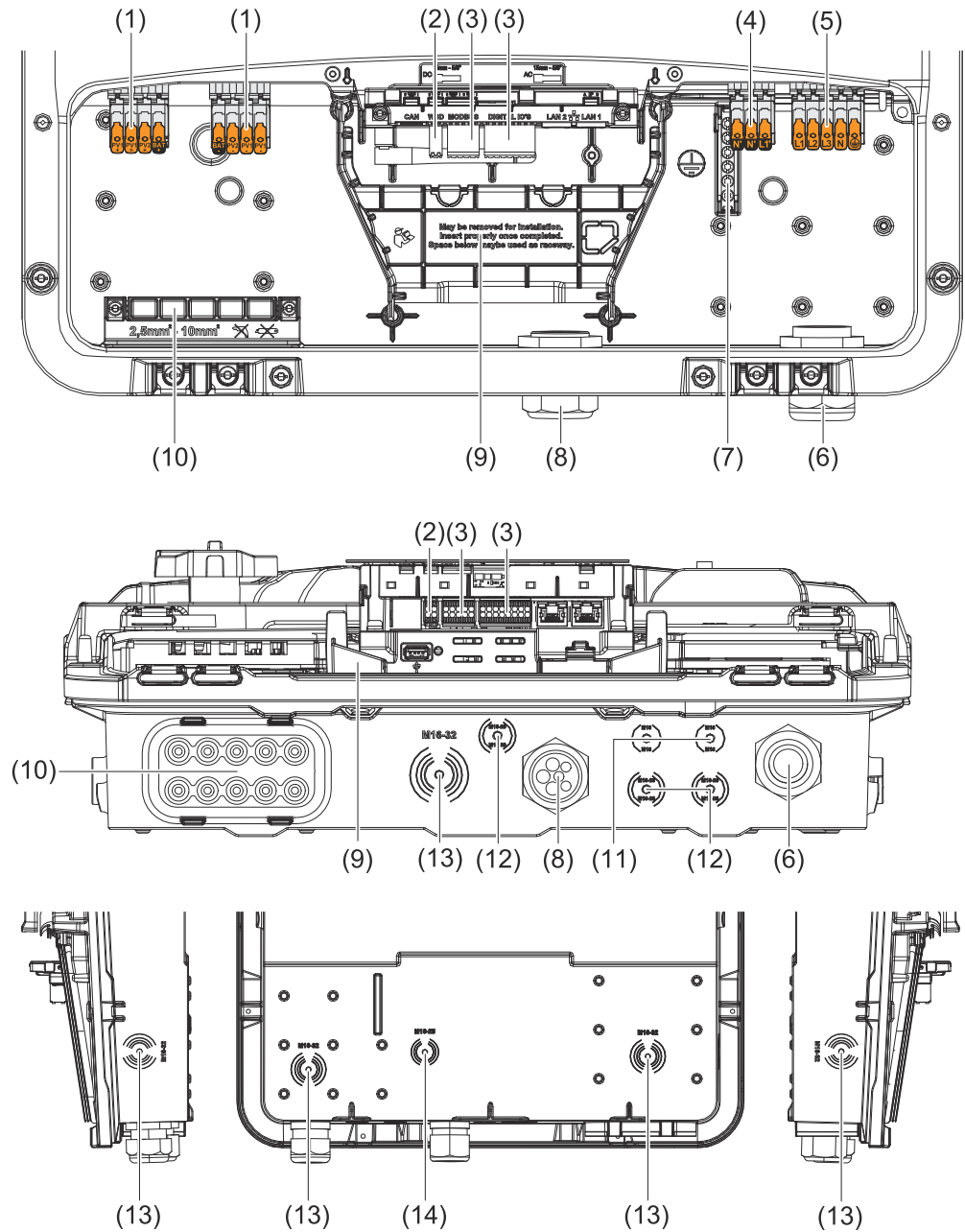

- (1) 2 x 4-pin DC push-in terminal
- (2) Push-in WSD (wired shutdown) terminal
- (3) Push-in terminals in the data communication area (Modbus, digital inputs and outputs)
- (4) 3-pin push-in terminal for PV Point (OP)
- (5) 5-pin AC push-in terminal
- (6) Cable gland/cable connection AC
- (7) 6-pin ground electrode terminal
- (8) Data communication area cable gland/cable connection
- (9) Connection area divider
- (10) 10 x DC glands

- (11) Optional cable gland (M16)
- (12) Optional cable gland (M16 - M20)
- (13) Optional cable gland (M16 - M32)
- (14) Optional cable gland (M16 - M25)

Connection area divider

The connection area divider separates the high-voltage conductors (DC and AC) from the signal lines. To make it easier to reach the connection area, the divider can be removed for the connection work, and must be re-inserted.

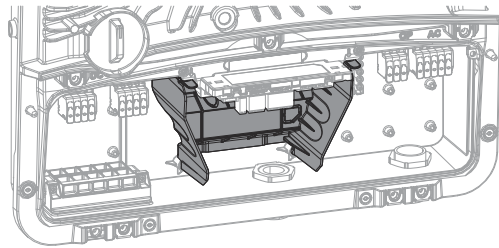

- (1) Integrated cable duct
- (2) Recesses for removing the connection area divider
- (3) Snap tabs for locking/unlocking
- (4) Defined breaking point for the DatCom connection

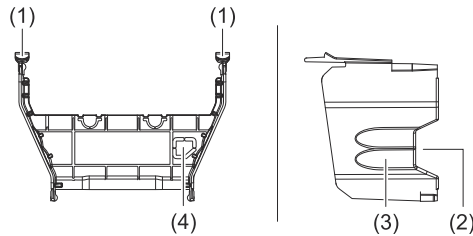

The integrated cable duct (1) allows for the lines to be laid from one area of the inverter to the other. As a result, multiple inverters can be easily installed next to each other.

Ground electrode terminal

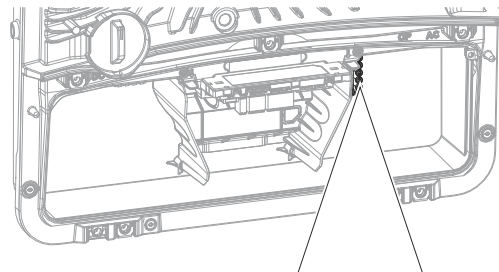

The ground electrode terminal \oplus provides the option of grounding additional components, such as:

- AC cable
- Module mounting system
- Ground spike

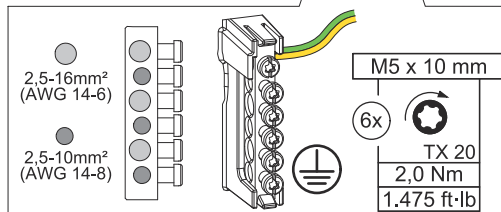

DC disconnect

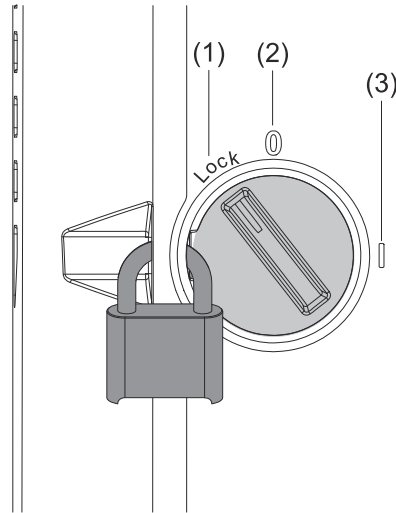

The DC disconnect has 3 switch settings:

- (1) Locked/off (turned to the left)
- (2) Off
- (3) On



IMPORTANT!

In switch settings (1) and (3), the inverter can be secured to prevent it from being switched on/off using a standard padlock. The national guidelines must be complied with in this respect.

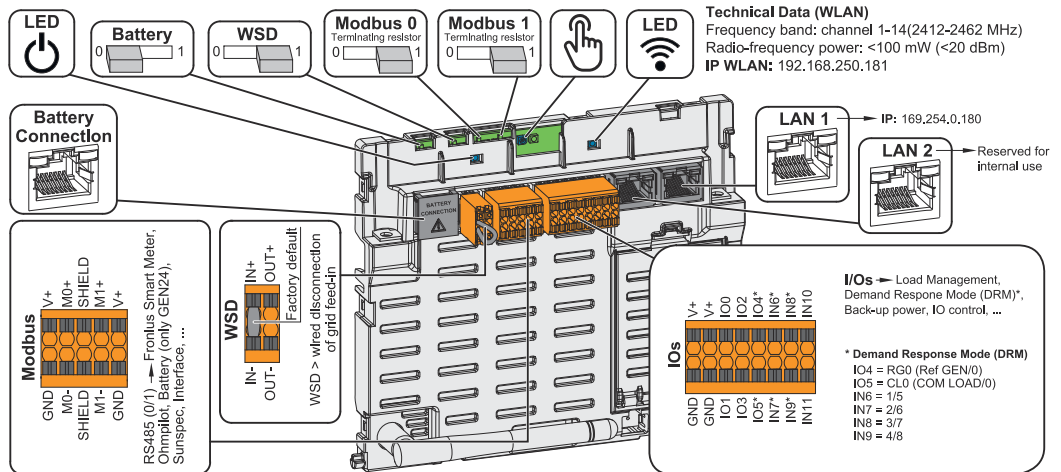
Data communication area



Operating LED	Indicates the inverter operating status.
BAT switch	Position 1: Setting for connecting compatible batteries (factory setting) Position 0: not in use
WSD (wired shutdown) switch	Defines the inverter as the WSD master or WSD slave. Position 1: WSD master Position 0: WSD slave
Modbus 0 (MBO) switch	Switches the terminating resistor for Modbus 0 (MBO) on/off. Position 1: Terminating resistor on (factory setting) Position 0: Terminating resistor off

Modbus 1 (MB1) switch	<p>Switches the terminating resistor for Modbus 1 (MB1) on/off.</p> <p>Position 1: Terminating resistor on (factory setting) Position 0: Terminating resistor off</p>
 Optical sensor	For operating the inverter. See Button functions and LED status indicator .
 Communications LED	Indicates the inverter connection status.
Battery Connection (Modbus RJ45)	<p>Modbus connection for connecting a compatible battery.</p> <p>IMPORTANT!</p> <ul style="list-style-type: none"> - This connection only works with hybrid inverters. - The connection is connected to Modbus 0. - Do not connect any network components (e.g., WiFi router) to this connection.
LAN 1	Ethernet connection for data communication (e.g., WiFi router, home network) or, for commissioning with a laptop, see Installation with the browser .
LAN 2	Reserved for future functions.
I/O terminal	<p>Push-in terminal for digital inputs/outputs. See Permitted cables for the data communication connection. The designations (RG0, CL0, 1/5, 2/6, 3/7, 4/8) relate to the Function Demand Response Mode, see Demand Response Modes (DRM).</p>
WSD terminal	Push-in terminal for the WSD installation. See WSD (wired shutdown) .
Modbus terminal	<p>Push-in terminal for the installation of Modbus 0, Modbus 1, 12 V, and GND (ground).</p> <p>The inverter establishes the data connection to the connected components via the Modbus terminal. The inputs M0 and M1 can be freely selected. Max. four Modbus participants per input, see Modbus participants.</p>

Button functions and LED status indicator

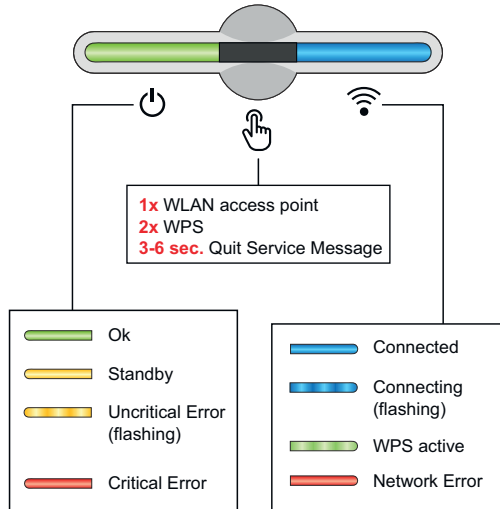

The operating status LED displays the status of the inverter. In case of faults, follow the individual steps in the Fronius Solar.start app.



The optical sensor is actuated by touching it with a finger.



The communications LED displays the connection status. To establish a connection, follow the individual steps in the Fronius Solar.start app.

Sensor functions

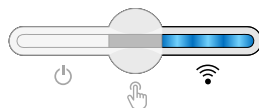

1x = WLAN access point (AP) is opened.

Flashes blue

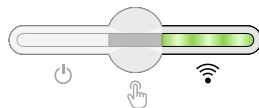

2x = WLAN protected setup (WPS) is activated.

Flashes green

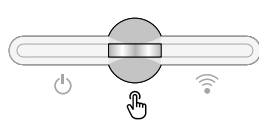

3 seconds (max. 6 seconds) = The service message disappears.

Flashes white (quickly)

LED status indicator

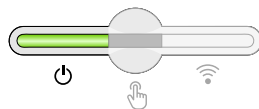

The inverter is operating correctly.

Lights up green

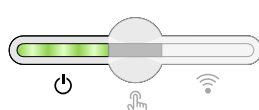

The inverter is performing the grid checks required by the applicable standards for grid power feed operation.

Flashes green

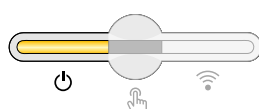

The inverter is on standby, is not operating (e.g., no energy fed into the grid at night), or is not configured.

Lights up yellow

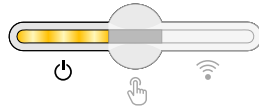

The inverter displays a non-critical status.

Flashes yellow

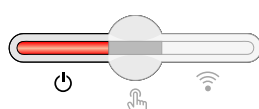

The inverter displays a critical status and no energy is fed into the grid.

Lights up red

LED status indicator

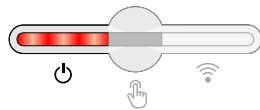

The inverter displays a backup power overload.

⏻ Flashes red

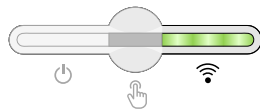

The network connection is being established via WPS.
2x 🖱 = WPS search mode.

📶 Flashes green

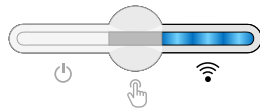

The network connection is being established via WLAN AP.
1x 🖱 = WLAN AP search mode (active for 30 minutes).

📶 Flashes blue

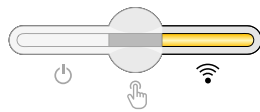

The network connection is not configured.

📶 Lights up yellow

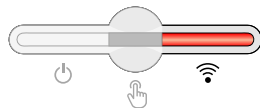

A network error is displayed, the inverter is operating correctly.

📶 Lights up red

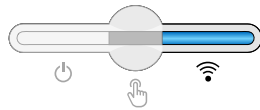

The network connection is active.

📶 Lights up blue

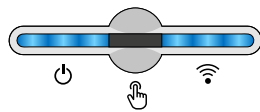

The inverter is performing an update.

⏻ / 📶 Flash blue

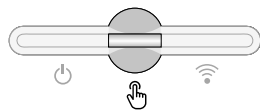

There is a service message.

🖱 Lights up white

Schematic internal wiring of IOs

The V+/ GND pin provides the possibility of feeding in a voltage in the range of 12.5 to 24 V (+ max. 20%) using an external power supply unit. Outputs IO 0 - 5 can then be operated using the external voltage that has been fed in. A maximum of 1 A may be drawn per output, whereby a total of max. 3 A is permitted. The fuse protection must take place externally.

⚠ CAUTION!

Danger from polarity reversal at the terminals due to improper connection of external power supply units.

This may result in severe damage to the inverter.

- ▶ Check the polarity of the external power supply unit with a suitable measuring device before connecting it.
- ▶ Connect the cables to the V+/GND outputs while ensuring the correct polarity.

IMPORTANT!

If the total output (6 W) is exceeded, the inverter switches off the entire external power supply.

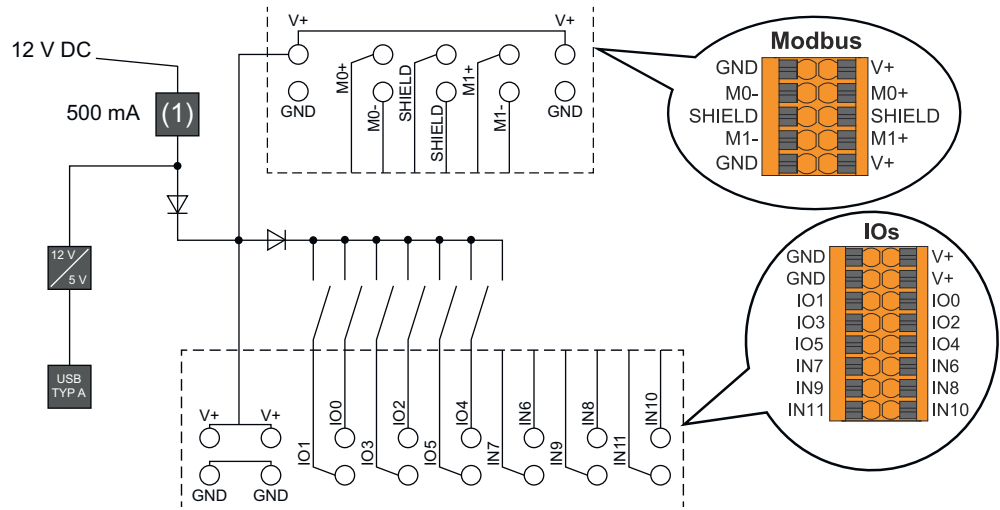

(1) Current limitation

Backup power variant - PV Point (OP)

General

Explanatory note - PV Point/PV Point Comfort

IMPORTANT!

If several backup power variants are available, please note that only one backup power variant may be installed and configured.

The inverter can provide 220-240 V at the PV Point/PV Point Comfort. A corresponding configuration must be set up during commissioning.

At 220-240 V output voltage, max. 13 A AC continuous current is available.

Example:

220 V *13 A = 2,860 W

230 V *13 A = max. 3 kW

In backup power mode, some electrical appliances cannot function properly as starting currents are too high (for example, fridges and freezers). It is recommended to switch off non-essential loads during backup power mode. Overload capacity of 35% is possible for a duration of 5 seconds, depending on the capacity of the PV modules and/or the battery at that moment in time.

There is a brief interruption when switching from grid-connected mode to backup power mode. For this reason, the backup power function cannot be used as an uninterruptible power supply, for example for computers.

If no energy from the battery or the PV modules is available in backup power mode, backup power mode ends automatically. If sufficient energy becomes available from the PV modules once again, backup power mode starts again automatically.

In the event of excessive consumption, backup power mode is stopped and the "backup power overload" status code is displayed on the inverter's LED status indicator (see [Button functions and LED status indicator](#) on page 39). The maximum power in backup power mode according to the technical data must be observed.

PV Point (OP)

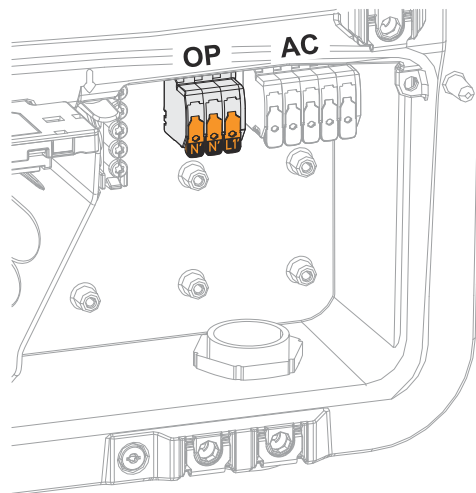

With the PV Point, in the event of a failure of the public grid, 1-phase electrical devices can be connected to the Opportunity Power (OP) terminal and supplied with a maximum power of 3 kW, if enough power is available in the solar modules or an optional battery. In grid connected operation, the OP terminal is not supplied with voltage, therefore the connected loads will not be permanently supplied with power.

IMPORTANT!

A grid switchover with relay is not possible.

For the installation instructions, see chapter [Connecting backup power - PV Point \(OP\)](#) on page 75.

PV Point Comfort

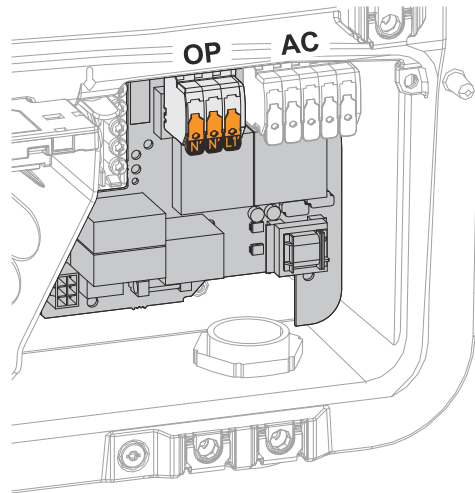

With the PV Point Comfort, 1-phase electrical devices are permanently supplied with a maximum power of 3 kW.

Switching between grid connected and backup power mode takes place automatically. In the event of a failure of the public grid or the inverter, the PV Point Comfort permanently supplies connected loads. When the grid becomes available again and stability is ensured, the PV Point Comfort automatically switches to grid connected mode and backup power mode is terminated.

IMPORTANT!

Backup power mode requires sufficient power from the PV modules or a battery. The PV Point Comfort is not available in Australia and New Zealand.

For further information and the installation instructions, see chapter [PV Point Comfort](#) on page 154.

Installation

General

Quick-fastener system

NOTE!

Danger when using a drill driver.

This may result in the destruction of the quick-fastener system due to over-torque.

- ▶ Use a screwdriver (TX20).
- ▶ Do not turn the screws more than 180°.

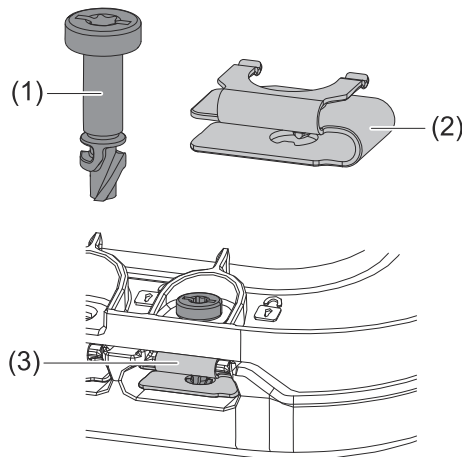

A quick-fastener system (3) is used to mount the connection area cover and front cover. The system is opened and closed with a half-rotation (180°) of the captive screw (1) into the quick-fastener spring (2).

The system is independent of torque.

System component compatibility

All installed components in the PV system must be compatible with each other and have the necessary configuration options. The installed components must not restrict or negatively affect the functioning of the PV system.

NOTE!

Risk due to components in the PV system that are not and/or only partially compatible.

Incompatible components can restrict and/or negatively affect the operation and/or functioning of the PV system.

- ▶ Only install components recommended by the manufacturer in the PV system.
- ▶ Before installation, check the compatibility of components that have not been expressly recommended with the manufacturer.

Installation location and position

Choosing the location of the inverter

Please observe the following criteria when choosing a location for the inverter:

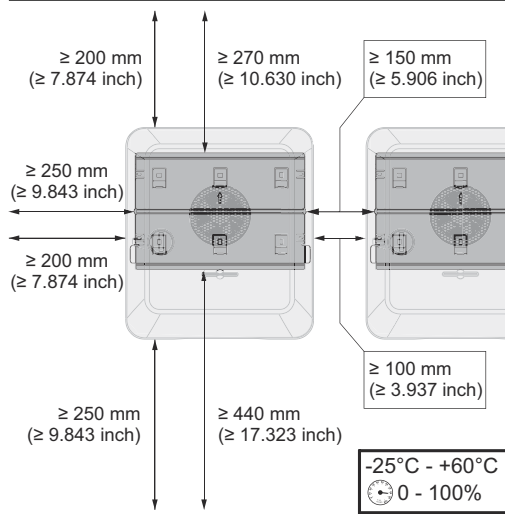

Only install on a solid, non-flammable surface.

Max. ambient temperatures:
-25 °C - +60 °C

Relative humidity:
0-100%

When installing the inverter in a switch cabinet or similar closed environment, it is necessary to make sure that the hot air that develops will be dissipated by forced-air ventilation.

For more detailed information on inverter dimensions, see chapter [Dimensions of the inverter](#) on page 203.

When installing the inverter on the outer walls of cattle sheds, it is important to maintain a minimum clearance of 2 m between all sides of the inverter and the ventilation and building openings.

The following substrates are permissible for installation:

- Walls (corrugated metal walls [mounting rails], brick walls, concrete walls, or other non-flammable surfaces sufficiently capable of bearing loads)
- Mast or beam (installed using mounting rails, behind the PV modules directly on the PV mounting system)
- Flat roofs (if this is for a film roof, make sure that the films comply with the fire protection requirements and are not highly flammable. Ensure compliance with the national provisions.)
- Covered parking lot roofs (no overhead installation)



The inverter is suitable for indoor installation.



The inverter is suitable for outdoor installation.

Because of its IP 66 protection class, the inverter is not susceptible to water spray from any direction and can also be operated in moist environments.

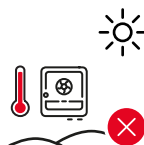

In order to keep inverter heating as low as possible, do not expose the inverter to direct sunlight.



The inverter should be installed in a protected location, e.g., near the PV modules or under an overhanging roof.

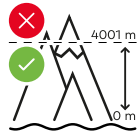

The inverter must not be installed or operated at more than 4,000 m above sea level.



Do not install the inverter:

- Where it may be exposed to ammonia, corrosive gases, acids, or salts (e.g., fertilizer storage areas, vent openings for livestock stables, chemical plants, tanneries)



During certain operating phases the inverter may produce a slight noise. For this reason it should not be installed in an occupied living area.



Do not install the inverter in:

- Areas where there is an increased risk of accidents from farm animals (e.g., horses, cattle, sheep, pigs)
- Stables or adjoining areas
- Storage areas for hay, straw, chaff, animal feed, and fertilizers



The inverter is designed to be dust-proof (IP 66). In areas of high dust accumulation, dust deposits may collect on the cooling surfaces, and thus impair the thermal performance. Regular cleaning is required in this case, see chapter [Operation in dusty environments](#) on page 167. We therefore recommend not installing the inverter in areas and environments with high dust accumulation.



Do not install the inverter in:

- Greenhouses
- Storage or processing areas for fruit, vegetables, or viticulture products
- Areas used in the preparation of grain, green fodder, or animal feeds

Choosing the location of third-party batteries

IMPORTANT!

Refer to the manufacturer's documents for specifications regarding the suitable location of third-party batteries.

Installation position of the inverter



The inverter is suitable for vertical installation on a vertical wall or column.

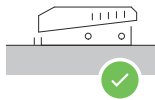
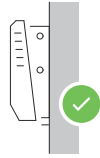

The inverter is suitable for a horizontal installation position.

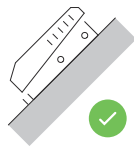

The inverter is suitable for installation on a sloping surface.

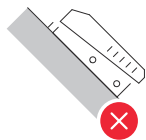

Do not install the inverter on a sloping surface with the connections upwards.



Do not install the inverter in a sloping position on a vertical wall or column.



Do not install the inverter in a horizontal position on a vertical wall or column.



Do not install the inverter with the connections upwards on a vertical wall or column.

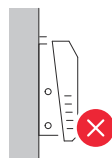

Do not install the inverter overhanging with the connections upwards.

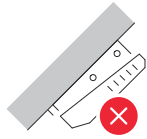

Do not install the inverter overhanging with the connections downwards.

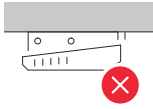

Do not install the inverter on the ceiling.

Installing the mounting bracket and attaching the inverter

Selecting the mounting material

Use the corresponding fixing materials depending on the subsurface and observe the screw dimension recommendations for the mounting bracket. The installer is responsible for selecting the right type of fixing.

Properties of the mounting bracket

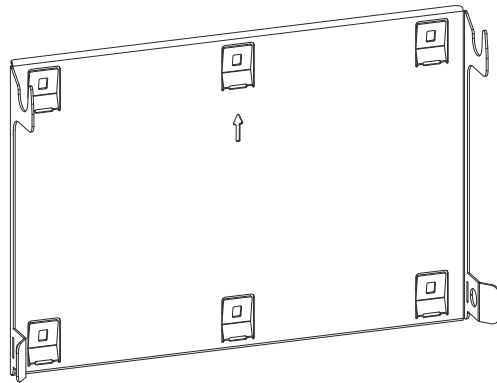

The mounting bracket (illustration) can also be used as a gauge.

The pre-drilled holes on the mounting bracket are intended for screws with a thread diameter of 6 - 8 mm (0.24 - 0.32 inches).

Unevenness on the mounting surface (such as coarse-textured plaster) is largely compensated by the mounting bracket.

Do not deform the mounting bracket

NOTE!

When attaching the mounting bracket to the wall or to a column, make sure that the mounting bracket is not deformed.

A deformed mounting bracket may make it difficult to clip/swivel the inverter into position.

Fitting the mounting bracket to a wall

IMPORTANT!

Fit the mounting bracket with the arrow pointing upwards.

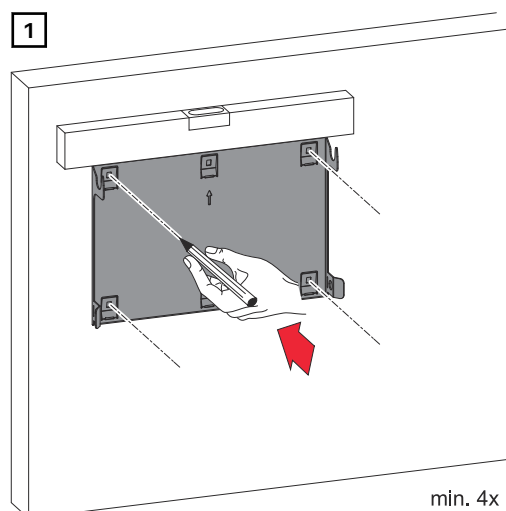

Align the mounting bracket and mark the drill holes.

2

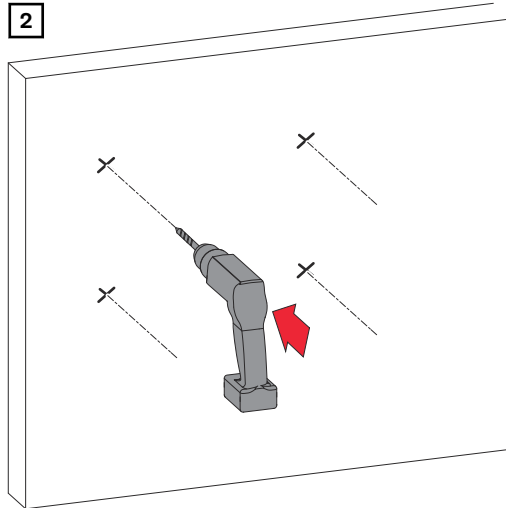

Drill the drill holes.

3

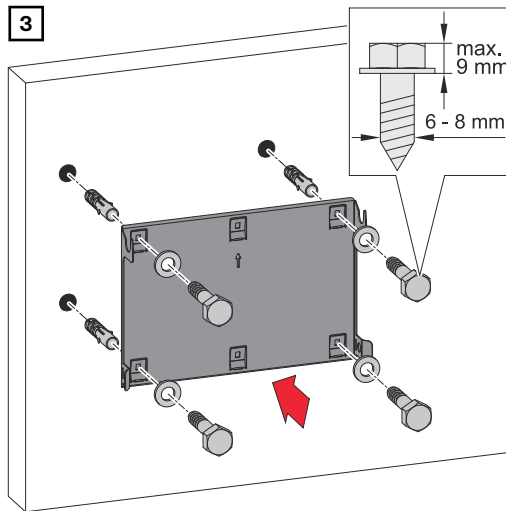

Insert dowels and fasten the mounting bracket to the wall with 4 screws.

Installing the mounting bracket on a mast or beam

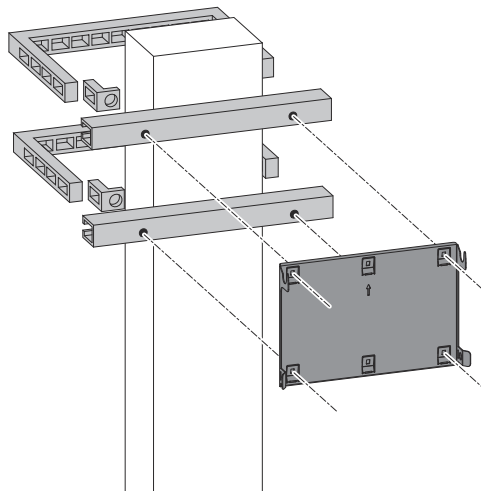

When installing the inverter on a mast or beam, Fronius recommends using the "Pole clamp" (order no. SZ 2584.000) mounting kit from Rittal GmbH.

The "Pole clamp" kit covers the following dimensions:

- Rectangular mast or beam with a side length of 50-150 mm (1.97-5.91 inches)
- Round mast or beam with a diameter of 40-190 mm (1.57-7.48 inches)

Attaching the mounting bracket to mounting rails

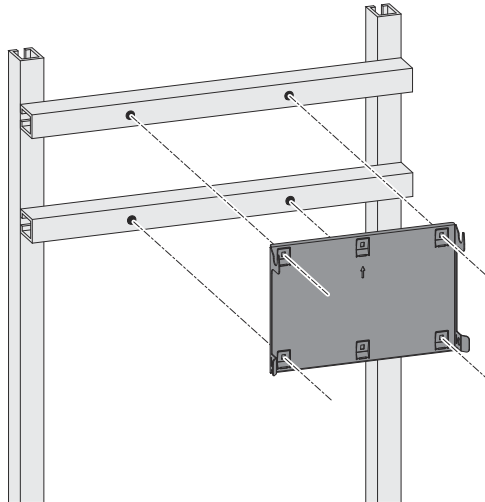

IMPORTANT!

The mounting bracket must be affixed at a minimum of four points.

Attaching the inverter to the mounting bracket

1

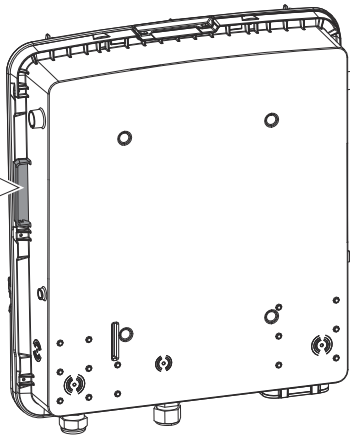
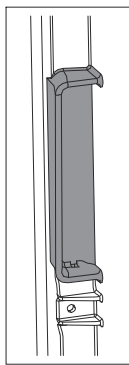

Lift the inverter by the integrated side handles.

2

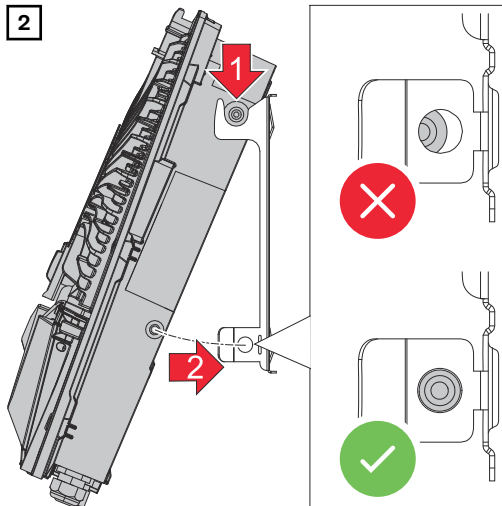

Clip the inverter into the mounting bracket from above. The connections must point downwards.

Press the lower area of the inverter into the snap-in tabs on the mounting bracket until the inverter engages on both sides with an audible click.

3

Check that the inverter is correctly in position on both sides.

Requirements for connecting the inverter

Different cable types

Single-core	Multi-stranded	Fine-stranded	Fine-stranded with ferule and collar	Fine-stranded with ferule without collar
				

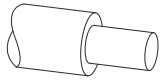
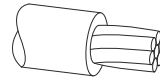
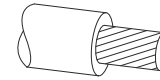
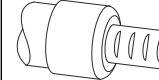
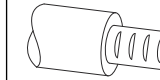

Permissible cables for the electrical con-

Round copper conductors can be connected to the terminals of the inverter as described below.

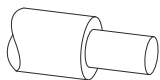
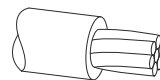
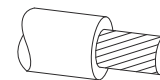
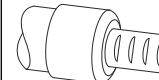
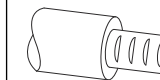
Grid connections with push-in terminal* Select a sufficiently large cable cross-section based on the actual device output.					
Number of pins					
5	1.5-10 mm ²	1.5-10 mm ²	1.5-10 mm ²	1.5-6 mm ²	1.5-6 mm ²

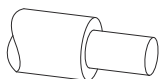
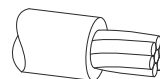
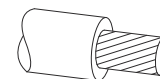
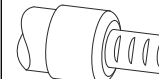
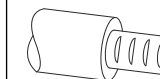
Grid connections backup power with push-in terminal* Select a sufficiently large cable cross-section based on the actual device output.					
Number of pins					
3	1.5-10 mm ²	1.5-10 mm ²	1.5-10 mm ²	1.5-6 mm ²	1.5-6 mm ²

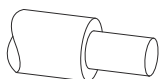
PV/BAT connections with push-in terminal** Select a sufficiently large cable cross-section based on the actual device output.					
Number of pins					
2 x 4	4-10 mm ²	4-10 mm ²	4-10 mm ²	4-6 mm ²	4-6 mm ²

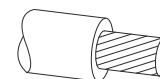
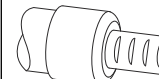
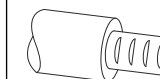
Ground electrode terminal Select a sufficiently large cable cross-section based on the actual device output.					
Number of pins					
2	1.5-16 mm ²	1.5-16 mm ²	1.5-16 mm ²	1.5-16 mm ²	1.5-16 mm ²
4	1.5-10 mm ²	1.5-10 mm ²	1.5-10 mm ²	1.5-10 mm ²	1.5-10 mm ²

* According to product standard IEC 62109, the ground conductor must correspond to the phase cross-section for phase cross-sections ≤16 mm², while for phase cross-sections >16 mm², it must be at least 16 mm².

For a conductor cross-section of 1.5 mm², the maximum permissible cable length is 100 m.

** The cable cross-section must be dimensioned in accordance with the installation situation and the specifications of the battery manufacturer.



Permitted cables for the data communication connection



Cables with the following design can be connected to the terminals of the inverter:

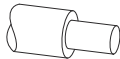
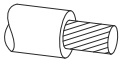

- Copper: round, solid
- Copper: round, fine-stranded

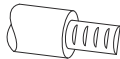
IMPORTANT!

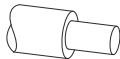
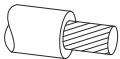
If several single conductors are connected to an input of the push-in terminal, connect the single conductors with a corresponding ferrule.

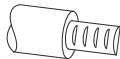
WSD connections with push-in terminal						
Distance	Stripping length					Cable recommendation
100 m 109 yd	10 mm 0.39 inch	0.14-1.5 mm ² AWG 26-16	0.14-1.5 mm ² AWG 26-16	0.14-1 mm ² AWG 26-18	0.14 -1.5 mm ² AWG 26-16	Min. CAT 5 UTP (unshielded twisted pair)

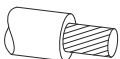
Modbus connections with push-in terminal						
Distance	Stripping length					Cable recommendation
300 m 328 yd	10 mm 0.39 inch	0.14-1.5 mm ² AWG 26-16	0.14-1.5 mm ² AWG 26-16	0.14-1 mm ² AWG 26-18	0.14-1.5 mm ² AWG 26-16	Min. CAT 5 STP (shielded twisted pair)

IO connections with push-in terminal						
Distance	Stripping length					Cable recommendation
30 m 32 yd	10 mm 0.39 inch	0.14-1.5 mm ² AWG 26-16	0.14-1.5 mm ² AWG 26-16	0.14-1 mm ² AWG 26-18	0.14-1.5 mm ² AWG 26-16	Single conductors possible

LAN connections
Fronius recommends using at least CAT 5 STP (shielded twisted pair) cables and a maximum distance of 100 m (109 yd).

Cable diameter of the AC cable

For a standard M32 cable gland **with a reducer:**
7-15 mm

For a standard M32 cable gland **without a reducer**:

11-21 mm

(with a cable diameter of less than 11 mm, the strain-relief force is reduced from 100 N to a maximum of 80 N)

With cable diameters greater than 21 mm, the M32 cable gland must be replaced by an M32 cable gland with a larger clamping area—item number: 42,0407,0780—strain-relief device M32 x 1.5 KB 18-25.

Cable diameter of the DC cable

Cable diameter for the strain-relief device: max. 9 mm.

Cable diameter for the connection to the push-in terminal: max. 6 mm

IMPORTANT!

For double-insulated cables with a cable diameter over 6 mm, the external insulation layer must be removed to connect to the push-in terminal.

Maximum alternating current fuse protection

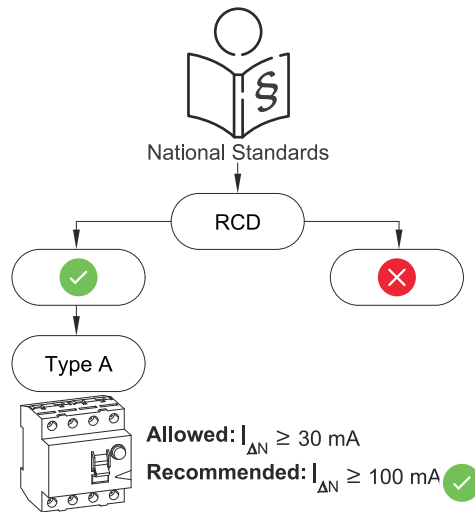

NOTE!

A residual current circuit breaker for the AC connecting cable may be required depending on national regulations, the grid operator, and other conditions.

A type A residual current circuit breaker is generally sufficient in this case. Nevertheless, type A residual current circuit breakers may trip erroneously in individual cases and under certain local circumstances. For this reason, Fronius recommends using a residual current circuit breaker suitable for frequency inverters with a tripping current of at least 100 mA (national provisions must be taken into account).

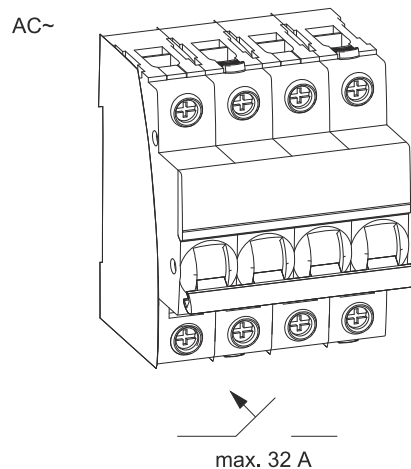

IMPORTANT!

The inverter may be used with a 32 A automatic circuit breaker as a maximum.

Inverter	Phase s	AC power	Maximum fuse pro- tection	Recom- mended fuse pro- tection
Fronius Symo GEN24 3 kW SC	3	3000 W	32 A	10 A
Fronius Symo GEN24 4 kW SC	3	4000 W	32 A	13 A
Fronius Symo GEN24 5 kW SC	3	5000 W	32 A	16 A

Connecting the inverter to the public grid (AC side)

Safety

WARNING!

Danger from incorrect operation and work that is not carried out properly.

This can result in severe personal injury and damage to property.

- ▶ Read the Installation Instructions and Operating Instructions before installing and commissioning the equipment.
- ▶ Only qualified personnel are authorized to commission the inverter and only within the scope of the respective technical regulations.

WARNING!

Danger from grid voltage and DC voltage from PV modules that are exposed to light.

An electric shock can be fatal.

- ▶ Prior to any connection work, ensure that the inverter is de-energized on the AC side and the DC side.
- ▶ Only an authorized electrical engineer is permitted to connect this equipment to the public grid.

WARNING!

Danger from damaged and/or contaminated terminals.

This can result in severe personal injury and damage to property.

- ▶ Prior to connection work, check the terminals for damage and contamination.
- ▶ Remove any contamination while the equipment is de-energized.
- ▶ Have defective terminals replaced by an authorized specialist.

Connecting the inverter to the public grid (AC side)

CAUTION!

Danger due to incorrect connection of the inverter.

This may result in severe damage to the inverter.

- ▶ It is not possible to operate the inverter in ungrounded grids, e.g., IT grids (insulated grids without ground conductor).
- ▶ The neutral conductor must be connected in order to operate the inverter.
- ▶ Make sure that the grid's neutral conductor is grounded.

1

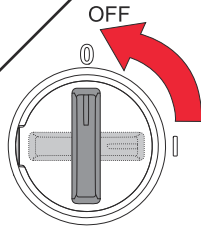
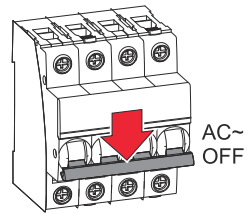

Turn off the automatic circuit breaker. Set the DC disconnect to the "off" switch position.

2

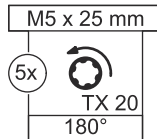
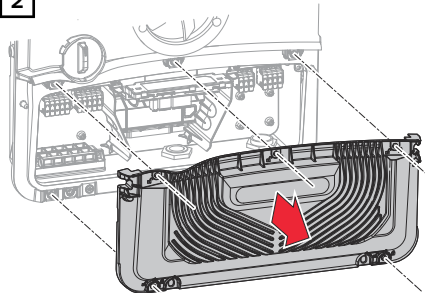

Loosen the 5 screws on the connection area cover by rotating them 180° to the left using a screwdriver (TX20). Remove the connection area cover from the device.

3

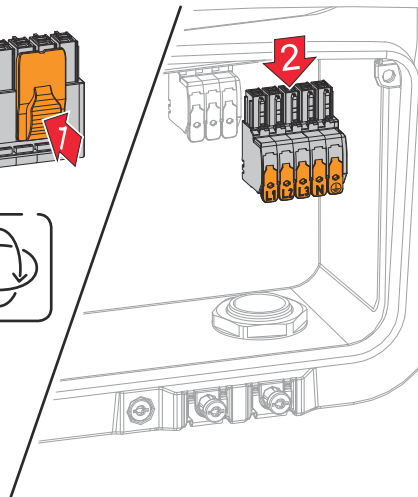
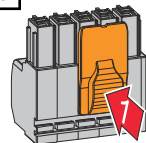

Press the latch on the back of the terminal and remove the AC terminal.

4

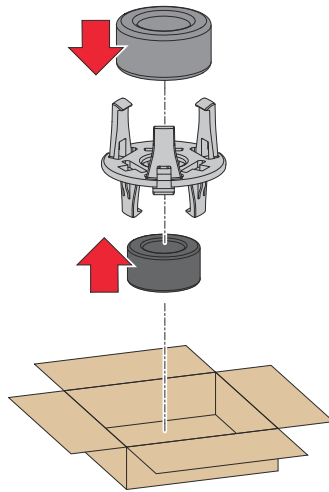

Insert the ferrite rings supplied into the holder.

5

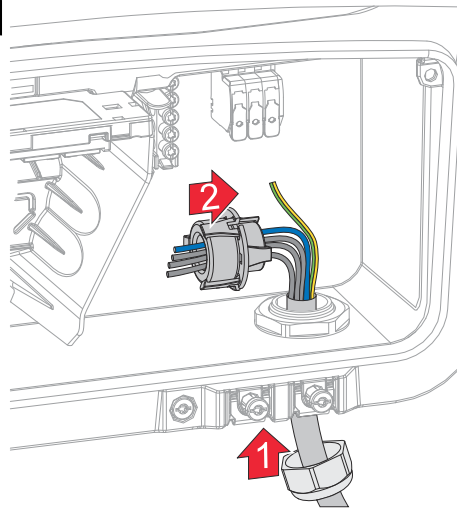

Guide the mains cable from below through the cable gland on the right side and the ferrite core.

IMPORTANT!

The ground conductor must not be fed through the ferrite core. Dimension the ground conductor longer and lay it with a movement loop so that it will be the last conductor subjected to mechanical stress in the event of a cable gland failure.

For more information about the cable gland, see chapter [Cable diameter of the AC cable](#) on page 58.

6

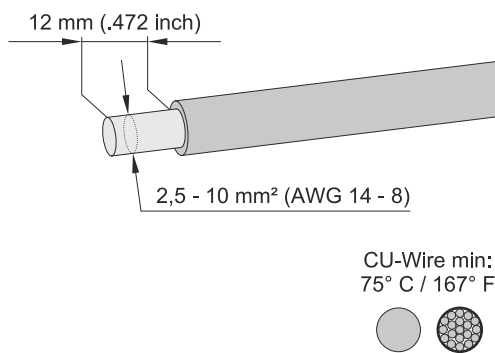

Select the cable cross-section in accordance with chapter [Permissible cables for the electrical connection](#) on page 57.

Strip 12 mm of insulation from the single conductors.

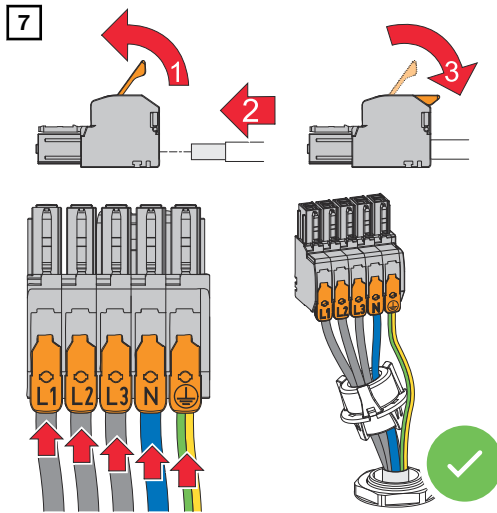

Lift the operating lever of the terminal to open. Insert the stripped single conductor into the slot provided in the terminal as far as it will go. Then close the operating lever until it engages.

IMPORTANT!

Only one conductor may be connected to each pin. The AC cables can be connected to the AC terminal without ferrules.

- L1 Phase conductor
- L2 Phase conductor
- L3 Phase conductor
- N Neutral conductor
- PE Ground conductor

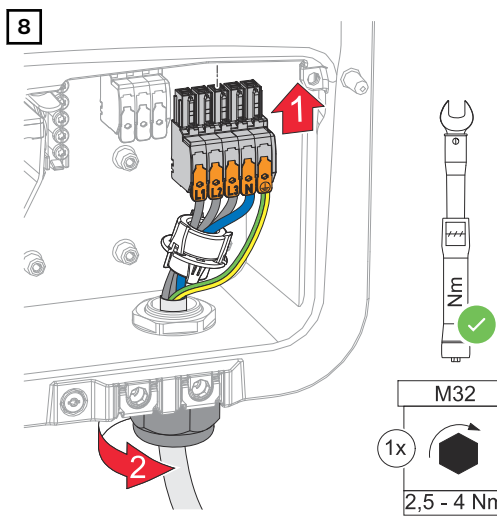

Insert the AC terminal into the AC slot until it engages. Fasten the union nut of the cable gland with a torque of 6 - 7 Nm.

Connecting solar module strings to the inverter

General information about PV modules

To enable suitable PV modules to be chosen and to use the inverter as efficiently as possible, it is important to bear the following points in mind:

- If insolation is constant and the temperature is falling, the open circuit voltage of the PV modules will increase. The open circuit voltage must not exceed the max. permissible system voltage. An open circuit voltage above the indicated values will damage the inverter, and all warranty rights will become null and void.
- The temperature coefficients on the data sheet of the PV modules must be observed.
- Exact values for sizing the PV modules can be obtained using suitable calculation tools, such as the [Fronius Solar.creator](#).

IMPORTANT!

Before connecting up the PV modules, check that the voltage for the PV modules specified by the manufacturer corresponds to the actual measured voltage.

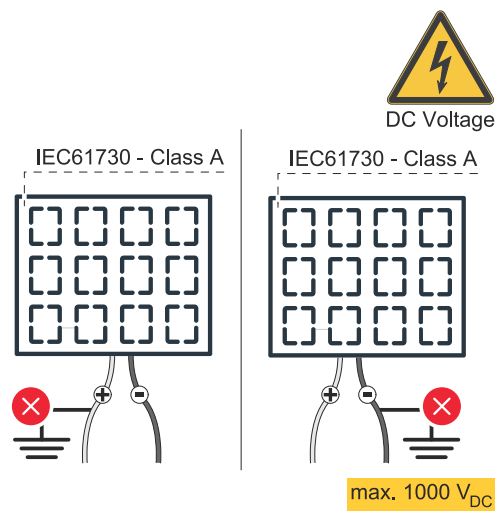

IMPORTANT!

The PV modules connected to the inverter must comply with the IEC 61730 Class A standard.

IMPORTANT!

Solar module strings must not be grounded.

Safety



WARNING!

Danger from incorrect operation and work that is not carried out properly.

This can result in severe personal injury and damage to property.

- ▶ The commissioning, maintenance, and service work in the inverter's power stage set may only be carried out by Fronius-trained service personnel in accordance with the technical specifications.
- ▶ Read the installation instructions and operating instructions before installing and commissioning the equipment.

⚠ WARNING!

Danger from mains voltage and DC voltage from PV modules that are exposed to light.

This can result in severe personal injury and damage to property.

- ▶ All connection, maintenance, and service work should only be carried out when the AC and DC sides have been disconnected from the inverter and are de-energized.
- ▶ Only an authorized electrical engineer is permitted to connect this equipment to the public grid.

⚠ WARNING!

Danger of an electric shock due to improperly connected terminals/PV plug connectors.

An electric shock can be fatal.

- ▶ When connecting, ensure that each pole of a string is routed via the same PV input, e.g.:
+ pole string 1 to the input **PV 1.1+** and **- pole string 1** to the input **PV 1.1-**

⚠ WARNING!

Danger from damaged and/or contaminated terminals.

This can result in severe personal injury and damage to property.

- ▶ Prior to connection work, check the terminals for damage and contamination.
- ▶ Remove any contamination while the equipment is de-energized.
- ▶ Have defective terminals replaced by an authorized specialist company.

PV Generator, general

Two independent PV inputs (PV 1 and PV 2) are available. These inputs can be connected to a different number of modules.

When starting for the first time, set up the PV Generator in accordance with the respective configuration (can also be carried out at a later date in the **Device Configuration > Components** menu area).

Module array configuration

IMPORTANT!

Carry out the installation in accordance with the nationally applicable standards and guidelines. If the Arc Fault Circuit Interrupter integrated in the inverter is being used for arc detection according to IEC 63027, the solar module strings must not be combined upstream of the inverter.

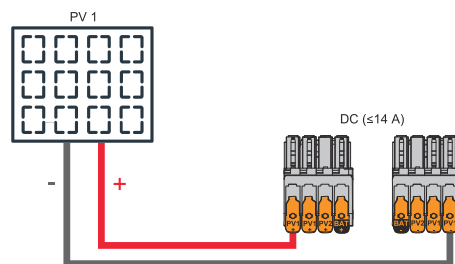

Module array settings:

PV 1: **ON**

PV 2: **OFF**

Current less than or equal to 14 A (I_{dcmax}).

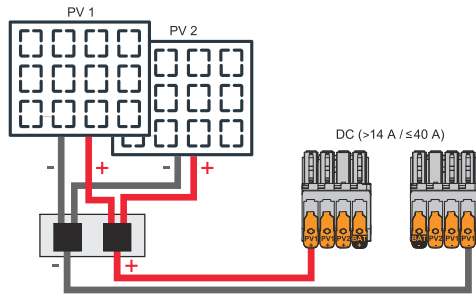

Combined solar module strings with total current greater than 14 A (I_{dcmax}).

Module array settings:

PV 1: **ON**

PV 2: **OFF**

PV 1 + PV 2 (connected in parallel): **ON**

IMPORTANT!

It is permitted to split the total current (I_{dcmax}) by bridging from PV 1 to PV 2 at the terminal up to ≤ 40 A (I_{SCmax}).

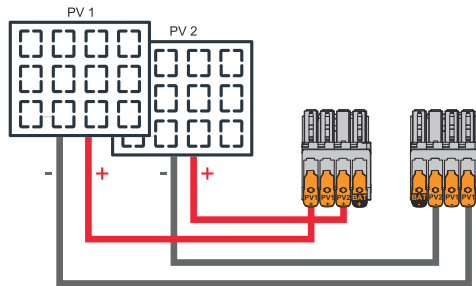

PV 1 less than or equal to 20 A ($I_{SC PV1}$)
PV 2 less than or equal to 20 A ($I_{SC PV2}$)

Module array settings:

PV 1: **ON**

PV 2: **ON**

Connecting solar module strings to the inverter

1

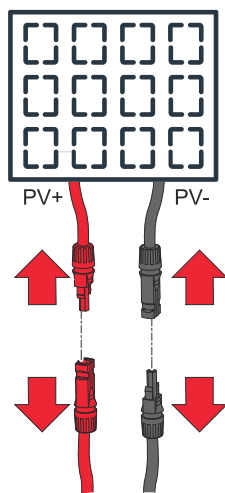

Disconnect connections from the solar module strings (+/-).

max. 1000 V_{DC}

2

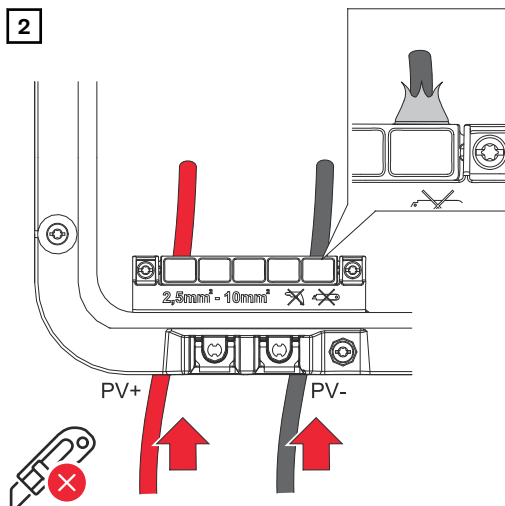

Push the DC cables through the DC bushings by hand.

IMPORTANT!

Push the cables through the DC bushings before stripping them. This avoids twisting/bending single wires.

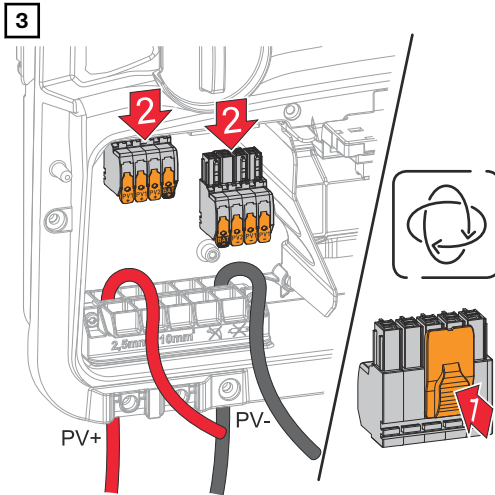

Remove the DC push-in terminals from the slots.

For measurements on the DC cables, use the Fronius Inspection Kit (44,0240,0004) or an adapter cable with a suitable DC plug (e.g., MC4). Connect the adapter cable to the DC push-in terminals and place the DC plug outside the inverter.

⚠ WARNING!

Danger from loose and/or incorrectly clamped single conductors in the terminal.

This can result in serious injury and damage to property.

- ▶ Only connect one single conductor in the slot provided for each terminal.
- ▶ Check that the single conductors are secure in the terminal.
- ▶ Make sure that the single conductor has been fully inserted into the terminal and that no single wires are protruding out of the terminal.

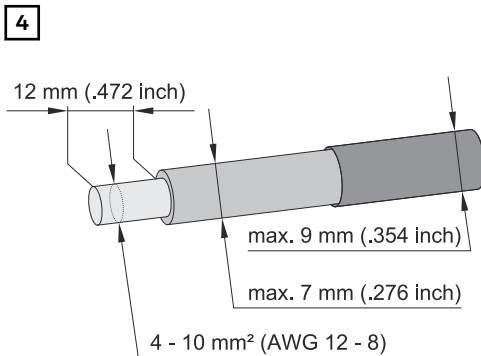

Select the cable cross-section in accordance with the instructions in [Permissible cables for the electrical connection](#) from page 57. Strip the insulation of the single conductors by 12 mm.

CU-Wire min:
75° C / 167° F

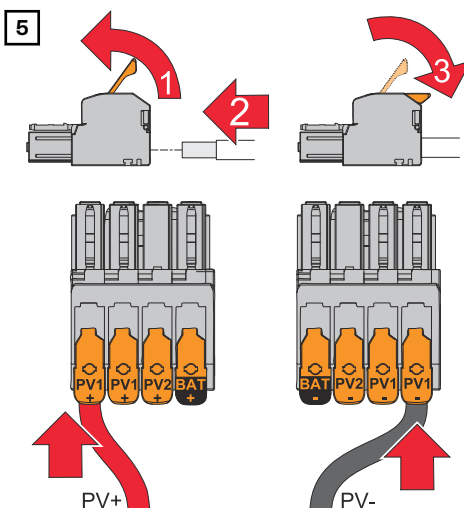
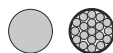

Lift the operating lever of the terminal to open. Insert the stripped single conductor into the slot provided in the terminal as far as it will go. Then close the operating lever until it engages.

6

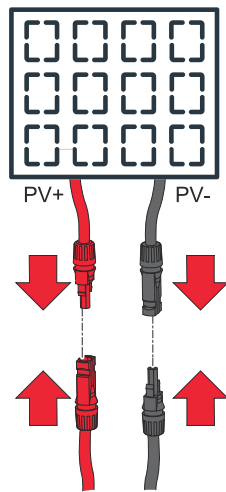

DC Voltage



+ / -

Connect the solar module strings (+/-).

max. 1000 V_{DC}

NOTE!

Danger due to polarity reversal at the terminals.

This may result in severe damage to the inverter.

- ▶ Use a suitable measuring instrument to check the polarity of the DC cabling.
- ▶ Use a suitable measuring instrument to check the voltage (**max. 1000 V_{DC}**)

7

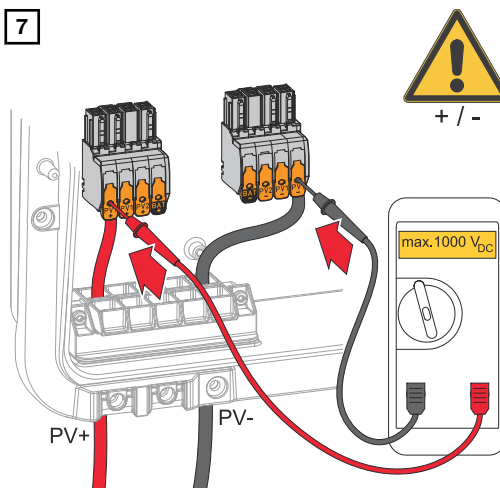

+ / -

Use a suitable measuring instrument to check the voltage and polarity of the DC cabling. Remove both DC terminals from the slots.

NOTE!

Risk due to overtorque at the strain-relief device.

Damage to the strain-relief device may result.

- ▶ Do not use a drill driver.

8

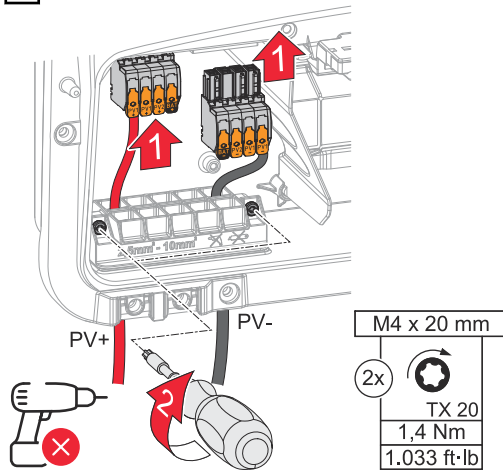

Insert the DC terminals into the respective slot until they engage. Fasten the screws of the strain-relief device to the housing using a screwdriver (TX20) and a torque of 1.3 - 1.5 Nm.

Connecting the battery to the inverter

Safety



WARNING!

Danger due to incorrect operation and incorrectly performed work.

This can result in serious injury and damage to property.

- ▶ Only a technical specialist is permitted to perform commissioning, maintenance, and service activities for inverters and batteries, and only within the scope of the technical regulations.
- ▶ Read the installation instructions and operating instructions from the respective manufacturer before installing and commissioning the equipment.



WARNING!

Danger from mains voltage and DC voltage from the PV module that are exposed to light, as well as batteries.

This can result in serious injury and damage to property.

- ▶ All connection, maintenance, and service work should only be carried out when the AC and DC sides have been disconnected from the inverter and battery, and are de-energized.
- ▶ Only a technical specialist is permitted to connect this equipment to the public grid.



WARNING!

Danger from damaged and/or contaminated terminals.

This can result in serious injury and damage to property.

- ▶ Prior to connection work, check the terminals for damage and contamination.
- ▶ Remove any contamination while the equipment is de-energized.
- ▶ Have defective terminals repaired by a technical specialist.

Connecting the battery on the DC side

NOTE!

Danger due to operation of the battery above the permissible altitude specified by the manufacturer.

Operating the battery above the permissible altitude can result in restricted operation, loss of operation, and unsafe states of the battery.

- ▶ Adhere to the manufacturer's instructions regarding the permissible altitude.
- ▶ Operate the battery only at the altitude specified by the manufacturer.

IMPORTANT!

Prior to installing a battery, ensure that the battery is switched off. Observe the max. DC cable length for the installation of third-party batteries according to the specifications of the manufacturer, see chapter [Suitable batteries](#) on page 31.

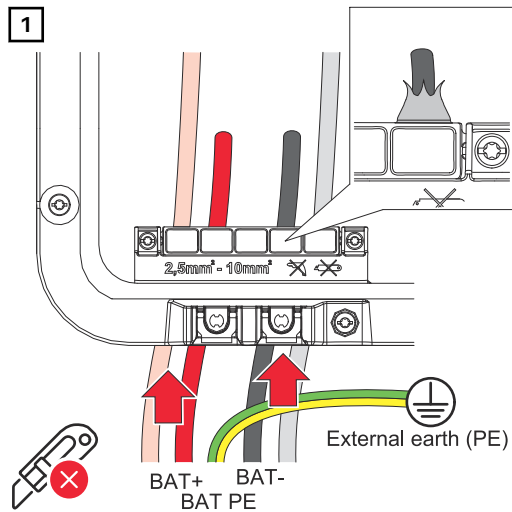

IMPORTANT!

Push the cables through the DC bushings by hand before stripping the insulation. This avoids twisting/bending single wires.

* The battery ground conductor must be connected externally (e.g., switch cabinet). When connecting an LG FLEX battery, the battery ground conductor can be connected in the inverter see chapter [Connecting the LG FLEX ground conductor](#) on page 74. Observe the minimum cross-section of the battery ground conductor.

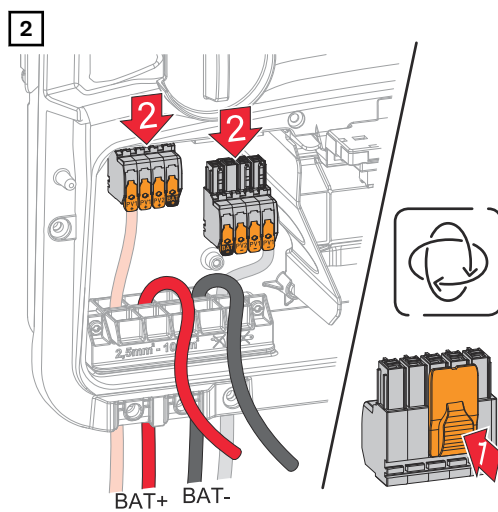

Remove the DC push-in terminals from the slots.

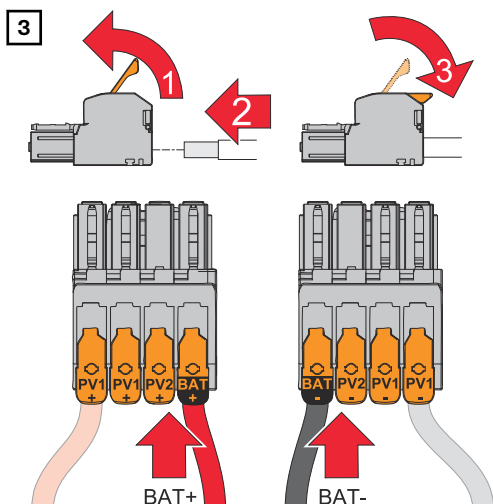

WARNING!

Danger from loose and/or incorrectly clamped single conductors in the terminal.

This can result in serious injury and damage to property.

- ▶ Only connect one single conductor in the slot provided for each terminal.
- ▶ Check that the single conductors are secure in the terminal.
- ▶ Make sure that the single conductor has been fully inserted into the terminal and that no single strands are protruding out of the terminal.

NOTE!

Danger due to overvoltage when using other slots on the terminal.

This may result in damage to the battery and/or the PV modules due to discharge.

- ▶ Only use the slots labeled "BAT" for connecting the battery.

Select the cable cross-section in accordance with the instructions in [Permissible cables for the electrical connection](#) from page 57.

Strip the insulation of the single conductors by 12 mm. Lift the operating lever of the terminal to open. Insert the stripped single conductor into the slot provided in the terminal as far as it will go. Then close the operating lever until it engages.

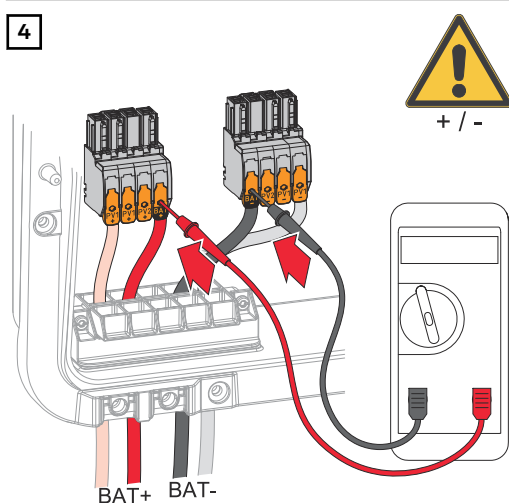

NOTE!

Danger due to polarity reversal at the terminals.

Serious damage to the PV system may result.

- ▶ Use a suitable measuring instrument to check the polarity of the DC cabling when the battery is switched on.
- ▶ The maximum voltage for the battery input must not be exceeded (see [Technical data](#) on page 172).

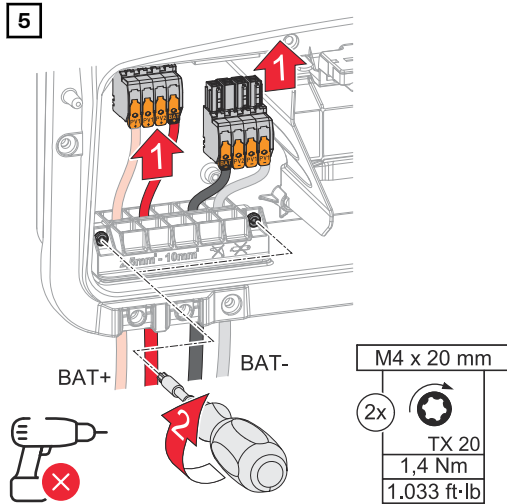

Insert the DC terminals into the respective slot until they engage. Fasten the screws of the cable guide to the housing using a screwdriver (TX20) and a torque of 1.3-1.5 Nm.

NOTE!

Risk due to overtorque at the strain-relief device.

Damage to the strain-relief device may result.

▶ Do not use a drill driver.

IMPORTANT!

Information for connection to the battery's DC connections can be found in the installation instructions from the relevant manufacturer.

Connecting the LG FLEX ground conductor

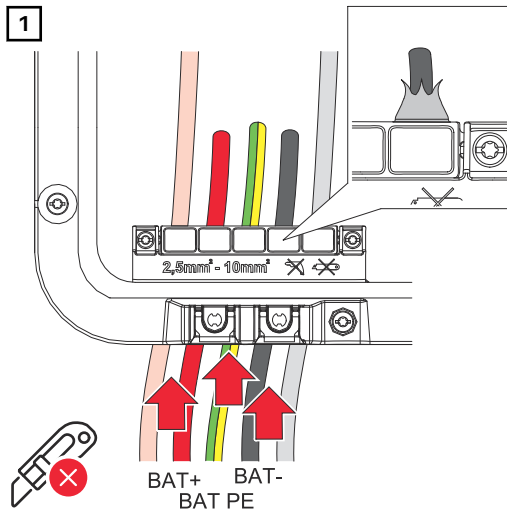

Push the ground conductor through the DC bushing by hand before stripping the insulation.

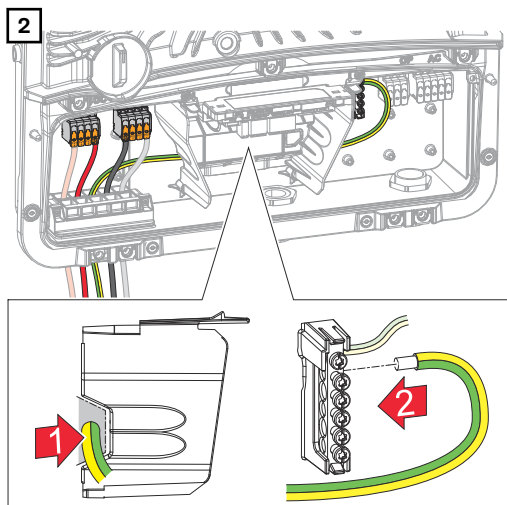

Place the battery ground conductor in the integrated cable duct of the connection area divider in the AC connection area. Fasten the battery ground conductor to the ground electrode terminal at the second input from above using a screwdriver (TX20) and a torque of 1.8-2 Nm.

IMPORTANT!

Information for connection to the battery's DC connections can be found in the installation instructions from the relevant manufacturer.

Connecting backup power - PV Point (OP)

Safety

WARNING!

Danger due to work that has been carried out incorrectly.

This can result in serious injury and damage to property.

- ▶ Installing and connecting an option must only be carried out by service personnel trained by Fronius and only within the scope of the respective technical regulations.
- ▶ Follow the safety rules.

WARNING!

Danger due to damaged and/or contaminated terminals.

This can result in serious injury and damage to property.

- ▶ Before making any connections, check the terminals for damage and contamination.
- ▶ Remove contamination in the de-energized state.
- ▶ Have defective terminals repaired by an authorized specialist.

NOTE!

During the switch from grid-connected operation to backup power mode, momentary interruptions will occur. The PV Point output requires PV power from the solar modules or a battery to power the connected loads.

Connected loads will not be supplied with power during the switchover.

- ▶ Do not connect any loads that require an uninterruptible supply (e.g., IT networks, life-sustaining medical devices).

IMPORTANT!

The valid national laws, standards, and provisions, as well as the specifications of the relevant grid operator are to be taken into account and applied.

It is highly recommended that the specific installation be agreed with the grid operator and explicitly approved by this operator. This obligation applies to system constructors in particular (e.g., installers).

Installation

NOTE!

All loads that have to be supplied via the OP terminal must be protected by means of a residual current circuit breaker.

In order to ensure the residual current circuit breaker operates properly, a connection must be established between the neutral conductor N' (OP) and ground.

For the circuit diagram recommended by Fronius, see [Circuit diagrams—PV Point](#) on page 197.

1

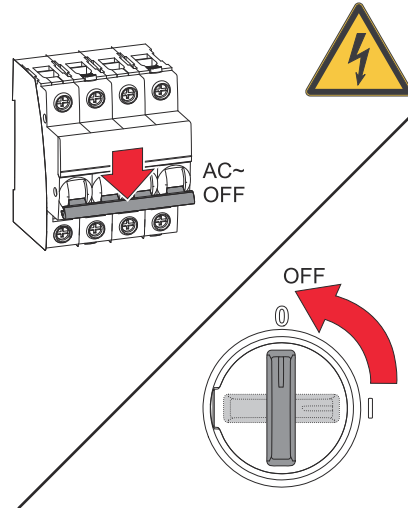

Switch off the automatic circuit breaker and DC disconnect. Turn the DC disconnect to the "off" switch setting.

2

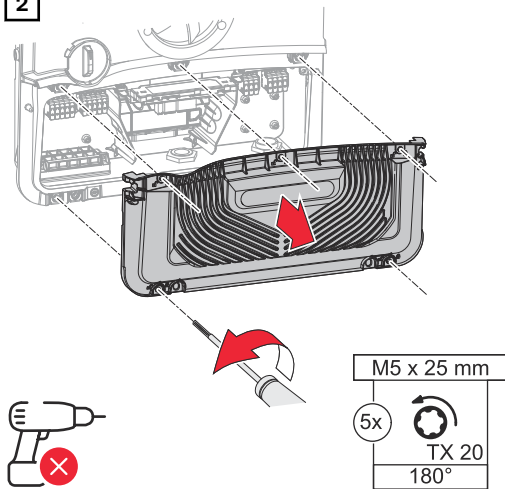

Loosen the 5 screws on the connection area cover by rotating them 180° to the left using a screwdriver (TX20). Remove the connection area cover from the device.

⚠ CAUTION!

Danger from faulty or incorrect bores.

This may lead to injuries to the eyes and hands as a result of flying debris and sharp edges, as well as damage to the inverter.

- ▶ When drilling, wear suitable protective goggles.
- ▶ Only use a step drill when drilling.
- ▶ Ensure that nothing on the inside of the device is damaged (e.g., the connection block).
- ▶ Adapt the diameter of the bore to match the corresponding connection.
- ▶ Deburr the bores using a suitable tool.
- ▶ Remove the drilling residues from the inverter.

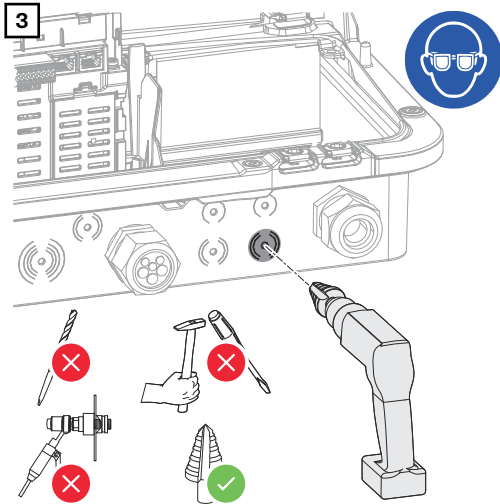

Drill out the optional cable guide with a step drill.

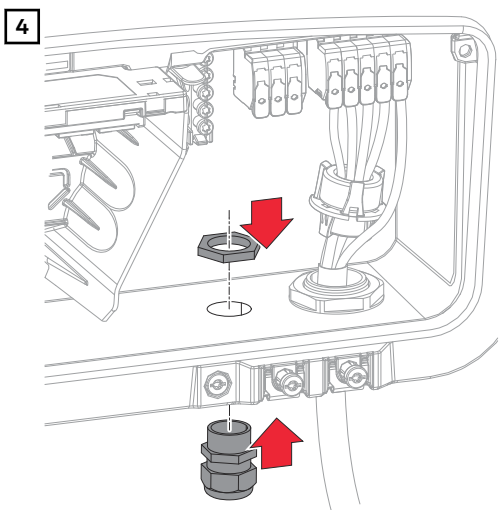

Insert the cable gland into the bore and fasten it using the torque specified by the manufacturer.

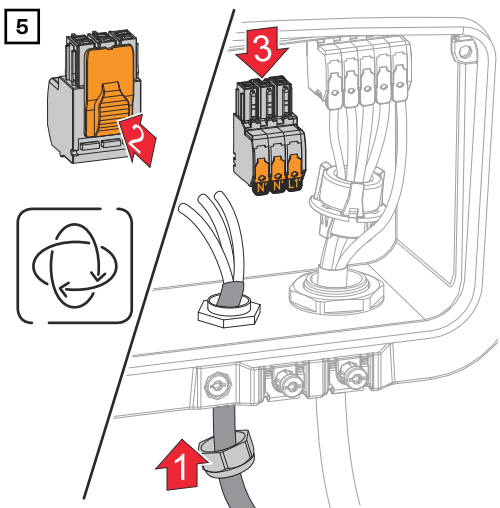

Guide the mains cable through the cable gland from below. Remove the OP terminal.

6

Strip 12 mm of insulation from the single conductors. The cable cross-section must be between 1.5 mm² and 10 mm².

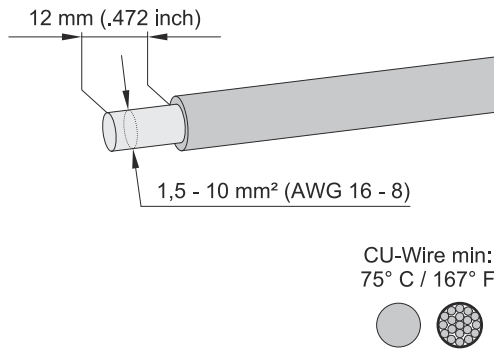

⚠ WARNING!

Danger from loose and/or incorrectly clamped single conductors in the terminal.

This can result in serious injury and damage to property.

- ▶ Only connect one single conductor in the slot provided for each terminal.
- ▶ Check that the single conductors are secure in the terminal.
- ▶ Make sure that the single conductor has been fully inserted into the terminal and that no single wires are protruding out of the terminal.

7

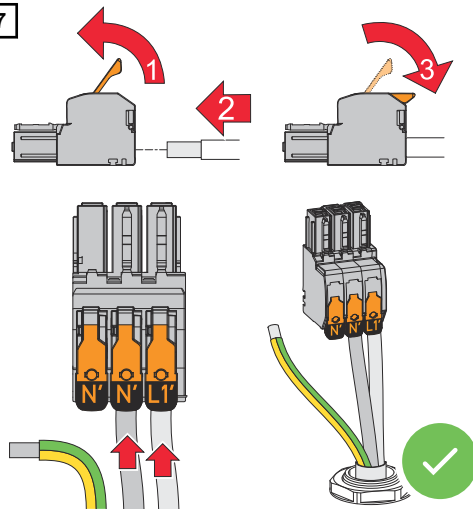

Lift to open the terminal's operating lever and insert the stripped single conductor into the slot provided, all the way up to the stop. Then close the operating lever until it engages.

- L1' Phase conductor
- N' Neutral conductor
- N' PEN conductor

8

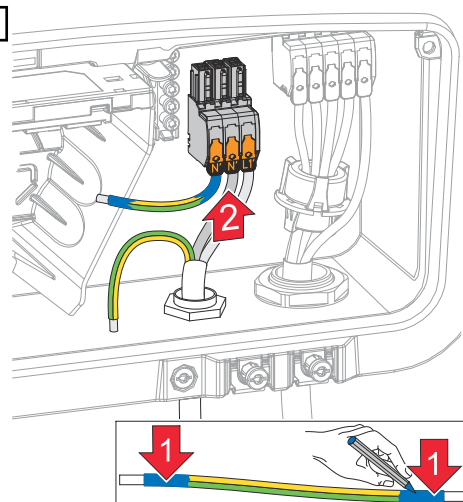

IMPORTANT!

The PEN conductor must be produced with ends that are permanently marked blue, according to the national provisions, and have a cross-section of 10 mm².

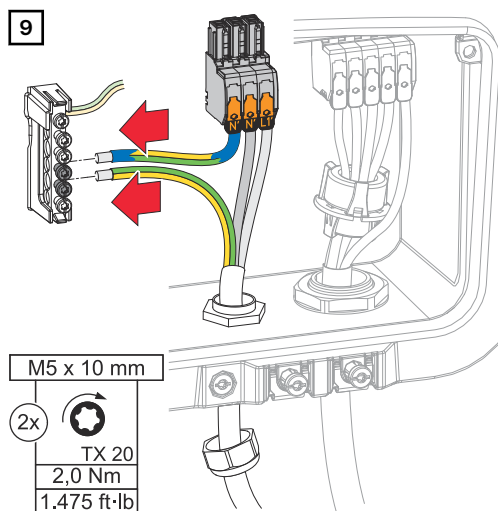

Fasten the ground conductor and PEN conductor to the ground electrode terminal using a screwdriver (TX20) and a torque of 2 Nm.

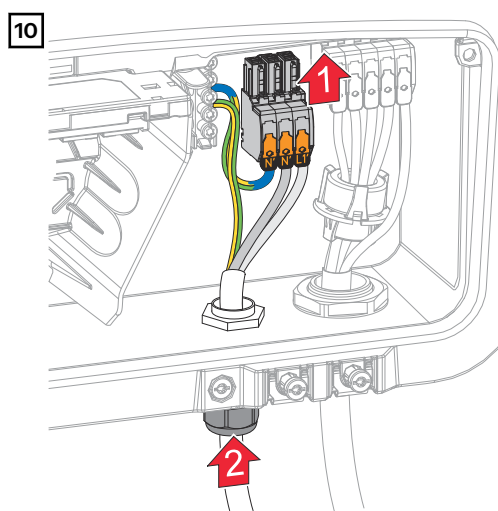

Insert the OP terminal into the OP slot until it engages. Tighten the union nut of the cable gland.

Testing backup power mode

Testing backup power mode:

- during first-time installation and configuration
- after working on the switch cabinet
- during ongoing operation (recommendation: at least every 6 months)

A battery charge of min. 30% is recommended for test mode.

A description of how to run the test mode can be found in the [checklist - Backup power](https://www.fronius.com/de/download-center?search-word=42,0426,0365) (https://www.fronius.com/de/download-center?search-word=42,0426,0365).

Connecting the data communication cables

Modbus participants

The inputs M0 and M1 can be freely selected. A maximum of four Modbus participants can be connected to the Modbus terminal at inputs M0 and M1.

IMPORTANT!

Only one primary meter, one battery, and one Ohmpilot can be connected per inverter. Due to the high data transfer of the battery, the battery occupies two subscribers. If the **Inverter Control via Modbus** function is activated in the **Communication > Modbus** menu area, no Modbus participants are possible. It is not possible to send and receive data at the same time.

Example 1:

Input	Battery	Fronius Ohmpilot	Number of primary meters	Number of secondary meters
Modbus 0 (M0)	✗	✗	0	4
	✓	✗	0	2
	✓	✓	0	1
Modbus 1 (M1)	✗	✗	1	3

Example 2:

Input	Battery	Fronius Ohmpilot	Number of primary meters	Number of secondary meters
Modbus 0 (M0)	✗	✗	1	3
Modbus 1 (M1)	✗	✗	0	4
	✓	✗	0	2
	✓	✓	0	1

Routing data communication cables

IMPORTANT!

If data communication cables are wired into the inverter, observe the following points:

- Depending on the number and cross-section of the wired data communication cables, remove the corresponding blanking plugs from the sealing insert and insert the data communication cables.
- Make sure that you insert the corresponding blanking plugs into any free openings on the sealing insert.

IMPORTANT!

Ingress protection rating IP 66 cannot be ensured if blanking plugs are missing or incorrectly inserted.

1

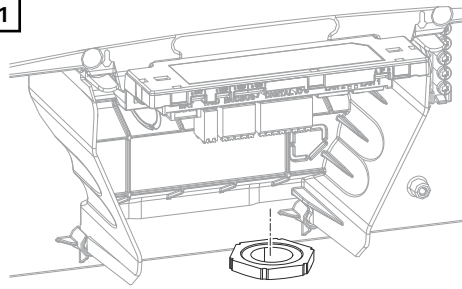

Remove the union nut on the cable gland and press the sealing ring with the blanking plugs out from the inside of the device.

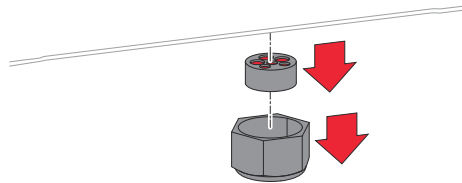

2

3x Ø 4,9 - 5,5 mm (.193 - .217 inch)
3x Ø 6,7 - 8,5 mm (.264 - .335 inch)

Open up the sealing ring at the location where the blanking plugs are to be removed.

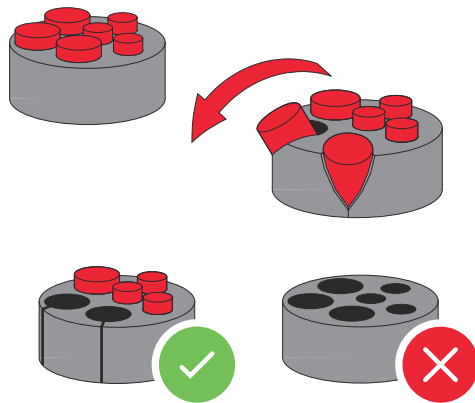

* Remove the blanking plugs with a sideways motion.

3

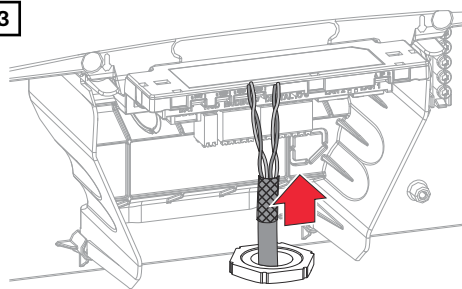

First, guide the data cables through the union nut of the cable gland and then through the housing opening.

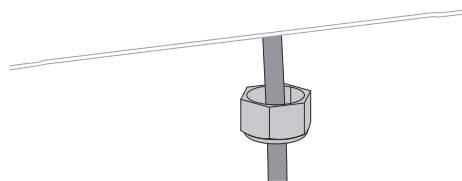

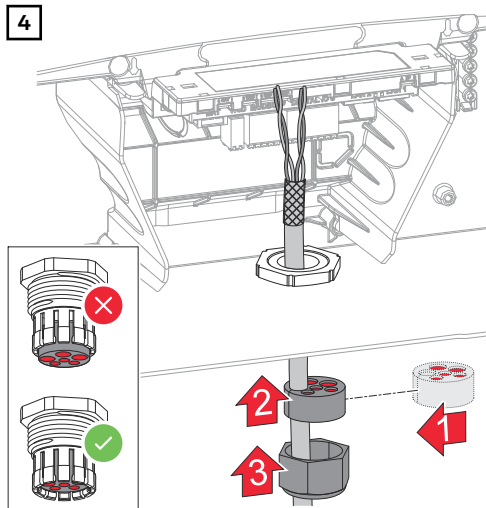

Insert the sealing ring between the union nut and the housing opening. Press the data cables into the seal's cable guide. Then press in the seal until it reaches the underside of the cable gland.

Connecting the battery communication cable

Modbus RJ45

IMPORTANT!

For this connection version, the BAT switch on the data communication area must be in position 1.

NOTE!

Power supply

Voltage is present at the connection. If network devices (e.g., WiFi routers) are connected, the device may be damaged.

► Only connect batteries to the battery connection

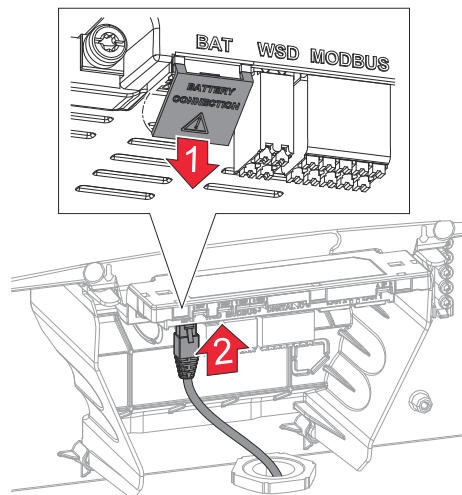

- 1 Knock out the protective cover
- 2 Connect the cable to the RJ45 socket

✓ The LEDs on the RJ45 socket light up red when the battery connection is active.

Modbus terminal

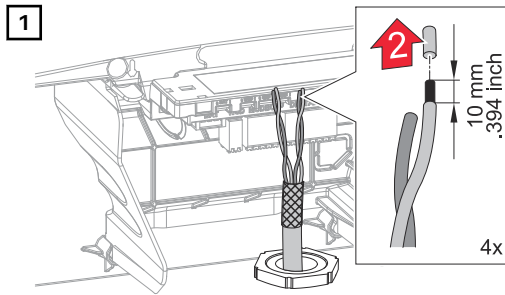

Strip 10 mm of insulation from the single conductors and fit the ferrules if necessary.

IMPORTANT!

If several single conductors are connected to an input of the push-in terminals, connect the single conductors with a corresponding ferrule.

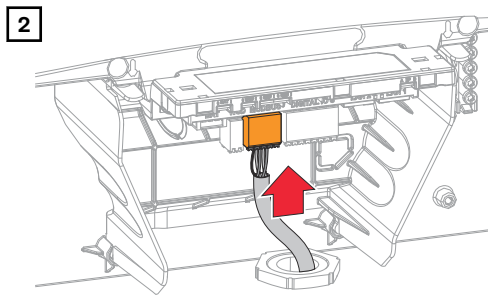
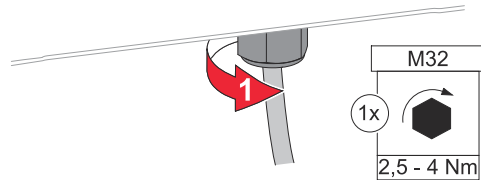

Insert the cables into the respective slot and check the cables are securely retained.

IMPORTANT!

Use a twisted cable pair for data cables that belong together.

Twist the cable shield and insert into the "SHIELD" slot.

Modbus		Battery	Modbus
GND	V+		M0+
M0-	M0+		M0-
SHIELD	SHIELD		GND
M1-	M1+		V+
GND	V+		Shield

IMPORTANT!

Improperly fitted shielding can cause data communication problems.

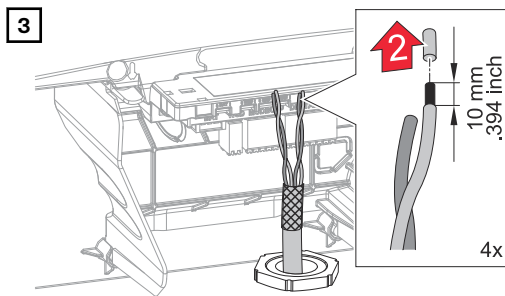

Fasten the union nut of the cable gland with a torque of min. 2.5 - max. 4 Nm.

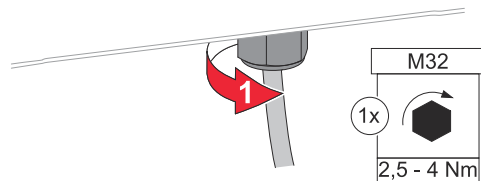

For the circuit diagram recommended by Fronius, see [System circuit diagrams](#) on page 185.

Terminating resistors

It may be possible for the system to function without terminating resistors. However, owing to interference, the use of terminating resistors according to the following overview is recommended for trouble-free operation.

For permissible cables and max. distances for the data communication area, refer to the chapter headed [Permitted cables for the data communication connection](#) on page 58.

IMPORTANT!

Terminating resistors that are not positioned as illustrated can result in interference in the data communication.

OPTION 1

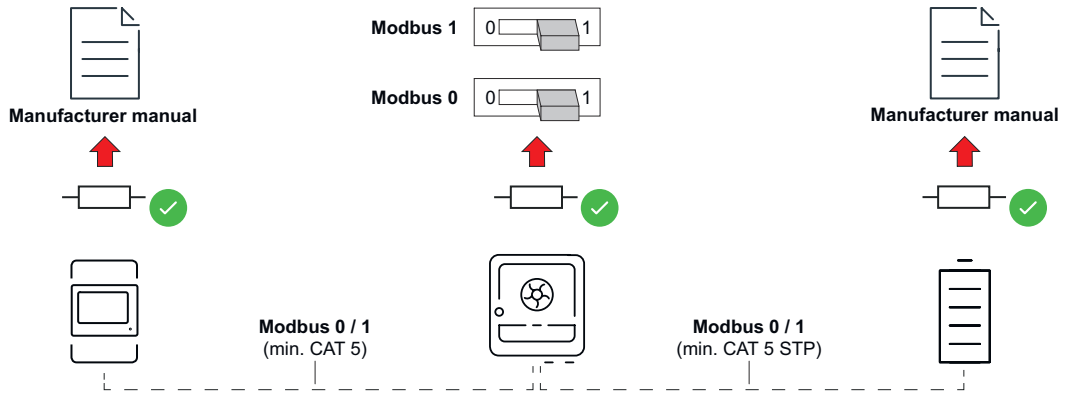

OPTION 2

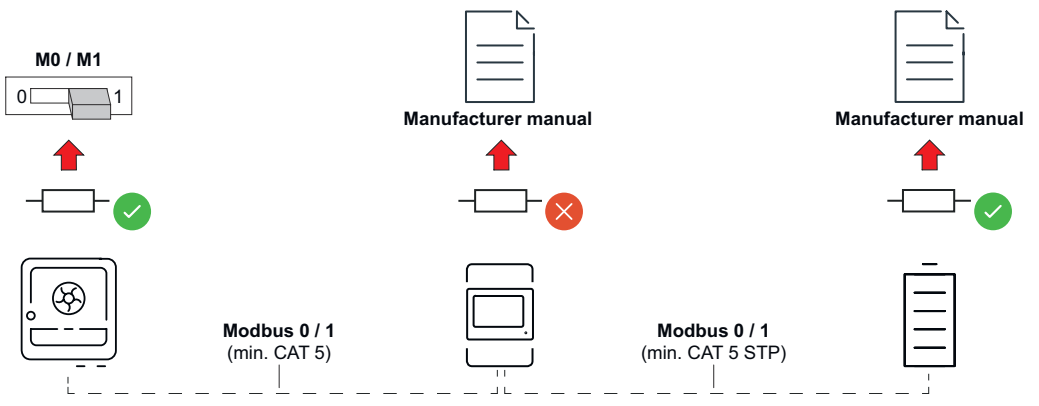

OPTION 3

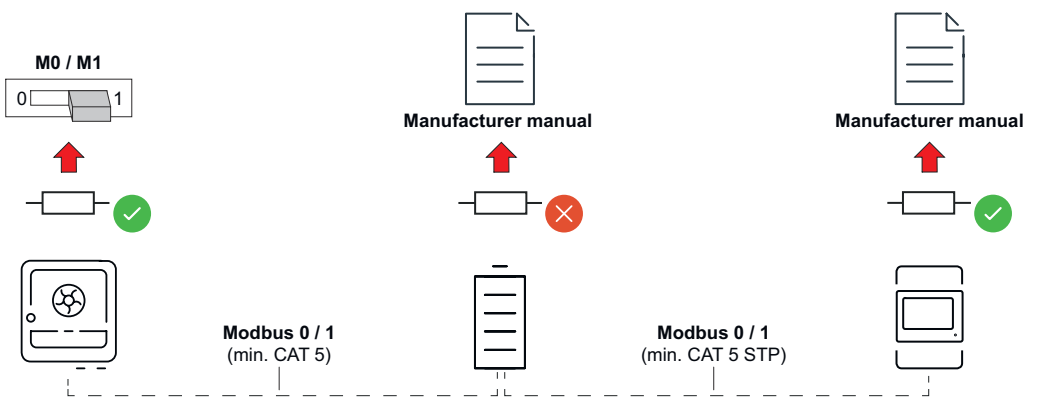

Installing the WSD (wired shutdown)

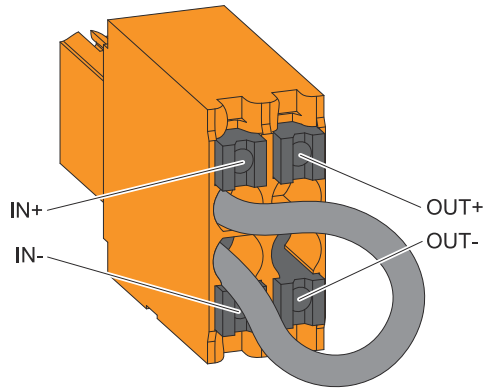

IMPORTANT!

The push-in WSD terminal in the inverter's connection area is delivered with a bypass ex works as standard. The bypass must be removed when installing a trigger device or a WSD chain.

The WSD switch of the first inverter with connected trigger device in the WSD chain must be in position 1 (master). The WSD switch of all other inverters should be in position 0 (secondary device).

Max. distance between 2 devices: 100 m
Max. Number of devices: 28

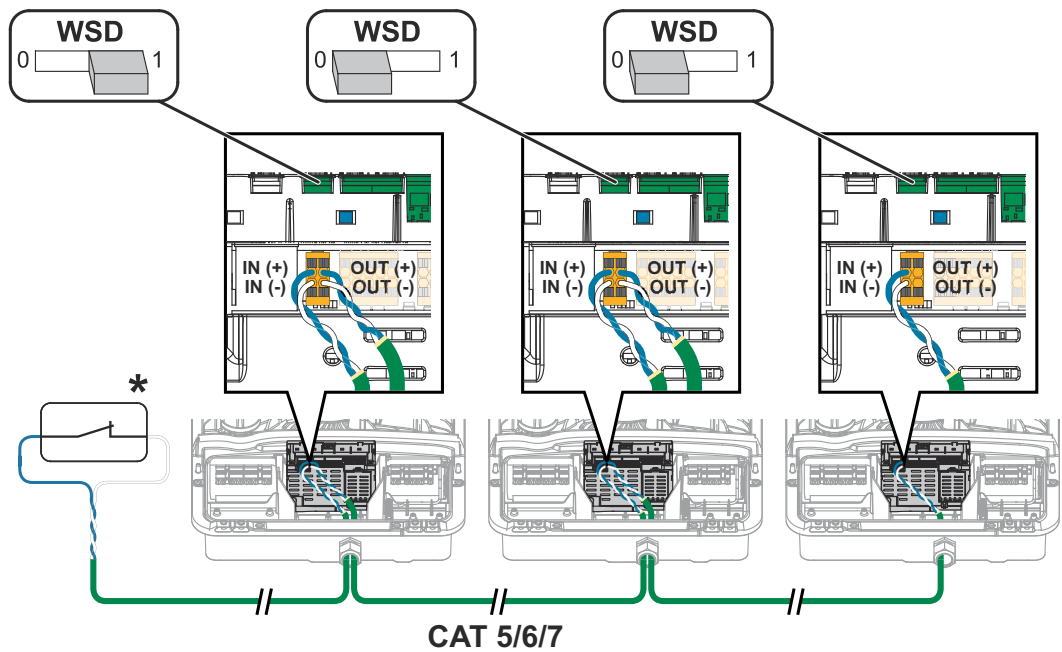

* Floating contact of the trigger device (e.g., central grid and system protection). If several floating contacts are used in a WSD chain, these must be connected in series.

Closing and commissioning the inverter

Closing the inverter's connection area/housing cover, and commissioning

NOTE!

The housing cover is fitted with a lock for safety reasons, which allows the housing cover on the inverter to be pivoted only when the DC disconnecter is off.

- ▶ Only clip and pivot the housing cover into the inverter when the **DC disconnecter is switched off**.
- ▶ Do not use excessive force to clip in and pivot the housing cover.

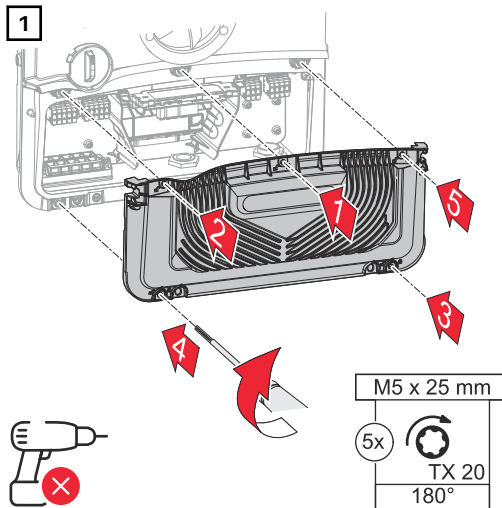

Place the cover on the connection area. Tighten the 5 screws by rotating them 180° to the right in the indicated order using a screwdriver (TX20).

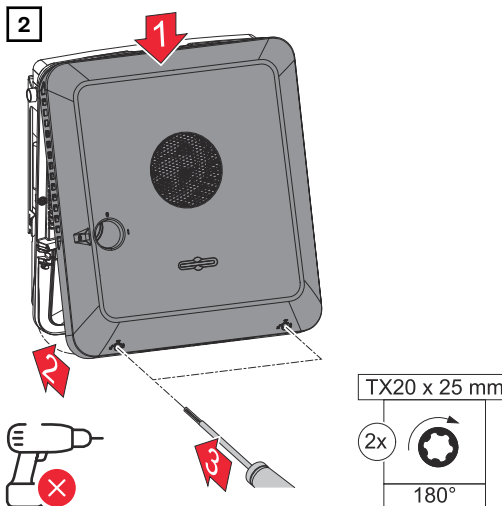

Clip the housing cover into the inverter from above. Press on the lower part of the housing cover and tighten the 2 screws by rotating them 180° to the right using a screwdriver (TX20).

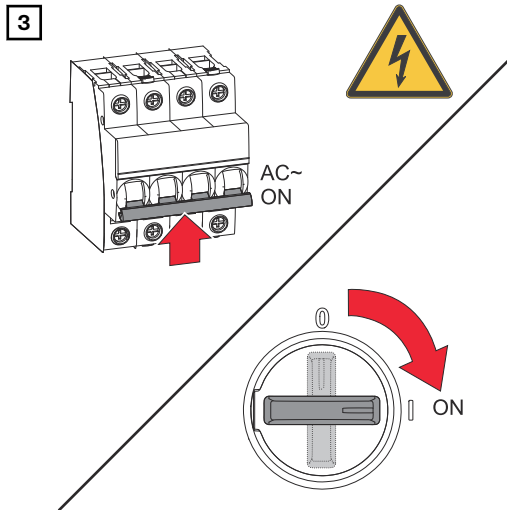

Turn the DC disconnecter to the "on" switch setting. Turn on the automatic circuit breaker. For systems with a battery, observe the switch-on sequence according to the chapter [Button functions and LED status indicator](#) on page 31.

IMPORTANT! Open the WiFi access point with the optical sensor, see chapter [Suitable batteries](#) on page 39

Starting the inverter for the first time

When starting the inverter for the first time, various setup settings must be configured.

If the setup is canceled before completion, the input data is not saved and the start screen with the installation wizard is shown once again. The data is saved in the event of an interruption, e.g., a power failure. Commissioning is continued at the point at which the interruption occurred after the power supply is restored. If the setup was interrupted, the inverter feeds energy into the grid at maximum 500 W and the operating status LED flashes yellow.

The country setup can only be set when starting the inverter for the first time. If the country setup needs to be changed at a later date, contact your installer/technical support.

Installation with the app

The Fronius Solar.start app is required for installation. Depending on the mobile device used to perform the installation, the app is available on the relevant platform.

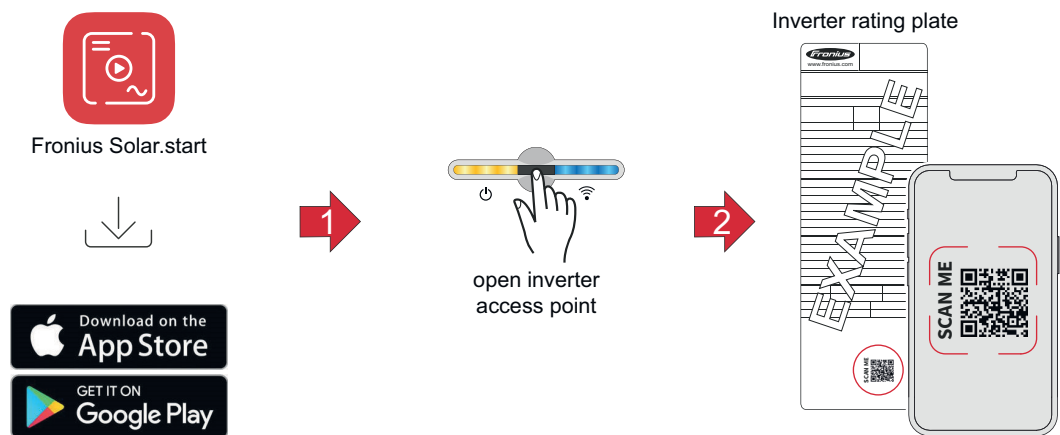

- 1 Download and install the Fronius Solar.start app.
- 2 Open the access point by touching the sensor .
 - ✓ *Communication LED flashes blue.*
- 3 Open the Fronius Solar.start app and follow the installation wizard. Scan the QR code on the rating plate with a smartphone or tablet to connect to the inverter.

- 4 Add system components in Fronius Solar.web and commission the PV system.

The network wizard and product setup can be performed independently. A network connection is required for the Fronius Solar.web installation wizard.

Installation with the browser

The network wizard and product setup can be performed independently. A network connection is required for the Fronius Solar.web installation wizard.

WiFi:

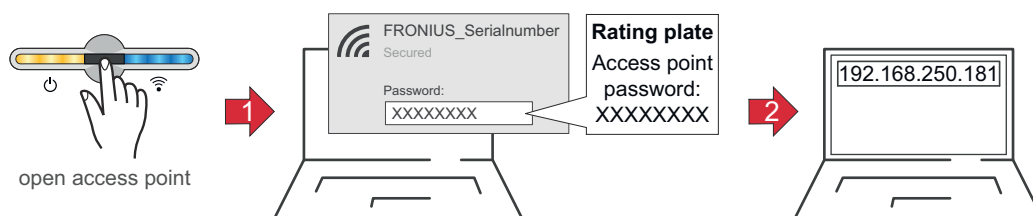

- 1 Open the access point by touching the sensor .
 - ✓ *Communication LED flashes blue.*
- 2 Establish the connection to the inverter in the network settings (the inverter is displayed with the name "FRONIUS_" and the serial number of the device).
- 3 Enter the password from the rating plate and confirm.

IMPORTANT!
To enter the password, first select the **Connect using a security key instead** link in order to establish the connection with the password.
- 4 Enter the IP address 192.168.250.181 in the address bar of the browser and confirm. The installation wizard opens.
- 5 Follow the installation wizard and complete the installation in the individual areas.
- 6 Add the system components in Fronius Solar.web and commission the PV system.

Ethernet:

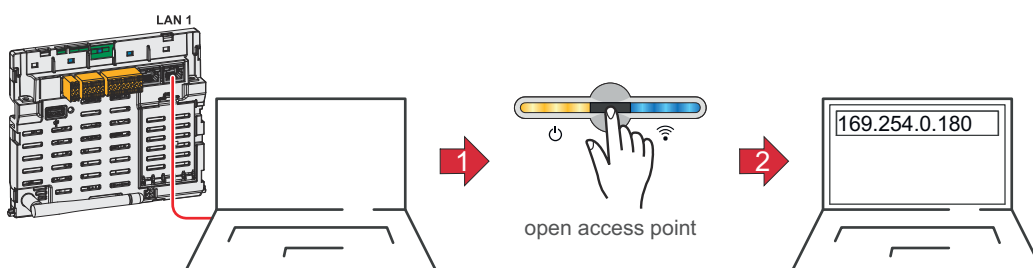

- 1 Establish a connection to the inverter (LAN1) using a network cable (min. CAT5 STP).
- 2 Open the access point by touching the sensor once .
 - ✓ *Communication LED flashes blue.*
- 3 Enter the IP address 169.254.0.180 in the address bar of the browser and confirm. The installation wizard opens.
- 4 Follow the installation wizard and complete the installation in the individual areas.
- 5 Add the system components in Fronius Solar.web and commission the PV system.

De-energizing the inverter and switching it back on

De-energizing the inverter and switching it back on

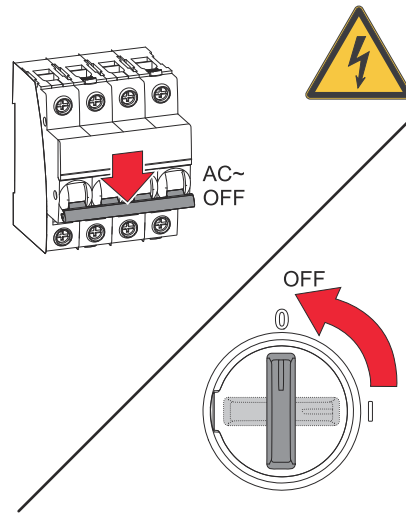

Disconnecting the inverter from the power supply:

- 1 Turn off the automatic circuit breaker.
- 2 Turn the DC disconnect to the "off" switch setting.

IMPORTANT!

Wait for the capacitors of the inverter to discharge!

Switching on the inverter:

If the inverter has not been in operation for six months or more after installation, it must be tested before commissioning.

- 1 Turn the DC disconnect to the "on" switch setting.
- 2 Turn on the automatic circuit breaker.

Settings - User interface of the in- verter

User settings

User login

- 1 Open the user interface of the inverter in the browser.
- 2 In the **Login** menu area, log in with username and password, or, in the **User > User Login** menu area, log in with username and password.

IMPORTANT!

Depending on the authorization of the user, settings can be made in the individual menu areas.

Selecting languages

- 1 In the **User > Language** menu area, select the desired language.

Device configuration

Components All available components of the system can be added via **Add component+**.

PV Generator

Activate the MPP tracker and enter the connected PV output in the relevant field. In the case of combined solar module strings, **PV 1 + PV 2 connected in parallel** must be activated.

Meter

Primary meter

IMPORTANT!

For problem-free operation with further energy generators, it is important to install and configure a Fronius Smart Meter as the **primary meter** at the feed-in point. The inverter and further generators must be connected to the public grid via the Fronius Smart Meter. Only one **primary meter** can be configured in the system.

This setting has an effect on the behavior of the inverter during the night. If the **primary meter** has been configured, the inverter remains permanently connected to the grid in order to enable it to draw energy from other generators at any time.

If the **primary meter** has not been configured, the inverter switches to standby mode as soon as there is no more PV power available. No energy management specification is sent to the battery (e.g., minimum state of charge reached). The message "Power low" is displayed. The inverter starts again as soon as an energy management specification is sent or sufficient PV power is available.

Secondary meter

In addition to the **primary meter**, further **secondary meters** can be added to the system to record the load curves of individual loads and generators (e.g., heat pump, wind power plant, etc.) and provide the measured data for energy profiling in Fronius Solar.web.

1. After connecting the meter, select a category:
 - **Primary meter**
 - **Secondary meter**
2. Select one of the following device types:
 - **Modbus RTU**
 - **Modbus TCP**
 - **MQTT** (available **MQTT device** is displayed automatically)

NOTE!

For communication via MQTT and Modbus TCP, install the inverter and Smart Meter in the same sub-network.

3. Additionally define the following parameters for the Smart Meter:
 - **Application** of primary meter (**Feed-in point** or **Load branch**)
 - **Application** of secondary meter (**Production meter** or **Secondary meter**)
 - **Name**
 - **Category** (e.g., **inverter, heat pump**)
 - **IP Address** (for Modbus TCP)
 - **Port** (502 or 1502, for Modbus TCP only)
 - **Modbus Address** (for Modbus RTU and TCP)

The Watt value for the production meter is the sum of all production meters.
The Watt value for the secondary meter is the sum of all secondary meters.

Battery

If the **SoC Limit Mode** is set to **Auto**, the values **SoC Minimum** and **SoC Maximum** are preset according to the technical specifications of the battery manufacturer.

If the **SoC Limit Mode** is set to **Manual**, the values **SoC Minimum** and **SoC Maximum** can be changed after consultation with the battery manufacturer within the framework of their technical specifications. In a backup power situation, the set values are not taken into account.

The setting **Allow battery charging from other generators in the home network** activates/deactivates charging of the battery from other generators.
The power consumption of the Fronius inverter can be restricted by specifying a value in the **Max. Charging Power from AC** field. As a maximum, a power consumption equal to the AC rated power of the Fronius inverter is possible.

The setting **Allow battery charging from public grid + Allow battery charging from other generators in the home network** activates/deactivates the charging of the battery from the public grid and, if present, from other generators in the home network.

The normative or compensatory specifications must be taken into account for this setting. Irrespective of this setting, necessary service-related charging from the public grid is performed (e.g., forced re-charging to protect against deep discharge).

IMPORTANT!

Fronius accepts no liability for damage to third-party batteries.

Ohmpilot

All the Ohmpilots available in the system are displayed. Select the desired Ohmpilot and add to the system via **Add**.

Functions and I/Os

Backup power mode

In backup power mode, select between **Off** and **PV Point**.

IMPORTANT!

When configuring the **PV Point** backup power mode, observe the instructions in chapter [Safety](#).

Backup Nominal Voltage

When backup power mode is activated, select the nominal voltage of the public grid.

SoC warning level

In backup power mode, a warning is emitted when this residual battery capacity is reached.

Reserve Capacity

The set value results in a residual capacity (depending on the battery capacity) that is reserved for backup power situations. The battery is not discharged below the residual capacity in grid connected mode.

Load Management

Up to four pins for the load management can be selected here. Further settings for the load management are available in the **Load Management** menu item.
Default: Pin 1

Australia - Demand Response Modes (DRM)

The pins for control via DRM can be set here:

Mode	Description	Information	DRM Pin	I/O pin
DRM0	Inverter disconnects from the grid	DRM0 occurs in the event of an interruption or short circuit on the REF GEN or COM LOAD lines, or in the event of invalid combinations of DRM1 - DRM8. The grid relays open.	REF GEN COM LOAD	IO4 IO5
DRM1	Import $P_{nom} \leq 0\%$ without disconnection from grid	currently not supported	DRM 1/5	IN6
DRM2	Import $P_{nom} \leq 50\%$	currently not supported	DRM 2/6	IN7
DRM3	Import $P_{nom} \leq 75\%$ & $+Q_{rel}^* \geq 0\%$	currently not supported	DRM 3/7	IN8
DRM4	Import $P_{nom} \leq 100\%$	currently not supported	DRM 4/8	IN9
DRM5	Export $P_{nom} \leq 0\%$ without disconnection from grid	currently not supported	DRM 1/5	IN6
DRM6	Export $P_{nom} \leq 50\%$	currently not supported	DRM 2/6	IN7
DRM7	Export $P_{nom} \leq 75\%$ & $-Q_{rel}^* \geq 0\%$	currently not supported	DRM 3/7	IN8
DRM8	Export $P_{nom} \leq 100\%$	currently not supported	DRM 4/8	IN9

The percentage specifications always relate to the rated device power.

IMPORTANT!

If the **Australia - Demand Response Modes (DRM)** function is activated and no DRM control is connected, the inverter switches to standby mode.

Battery Grid Import Limit (§ 14a EnWG)

Define a pin for the implementation of the regulatory requirement per § 14a EnWG.

Demand Response Modes (DRM)

Here you can enter a value for the apparent power input and the apparent power output for the Australia country setup.

Inverter

Enforce Standby

When this function is activated, grid power feed operation of the inverter is interrupted. This makes it possible to shut down the inverter without power and protect its components. The standby function is automatically deactivated when the inverter is restarted.

Fan test

IMPORTANT!

For settings in this menu item, select the **Technician** user, enter the password for the **Technician** user, and confirm. Settings may only be made by trained and qualified personnel.

Use this function to check whether the fans of the inverter are working correctly based on acoustics, for example after replacing a fan.

1 Click **Start fan test**

- ✓ *The inverter successively activates all fans that are running at partial load during the test phase to avoid unnecessary noise. The inverter is in standby during this time.*

The test takes around 30 seconds per fan. The inverter then switches back to normal operation. Use the **Stop fan test** function to stop the test manually.

PV 1 and PV 2

Parameter	Value range	Description
Mode	Off	The MPP tracker is deactivated.
	Auto	The inverter uses the voltage at which the maximum possible output of the MPP tracker is possible.
	Fixed	The MPP tracker uses the voltage defined in UDC fixed .
UDC fixed	80 - 530 V	The inverter uses the fixed voltage that is used on the MPP tracker.
Dynamic Peak Manager	Off	Function is deactivated.
	On	The entire solar module string is checked for optimization potential and the best possible voltage for grid power feed operation is determined.
	On (MLSD)	The function is optimized for systems with Module Level Shutdown devices (MLSD) and is not suitable for PV optimizers.
Rated power	0-2,000,000	Rated output of PV input

Ripple Control

Ripple control signals are signals that are sent by an energy company in order to switch controllable loads on and off. The inverter damps or amplifies the ripple control signals, depending on the installation situation. This can be counteracted if necessary by applying the following settings.

Parameter	Value range	Description
Reduction of influence	Off	Function is deactivated.
	On	Function is activated.
Frequency of the ripple control signal	100 - 3000 Hz	The frequency specified by the energy company must be entered here.
Grid inductance	0.00001 - 0.005 H	The value measured at the feed-in point must be entered here.

Measures to prevent FI/RCMU false alarms
(when using a 30 mA residual current circuit breaker)

NOTE!

A residual current circuit breaker for the AC connecting cable may be required depending on national regulations, the grid operator, and other conditions.

A type A residual current circuit breaker is generally sufficient in this case. Nevertheless, false alarms can be triggered for the type A residual current circuit breaker in individual cases and depending on local conditions. For this reason, Fronius recommends using a residual current circuit breaker suitable for frequency inverters with a release current of least 100 mA, taking into account national provisions.

Parameter	Value range	Description
Leakage current factor to reduce RCMU/FI false tripping	0 - 0.25 (default: 0.16)	By reducing the setting value, the leakage current is reduced and the intermediate circuit voltage is increased, which slightly lowers the efficiency. <ul style="list-style-type: none"> - A set value of 0.16 ensures optimum efficiency. - A setting value of 0 enables minimum leakage currents.
Shutdown before 30 mA RCD triggers	Off	The function for reducing false tripping of the residual current circuit breaker is deactivated.
	On	The function for reducing false tripping of the residual current circuit breaker is activated.
Rated non-tripping fault current limit value	0.015 - 0.3	Value of the non-tripping residual current specified by the manufacturer for the residual current circuit breaker at which the residual current circuit breaker does not switch off under specified conditions.

Insulation warning

Parameter	Value range	Description
Insulation warning	Off	The insulation warning is deactivated.
	On	The insulation warning is activated. A warning is output in the event of an insulation fault.
Insulation measurement mode	Exact	Insulation monitoring takes place with the highest degree of accuracy. The measured insulation resistance is displayed on the user interface of the inverter.
	Fast	Insulation monitoring takes place with a lesser degree of accuracy. The duration of the insulation measurement is shortened. The insulation resistance value is not displayed on the user interface of the inverter.

Parameter	Value range	Description
Threshold for the insulation warning	100,000 - 10,000,000	If the value drops below the threshold, status code 1083 is displayed on the user interface of the inverter.

Continuous residual current monitoring

Parameter	Value range	Description
Limit value	0.03-0.3A	Defines the limit value for shutdown in the event of residual current.

Backup power

Parameter	Value range	Description
Backup power nominal voltage	220 - 240 V	The nominal phase voltage that the inverter outputs in backup power mode.
Backup power frequency offset	-5 to +5 Hz	The setting value can be used to reduce or increase the backup power frequency (see Technical data) by the offset value. The default value is +3 Hz. Connected loads (e.g., Fronius Ohmpilot) detect active backup power mode based on the change in frequency and react accordingly (e.g., activation of energy-saving mode). IMPORTANT! If another AC source is available in the system, the backup power frequency must not be changed. The default value (+3 Hz) prevents the following events: <ul style="list-style-type: none"> - Feeding in further AC sources in backup power mode in parallel to the inverter. - Overvoltages - Shutting down the respective backup power circuit
Backup power undervoltage protection limit value $U_{<}$ [pu]	0 - 2 %V	This setting value represents the limit value for shutting down backup power mode e.g., setting value 0.9 = 90% of the nominal voltage.
Backup power undervoltage protection time $U_{<}$	0.04 - 20 s	Trip time for falling below the backup power undervoltage protection limit value.
Backup power surge protection limit value $U_{>}$ [pu]	0 - 2 %V	This setting value represents the limit value for shutting down backup power mode e.g., setting value 1.1 = 110% of the nominal voltage.
Backup power surge protection time $U_{>}$	0.04 - 20 s	Trip time for exceeding the backup power surge protection limit value.

Parameter	Value range	Description
Fast under-voltage protection / ground fault protection limit value U<< [pu]	0-100%V	Defines the voltage limit value below which rapid undervoltage protection or protection against ground faults is triggered. Typically, a value such as 0.3 pu (30% of the nominal voltage) is set here.
Fast under-voltage protection / ground fault protection time U<<	0 - 10 s	Defines the maximum time (in seconds) for which the voltage may be below the set limit value, after which the inverter switches off. This value must be ≤ 0.4 s in accordance with ÖVE E 8101.
Backup power restart delay	0 - 600 s	Waiting time for restarting backup power mode following a shutdown.
Backup power restart attempts	1 - 10	The maximum number of automated restart attempts. Once the maximum number of automated restart attempts has been reached, service message 1177 must be manually acknowledged.
External frequency monitoring in backup power mode (only for Italy)	Off	Function is deactivated
	On	For Full Backup power mode in Italy, activate external frequency monitoring. The inverter checks the mains frequency before ending backup power mode. If the mains frequency is within the permitted limits, the loads are connected to the public grid.
Backup power short circuit switch-off time	0.001 - 60 s	If a short circuit occurs during backup power mode, backup power mode is interrupted within the set time.

Energy management

Permitted maximum battery charge from the public grid

In Germany, new rules for charging batteries came into force on January 1, 2024. When applying §14a EnWG, the charging current must be reduced to a maximum of 4.2 kW by the grid operator for dimming controllable load equipment in accordance with §14a EnWG.

In order to document implementation of the control command, the inverter can be connected to Fronius Solar.web and ensure a permanent Internet connection. In addition, in the menu item **Device configuration > Functions & I/Os**, activate the **Battery Grid Import Limit (§ 14a EnWG)**.

Battery management

State of charge settings

If the **SoC Limit Mode** is set to **Auto**, the values **SoC Minimum** and **SoC Maximum** are preset according to the technical specifications of the battery manufacturer.

If the **SoC Limit Mode** is set to **Manual**, the values **SoC Minimum** and **SoC Maximum** can be changed after consultation with the battery manufacturer within the framework of their technical specifications. In a backup power situation, the set values are not taken into account.

If **Battery charging from other sources** is activated, the following options are available:

- The setting **From other generators in the home network and from public grid** activates/deactivates the charging of the battery from the public grid and, if present, from other generators in the home network. The normative or compensatory specifications must be taken into account for this setting. Irrespective of this setting, necessary service-related charging from the public grid is performed (e.g., forced re-charging to protect against deep discharge).
- The setting **From other generators in the home network** activates/deactivates charging of the battery from other generators. The power consumption of the Fronius inverter can be restricted by specifying a value in the **Max. Charging Power from AC** field. As a maximum, a power consumption equal to the AC rated power of the Fronius inverter is possible.

SoC warning level

In backup power mode, a warning is emitted when this residual battery capacity is reached.

Reserve Capacity

The set value results in a residual capacity (depending on the capacity of the battery) that is reserved for backup power situations. The battery is not discharged below the residual capacity in grid connected mode.

IMPORTANT!

Fronius accepts no liability for damage to third-party batteries.

Time-dependent battery control

Using the Time-dependent battery control, it is possible to specify, restrict, or prevent the charging/discharging of the battery at/to a defined power.

Battery Management is influenced, for example, by the following settings:

- Permitted battery charging from the public grid
- Power limit of the inverter, energy storage device, or overall system
- Control specifications via Modbus
- Self-consumption optimization

IMPORTANT!

The defined regulations for battery control have the second lowest priority after Self-Consumption Optimization. Depending on the configuration, the regulations may not be fulfilled due to other settings.

The following values can be selected for the Time-dependent battery control regulations:

- **Max. charging power**
The max. charging power of the battery is the value set in the **Power** input field.
If no feed into the public grid and/or direct consumption in the home is possible, the set value **Max. charging power** is ignored and the battery is charged with the generated energy.
- **Min. charging power**
The min. charging power of the battery is the value set in the **Power** input field.
- **Max. discharge power**
The max. discharge power of the battery is the value set in the **Power** input field.
- **Min. discharge power**
The min. discharge power of the battery is the value set in the **Power** input field.

The timing of when the regulation applies is set in the **Time** input fields and by selecting the **days of the week**.

It is not possible to define a time window beyond midnight (00:00).

Example: Two entries are needed to set a regulation of 22:00 to 06:00: "22:00 - 23:59" and "00:00 - 06:00".

Service Mode

If **Service Mode** is activated, the battery system is charged or discharged to the state of charge of 30% and the state of charge of 30% is maintained until the end of the service mode.

IMPORTANT!

The **Service Mode** is only available for Fronius battery systems.

Examples - Time-dependent battery control

The following examples serve to explain the energy flows. Efficiency levels are not taken into account.

Battery system

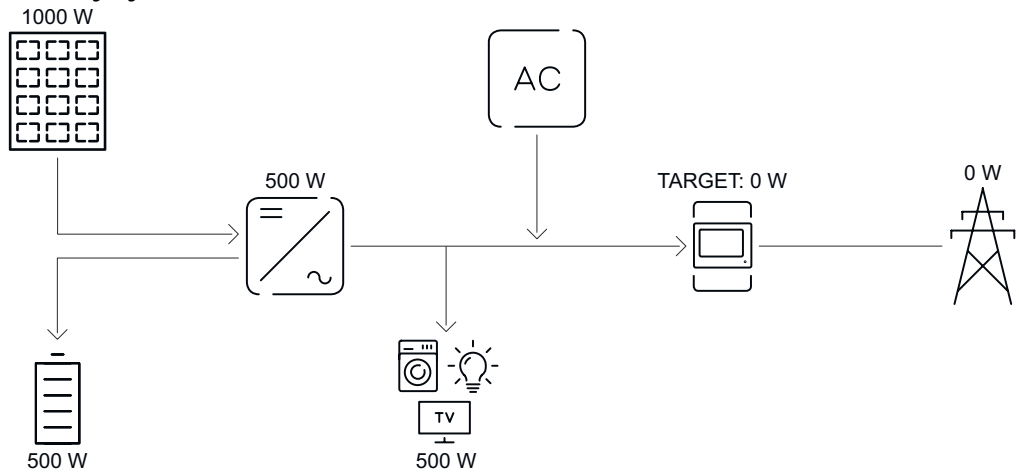

PV system to inverter	1000 W
Power into the battery	500 W
Power output (AC) of the inverter	500 W
Set target value at feed-in point	0 W
Infeed into the public grid	0 W
Consumption in home	500 W

Battery system without photovoltaics, including second generator in the house

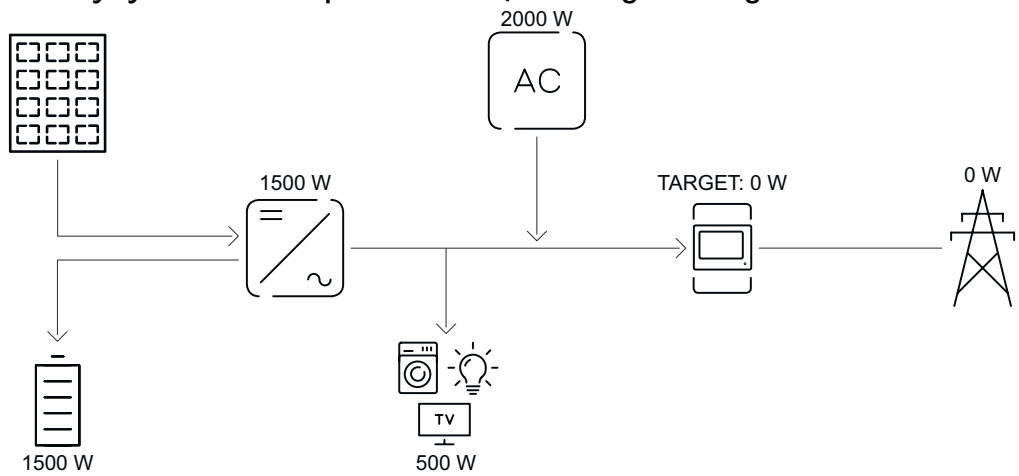

Power into the battery	1500 W
Power consumption (AC) of the inverter	1500 W
Second generator in home network	2000 W
Set target value at feed-in point	0 W
Infeed into the public grid	0 W
Consumption in home	500 W

Battery system including second generator in the house

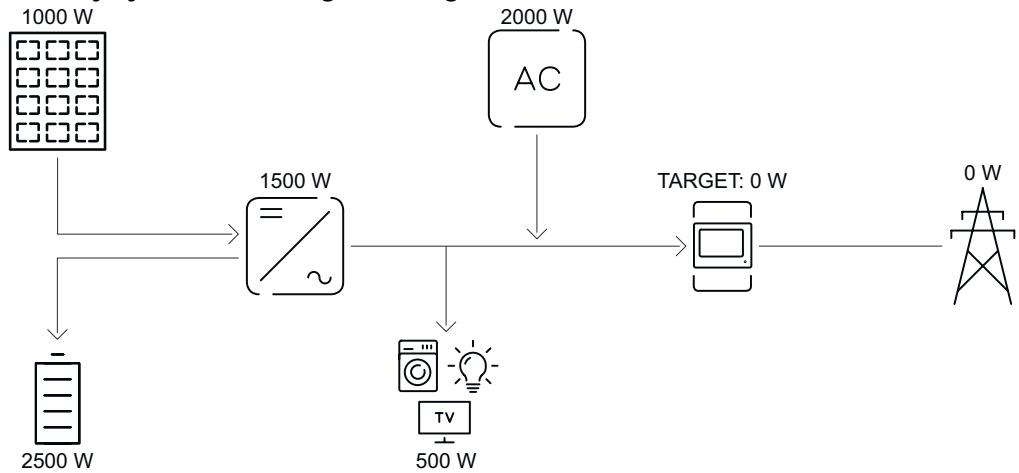

PV system to inverter	1000 W
Power into the battery	2500 W
Power consumption (AC) of the inverter	1500 W
Second generator in home network	2000 W
Set target value at feed-in point	0 W
Infeed into the public grid	0 W
Consumption in home	500 W

Permitted battery control regulations

A regulation always consists of a restriction or specification, and the **time** and **days of the week** when the regulation is active. The time of regulations with the same restriction (e.g., max. charging power) must not overlap.

Max. charging and discharging limits

One max. charging and one max. discharging power can be configured at the same time.

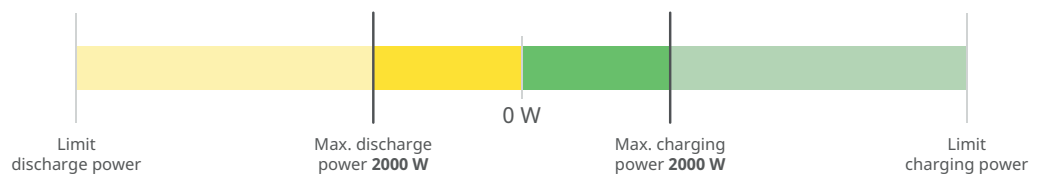

1.	Max. charging power	2000 W	00:00 - 23:59	Mo Tu We Th Fr Sa Su			<input checked="" type="checkbox"/>	
2.	Max. discharging power	2000 W	00:00 - 23:59	Mo Tu We Th Fr Sa Su			<input checked="" type="checkbox"/>	

Specify charging range

It is possible to define a charging range using a min. and max. charging limit. In this case, it is not possible to discharge the battery.

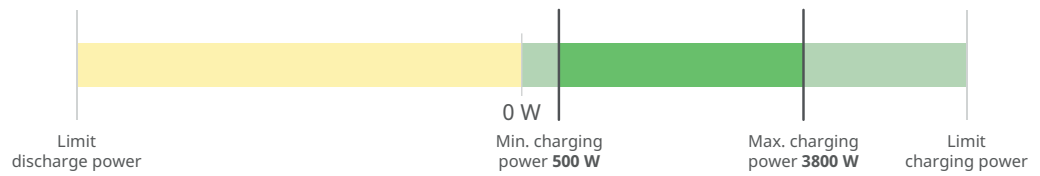

- | | | | | | | | | |
|----|---------------------|--------|---------------|----------------------|--|--|-------------------------------------|---|
| 1. | Min. charging power | 500 W | 03:00 – 04:00 | Mo Tu We Th Fr Sa Su | | | <input checked="" type="checkbox"/> | ▼ |
| 2. | Max. charging power | 3800 W | 03:00 – 04:00 | Mo Tu We Th Fr Sa Su | | | <input checked="" type="checkbox"/> | ▼ |

Specify discharging range

It is possible to define a discharging range using a min. and max. discharging limit. In this case, it is not possible to charge the battery.

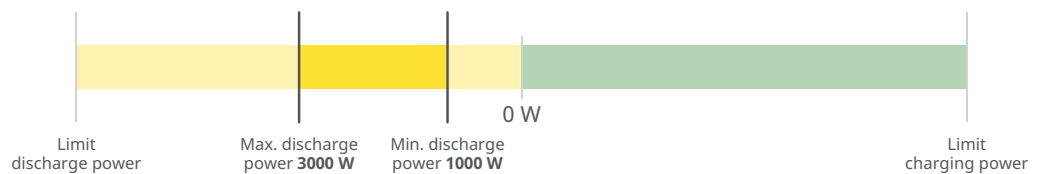

- | | | | | | | | | |
|----|------------------------|--------|---------------|----------------------|--|--|-------------------------------------|---|
| 1. | Max. discharging power | 3000 W | 13:00 – 14:00 | Mo Tu We Th Fr Sa Su | | | <input checked="" type="checkbox"/> | ▼ |
| 2. | Min. discharging power | 1000 W | 00:00 – 23:59 | Mo Tu We Th Fr Sa Su | | | <input checked="" type="checkbox"/> | ▼ |

Specify a defined charge

It is possible to specify a defined charging power by setting the min. and max. charging power to the same value.

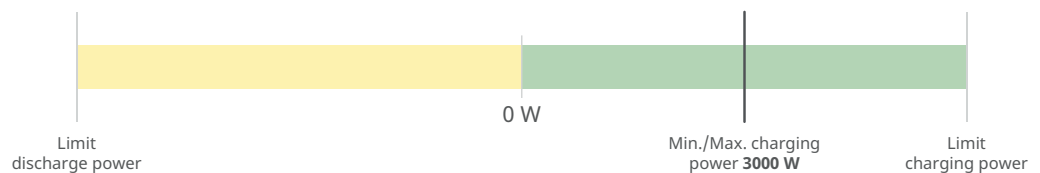

- | | | | | | | | | |
|----|---------------------|--------|---------------|----------------------|--|--|-------------------------------------|---|
| 1. | Min. charging power | 3000 W | 03:00 – 04:00 | Mo Tu We Th Fr Sa Su | | | <input checked="" type="checkbox"/> | ▼ |
| 2. | Max. charging power | 3000 W | 03:00 – 04:00 | Mo Tu We Th Fr Sa Su | | | <input checked="" type="checkbox"/> | ▼ |

Specify a defined discharge

It is possible to specify a defined discharging power by setting the min. and max. discharging power to the same value.

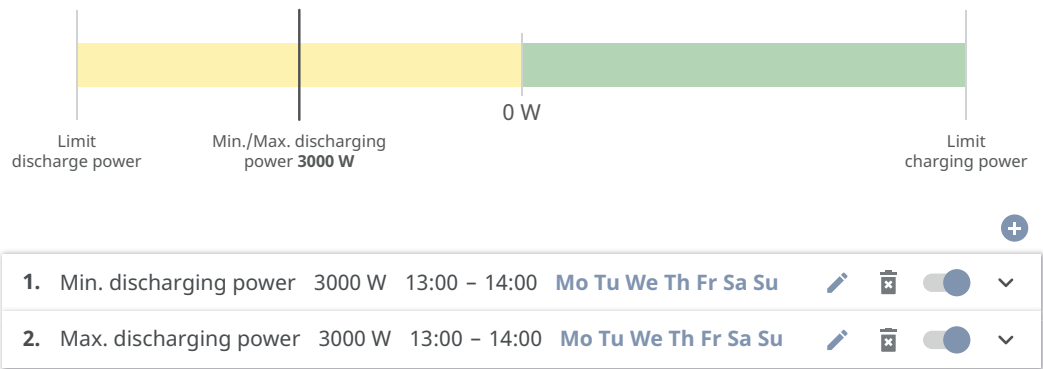

Possible applications

- Time-dependent energy tariffs
- Battery reservation in the event of market-specific power limitation
- Time-dependent storage reservation for a backup power situation

PV power reduction

The regulations in the **Battery Management** menu area enable optimal use of the energy generated. Situations may arise, in which PV power is not used in full due to the time-dependent battery control.

Example	
Fronius inverter (max. output power)	6000 W
Defined discharge of the battery	6000 W
PV power	1000 W

In this case, the inverter would have to reduce the PV power to 0 W, since the output power of the inverter is max. 6000 W and the device is already being fully utilized through discharging.

The power control with battery management is automatically adjusted such that no PV power is lost. In this example, the inverter reduces the discharging of the battery to 5000 watts. The 1000 W photovoltaic power is used in this way.

Load management

Priorities

If additional components (e.g., battery, Fronius Ohmpilot) are present in the system, the priorities can be set here. Devices having higher priority are actuated first, and subsequently, if there is still excess energy available, the other devices.

IMPORTANT!

If there is a Fronius Wattpilot in the photovoltaic system, it is considered to be a load. The priority for the load management of the Fronius Wattpilot must be configured in the Fronius Solar.wattpilot app.

Rules

It is possible for up to four different load management rules to be defined. At the same threshold values, the rules are activated in succession. For deactivation, this is done in reverse; the I/O last switched on is the first to be switched off. In the case of different thresholds, the I/O with the lowest threshold is switched on first, followed by the second lowest, and so on.

I/Os controlled by the produced power are always prioritized over a battery and Fronius Ohmpilot. That is to say that an I/O can switch on and result in the battery no longer being charged or the Fronius Ohmpilot no longer being activated.

IMPORTANT!

An I/O is activated/deactivated after 60 seconds.

Load

- Control is **Off** (deactivated).
- Control is effected by the **Power Production**.
- Control is effected by **Power Surplus** (with feed-in limits). This option can only be selected if a meter has been connected. Control is effected using the actual power of feeding in with respect to the grid.

Thresholds

- **On:** For entering an effective power limit, at which the output is activated.
- **Off:** For entering an effective power limit, at which the output is deactivated.

Duration

- Field for activating the **Minimum duration per on-signal** for which the output is to be activated for each switch-on process.
- Field for activating the **Maximum duration per day**.
- Field for activating the **Desired duration** for which the output is to be activated in total per day (several switch-on processes are allowed for).

Self-consumption optimization

Self-Consumption Optimization

Set the operating mode to **Manual** or **Automatic**. The inverter always adjusts to the set **Target value at feed-in point**. In **Automatic** operating mode (factory setting), an adjustment is made to 0 W at the feed-in point (max. self-consumption).

The **Target value at feed-in point** also applies if a further source feeds into this Smart Meter. In this case, however:

- The Fronius Smart Meter must be installed and configured at the feed-in point.
- The **Allow battery charging from other generators in the home network** function must be activated in the **Components > Battery** menu area.

Target value at feed-in point

If **Manual** has been selected under Self-Consumption Optimization, the **Operation Mode (Consumption/Feed-in)** and the **Target value at feed-in point** can be set.

IMPORTANT!

Self-Consumption Optimization has lower priority than **Battery Management**.

System

General

- 1 Enter the name of the system in the input field **PV System Name** (max. 30 characters).
 - 2 Select the **Timezone Region** and **Timezone Location** in the drop-down lists.
 - 3 Click **Save**.
- ✓ *System name, time zone, and time zone location are saved.*
-

Update

All available updates for inverters and other Fronius devices are provided on the product pages and in the "Fronius Download Search" area at www.fronius.com.

Update

- 1 Drag the firmware file into the **Drag & drop file here** field, or select via **Browse file**.
- ✓ *Update is started.*
-

Setup wizard

The guided setup wizard can be accessed here.

Restoring factory settings

All settings

Resets all configuration data, apart from the country setup. Changes to the country setup may only be made by authorized personnel.

All settings without network

Resets all configuration data, apart from the country setup and the network settings. Changes to the country setup may only be made by authorized personnel.

Event log

Current messages All current events of the linked system components are displayed here.

IMPORTANT!

Depending on the type of event, this must be confirmed via the "tick" button so that it can be further processed.

History

All events of the linked system components that are no longer present are displayed here.

Information

All the information regarding the system and the current settings is displayed and provided for download in this menu area.

License Manager

The power data and functional scope of the inverter are stored in the license file. If the inverter, power stage set PC board, or data communication area is replaced, the license file must also be replaced.

Licensing

Licensing - online (recommended)

This requires an Internet connection and a completed Fronius Solar.web configuration.

- 1 Finish all installation work (refer to the chapter headed [Closing the inverter's connection area/housing cover, and commissioning](#) on page 86).
- 2 Establish a connection to the user interface of the inverter.
- 3 Enter the serial number and verification code (VCode) of the defective and replacement device. The serial number and VCode can be found on the rating plate of the inverter (refer to the chapter headed [Information on the device](#) on page 18).
- 4 Click the **Start online licensing** button.
- 5 Skip past the Terms and conditions of use and Network settings menu items by clicking **Next**.

✓ *License activation is started.*

Licensing - offline

There must be no Internet connection in this case. If offline licensing is carried out while there is an active Internet connection, the license file is automatically loaded onto the inverter, resulting in the following error when the license file is uploaded: "The license has already been installed and the wizard can be closed".

- 1 Finish all installation work (refer to the chapter headed [Closing the inverter's connection area/housing cover, and commissioning](#) on page 86).
- 2 Establish a connection to the user interface of the inverter.
- 3 Enter the serial number and verification code (VCode) of the defective and replacement device. The serial number and VCode can be found on the rating plate of the inverter (refer to the chapter headed [Information on the device](#) on page 18).
- 4 Click the **Start offline licensing** button.
- 5 Download the service file onto the mobile device by clicking the **Download service file** button.
- 6 Open licensemanager.solarweb.com and log in with username and password.
- 7 Drag the service file into the **Drag service file here or click to upload** field or click to upload it.
- 8 Download the newly generated license file onto the mobile device by clicking the **Download license file** button.
- 9 Switch to the user interface of the inverter and drag the license file into the **Drag & drop license file here** field or select via **Choose license file**.

✓ *License activation is started.*

Support

Activating the support user

- 1 Click the **Enable Support User Account** button.

✓ *The support user is activated.*

IMPORTANT!

The support user exclusively enables Fronius Technical Support to configure settings on the inverter via a secure connection. Access is deactivated by clicking the **Terminate Support User Session** button.

Generating support info (for Fronius Support)

- 1** Click the **Generate support info** button.
- 2** The sdp.cry file is downloaded automatically. For manual download, click the **Download support info** button.

✓ *The sdp.cry file is saved in the downloads.*

Activating remote access

- 1** Click the **Activate Remote Access** button.

✓ *Remote access is activated for Fronius Support.*

IMPORTANT!

The remote access exclusively enables Fronius Technical Support to access the inverter via a secure connection. In this case, diagnostics data are transmitted, which are used for troubleshooting. The remote access can be activated only upon request by Fronius Support.

Communication

Network

Server addresses for data transfer

If a firewall is used for outgoing connections, allow the below protocols, server addresses, and ports for successful data transfer, see:

https://www.fronius.com/-/downloads/Solar%20Energy/Firmware/SE_FW_Changelog_Firewall_Rules_EN.pdf

When using FRITZ!Box products, configure Internet access without any restrictions or limitations. Do not set the DHCP Lease Time (validity) to 0 (=infinite).

LAN:



Establishing a connection:

- 1 Enter the host name.
- 2 Select the connection type: **Automatic** or **Static**.
- 3 For the **Static** connection type, enter the IP address, subnet mask, DNS, and gateway.
- 4 Click the **Connect** button.

✓ *The connection is established.*

After establishing the connection, check the connection status.

WiFi:



Establishing a connection via WPS:

- Activate the access point of the inverter. This is opened by touching the sensor  > Communications LED flashes blue
- 1 Establish the connection to the inverter in the network settings (the inverter is displayed with the name "FRONIUS_" and the serial number of the device).
 - 2 Enter the password from the rating plate and confirm.
IMPORTANT!
To enter the password, first select the **Connect using a security key instead** link in order to establish the connection with the password.
 - 3 Enter the IP address 192.168.250.181 in the address bar of the browser and confirm.
 - 4 In the **Communication > Network > WLAN > WPS** menu area, click the **Activate** button.
 - 5 Activate WPS on the WiFi router (see WiFi router documentation).
 - 6 Click on the **Start** button. The connection is established automatically.
 - 7 Log in to the user interface of the inverter.
 - 8 Check the network details and connection to Fronius Solar.web.

After connecting, the status of the connection should be checked.

Selecting and connecting to a WiFi network:

The networks found are displayed in the list. Click the refresh button  to perform a new search for available WiFi networks. If necessary, restrict the selection list further via the **Search network** input field.

- 1 Select network from the list.
- 2 Select the connection type: **Automatic** or **Static**.
- 3 For the **Automatic** connection type, enter the WiFi password and host name.
- 4 For the **Static** connection type, enter the IP address, subnet mask, DNS, and gateway.
- 5 Click the **Connect** button.

✓ *The connection is established.*

After establishing the connection, check the connection status.

Access point:



The inverter serves as the access point. A PC or mobile device connects directly to the inverter. Connecting to the Internet is not possible. Assign a **Network Name (SSID)** and **Network Key (PSK)** to establish a connection. Assign a **Network Key (PSK)** with at least 20 characters, consisting of upper and lower case letters, special characters, and numbers, to protect the device from unauthorized access.

It is possible to operate a connection via WiFi and via the access point at the same time.

Modbus

The inverter communicates with system components (e.g., Fronius Smart Meter) and other inverters via Modbus. The primary device (Modbus Client) sends control commands to the secondary device (Modbus Server). The control commands are executed by the secondary device.

RTU Server

The following input fields and functions are available for communication via Modbus RTU:

Meter address offset

The value entered (1-247) is the identification number (unit ID) assigned to the meter.

Factory setting: 200

Inverter address

The value entered (1-247) is the identification number (unit ID) assigned to the inverter.

Factory setting: 1

SunSpec Model Type

There are two different settings, depending on the SunSpec model.

float: SunSpec Inverter Model 111, 112, 113 or 211, 212, 213.

int + SF: SunSpec Inverter Model 101, 102, 103 or 201, 202, 203.

Interface

Select one of the two interfaces **Modbus 0 (M0) RTU** or **Modbus 1 (M1) RTU**.

Baud Rate

The baud rate influences the speed of the transmission between the individual components connected in the system. When selecting the baud rate, it should be ensured that this is the same on the transmit and receive side.

Parity

The parity bit can be used for parity checks. This is used to identify transmission errors. In this case, a parity bit can ensure a specified number of bits. The value (0 or 1) of the parity bit must be calculated at the transmitter, and is checked at the receiver using the same calculation. The calculation of the parity bit can be carried out for even or odd parity.

Allow Control

If this option is activated, the inverter is controlled via Modbus. Inverter control includes the following functions:

- On/off
 - Power reduction
 - Setting a constant power factor (cos phi)
 - Setting a constant reactive power
 - Battery control settings with battery
-

TCP Server

The following input fields and functions are available for communication via Modbus TCP:

Meter address offset

The value entered (1-247) is the identification number (unit ID) assigned to the meter.

Factory setting: 200

SunSpec Model Type

There are two different settings, depending on the SunSpec model.

float: SunSpec Inverter Model 111, 112, 113 or 211, 212, 213.

int + SF: SunSpec Inverter Model 101, 102, 103 or 201, 202, 203.

Modbus port

Number of the TCP port (502 or 1502) to be used for Modbus communication.

Meter Address

The value entered is the identification number (unit ID) assigned to the meter, which can be found on the user interface of the inverter in the **Communication > Modbus** menu area.

Factory setting: 200

Allow Control

If this option is activated, the inverter is controlled via Modbus. Inverter control includes the following functions:

- On/off
 - Power reduction
 - Setting a constant power factor (cos phi)
 - Setting a constant reactive power
 - Battery control settings with battery
-

Restrict Control

Restrict the control of the inverter to a device with a fixed IP address.

Cloud control

The utility/energy supplier can influence the output power of the inverter with **Cloud control**. This requires the inverter to have an active Internet connection.

Parameter	Display	Description
Cloud control	Off	Cloud control of the inverter is deactivated.
	On	Cloud control of the inverter is activated.

Profile	Value range	Description
Allow cloud control for regulatory purposes (Technician)	Deactivated/ Activated	The function may be mandatory for proper operation of the system.*
Allow cloud control for Virtual Power Plants (Customer)	Deactivated/ Activated	If the Allow remote control for regulatory purposes (technician) function is activated (technician access required), the Allow remote control for virtual power plants function is automatically activated and cannot be deactivated.*

*** Cloud control**

A virtual power plant is an interconnection of multiple generators. This virtual power plant can be controlled by means of the cloud control via the Internet. An active inverter Internet connection is a prerequisite for this. System data are transferred.

Solar API

The **Solar API** is an IP-based, open JSON interface. If enabled, IOT devices in the local network may access inverter information without authentication. For security reasons, the interface is disabled in the factory. Activate the interface manually if it is required for a third-party application (e.g., EV charger, smart home solutions, etc.). If there is a Fronius Wattpilot in the network, the inverter automatically activates the **Solar API**.

Fronius recommends using Fronius Solar.web for monitoring and analyzing the inverter and connected system components.

In the event of a firmware update to version 1.14.x, the Solar API setting is applied. In systems with a version below 1.14.x, the Solar API is activated; with higher versions, it is deactivated but can be switched on and off via the menu.

Manually activating the Fronius Solar API

On the user interface of the inverter in the **Communication > Solar API** menu area, activate the function **Activate communication via Solar API**.

Fronius Solar.web

In this menu, you can agree to the technically necessary data processing or reject it.

In addition, the transfer of analysis data and remote configuration via Fronius Solar.web can be enabled or disabled.

Safety and grid requirements

Country setup

WARNING!

Danger from unauthorized fault analyses and repair work.

This can result in serious injury and damage to property.

- ▶ Fault analyses and repair work on the PV system may only be carried out by installers/service technicians from authorized specialist companies in accordance with national standards and regulations.

NOTE!

Risk due to unauthorized access.

Incorrectly set parameters can have a negative effect on the public grid and/or the grid power feed operation of the inverter and result in the loss of standard conformity.

- ▶ Parameters may only be adjusted by installers/service technicians from authorized specialist companies.
- ▶ Do not give the access code to third parties and/or unauthorized persons.

NOTE!

Risk due to incorrectly set parameters.

Incorrectly set parameters can have a negative effect on the public grid and/or cause inverter malfunctions and failures and result in the loss of standard conformity.

- ▶ Parameters may only be adjusted by installers/service technicians from authorized specialist companies.
- ▶ Parameters may only be adjusted if this has been approved or requested by the utility.
- ▶ Any parameter adjustments must be made in compliance with nationally applicable standards and/or directives as well as the specifications of the utility.

The **Country Setup** menu area is intended exclusively for installers/service technicians from authorized specialist companies. To apply for the access code required for this menu area, see chapter [Requesting inverter codes in Solar.SOS](#).

The selected country setup for the country in question contains preset parameters in accordance with nationally applicable standards and requirements. Changes may need to be made to the selected country setup depending on local grid conditions and the specifications of the utility.

Requesting inverter codes in Solar.SOS

The **Country Setup** menu area is intended exclusively for installers/service technicians from authorized specialist companies. The inverter access code required for this menu area can be requested in the Fronius Solar.SOS portal.

Requesting inverter codes in Fronius Solar.SOS:

- 1 Open solar-sos.fronius.com in the browser
- 2 Log in with your Fronius account
- 3 At the top right, click on the drop-down menu 

- 4 Select the **Show inverter codes** menu item
 - ✓ *A contract page appears on which the request for the access code to change the grid parameters for Fronius inverters is located*
- 5 Accept the terms and conditions of use by checking **Yes, I have read and agree to the terms of use** and click **Confirm & Save**
- 6 After that, the codes can be retrieved in the drop-down menu at the top right under **Show inverter codes**



CAUTION!

Risk due to unauthorized access.

Incorrectly set parameters can have a negative effect on the public grid and/or the grid power feed operation of the inverter and result in the loss of standard conformity.

- ▶ Parameters may only be adjusted by installers/service technicians from authorized specialist companies.
- ▶ Do not give the access code to third parties and/or unauthorized persons.

Absolute Generation Limit

Activating this function limits the output power of the inverter to the specified value in watts.

Import limitation

Energy companies or grid operators can prescribe import limitations for inverters. The amperage is limited to the set value.

- 1 Under **Limit** select **Current Limitation**.
- 2 Enter the **limit value** in amperes.
- 3 Click on **Save**.

Feed-in limit

Energy companies or grid operators can prescribe feed-in limits for inverters (e.g., max. 70% of the kWp or max. 5 kW). The effective power at the grid connection point (installation location of the Fronius Smart Meter or primary meter) is limited to the set value.

The feed-in limit takes account of self-consumption in the household before the power of an inverter is reduced. An individual limit can be set.

In order to minimize the yield losses due to the power of feeding in limitation, the power available from the module array can be:

- Stored in a battery
- Used for controllable system components, such as Fronius Ohmpilot or Fronius Wattpilot
- Used by loads controlled via I/Os

If these possibilities have been exhausted, the power drawn from the module array is reduced to such an extent that the feed-in limit is not exceeded.

Installation variants with an inverter, Fronius Smart Meter, and system components are listed under [Different operating modes](#).

Total DC power of the system

The input field for the total DC power of the entire system in Wp. Always enter this value if the **Maximum grid feed-in power** is specified in %.

Power Control deactivated

The inverter converts all available PV energy.

Power Control activated

Feeding in limited with the following selection options:

- **Total Power Limit**
Set the value of the permissible total power of feeding in for the photovoltaic system.
- **Limit per phase - asymmetric generation**
The inverter determines the optimum per phase. The inverter regulates the individual phases in such a way that none of the phases exceeds the set value.
- **Limit per phase - weakest phase**
The inverter measures each individual phase. If the permissible feed-in limit is exceeded on one phase, the inverter symmetrically reduces the total power for all phases until the limit is reached.

IMPORTANT!

Implement the settings for **Limit per phase** if national standards and regulations require a limitation of the single-phase power. Set the value for the permissible power of feeding in for each phase.

IMPORTANT!

Power Control settings are automatically applied for the dynamic feed-in limit of I/O power management. **Total Power Limit** is the default configuration.

Dynamic feed-in limit (Soft Limit)

If this value is exceeded, the inverter readjusts down to the set value.

Export Limit Protection (Hard Limit Trip)

IMPORTANT!

This function is only available if **Dynamic feed-in limit (Soft Limit)** is activated.

Maximum grid feed-in power

Input field for the **Maximum grid feed-in power** in W or % (setting range: -10 % to 100 %).

If there is no meter in the system or if the primary meter has failed, the inverter limits its output power to the set value.

If this value is exceeded, the inverter switches off within max. 5 s. This value must be higher than the value set for **Power Control (Soft Limit)**.

Enable the fail-safe function **Reduce inverter power to 0% if meter connection has been lost**. When this function is enabled, the inverter activates standby mode. No feed-in takes place.

The use of WiFi for communication between the Fronius Smart Meter and the inverter is not recommended for the fail-safe function. Even short-term disconnections can cause the inverter to shut down. This problem arises with weak WiFi signal strengths, a slow or overloaded WiFi connection, and automatic channel selection of the router.

Feed-in limit - examples

Total Power Limit

(feed-in limit 0 kW with battery)

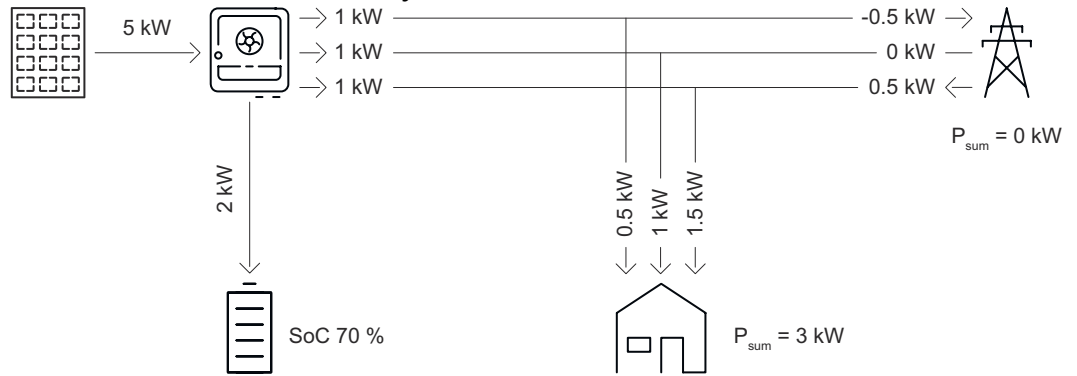

Explanation

No power (0 kW) may be fed into the public grid at the grid feed-in point. The load requirement in the home network (3 kW) is supplied by the power generated by the inverter. Surplus production (2 kW) is stored in the battery.

Limit per phase - asymmetric generation

(feed-in limit 0 kW per phase) - asymmetric

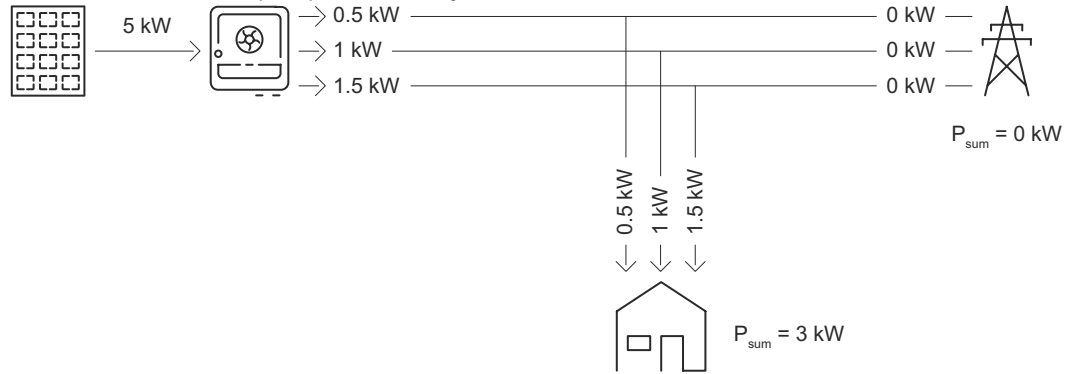

Explanation

The load requirement in the home network per phase is determined and supplied.

Limit per phase - asymmetric generation

(feed-in limit 0 kW per phase with battery) - asymmetric

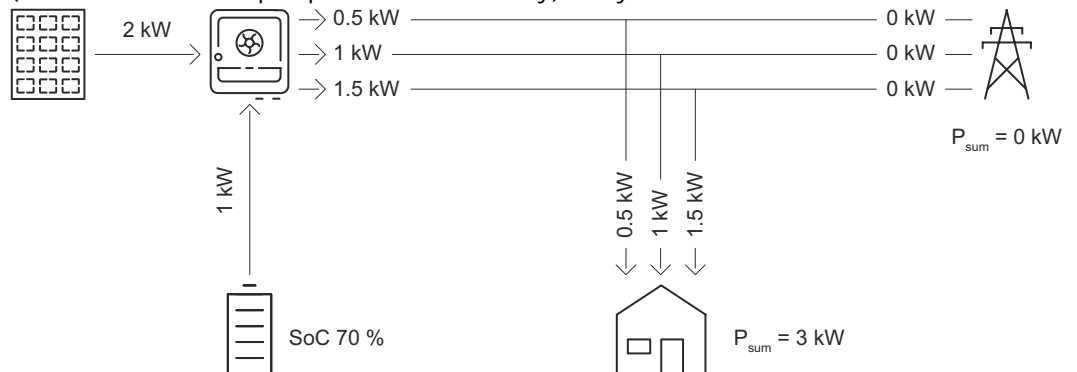

Explanation

The load requirement in the home network per phase is determined and supplied. Additional power required (1 kW) is provided by the battery.

Limit per phase - weakest phase

(feed-in limit 0 kW per phase with battery) – symmetrical

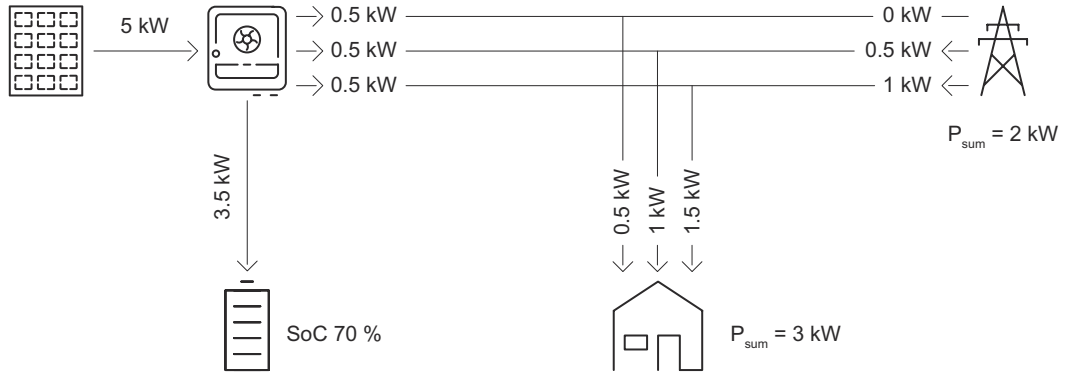

Explanation

The weakest phase in the load requirement in the home network is determined (phase 1 = 0.5 kW). The result of the weakest phase (0.5 kW) is applied to all phases. Phase 1 (0.5 kW) can be supplied. Phase 2 (1 kW) and phase 3 (1.5 kW) cannot be supplied, power from the public grid is required (phase 2 = 0.5 kW, phase 3 = 1 kW). Surplus production (3.5 kW) is stored in the battery.

Multiple Inverter Control

IMPORTANT!

To view and change settings in this menu item, select the **Technician** user. Enter and confirm the password for the **Technician** user. Settings in this menu area may only be made by trained and qualified personnel.

The inverter can be used as a primary device to control dynamic feed-in limits for additional Fronius inverters (secondary devices) so that feed-in limits prescribed by energy companies or utilities can be centrally managed. This control refers to the **Soft Limit** feed-in limit see [Feed-in limit](#). To do so, the following requirements must be met:

- A Fronius Smart Meter is configured as a primary meter and connected to the master.
- **Power Control** is activated and configured in the **feed-in limit** menu on the user interface of the primary device. The power control limit is set to **Total Power Limit**.
- Master and secondary device(s) are physically connected to the same network router via LAN.
- If **Use Modbus SunSpec instead of MQTT** is enabled, the inverter control via Modbus TCP must be activated and configured for all secondary devices.

IMPORTANT!

Only one primary meter is required for the primary device.

IMPORTANT!

If an inverter with a battery is connected, use this inverter as the primary device for **Multiple Inverter Control**.

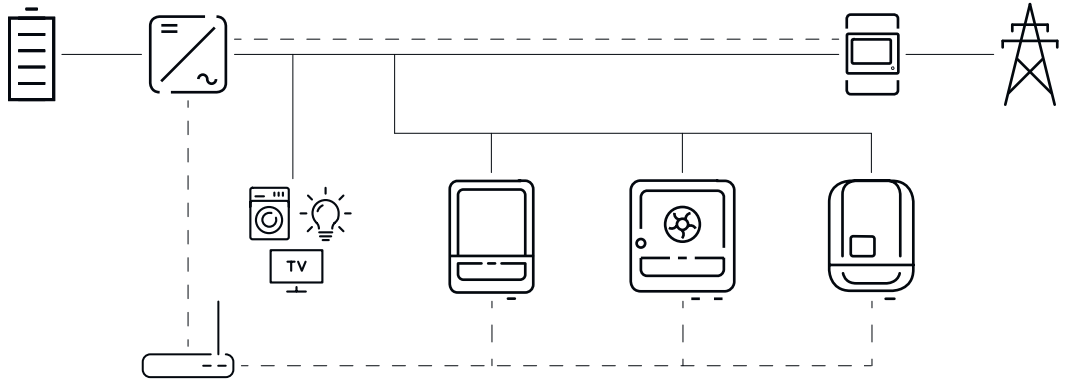

Example connection diagram for Multiple Inverter Control

System limits

- Systems with a maximum of 20 inverters (1 primary device + 19 secondary devices) are supported if the **Use Modbus SunSpec instead of MQTT** function is activated. Otherwise, a maximum of one primary device and two secondary devices are supported.
- The control system is designed for photovoltaic systems with a total output of up to 300 kW.
- In the case of larger system capacities, the control times in the system are extended.
- The use of a plant controller is recommended for systems >300 kW.

Multiple Inverter Control is available for the following device combinations:

Primary devices	Secondary devices
GEN24, Verto, Tauro	<ul style="list-style-type: none"> - GEN24 - Verto - Tauro - Argeno - SnapINverter with Fronius Datamanager 2.0*

* Up to four additional SnapINverters can be connected to each SnapINverter with Fronius Datamanager 2.0.

Primary meter

One Fronius Smart Meter acts as the only primary meter and is connected directly to the primary device. This Smart Meter measures the total output power of all inverters into the grid and passes this information to the primary device.

Primary device

Configure the feed-in limit on the user interface of the inverter:

- 1 In the **Safety and Grid Regulations > Feed-in limit** menu area, activate the **Power Control** function and Select **Total Power Limit**.
- 2 Configure the country-specific settings.
- 3 In the **Safety and Grid Regulations > Multiple Inverter Control** menu area, activate the **Multiple Inverter Control** function.
The primary device automatically scans the network for available secondary devices.
✓ A list shows the inverters found.

To perform the search again, press the Refresh button .

If **Use Modbus SunSpec instead of MQTT** is activated, it is also possible to select SnapINverter with Datamanager 2.0 and Fronius Argeno with **Use Inverter**.

Multiple Inverter Control

Control other Inverters

Use Modbus SunSpec instead of MQTT

Detected Inverters

Additional Inverters

30 Inverters were found 

Status	Name ↓	Device Type	Serial number	Hostname	IP Address	Use Inverter
Inactive	tr-3pn-official-22	Fronius Symo GEN24 10.0	30427997	tr-3pn-official-22.local	10.4.89.51	<input type="checkbox"/>
Inactive	tr-3p5-32	Fronius Symo GEN24 5.0-31587468	31587468	tr-3p5-32.local	10.4.89.30	<input type="checkbox"/>
Inactive	tr-3p10-10	Fronius Symo GEN24 Plus 10.0-29395866	29395866	tr-3p10-10.local	10.4.89.6	<input type="checkbox"/>

- 4** Activate **Use Inverter** against all secondary devices to which a common feed-in limit applies. Click **Use all inverters** to enable the function for the primary device and all secondary devices.

The status of the inverters listed is displayed as follows:

- **Inactive:** Secondary device is not configured for the power control or a firmware update is required.
- **Disconnected:** Secondary device is configured, network connection not possible.
- **Connected:** Secondary device is configured and accessible via the network of the primary device.

- 5** In the **Safety and Grid Regulations > I/O Power Management** menu area, set the controlling priorities as follows:
1. **I/O Power Limit**
 2. **Feed-in limit**
 3. **Modbus Control**

Adding Fronius Argeno and other inverters manually

- 1** In the **Multiple Inverter Control** menu, select the **Multiple Inverter Control** function.
- 2** Select additional inverters and click **+ Add**.
- 3** Enter the name, hostname or IP address, and the Modbus address of the secondary device.
- 4** Click **Add**.

For more information on configuring the Fronius Argeno or Fronius Dataman-ager 2.0 as a secondary device, refer to the respective operating instructions.

Secondary device

Each secondary device takes over the settings for the feed-in limit from the primary device. A secondary device does not transmit any data for the feed-in limit to the primary device. To do so, the following requirements must be met:

- **Multiple Inverter Control** is activated and configured in the **Multiple Inverter Control** menu on the user interface of the primary device.

Set the following configurations for the feed-in limit on the secondary device:

User interface secondary device GEN24 / Verto / Tauro

- 1** Select the user **Technician** and enter the password for the user **Technician**.

Only carry out work steps 2 and 3 if **Use Modbus SunSpec instead of MQTT** is activated on the primary device.

- 2** In the **Communication > Modbus** menu area, activate the **TCP Server** mode and the **Allow Control** function.

- 3** For a fail-safe scenario, in the **Safety and Grid Regulations > I/O Power Management** menu area, set the controlling priorities as follows:
1. **Modbus Control**
 2. **Feed-in limit**
 3. **I/O Power Limit**
- 4** In the **Safety and Grid Regulations > Feed-in limit** menu area, select and edit the following settings:
- Enable the **Power Control** function.
 - Select **Total Power Limit** and specify the **Total DC power of the system** in watts.
 - Activate the **Dynamic feed-in limit (Soft Limit)** and enter a value of 0 W for the **Max. grid feed-in power**.
 - Enable the **Reduce inverter power to 0% if meter connection has been lost** function.

I/O Power Management

General

Settings relevant to the grid operator are defined as rules under this menu item. This relates to an effective power limit in % or watts and/or a power factor specification.

IMPORTANT!

To view and change settings in this menu item, select the user **Technician**, and enter and confirm the password for the user **Technician**. Only technical specialists may make settings in this menu area.

Under **Rules**, expand a menu area (e.g., **Rule 1**). Configure the following settings:

Limitation

IMPORTANT!

A dynamic feed-in limit for several inverters can be configured under [Feed-in limit](#). I/O power management rules are transferred from the inverter (primary device) to connected inverters in the system (secondary devices).

Select the following rules for power management:

- **I/O Generation Limit (%)**: The total output power of the connected inverter is statically limited to the defined value of the absolute rated power.
- **Export Limit Control (W)**: The effective power fed in at the grid connection point is limited to the set value (e.g., 5000 watts). The output powers of the inverters (primary and secondary devices) are dynamically adjusted depending on their self-consumption.
- **Shutdown single device**: The inverter stops grid power feed operation and switches to standby mode.

IMPORTANT!

The rules for shutdown apply to this device and cannot be applied to other inverters in the system.

Input pattern (assignment of individual I/Os)

- 1 click = white, contact open
- 2 clicks = blue, contact closed
- 3 clicks = gray, not used

Power Factor (cos φ) (define value)

Impedance response

- **Capacitive**
- **Inductive**

DNO Feedback

If the rule is activated, always configure the **DNO Feedback** output, e.g., for operating a signal device.

The **Import** and **Export** of defined rules can be carried out in the data format *.fpc.

If there is an active rule for the control of the inverter, the device indicates this in the **overview** of the user interface under **Device State**.

Controlling Priorities

Used to set controlling priorities for I/O Power Management (DRM or ripple control receiver), the feed-in limit, and control via Modbus.

1 = highest priority, 3 = lowest priority

Local priorities of the I/O Power Management, the feed-in limit, and the Modbus interface are deactivated by cloud control commands (regulatory purposes and virtual power plants) – see [Cloud control](#) on page 114 – and by backup power.

In terms of control priorities, the device differentiates between **power control** and **inverter shutdown**. Inverter shutdown always takes precedence over power control. An inverter shutdown command is always executed and does not need to be prioritized.

Power control

- I/O Power Management (DRM/ripple control receiver signal)—according to command
- Export Limitation (Soft Limit)—always active
- Modbus (generation limit)—according to command

Inverter shutdown

- Shutdown single device
- Export Limitation (Hard Limit)
- Modbus (shutdown command) – according to command

Connection diagram - 4 relays

Connect the ripple control signal receiver and the I/O terminals of the inverter to one another as shown in the connection diagram.

For distances greater than 10 m between the inverter and the ripple control signal receiver, use a shielded data communication cable (CAT 5 or higher) with twisted cable pairs. Connect the shielding on one side to the push-in terminal of the data communication area (SHIELD).

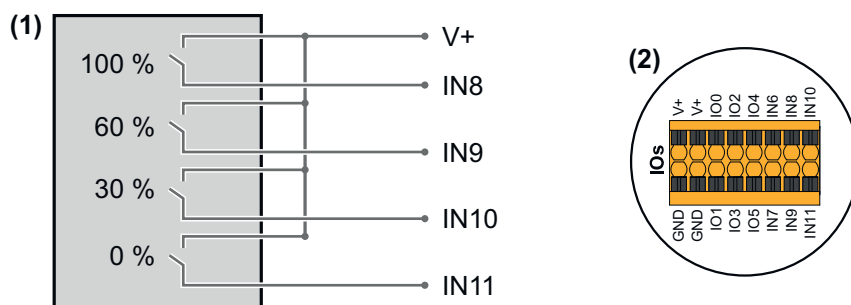

- (1) Ripple control signal receiver with 4 relays for effective power limitation.
- (2) I/O connection terminals of the data communication area.

Use pre-configured file for 4-relay operation:

- 1** Download the file (.fpc) under [4-relay operation](#) to the mobile device.
 - 2** Upload the file (.fpc) in the **I/O Power Management** menu area by clicking the **Import** button.
 - 3** Click **Save**.
- ✓ *The settings for 4-relay operation are saved.*

I/O power management settings - 4 relays

I/O Power Management



DNO feedback pin
Not used

Rules + Add

Rule 1

0 2 4 6 8 10
1 3 5 7 9 11

Limitation
I/O Generation Limit (%)

Active Power * 100 %

Power Factor (cos φ) * 1 Impedance response Capacitive

DNO Feedback

Rule 2

0 2 4 6 8 10
1 3 5 7 9 11

Limitation
I/O Generation Limit (%)

Active Power * 60 %

Power Factor (cos φ) * 1 Impedance response Capacitive

DNO Feedback

Rule 3

0 2 4 6 8 10
1 3 5 7 9 11

Limitation
I/O Generation Limit (%)

Active Power * 30 %

Power Factor (cos φ) * 1 Impedance response Capacitive

DNO Feedback

Rule 4

0 2 4 6 8 10
1 3 5 7 9 11

Limitation
I/O Generation Limit (%)

Active Power * 0 %

Power Factor (cos φ) * 1 Impedance response Capacitive

DNO Feedback

Import Export

- 0 Activate Backup interlock
- 1 Rule 1
- 2 None
- 3 None
- 4 None
- 5 None
- 6 Open grid relais feedback
- 7 Backup interlock feedback
- 8 I/O control
- 9 I/O control
- 10 I/O control
- 11 I/O control

Connection diagram - 3 relays

Connect the ripple control signal receiver and the I/O terminals of the inverter to one another as shown in the connection diagram. For distances greater than 10 m between the inverter and the ripple control signal receiver, use a shielded data communication cable (CAT 5 or higher) with twisted cable pairs. Connect the shielding on one side to the push-in terminal of the data communication area (SHIELD).

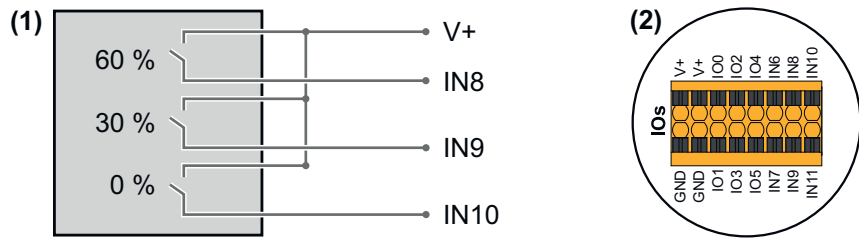

- (1) Ripple control signal receiver with 3 relays for effective power limitation.
- (2) I/O connection terminals of the data communication area.

Use pre-configured file for 3-relay operation:

- 1** Download the file (.fpc) under [3-relay operation](#) to the mobile device.
- 2** Upload the file (.fpc) in the **I/O Power Management** menu area by clicking the **Import** button.
- 3** Click **Save**.

✓ *The settings for 3-relay operation are saved.*

I/O power management settings - 3 relays

I/O Power Management

V+/GND I/O I

DNO feedback pin
Not used

Rules + Add

Rule 1

0 2 4 6 8 10
1 3 5 7 9 11

Limitation
I/O Generation Limit (%)

Active Power * 100 %

Power Factor (cos φ) * 1 Impedance response Capacitive

DNO Feedback

Rule 2

0 2 4 6 8 10
1 3 5 7 9 11

Limitation
I/O Generation Limit (%)

Active Power * 60 %

Power Factor (cos φ) * 1 Impedance response Capacitive

DNO Feedback

Rule 3

0 2 4 6 8 10
1 3 5 7 9 11

Limitation
I/O Generation Limit (%)

Active Power * 30 %

Power Factor (cos φ) * 1 Impedance response Capacitive

DNO Feedback

Rule 4

0 2 4 6 8 10
1 3 5 7 9 11

Limitation
I/O Generation Limit (%)

Active Power * 0 %

Power Factor (cos φ) * 1 Impedance response Capacitive

DNO Feedback

Import Export

- 0 Activate Backup interlock
- 1 Rule 1
- 2 None
- 3 None
- 4 None
- 5 None
- 6 Open grid relais feedback
- 7 Backup interlock feedback
- 8 I/O control
- 9 I/O control
- 10 I/O control
- 11 None

Connection diagram - 2 relays

Connect the ripple control signal receiver and the I/O terminals of the inverter to one another as shown in the connection diagram.
For distances greater than 10 m between the inverter and the ripple control sig-

nal receiver, use a shielded data communication cable (CAT 5 or higher) with twisted cable pairs. Connect the shielding on one side to the push-in terminal of the data communication area (SHIELD).

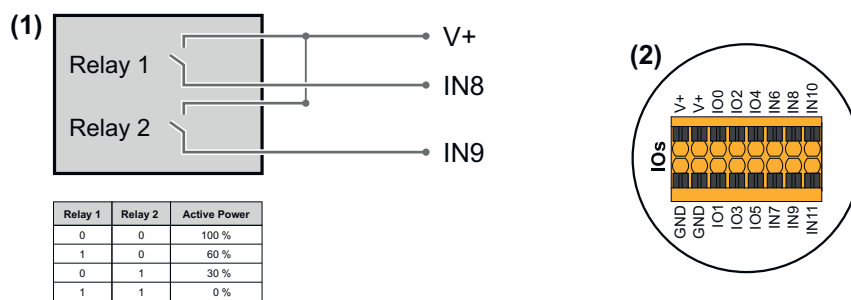

- (1) Ripple control signal receiver with 2 relays for effective power limitation.
- (2) I/O connection terminals of the data communication area.

Use pre-configured file for 2-relay operation:

- 1 Download the file (.fpc) under [2-relay operation](#) to the mobile device.
 - 2 Upload the file (.fpc) in the **I/O Power Management** menu area by clicking the **Import** button.
 - 3 Click **Save**.
- ✓ *The settings for 2-relay operation are saved.*

I/O power management settings - 2 relays

I/O Power Management



DNO feedback pin
Not used

Rules + Add

Rule 1

Limitation
I/O Generation Limit (%)

Active Power * 100 %

Power Factor (cos φ) * 1 Impedance response Capacitive

DNO Feedback

Rule 2

Limitation
I/O Generation Limit (%)

Active Power * 60 %

Power Factor (cos φ) * 1 Impedance response Capacitive

DNO Feedback

Rule 3

Limitation
I/O Generation Limit (%)

Active Power * 30 %

Power Factor (cos φ) * 1 Impedance response Capacitive

DNO Feedback

Rule 4

Limitation
I/O Generation Limit (%)

Active Power * 0 %

Power Factor (cos φ) * 1 Impedance response Capacitive

DNO Feedback

Import Export

- 0 Activate Backup interlock
- 1 Rule 1
- 2 None
- 3 None
- 4 None
- 5 None
- 6 Open grid relais feedback
- 7 Backup interlock feedback
- 8 I/O control
- 9 I/O control
- 10 None
- 11 None

Connection diagram - 1 relay

The ripple control signal receivers and the I/O terminals of the inverter can be connected to one another as shown in the connection diagram. For distances of over 10 m between the inverter and the ripple control signal receiver, a CAT 5 STP cable is recommended as a minimum and the shielding must be connected on one side at the push-in terminal of the data communication area (SHIELD).



- (1) Ripple control signal receiver with 1 relay for effective power limitation.
- (2) I/O connection terminals of the data communication area.

Use pre-configured file for 1-relay operation:

- 1** Download the file (.fpc) under [1-relay operation](#) to the mobile device.
 - 2** Upload the file (.fpc) in the **I/O Power Management** menu area by clicking the **Import** button.
 - 3** Click **Save**.
- ✓ *The settings for 1-relay operation are saved.*

I/O power management settings - 1 relay

I/O Power Management

V+ /GND

I/O

I

V+	V+	0	2	4	6	8	10
GND	GND	1	3	5	7	9	11

DNO feedback pin
Not used ▼

Rules
+ Add

Rule 1
🗑️ ^

0	2	4	6	8	10
1	3	5	7	9	11

Limitation
I/O Generation Limit (%) ▼

Active Power *

100
%

Power Factor (cos φ) *

1

Impedance response
Capacitive
▼

DNO Feedback

Rule 2
🗑️ ^

0	2	4	6	8	10
1	3	5	7	9	11

Limitation
I/O Generation Limit (%) ▼

Active Power *

0
%

Power Factor (cos φ) *

1

Impedance response
Capacitive
▼

DNO Feedback

📄 Import
📄 Export

- 0 Activate Backup interlock
- 1 Rule 1
- 2 None
- 3 None
- 4 None
- 5 None
- 6 Open grid relais feedback
- 7 Backup interlock feedback
- 8 I/O control
- 9 None
- 10 None
- 11 None

Connecting the ripple control receiver with several inverters

The grid operator may request the connection of one or more inverters to a ripple control receiver in order to limit the effective power and/or the power factor of the photovoltaic system.

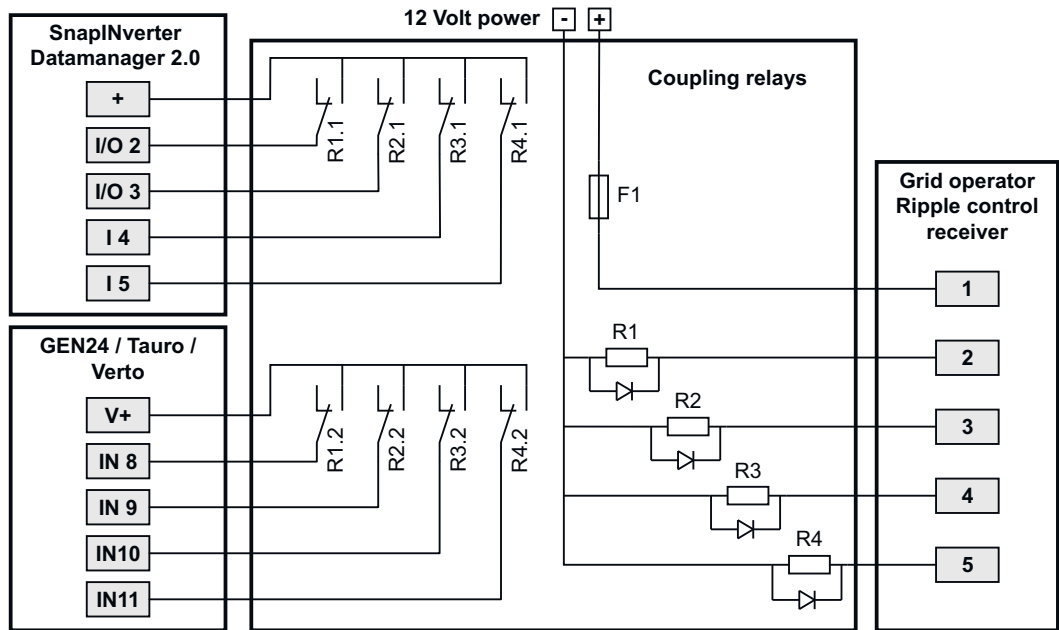

Connection diagram for ripple control receiver with several inverters

The following Fronius inverters can be connected to the ripple control receiver via a distributor (coupling relay):

- Symo GEN24
- Primo GEN24
- Tauro
- Verto
- SnapINverter (only devices with Fronius Datamanager 2.0)

IMPORTANT!

On the user interface of each inverter connected to the ripple control receiver, the **4-relay mode** setting (see [Connection diagram - 4 relays](#) and [I/O power management settings - 4 relays](#)) must be activated.

Autotest (CEI 0-21)

Description

The **Autotest** makes it possible to check the Italian protection function, required by the applicable standard for monitoring the voltage and frequency limit values of the inverter during commissioning. In normal operation, the inverter constantly checks the real-time actual value of the voltage and frequency of the grid.

Once the Autotest has started, different individual tests are carried out automatically, in succession. Depending on the grid conditions, the duration of the test is approximately 15 minutes.

IMPORTANT!

In Italy, the inverter may only be commissioned following a successfully completed Autotest (CEI 0-21). If an Autotest is not passed, grid power feed operation may not take place. Once the Autotest is started, it must be completed successfully. The Autotest cannot be started during backup power mode.

Umax	Test for checking the maximum voltage in the phase conductors
Umin	Test for checking the minimum voltage in the phase conductors
fmax	Test for checking the maximum mains frequency
fmin	Test for checking the minimum mains frequency

fmax alt	Test for checking an alternative maximum mains frequency
fmin alt	Test for checking an alternative minimum mains frequency
U outer min	Test for checking the minimum outer voltages
U longT.	Test for checking the 10 min. voltage average

Print to PDF

- 1 Click the **Print to PDF** button.
- 2 Enter the file name into the input field and click on the **Print** button.

✓ *The PDF is created and shown.*

Note on the Autotest

The limit values are set in the **Safety and Grid Regulations > Country Setup > Grid Support Functions** menu area.

The **Country Setup** menu area is intended exclusively for installers/service technicians from authorized specialist companies. The inverter access code required for this menu area can be requested in the Fronius Solar.SOS portal (see chapter [Requesting inverter codes in Solar.SOS](#) on page 116).

Options

Surge protection device (SPD)

General

A surge protection device (SPD) protects against temporary overvoltages and diverts surge currents (e.g., lightning strike). Based on an overall lightning protection concept, the SPD contributes to the protection of the photovoltaic system components.

For detailed information on the wiring diagram of the surge protection device, see chapter [Surge protection device \(SPD\)](#) on page 196.

If the surge protection device is triggered, the color of the indicator changes from green to red (mechanical display) and the operating status LED of the inverter lights up red (see chapter [Button functions and LED status indicator](#) on page 39). The error code **1030 WSD Open** is displayed on the user interface of the inverter in the **System > Event Log** menu area or in the user menu under **Notifications** and in Fronius Solar.web. In this case, the inverter must be repaired by an authorized specialist company.

IMPORTANT!

The inverter also switches off if the 2-pin signal cable of the surge protection device is interrupted or damaged.

External surge protection device

To receive a notification when external surge protection devices are triggered, it is recommended to connect the feedback contacts connected in series to the WSD input.

Safety



WARNING!

Danger due to electrical voltage on live parts of the photovoltaic system.

This can result in serious injury and damage to property.

- ▶ Disconnect live parts of the photovoltaic system on all pins and on all sides.
- ▶ Secure against re-activation in accordance with national regulations.
- ▶ Allow the capacitors of the inverter to discharge (2 minutes).
- ▶ Check that the inverter is de-energized with a suitable measuring device.



WARNING!

Danger due to work that has been carried out incorrectly.

This can result in serious injury and damage to property.

- ▶ Installing and connecting an option must only be carried out by service personnel trained by Fronius and only within the scope of the respective technical regulations.
- ▶ Follow the safety rules.

Scope of supply

The surge protection device (SPD) is available as an option and can be retrofitted to the inverter.

For technical data, see chapter [Technical data](#) on page 172.

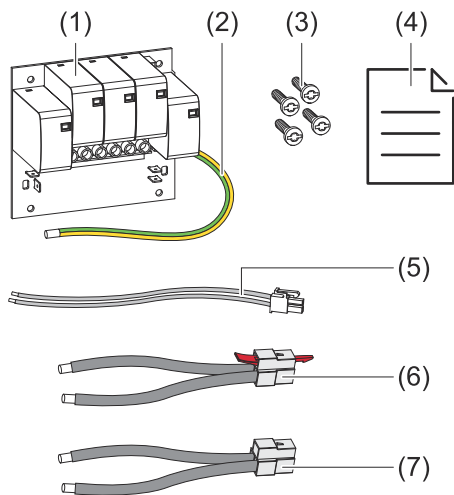

1. PC board
2. 4 TX20 screws
3. Ground conductor
4. 2-pin signal cable
5. PV- cable
6. PV+ cable
7. User information

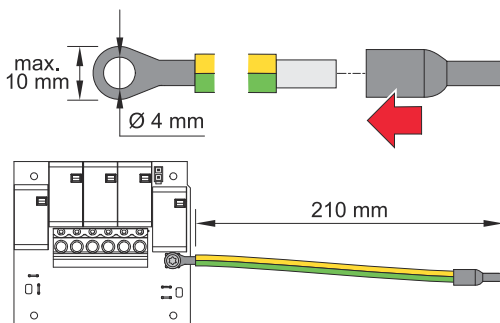

IMPORTANT!

A larger ground conductor cross-section may be required depending on national standards and regulations.

Fit a ring cable lug (internal diameter: 4 mm, outer diameter: max. 10 mm) as well as a corresponding ferrule. Fasten the ground conductor to the PC board with a torque of 1.5 Nm.

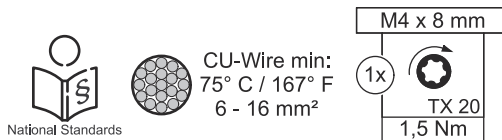

De-energizing the inverter

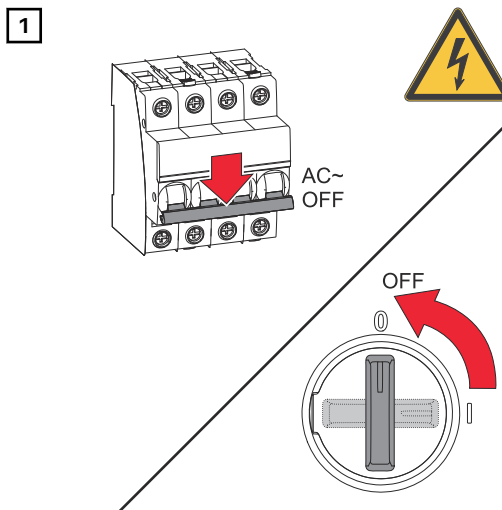

Turn off the automatic circuit breaker. Set the DC disconnect to the "off" switch position.

2 Disconnect connections from the solar module strings (+/-).

3

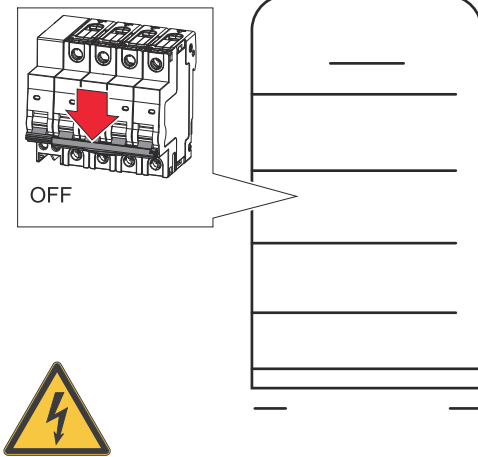

Switch off the battery connected to the inverter.

Wait for the capacitors of the inverter to discharge (2 minutes).

Installation

CAUTION!

Danger due to insufficiently dimensioned ground conductors.

This may result in damage to the inverter due to thermal overload.

- The national standards and regulations must be observed for dimensioning of the ground conductor.

1

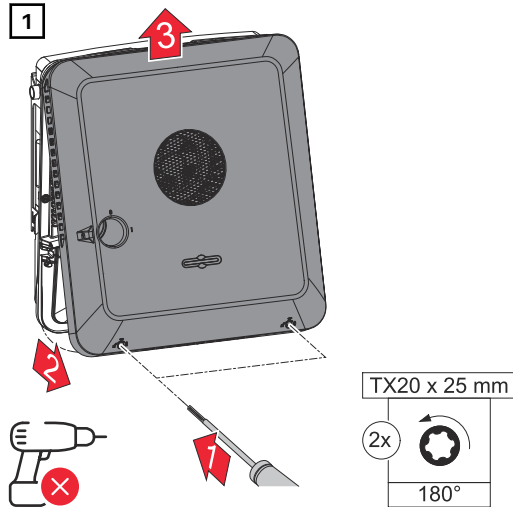

Loosen the 2 screws on the underside of the housing cover by rotating them 180° to the left using a screwdriver (TX20). Then lift the housing cover away from the inverter at the bottom and detach from above.

2

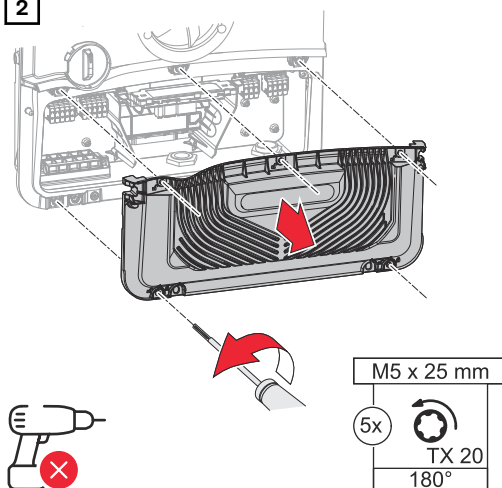

Loosen the 5 screws on the connection area cover by rotating them 180° to the left using a screwdriver (TX20). Remove the connection area cover from the device.

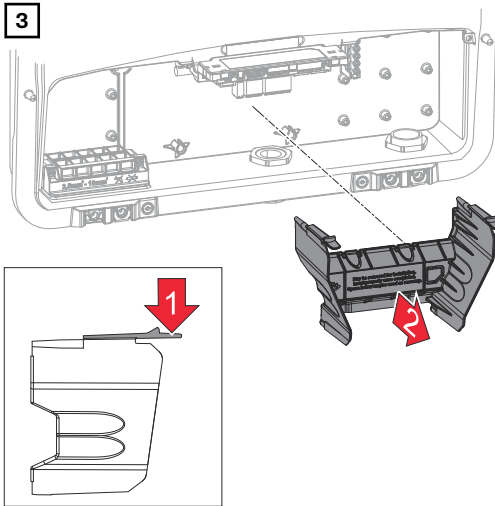

Remove the connection area divider by pressing the snap tabs.

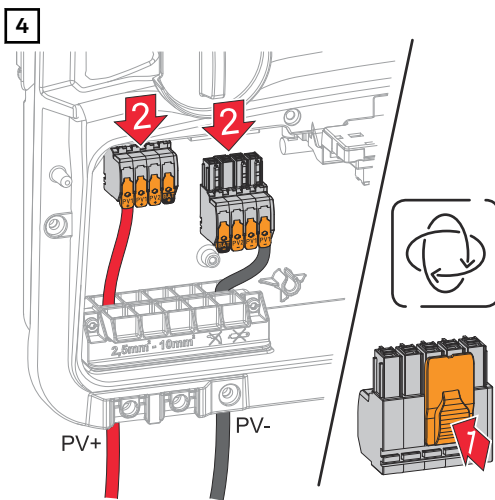

Remove the DC push-in terminals from the slots and disconnect them from the cables (only necessary for an existing installation).

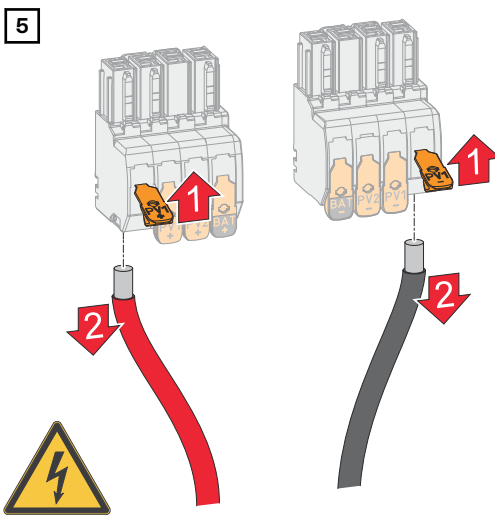

Remove cables from the terminals (only necessary for an existing installation).

6

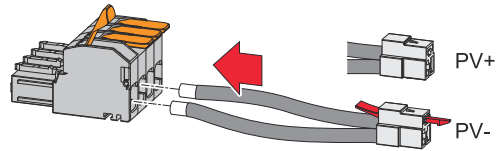

Connect the PV+/PV- cables supplied to the corresponding connection sockets.

IMPORTANT!

When connecting, note the labeling on the cables.

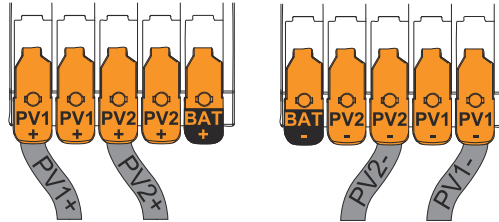

7

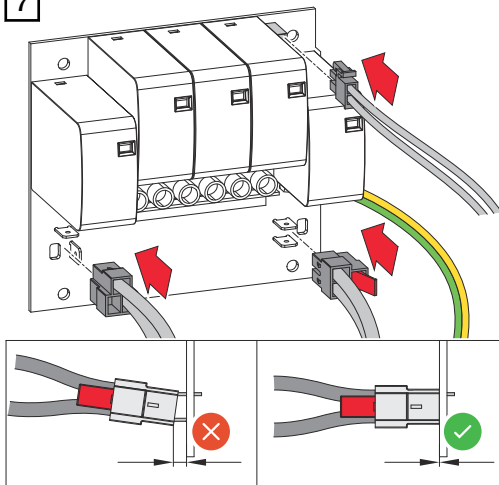

Connect the cables supplied to the corresponding connection sockets on the PC board.

IMPORTANT!

The plugs must be plugged in to the stops on the PC board.

8

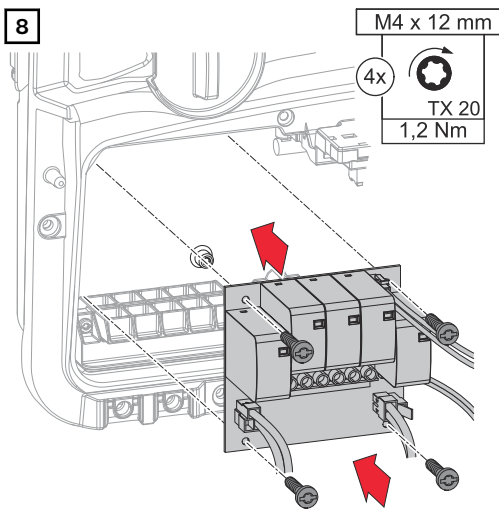

Insert the PC board into the inverter and fasten it using the 4 screws supplied (TX20) and a torque of 1.2 Nm.

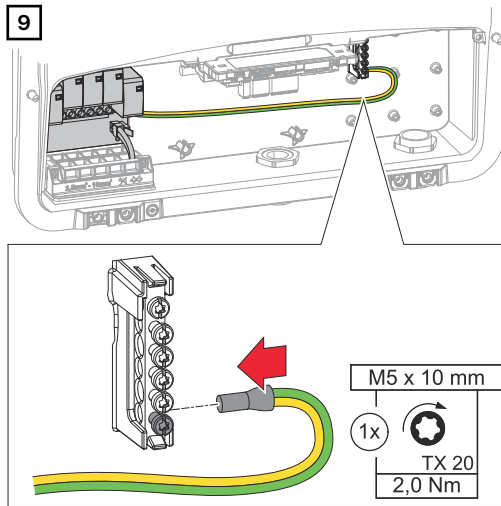

Fasten the ground conductor to the first input from the bottom on the ground electrode terminal using a screwdriver (TX20) and a torque of 2 Nm.

IMPORTANT!

Using other inputs can make the use of the connection area dividers more difficult or damage the ground conductor.

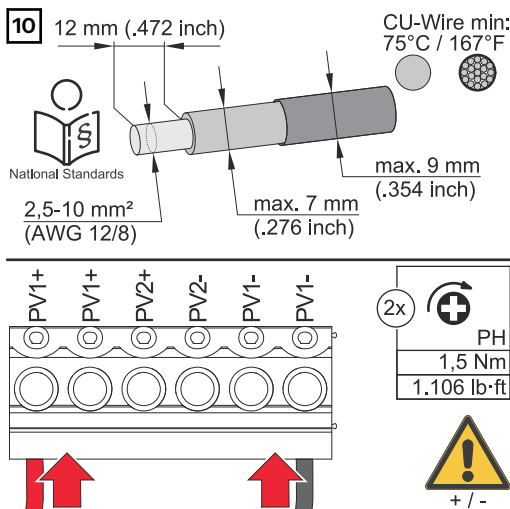

Strip 12 mm of insulation from the single conductors. Fasten to the respective slot of the terminal located on the PC board with a torque of 1.5 Nm.

IMPORTANT!

The cable cross-section must be selected according to the specifications for the respective power category of the inverter (see chapter [Permissible cables for the electrical connection](#) on page 57).

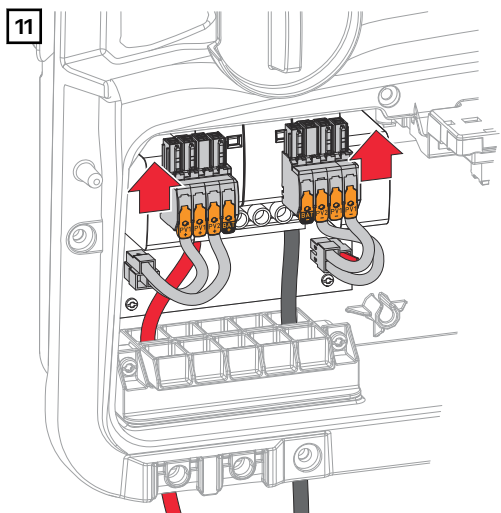

Push the DC push-in terminals into the corresponding slot until there is an audible click.

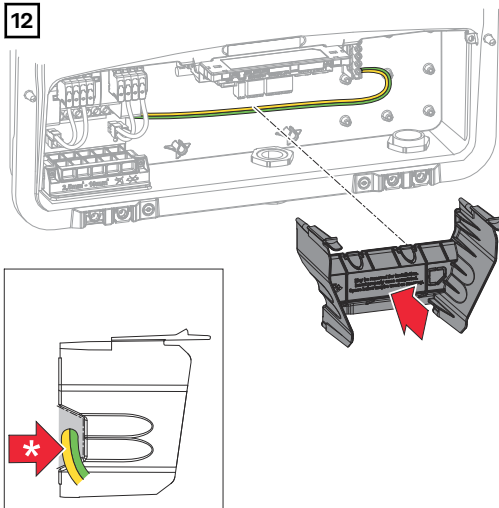

Re-insert the connection area divider.

* Lay the ground conductor in the integrated cable duct.

IMPORTANT!

Ensure that the ground conductors are not damaged (e.g., broken, kinked, crushed, etc.) when inserting the connection area divider.

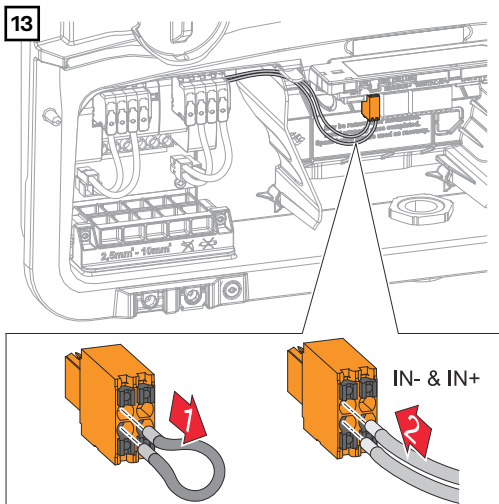

Remove the bypass installed ex works on the push-in WSD terminal. Connect the signal cables to the IN- and IN+ slots in accordance with the labeling on the push-in WSD terminal.

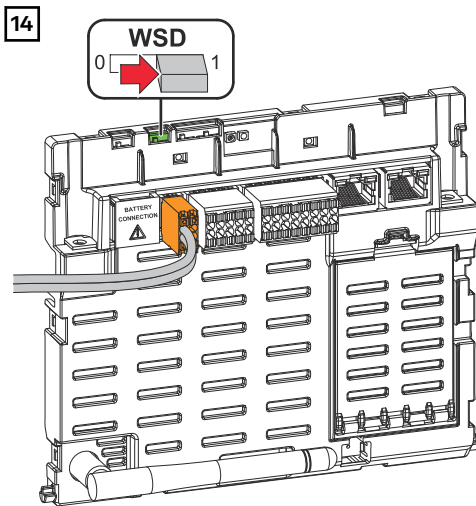

Check whether the WSD switch is in position 1 (factory setting).

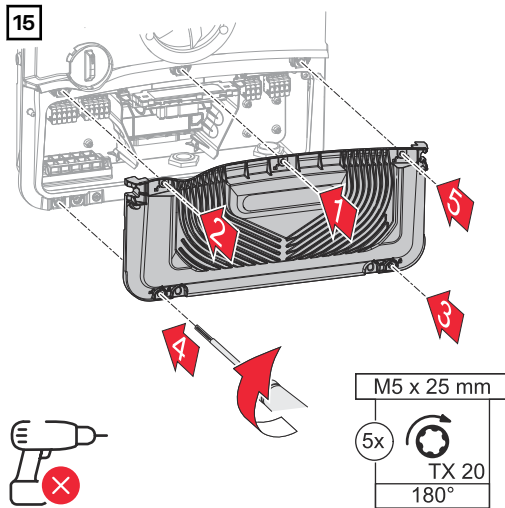

Place the cover on the connection area. Tighten the 5 screws by rotating them 180° to the right in the indicated order using a screwdriver (TX20).

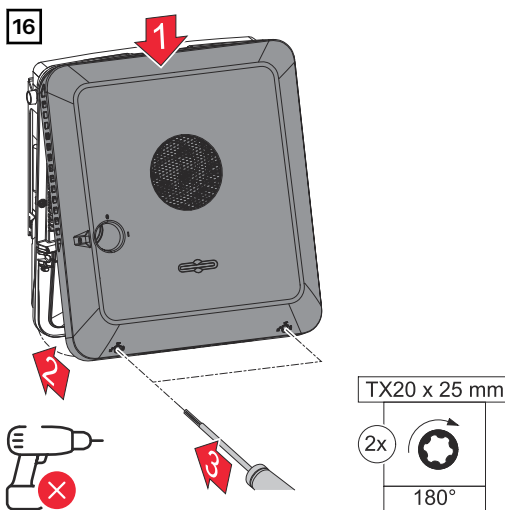

Clip the housing cover into the inverter from above. Press on the lower part of the housing cover and tighten the 2 screws by rotating them 180° to the right using a screwdriver (TX20).

Starting up the inverter

1 Connect the solar module strings (+/-).

2

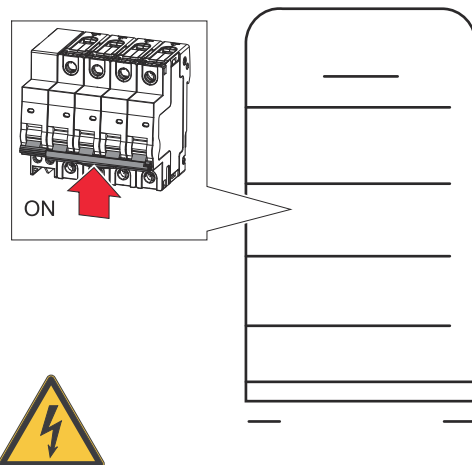

Switch on the battery connected to the inverter.

3

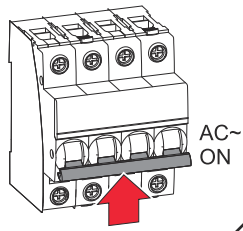

Set the DC disconnecter to the "on" switch position. Turn on the automatic circuit breaker.

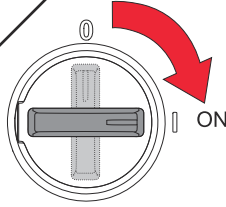

DC Connector Kit GEN24

General

The DC Connector Kit GEN24 (item number: 4,240,046) enables PV-connection strings with a total current of more than 28 A to be connected.

IMPORTANT!

If the Arc Fault Circuit Interrupter (AFCI) integrated in the inverter is used for the arc detection requirement according to IEC 63027, the DC Connector Kit GEN24 must **not be used**. Installation must be carried out in accordance with the nationally applicable standards and guidelines.

General information about PV modules

To enable suitable PV modules to be chosen and to use the inverter as efficiently as possible, it is important to bear the following points in mind:

- If insolation is constant and the temperature is falling, the open circuit voltage of the PV modules will increase. The open circuit voltage must not exceed the max. permissible system voltage. An open circuit voltage above the indicated values will damage the inverter, and all warranty rights will become null and void.
- The temperature coefficients on the data sheet of the PV modules must be observed.
- Exact values for sizing the PV modules can be obtained using suitable calculation tools, such as the [Fronius Solar.creator](#).

IMPORTANT!

Before connecting up the PV modules, check that the voltage for the PV modules specified by the manufacturer corresponds to the actual measured voltage.

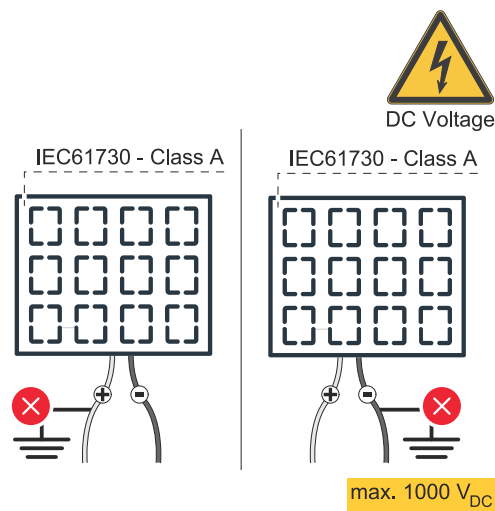

IMPORTANT!

The PV modules connected to the inverter must comply with the IEC 61730 Class A standard.

IMPORTANT!

Solar module strings must not be grounded.

Safety



WARNING!

Danger from incorrect operation and work that is not carried out properly.

This can result in severe personal injury and damage to property.

- ▶ The commissioning, maintenance, and service work in the inverter's power stage set may only be carried out by Fronius-trained service personnel in accordance with the technical specifications.
- ▶ Read the installation instructions and operating instructions before installing and commissioning the equipment.

⚠ WARNING!

Danger from mains voltage and DC voltage from PV modules that are exposed to light.

This can result in severe personal injury and damage to property.

- ▶ All connection, maintenance, and service work should only be carried out when the AC and DC sides have been disconnected from the inverter and are de-energized.
- ▶ Only an authorized electrical engineer is permitted to connect this equipment to the public grid.

⚠ WARNING!

Danger of an electric shock due to improperly connected terminals/PV plug connectors.

An electric shock can be fatal.

- ▶ When connecting, ensure that each pole of a string is routed via the same PV input, e.g.:
+ pole string 1 to the input **PV 1.1+** and **- pole string 1** to the input **PV 1.1-**

⚠ WARNING!

Danger from damaged and/or contaminated terminals.

This can result in severe personal injury and damage to property.

- ▶ Prior to connection work, check the terminals for damage and contamination.
- ▶ Remove any contamination while the equipment is de-energized.
- ▶ Have defective terminals replaced by an authorized specialist company.

Scope of supply

The DC Connector Kit GEN24 is available as an option and can be retrofitted to the inverter.

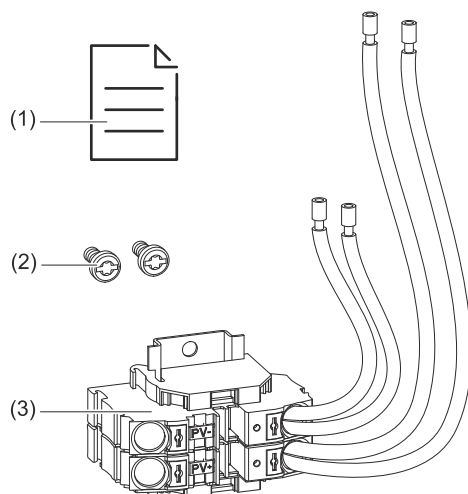

1. User information
2. 2 TX20 screws
3. DC Connector Kit GEN24

De-energizing the inverter

1

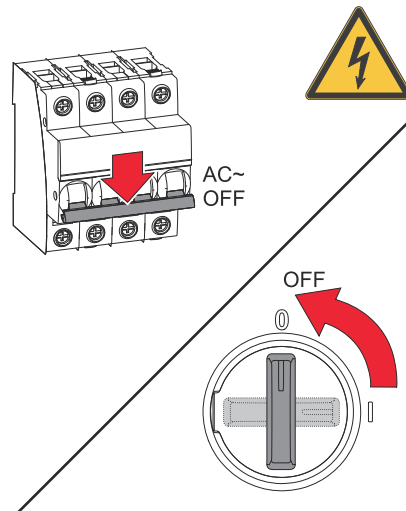

Turn off the automatic circuit breaker. Set the DC disconnect to the "off" switch position.

2

Disconnect connections from the solar module strings (+/-).

3

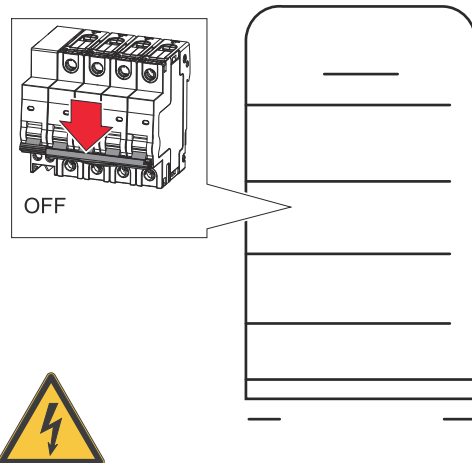

Switch off the battery connected to the inverter.

Wait for the capacitors of the inverter to discharge (2 minutes).

Installation

CAUTION!

Risk due to insufficiently dimensioned DC cables.

This may result in damage to the inverter due to thermal overload.

- ▶ For dimensioning the DC cables, observe the information according to chapter [Permissible cables for the electrical connection](#) on page 57.

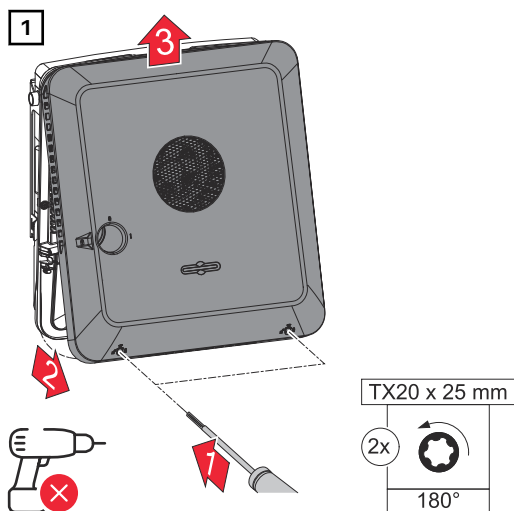

Loosen the 2 screws on the underside of the housing cover by rotating them 180° to the left using a screwdriver (TX20). Then lift the housing cover away from the inverter at the bottom and detach from above.

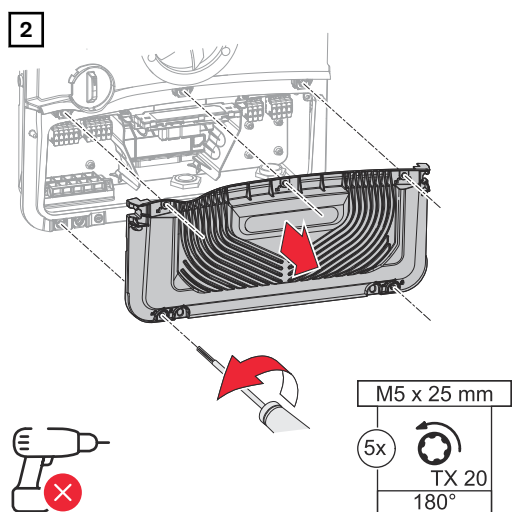

Loosen the 5 screws on the connection area cover by rotating them 180° to the left using a screwdriver (TX20). Remove the connection area cover from the device.

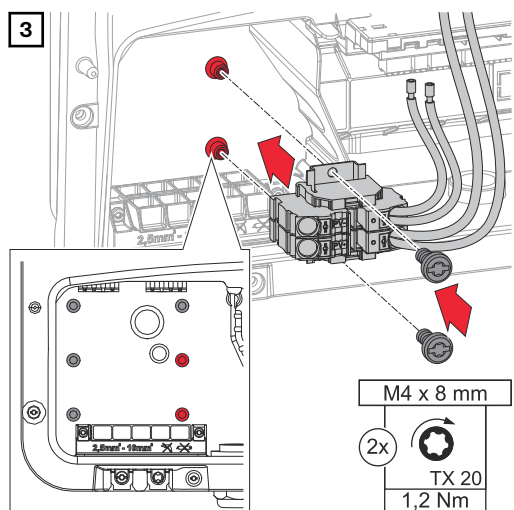

Insert the DC Connector GEN24 into the inverter and fasten it using the 2 screws supplied (TX20) and a torque of 1.2 Nm.

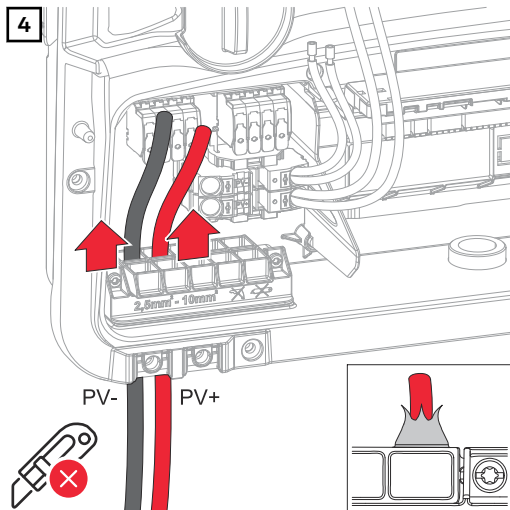

Push the DC cables through the DC bushings by hand.

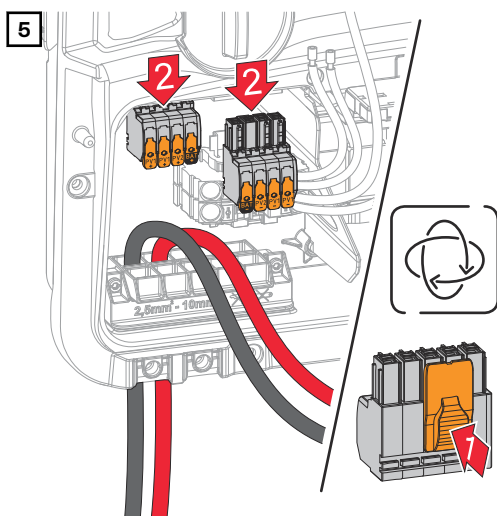

Press the latch on the back of the terminal and remove the DC terminals.

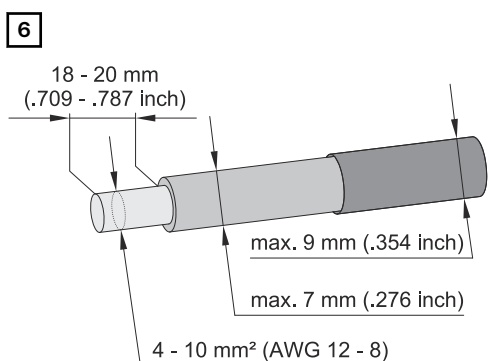

Strip the insulation of the single conductors by 18 - 20 mm. Select the cable cross-section in accordance with the instructions in [Permissible cables for the electrical connection](#) from page 57.

CU-Wire min:
75° C / 167° F



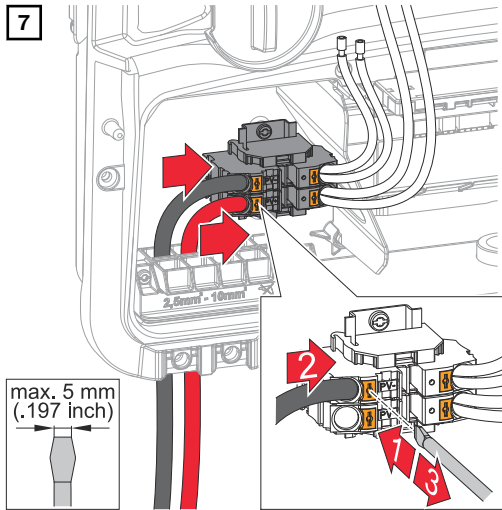

Press the latch on the terminal with a slotted screwdriver. Insert the stripped single conductor into the slot provided in the terminal as far as it will go. Then remove the slotted screwdriver from the latch.

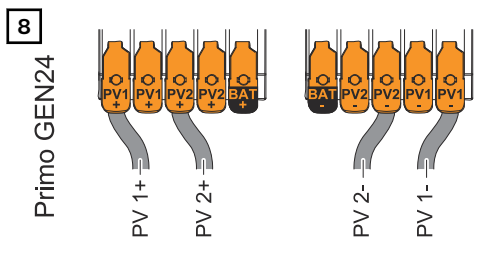

Lift the operating lever of the terminal to open. Insert the stripped single conductor into the slot provided in the terminal as far as it will go. Then close the operating lever until it engages.

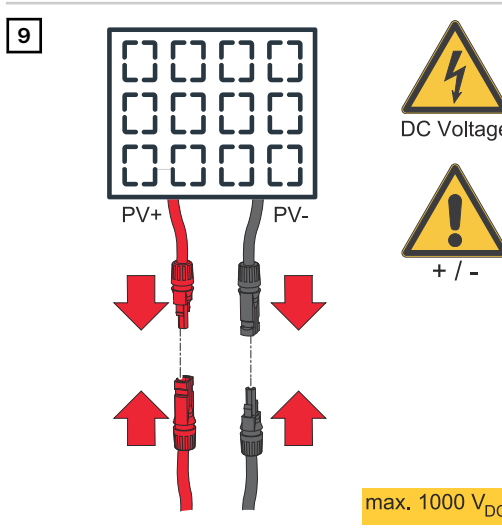
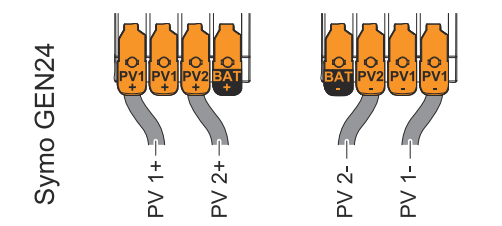

Connect the solar module strings (+/-).

NOTE!
Danger due to polarity reversal at the terminals.
 This may result in severe damage to the inverter.
 ► Use a suitable measuring instrument to check the voltage (**max. 1000 V_{DC}**) and the polarity of the DC cabling.

10

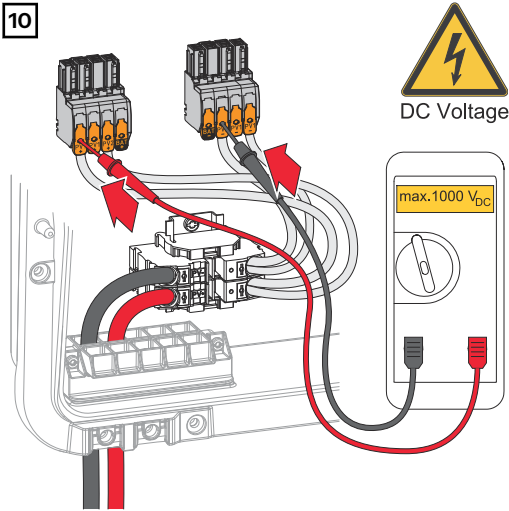

Use a suitable measuring instrument to check the voltage and polarity of the DC cabling.

NOTE!

Risk due to overtorque at the strain-relief device.

Damage to the strain-relief device may result.

► Do not use a drill driver.

11

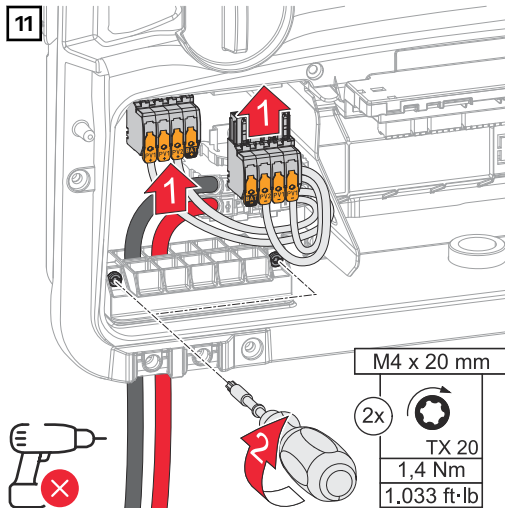

Insert the DC terminals into the respective slot until they engage. Fasten the screws of the strain-relief device to the housing using a screwdriver (TX20) and a torque of 1.4 Nm.

12

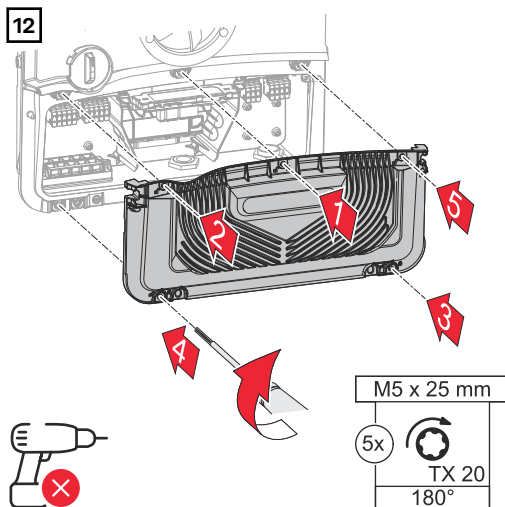

Place the cover on the connection area. Tighten the 5 screws by rotating them 180° to the right in the indicated order using a screwdriver (TX20).

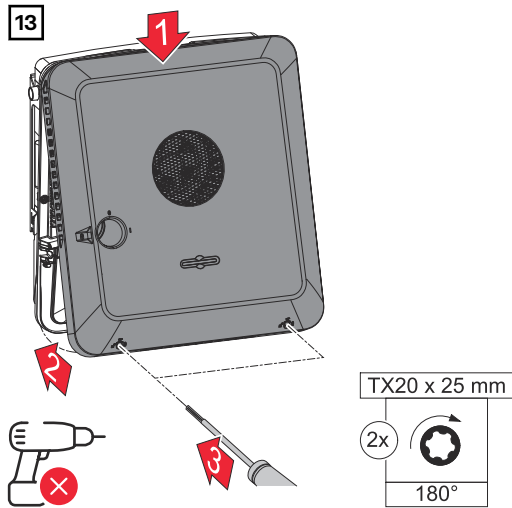

Clip the housing cover into the inverter from above.
Press on the lower part of the housing cover and tighten the 2 screws by rotating them 180° to the right using a screwdriver (TX20).

Starting up the inverter

1 Connect the solar module strings (+/-).

2

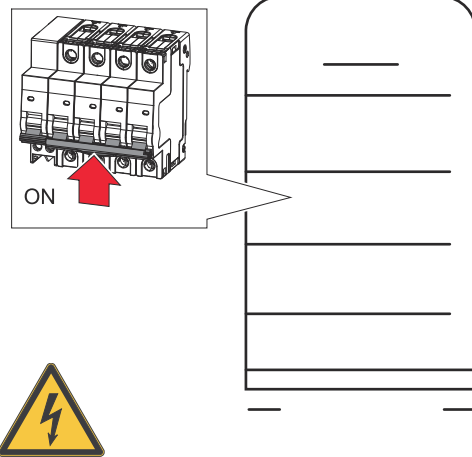

Switch on the battery connected to the inverter.

3

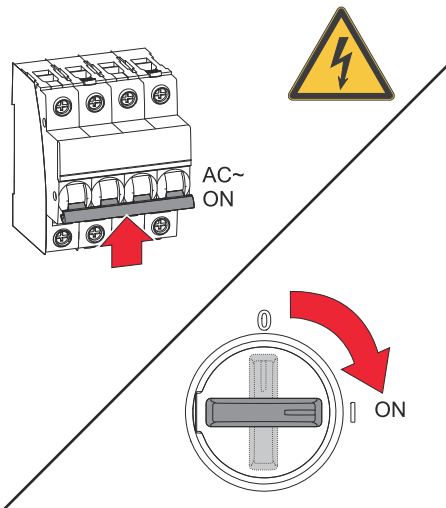

Set the DC disconnect to the "on" switch position. Turn on the automatic circuit breaker.

PV Point Comfort

Safety

WARNING!

Danger due to electrical voltage on live parts of the photovoltaic system.

This can result in serious injury and damage to property.

- ▶ Disconnect live parts of the photovoltaic system on all pins and on all sides.
- ▶ Secure against re-activation in accordance with national regulations.
- ▶ Allow the capacitors of the inverter to discharge (2 minutes).
- ▶ Check that the inverter is de-energized with a suitable measuring device.

WARNING!

Danger due to work that has been carried out incorrectly.

This can result in serious injury and damage to property.

- ▶ Installing and connecting an option must only be carried out by service personnel trained by Fronius and only within the scope of the respective technical regulations.
- ▶ Follow the safety rules.

WARNING!

Danger due to damaged and/or contaminated terminals.

This can result in serious injury and damage to property.

- ▶ Before making any connections, check the terminals for damage and contamination.
- ▶ Remove contamination in the de-energized state.
- ▶ Have defective terminals repaired by an authorized specialist.

CAUTION!

Danger due to electrostatic discharge (ESD).

This may result in damage to electronic components.

- ▶ Pay attention to the ESD marking on the product and/or on the packaging.
- ▶ Take ESD protection measures (grounding, neutralizing, and shielding).

NOTE!

The continuous supply via the PV Point depends on the available PV power.

If the solar modules are not supplying enough power, interruptions may occur.

- ▶ Do not connect any loads that require an uninterruptible supply.

IMPORTANT!

The valid national laws, standards, and provisions, as well as the specifications of the relevant grid operator are to be taken into account and applied.

It is highly recommended that the specific installation be agreed with the grid operator and explicitly approved by this operator. This obligation applies to system constructors in particular (e.g., installers).

Scope of supply

The PV Point Comfort is available as an option and can be retrofitted to the inverter.

For technical data, see chapter [Technical data](#) on page 172.

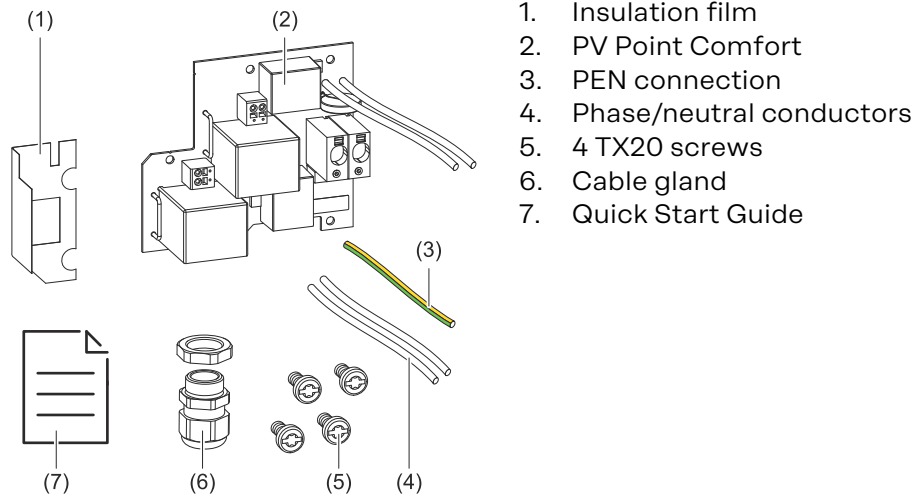

De-energizing the inverter

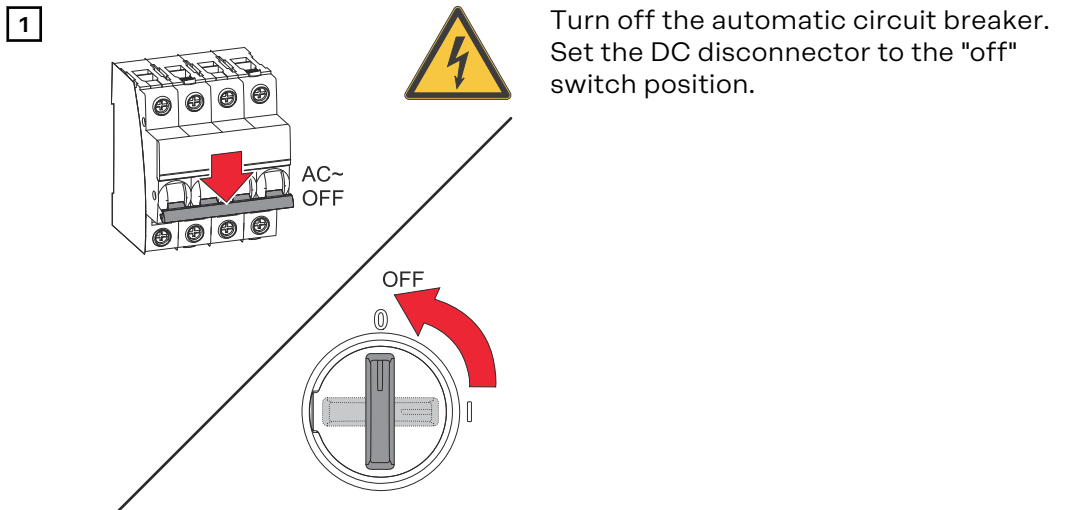

2 Disconnect connections from the solar module strings (+/-).

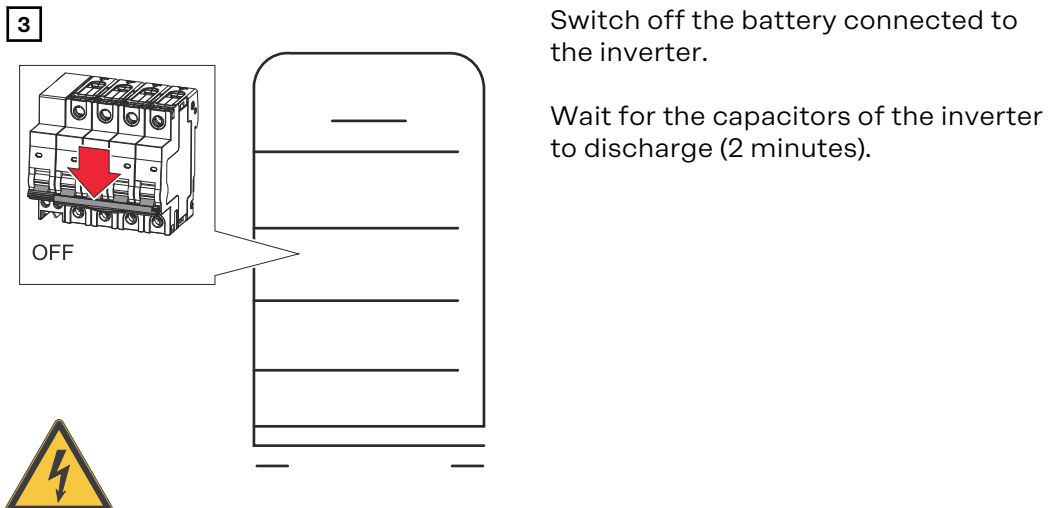

NOTE!

Danger due to insufficiently dimensioned ground conductors.

This may result in damage to the inverter due to thermal overload.

- ▶ Observe the national standards and regulations for dimensioning of the ground conductor.

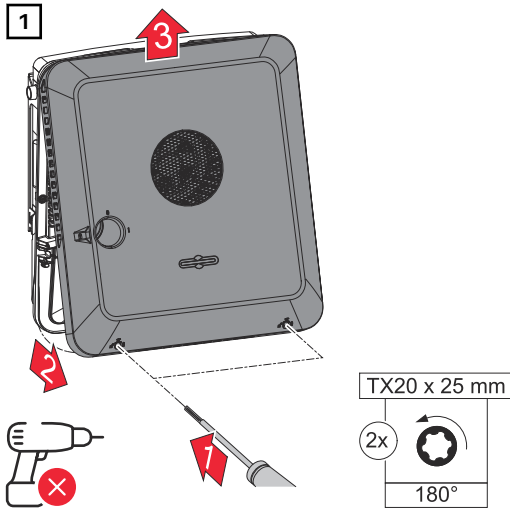

Loosen the 2 screws on the underside of the housing cover by rotating them 180° to the left using a screwdriver (TX20). Then lift the housing cover away from the inverter at the bottom and detach from above.

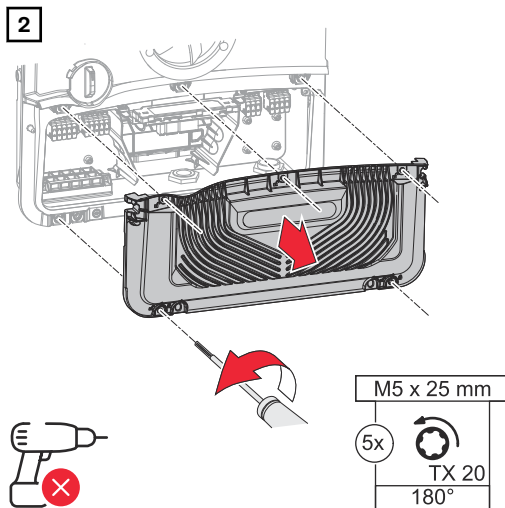

Loosen the 5 screws on the connection area cover by rotating them 180° to the left using a screwdriver (TX20). Remove the connection area cover from the device.

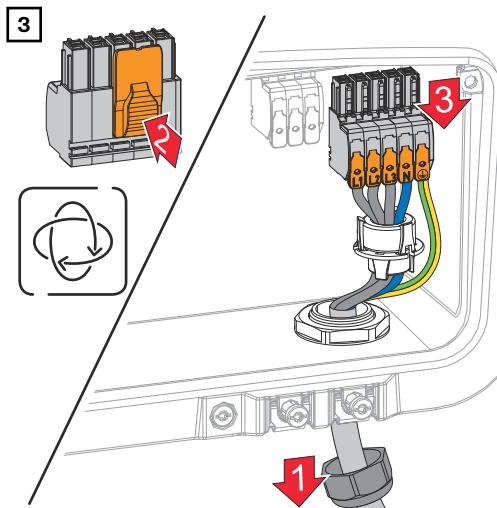

Press the latch on the back of the terminal and remove the AC terminals. Loosen the cable gland.

4

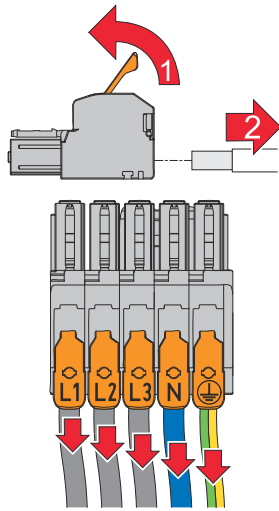

Disconnect the single conductors from the AC terminal (only necessary for an existing installation).

5

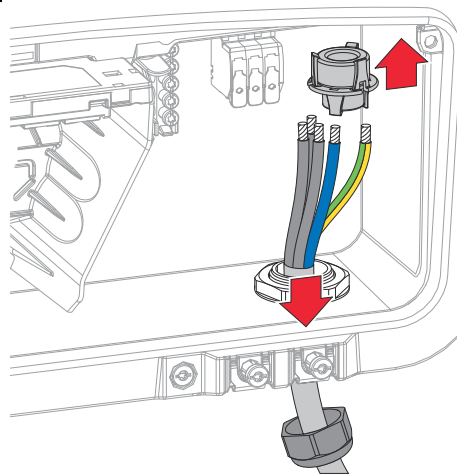

Remove the ferrite core and the mains cable from the inverter.

6

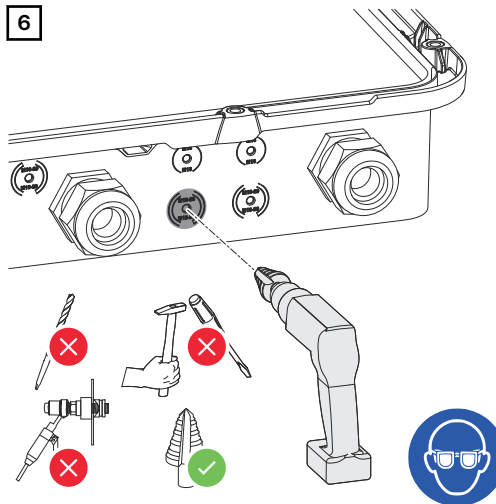

Drill out the optional cable gland with a step drill.

7

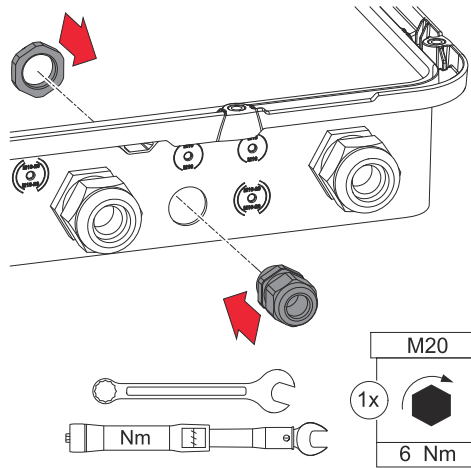

Insert the cable gland into the hole and fasten with a torque of 6 Nm.

8

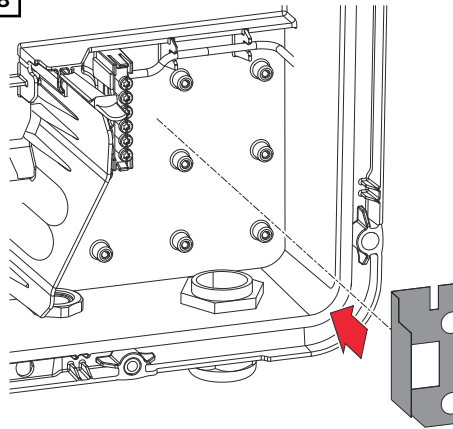

Insert the insulating film on the right side of the ground electrode terminal.

9

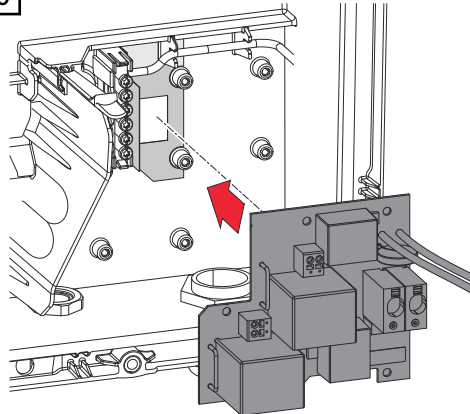

Insert the PC board into the inverter.

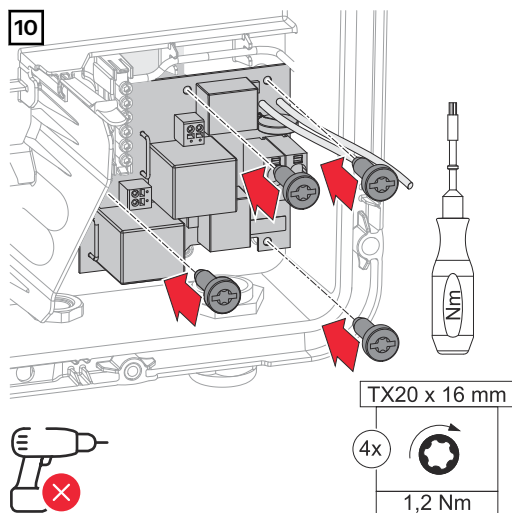

Fasten the PC board using the 4 screws supplied (TX20) and a torque of 1.2 Nm.

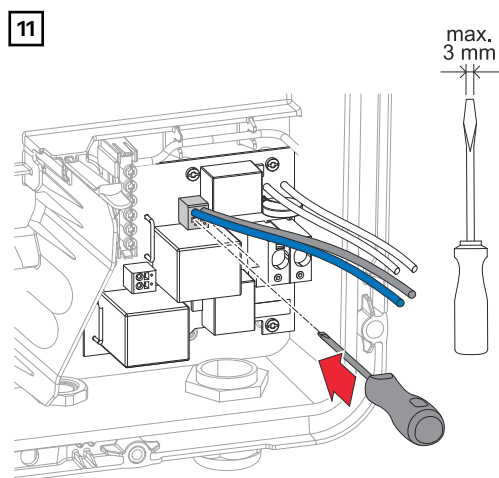

Fasten the supplied phase and neutral conductors to the terminal using a slotted screwdriver.

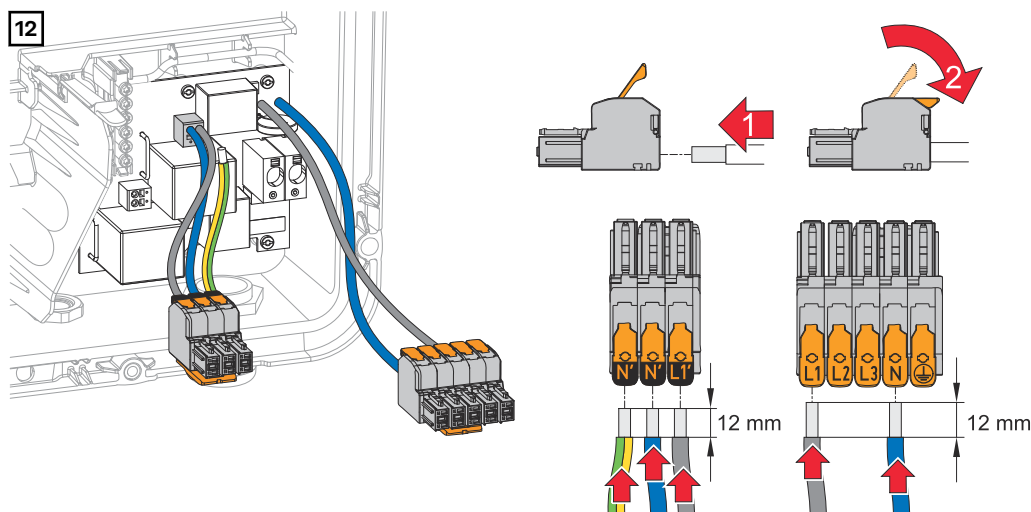

Strip 12 mm of insulation from the single conductors. Lift the operating lever of the AC terminal to open. Insert the stripped single conductor into the slot provided in the AC terminal as far as it will go. Then close the operating lever until it engages.

IMPORTANT!

Establish the PEN connection in accordance with national regulations. If necessary, replace the supplied PEN connection.

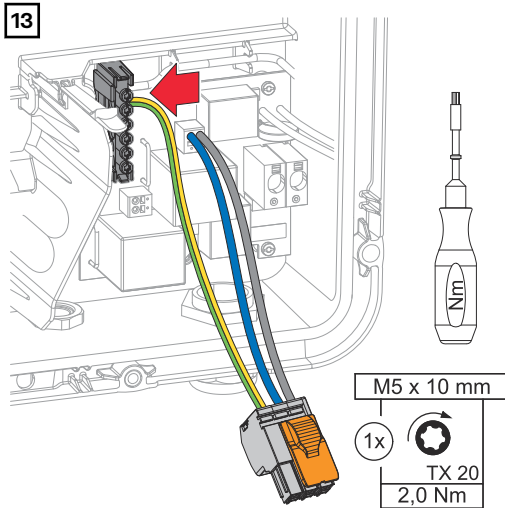

Fasten the PEN connection to the ground electrode terminal at the second input from above using a screwdriver (TX20) and a torque of 1.8 - 2 Nm.

14

Inverter (AC~)		\varnothing	
Symo GEN24 3 - 10 kW	Cu	2,5 - 10 mm ²	12 mm
PV Point		\varnothing	
	Cu	1,5 - 2,5 mm ²	12 mm

Strip 12 mm of the insulation from the single conductors. Select the cable cross-section according to the specifications for the respective power category of the inverter (see chapter [Permissible cables for the electrical connection](#) on page 57). Execute the residual current circuit breaker and automatic circuit breaker in accordance with national regulations.

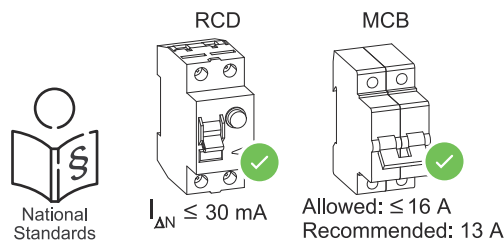

IMPORTANT!

If necessary, use an automatic circuit breaker with a maximum 16 A for fuse protection. A max of 13 A can be supplied in backup power mode. If the inverter is protected with an automatic circuit breaker with a maximum 16 A, it is possible to dispense with an additional automatic circuit breaker.

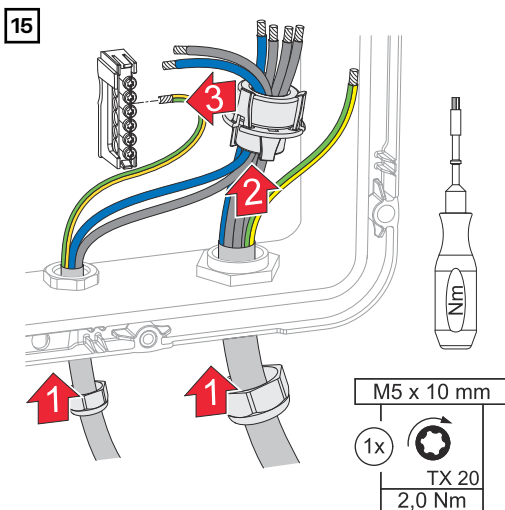

Pass the phase/neutral conductors through the ferrite core. Fasten the ground conductor to the ground electrode terminal at the third input from above using a screwdriver (TX20) and a torque of 1.8 - 2 Nm.

IMPORTANT!

The ground conductors must not be passed through the ferrite core and must be connected using a movement loop so that the ground conductors are disconnected last if the cable glands fail.

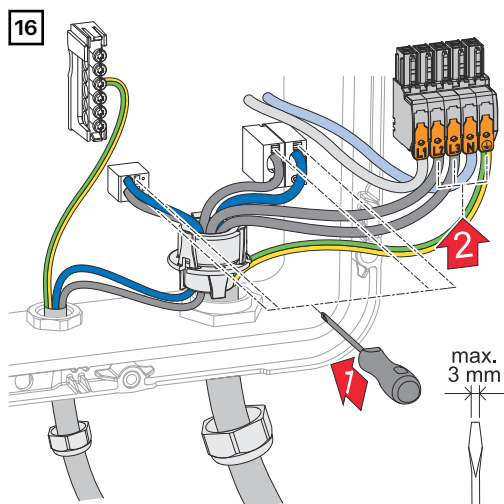

Connect the stripped phase/neutral conductors to the terminals provided.

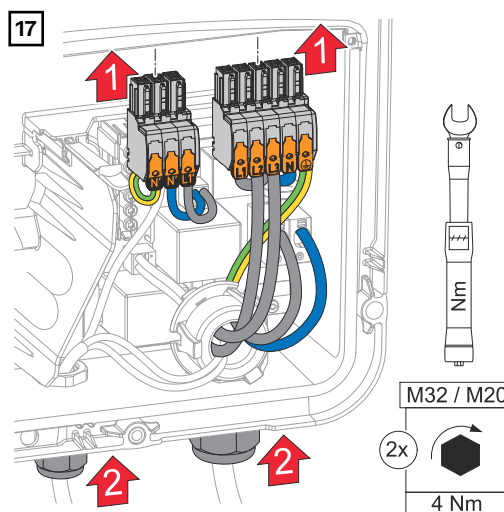

Insert the terminals into the respective slot until they engage. Fasten the union nuts of the cable glands with a torque of 4 Nm.

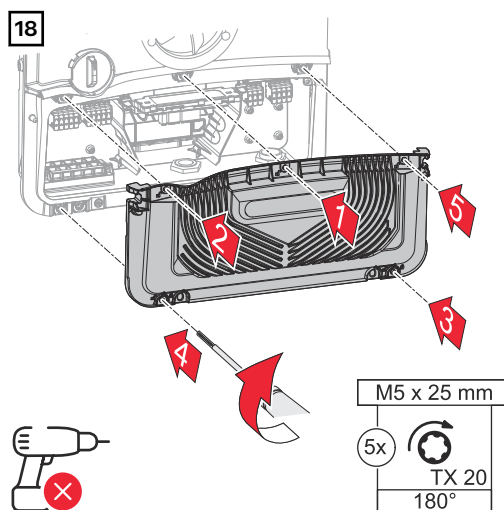

Place the cover on the connection area. Tighten the 5 screws by rotating them 180° to the right in the indicated order using a screwdriver (TX20).

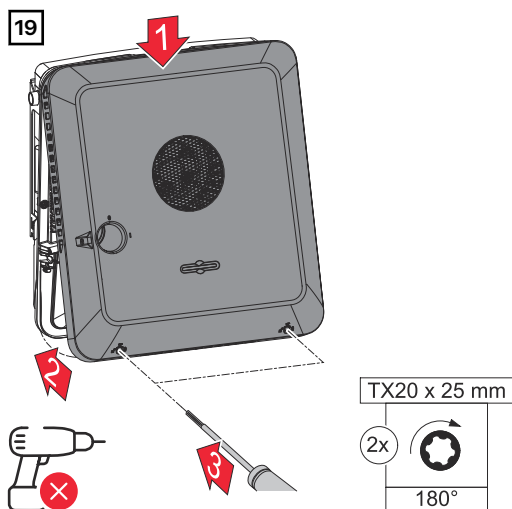

Clip the housing cover into the inverter from above.
Press on the lower part of the housing cover and tighten the 2 screws by rotating them 180° to the right using a screwdriver (TX20).

Starting up the inverter

1 Connect the solar module strings (+/-).

2

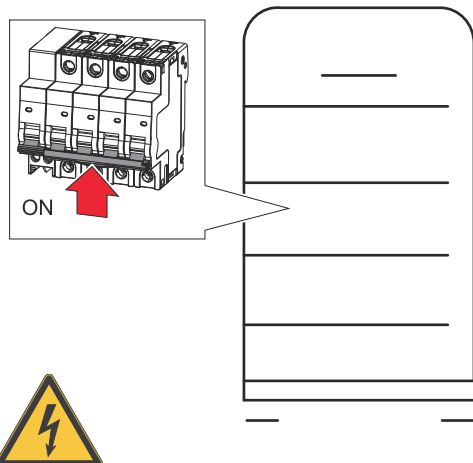

Switch on the battery connected to the inverter.

3

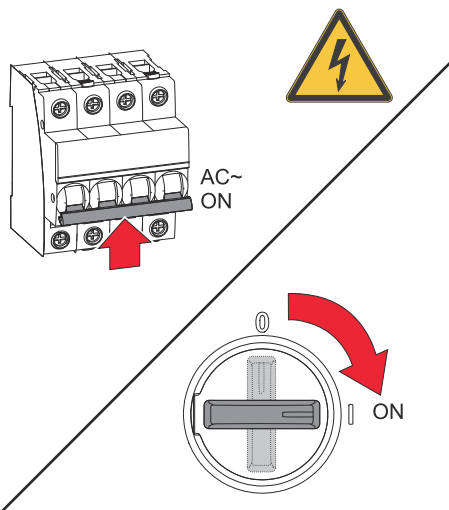

Set the DC disconnecter to the "on" switch position. Turn on the automatic circuit breaker.

Configuring the PV Point Comfort

Firmware version 1.25.2 or higher is required to commission the PV Point Comfort. Outdated firmware versions could lead to incompatibilities between the inverter and PV Point Comfort. In this case, the inverter firmware should be updated in accordance with the chapter headed [Update](#) on page 108.

- 1 Call up the user interface of the inverter.
 - Open web browser.
 - In the browser's address bar, enter the IP address (IP address for WLAN: 192.168.250.181, IP address for LAN: 169.254.0.180) or enter and confirm the host and domain name of the inverter.
 - ✓ *The user interface of the inverter is displayed.*
 - 2 Click on the **Device Configuration** button.
 - 3 Log in to the login area with user **Technician** and the technician password.
 - 4 Go to the **Device Configuration > Functions and I/Os** menu area.
 - 5 Enable the **Backup Power** function.
 - 6 Select **PV Point** mode in the **Backup Power Mode** drop-down list.
 - 7 Click the **Save** button to save the settings.
 - ✓ *The **PV Point** backup power mode has been configured.*
-

Testing backup power mode

Testing backup power mode:

- during first-time installation and configuration
- after working on the switch cabinet
- during ongoing operation (recommendation: at least every 6 months)

A battery charge of min. 30% is recommended for test mode.

A description of how to run the test mode can be found in the [checklist – Backup power](https://www.fronius.com/de/download-center?search-word=42,0426,0365) (https://www.fronius.com/de/download-center?search-word=42,0426,0365).

Appendix

Service, maintenance and disposal

General The inverter is designed so that it does not require additional maintenance work. Nevertheless, a few points must be considered during operation to ensure that the inverter works perfectly.

Maintenance Maintenance and service work may only be carried out by a technical specialist.

Cleaning Wipe the inverter, if necessary, with a damp cloth.
Do not use cleaning agents, scouring agents, solvents, or similar products to clean the inverter.

Safety The DC disconnect is used only to switch off power to the power stage set. When the DC disconnect is turned off, the connection area is still energized.

 **WARNING!**

Danger from mains voltage and DC voltage from PV modules.

This can result in severe personal injury and damage to property.

- ▶ The connection area must only be opened by an authorized electrician.
- ▶ The separate power stage set area must only be opened by Fronius-trained service technicians.
- ▶ Prior to any connection work, ensure that the inverter is de-energized on the AC side and the DC side.

 **WARNING!**

Danger of residual voltage from capacitors.

This can result in severe personal injury and damage to property.

- ▶ Allow the capacitors of the inverter to discharge (2 minutes).

Operation in dusty environments

NOTE!

If the inverter is operated in dusty environments, dirt may build up on the heat sink and fan.

This may result in a loss of power due to insufficient cooling of the inverter.

- ▶ Make sure that the ambient air can always flow through the inverter's ventilation slots unimpeded.
- ▶ Remove any build-ups of dirt from the heat sink and the fan.

Disposal

Waste electrical and electronic equipment must be collected separately and recycled in an environmentally sound manner in accordance with the European Directive and national law. Used equipment must be returned to the distributor or through a local authorized collection and disposal system. Proper disposal of the used device promotes sustainable recycling of resources and prevents negative effects on health and the environment.

Packaging materials

- Collect separately
- Observe local regulations
- Crush cardboard boxes

Warranty provisions

Fronius manufacturer's warranty

Detailed warranty conditions specific to your country can be found at www.fronius.com/solar/garantie.

To secure the full warranty period for the newly installed Fronius product, it is necessary to register at www.solarweb.com.

Status codes and remedy

Display

Status codes are displayed on the user interface of the inverter in the **System > Event Log** menu area or in the user menu under **Notifications** and in Fronius Solar.web*.

* If configured accordingly, see chapter [Fronius Solar.web](#) on page 23.

Status codes

1030 – WSD Open (operating LED: flashes red)

Cause: A device that is connected in the WSD chain has interrupted the signal line (e.g., surge protection device) or the bypass installed ex works as standard has been removed and no trigger device has been installed.

Remedy: If the SPD surge protection device has tripped, the inverter must be repaired by an authorized specialist.

OR: Install the bypass installed ex works as standard or a trigger device.

OR: Turn the WSD (wired shutdown) switch to position 1 (WSD primary device).



WARNING!

Danger from work that is not carried out properly.

This can result in serious injury and damage to property.

- ▶ The installation and connection of an SPD surge protection device may only be carried out by Fronius-trained service personnel in accordance with the technical specifications.
 - ▶ Observe safety rules.
-

Technical data

Fronius Symo GEN24 3.0 SC / 3.0 Plus SC

DC input data	
MPP voltage range (at rated power)	115 - 800 V
Maximum connected load ($P_{PV \max}$)	
Total	4500 W _p
PV 1	4500 W _p
PV 2	4500 W _p
Maximum processable PV power	
Total	3150 W _p
PV 1	3150 W _p
PV 2	3150 W _p
Maximum input voltage (at 1000 W/m ² /-10 °C in an open circuit)	1000 V
Minimum input voltage	80 V
Feed-in start voltage in grid operation 5)	80 V
Maximum input current	
PV 1	14 A
PV 2	14 A
Maximum short circuit current for module array ($I_{SC \text{ PV}}$)	
PV 1	20 A
PV 2	20 A
Maximum total short circuit current for module array ($I_{SC \text{ PV1}} + I_{SC \text{ PV2}} = I_{SC \text{ max}}$)	40 A
Max. inverter backfeed current to the array 3)	
PV 1	20 A
PV 2	20 A
Number of inputs—PV 1	2
Number of inputs—PV 2	1
Maximum capacity of the PV generat- or against ground	1000 nF
Limit value of the insulation resist- ance test between module array and ground (on delivery) 8)	100 kΩ
Adjustable range of insulation resist- ance test between module array and ground 7)	10-10,000 kΩ
Limit value and trip time of sudden residual fault current monitoring (on delivery)	30/300 mA/ms 60/150 mA/ms 90/40 mA/ms

DC input data	
Limit value and trip time of continuous residual fault current monitoring (on delivery)	300/300 mA/ms
Adjustable range of continuous residual current monitoring ⁷⁾	30-300 mA
Cyclic repetition of the insulation resistance test (on delivery)	24 h
Adjustable range for cyclic repetition of the insulation resistance test	-

DC input data battery	
Maximum voltage	700 V
Minimum voltage	160 V
Maximum current	14 A
Maximum output	3300 W
DC inputs	1

AC input/output data	
Rated power (P_{nom})	3000 W
Maximum output power	3000 W
Rated apparent power	3000 VA
Nominal mains voltage	3 ~ NPE 220 V/380 V 3 ~ NPE 230 V/400 V
Grounding systems	TN-S (allowed) TN-C-S (allowed) IT (not allowed)
Minimum mains voltage	154 V ¹⁾
Maximum mains voltage	280 V ¹⁾
Maximum output current	8 A
Rated output current (at 230 V)	4.3 A
Current (inrush) ⁶⁾	9.9 A/4 ms
Nominal frequency	50/60 Hz ¹⁾
Initial symmetrical short-circuit current/phase $I_{K''}$	8 A
Total harmonic distortion	< 3.5%
Power factor $\cos \phi$ ²⁾	0-1 (adjustable) 0.7-1 (recommended)
Maximum permitted grid impedance Z_{max} on PCC ⁴⁾	None
Maximum output fault current / duration	7.5 A/157 ms

AC output data PV Point/PV Point Comfort	
Maximum output power	4133 W (for 5 s)
Nominal output power	3000 W
Rated output current	13 A
Nominal mains voltage	1 ~ NPE 220 V/230 V/240 V
Nominal frequency	53/63 Hz ¹⁾
Switching time	~ 15 s
Power factor cos phi ²⁾	0 - 1

General data	
Maximum efficiency	98.1%
Europ. efficiency ($U_{mpp\ nom}$)	96.6%
Europ. efficiency ($U_{mpp\ max}$)	95.8%
Europ. efficiency ($U_{mpp\ min}$)	94.9%
Self-consumption at night	< 10 W
Cooling	Controlled forced-air ventilation
Ingress protection rating	IP 66
Dimensions H × W × D	530 × 474 × 165 mm
Weight	15.25 kg
Inverter topology	Non-insulated, no transformer
Permitted ambient temperature	-25 °C - +60 °C
Permissible humidity	0-100% (incl. condensation)
EMC emission class (in accordance with IEC 61000-6-2, IEC 61000-6-3)	B
DC/AC overvoltage category (in accordance with IEC 62109-1)	2/3
Pollution degree	2
Sound pressure level	36 dB(A) (ref. 20 µPA)
Protective class	1

Protective devices	
DC isolation measurement ⁹⁾	Warning/shutdown at $R_{ISO} < 100\ k\Omega$
Overload performance	Operating point shift, power limit
DC disconnect	Integrated
RCMU ⁹⁾	Integrated
RCMU classification	The software class of the safety platform(s) is defined as a class B control function (single-channel with periodic self-test) in accordance with IEC 60730 Annex H.

Protective devices	
Active anti-islanding method	Frequency point shift method
AFCI	Integrated
AFPE (AFCI) classification (according to IEC 63027) ⁹⁾	= F-I-AFPE-1-3-1 Full coverage Integrated AFPE 1 monitored string per input port 3 input ports per channel (MPP1: 2, MPP2: 1) 1 monitored channel

Data communication	
WiFi SMA-RP connection (FCC ID: QKWPILOT1/IC 12270A-PI-LOT1)	802.11b/g/n (WPA, WPA2) Frequency: 2.4 GHz
Ethernet (LAN)	RJ 45, 10/100 Mbit
Wired shutdown (WSD)	Max. 28 devices/WSD chain Max. distance between two devices = 100 m
Modbus RTU SunSpec (2x)	RS485 2-wire
Battery connection	Modbus O/RJ 45/12 V power supply
Voltage level of digital inputs	Low: min. 0 V-max. 1.8 V High: min. 4.5 V-max. 28.8 V
Input currents of digital inputs	depending on the input voltage; input resistance = 70 kOhm
Total power for digital output (with internal supply)	6 W at 12 V
Power per digital output (with external supply)	1 A at >12.5 V-24 V (max. 3 A in total)
Datalogger/web server	Integrated

**Fronius Symo
GEN24 4.0 SC /
4.0 Plus SC**

DC input data	
MPP voltage range (at rated power)	150 - 800 V
Maximum connected load ($P_{PV\ max}$)	
Total	6000 Wp
PV 1	6000 Wp
PV 2	6000 Wp
Maximum processable PV power	
Total	4180 Wp
PV 1	4180 Wp
PV 2	4180 Wp
Maximum input voltage (at 1000 W/m ² /-10 °C in an open circuit)	1000 V

DC input data	
Minimum input voltage	80 V
Feed-in start voltage in grid operation 5)	80 V
Maximum input current PV 1 PV 2	14 A 14 A
Maximum short circuit current for module array ($I_{SC\ PV}$) PV 1 PV 2	20 A 20 A
Maximum total short circuit current for module array ($I_{SC\ PV1} + I_{SC\ PV2} = I_{SC\ max}$)	40 A
Max. inverter backfeed current to the array 3) PV 1 PV 2	20 A 20 A
Number of inputs—PV 1	2
Number of inputs—PV 2	1
Maximum capacity of the PV generat- or against ground	1000 nF
Limit value of the insulation resist- ance test between module array and ground (on delivery) 8)	100 k Ω
Adjustable range of insulation resist- ance test between module array and ground 7)	10-10,000 k Ω
Limit value and trip time of sudden residual fault current monitoring (on delivery)	30/300 mA/ms 60/150 mA/ms 90/40 mA/ms
Limit value and trip time of continu- ous residual fault current monitoring (on delivery)	300/300 mA/ms
Adjustable range of continuous resid- ual current monitoring 7)	30-300 mA
Cyclic repetition of the insulation res- istance test (on delivery)	24 h
Adjustable range for cyclic repetition of the insulation resistance test	-

DC input data battery	
Maximum voltage	700 V
Minimum voltage	160 V
Maximum current	14 A
Maximum output	4300 W
DC inputs	1

AC input/output data	
Rated power (P_{nom})	4000 W
Maximum output power	4000 W
Rated apparent power	4000 VA
Nominal mains voltage	3 ~ NPE 220 V/380 V 3 ~ NPE 230 V/400 V
Grounding systems	TN-S (allowed) TN-C-S (allowed) IT (not allowed)
Minimum mains voltage	154 V ¹⁾
Maximum mains voltage	280 V ¹⁾
Maximum output current	8 A
Rated output current (at 230 V)	5.8 A
Current (inrush) ⁶⁾	9.9 A/4 ms
Nominal frequency	50/60 Hz ¹⁾
Initial symmetrical short-circuit current/phase $I_{K''}$	8 A
Total harmonic distortion	< 3.5%
Power factor $\cos \phi$ ²⁾	0-1 (adjustable) 0.7-1 (recommended)
Maximum permitted grid impedance Z_{max} on PCC ⁴⁾	None
Maximum output fault current / duration	7.5 A/157 ms

AC output data PV Point/PV Point Comfort	
Maximum output power	4133 W (for 5 s)
Nominal output power	3000 W
Rated output current	13 A
Nominal mains voltage	1 ~ NPE 220 V/230 V/240 V
Nominal frequency	53/63 Hz ¹⁾
Switching time	~ 15 s
Power factor $\cos \phi$ ²⁾	0 - 1

General data	
Maximum efficiency	98.1%
Europ. efficiency ($U_{mpp\ nom}$)	97.1%
Europ. efficiency ($U_{mpp\ max}$)	96.5%
Europ. efficiency ($U_{mpp\ min}$)	95.7%
Self-consumption at night	< 10 W
Cooling	Controlled forced-air ventilation
Ingress protection rating	IP 66

General data	
Dimensions H × W × D	530 × 474 × 165 mm
Weight	15.25 kg
Inverter topology	Non-insulated, no transformer
Permitted ambient temperature	-25 °C - +60 °C
Permissible humidity	0-100% (incl. condensation)
EMC emission class (in accordance with IEC 61000-6-2, IEC 61000-6-3)	B
DC/AC overvoltage category (in accordance with IEC 62109-1)	2/3
Pollution degree	2
Sound pressure level	36 dB(A) (ref. 20 µPA)
Protective class	1

Protective devices	
DC isolation measurement ⁹⁾	Warning/shutdown at $R_{ISO} < 100 \text{ k}\Omega$
Overload performance	Operating point shift, power limit
DC disconnect	Integrated
RCMU ⁹⁾	Integrated
RCMU classification	The software class of the safety platform(s) is defined as a class B control function (single-channel with periodic self-test) in accordance with IEC 60730 Annex H.
Active anti-islanding method	Frequency point shift method
AFCI	Integrated
AFPE (AFCI) classification (according to IEC 63027) ⁹⁾	= F-I-AFPE-1-3-1 Full coverage Integrated AFPE 1 monitored string per input port 3 input ports per channel (MPP1: 2, MPP2: 1) 1 monitored channel

Data communication	
WiFi SMA-RP connection (FCC ID: QKWPILOT1/IC 12270A-PI- LOT1)	802.11b/g/n (WPA, WPA2) Frequency: 2.4 GHz
Ethernet (LAN)	RJ 45, 10/100 Mbit
Wired shutdown (WSD)	Max. 28 devices/WSD chain Max. distance between two devices = 100 m
Modbus RTU SunSpec (2x)	RS485 2-wire
Battery connection	Modbus O/RJ 45/12 V power supply

Data communication	
Voltage level of digital inputs	Low: min. 0 V-max. 1.8 V High: min. 4.5 V-max. 28.8 V
Input currents of digital inputs	depending on the input voltage; input resistance = 70 kOhm
Total power for digital output (with internal supply)	6 W at 12 V
Power per digital output (with external supply)	1 A at >12.5 V-24 V (max. 3 A in total)
Datalogger/web server	Integrated

**Fronius Symo
GEN24 5.0 SC /
5.0 Plus SC**

DC input data	
MPP voltage range (at rated power)	190 - 800 V
Maximum connected load ($P_{PV \max}$)	
Total	7500 W _p
PV 1	6500 W _p
PV 2	6500 W _p
Maximum processable PV power	
Total	5200 W _p
PV 1	5200 W _p
PV 2	5200 W _p
Maximum input voltage (at 1000 W/m ² /-10 °C in an open circuit)	1000 V
Minimum input voltage	80 V
Feed-in start voltage in grid operation ⁵⁾	80 V
Maximum input current	
PV 1	14 A
PV 2	14 A
Maximum short circuit current for module array ($I_{SC \text{ PV}}$)	
PV 1	20 A
PV 2	20 A
Maximum total short circuit current for module array ($I_{SC \text{ PV1}} + I_{SC \text{ PV2}} = I_{SC \text{ max}}$)	40 A
Max. inverter backfeed current to the array ³⁾	
PV 1	20 A
PV 2	20 A
Number of inputs—PV 1	2
Number of inputs—PV 2	1
Maximum capacity of the PV generator against ground	1000 nF

DC input data	
Limit value of the insulation resistance test between module array and ground (on delivery) ⁸⁾	100 kΩ
Adjustable range of insulation resistance test between module array and ground ⁷⁾	10-10,000 kΩ
Limit value and trip time of sudden residual fault current monitoring (on delivery)	30/300 mA/ms 60/150 mA/ms 90/40 mA/ms
Limit value and trip time of continuous residual fault current monitoring (on delivery)	300/300 mA/ms
Adjustable range of continuous residual current monitoring ⁷⁾	30-300 mA
Cyclic repetition of the insulation resistance test (on delivery)	24 h
Adjustable range for cyclic repetition of the insulation resistance test	-

DC input data battery	
Maximum voltage	700 V
Minimum voltage	160 V
Maximum current	14 A
Maximum output	5300 W
DC inputs	1

AC input/output data	
Rated power (P_{nom})	5000 W
Maximum output power	5000 W
Rated apparent power	5000 VA
Nominal mains voltage	3 ~ NPE 220 V/380 V 3 ~ NPE 230 V/400 V
Grounding systems	TN-S (allowed) TN-C-S (allowed) IT (not allowed)
Minimum mains voltage	154 V ¹⁾
Maximum mains voltage	280 V ¹⁾
Maximum output current	8 A
Rated output current (at 230 V)	7.2 A
Current (inrush) ⁶⁾	9.9 A/4 ms
Nominal frequency	50/60 Hz ¹⁾
Initial symmetrical short-circuit current/phase $I_{K''}$	8 A
Total harmonic distortion	< 3.5%

AC input/output data	
Power factor $\cos \phi$ ²⁾	0-1 (adjustable) 0.7-1 (recommended)
Maximum permitted grid impedance Z_{\max} on PCC ⁴⁾	None
Maximum output fault current / duration	7.5 A/157 ms

AC output data PV Point/PV Point Comfort	
Maximum output power	4133 W (for 5 s)
Nominal output power	3000 W
Rated output current	13 A
Nominal mains voltage	1 ~ NPE 220 V/230 V/240 V
Nominal frequency	53/63 Hz ¹⁾
Switching time	~ 15 s
Power factor $\cos \phi$ ²⁾	0 - 1

General data	
Maximum efficiency	98.1%
Europ. efficiency ($U_{\text{mpp nom}}$)	97.4%
Europ. efficiency ($U_{\text{mpp max}}$)	96.9%
Europ. efficiency ($U_{\text{mpp min}}$)	96.1%
Self-consumption at night	< 10 W
Cooling	Controlled forced-air ventilation
Ingress protection rating	IP 66
Dimensions H × W × D	530 × 474 × 165 mm
Weight	15.25 kg
Inverter topology	Non-insulated, no transformer
Permitted ambient temperature	-25 °C - +60 °C
Permissible humidity	0-100% (incl. condensation)
EMC emission class (in accordance with IEC 61000-6-2, IEC 61000-6-3)	B
DC/AC overvoltage category (in accordance with IEC 62109-1)	2/3
Pollution degree	2
Sound pressure level	36 dB(A) (ref. 20 μ PA)
Protective class	1

Protective devices	
DC isolation measurement ⁹⁾	Warning/shutdown at $R_{\text{ISO}} < 100 \text{ k}\Omega$

Protective devices	
Overload performance	Operating point shift, power limit
DC disconnect	Integrated
RCMU ⁹⁾	Integrated
RCMU classification	The software class of the safety platform(s) is defined as a class B control function (single-channel with periodic self-test) in accordance with IEC 60730 Annex H.
Active anti-islanding method	Frequency point shift method
AFCI	Integrated
AFPE (AFCI) classification (according to IEC 63027) ⁹⁾	= F-I-AFPE-1-3-1 Full coverage Integrated AFPE 1 monitored string per input port 3 input ports per channel (MPP1: 2, MPP2: 1) 1 monitored channel

Data communication	
WiFi SMA-RP connection (FCC ID: QKWPILOT1/IC 12270A-PILOT1)	802.11b/g/n (WPA, WPA2) Frequency: 2.4 GHz
Ethernet (LAN)	RJ 45, 10/100 Mbit
Wired shutdown (WSD)	Max. 28 devices/WSD chain Max. distance between two devices = 100 m
Modbus RTU SunSpec (2x)	RS485 2-wire
Battery connection	Modbus O/RJ 45/12 V power supply
Voltage level of digital inputs	Low: min. 0 V-max. 1.8 V High: min. 4.5 V-max. 28.8 V
Input currents of digital inputs	depending on the input voltage; input resistance = 70 kOhm
Total power for digital output (with internal supply)	6 W at 12 V
Power per digital output (with external supply)	1 A at >12.5 V-24 V (max. 3 A in total)
Datalogger/web server	Integrated

WLAN

Frequency range	2412 - 2462 MHz
Channels / power used	Channel: 1-11 b,g,n HT20 Channel: 3-9 HT40 <18 dBm

Modulation	802.11b: DSSS (1Mbps DBPSK, 2Mbps DQPSK, 5.5/11Mbps CCK) 802.11g: OFDM (6/9Mbps BPSK, 12/18Mbps QPSK, 24/36Mbps 16-QAM, 48/54Mbps 64-QAM) 802.11n: OFDM (6.5 BPSK, QPSK, 16-QAM, 64-QAM)
------------	--

Technical data of surge protection device DC SPD type 1+2 GEN24

General data	
Continuous operating current (I_{cpv})	< 0.1 mA
Rated discharge current (I_n) - 15 x 8/20 μ s pulses	20 kA
Lightning surge current (I_{imp}) Max. discharge capacity @ 10/350 μ s	6.25 kA
Protection level (U_p) (star-shaped mounting)	4 kV
Short circuit strength PV (I_{scpv})	15 kA

Disconnecter	
Thermal disconnecter	Integrated
External fuse	None

Mechanical properties	
Disconnection indicator	Mechanical indicator (red)
Remote communication of the connection interruption	Output on the changeover contact
Housing material	Thermoplastic UL-94-V0
Test standards	IEC 61643-31 / DIN EN 50539-11 UL1449 ed.4 / VDE 0185-305-3 Bbl. 5

Explanation of footnotes

- 1) The values provided are standard values. If required, the inverter is customized for a specific country.
- 2) Depending on the country setup or device-specific settings (ind. = inductive; cap. = capacitive).
- 3) Maximum current from a defective PV module to all other PV modules. From the inverter itself to the PV side of the inverter, this is 0 A.
- 4) Assured by the electrical design of the inverter.
- 5) For backup power mode (PV Point) without battery, a min. voltage of 150 V is required.
- 6) Peak current when turning on the inverter.
- 7) The values provided are standard values. These values must be adjusted according to requirements and PV output.

- 8) The value provided is a max. value. If this value is exceeded, this may impair the function.
- 9) Software class B (single-channel with periodic self-test) according to IEC 60730-1 Annex H.

Integrated DC disconnect

General data	
Product name	Benedict LSA32 E 8229
Rated insulation voltage	1000 V _{DC}
Rated impulse withstand voltage	6 kV
Suitability for insulation	Yes, DC only
Utilization category and/or PV utilization category	according to IEC/EN 60947-3 utilization category DC-PV2
Rated short-time withstand current (I _{cw})	Rated short-time withstand current (I _{cw}): 1000 A
Rated short-circuit capacity (I _{cm})	Rated short-circuit capacity (I _{cm}): 1000 A

Rated operating current and rated breaking capacity				
Rated operating voltage (U _e)	Rated operating current (I _e)	I _(make) / I _(break)	Rated operating current (I _e)	I _(make) / I _(break)
300 V _{DC}	27 A	108 A	47 A	188 A
400 V _{DC}	20 A	80 A	45 A	180 A
500 V _{DC}	14 A	56 A	38 A	152 A
600 V _{DC}	11.5 A	46 A	33 A	132 A
700 V _{DC}	7.5 A	30 A	28 A	112 A
800 V _{DC}	5.75 A	23 A	23 A	92 A
900 V _{DC}	4.75 A	19 A	20 A	80 A
1 000 V _{DC}	4 A	16 A	13 A	52 A
Number of pins	1	1	2	2

System circuit diagrams

Fronius Symo GEN24 and Fronius Reserva

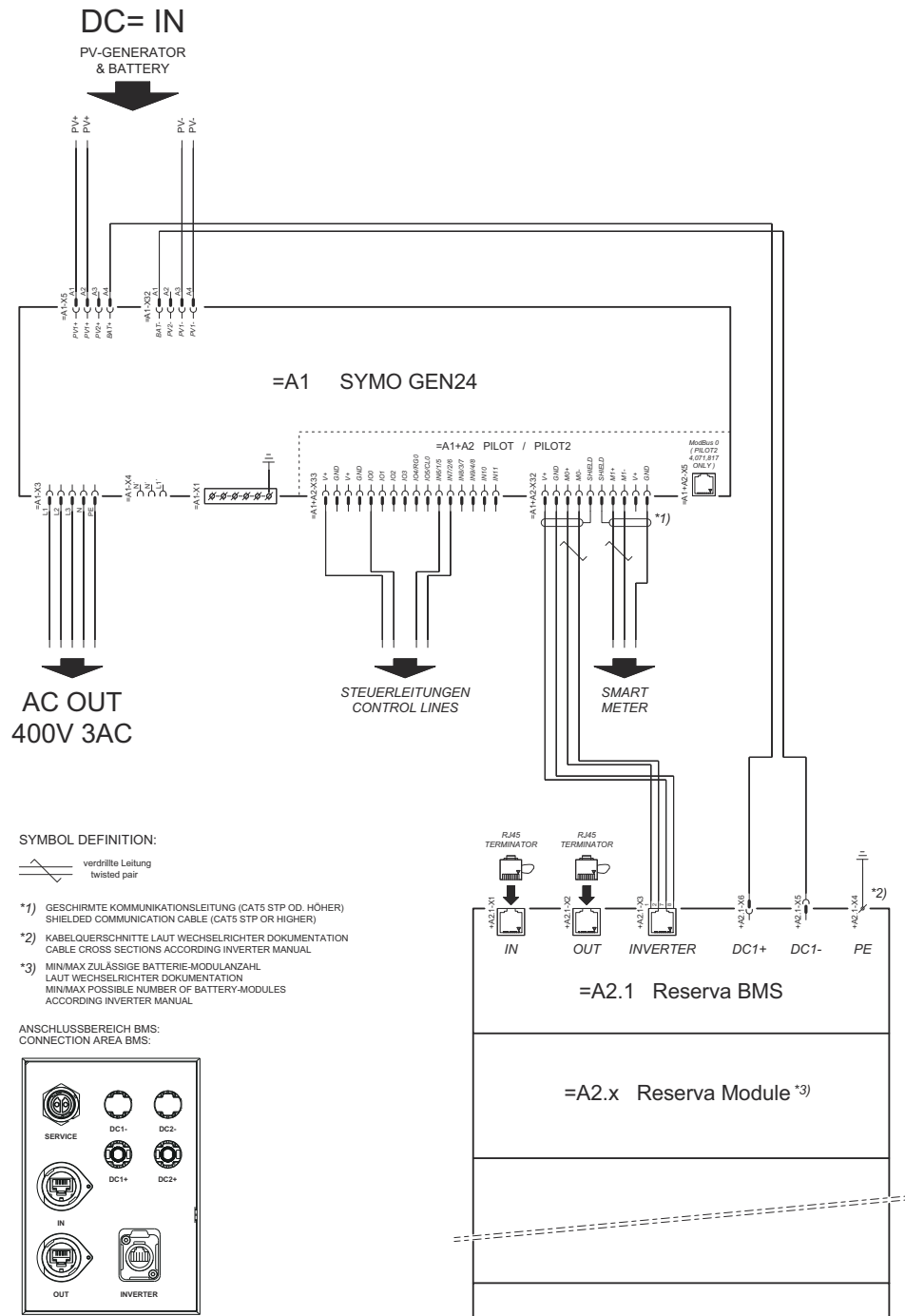

Fronius Symo GEN24 with Fronius Reserva connected in parallel

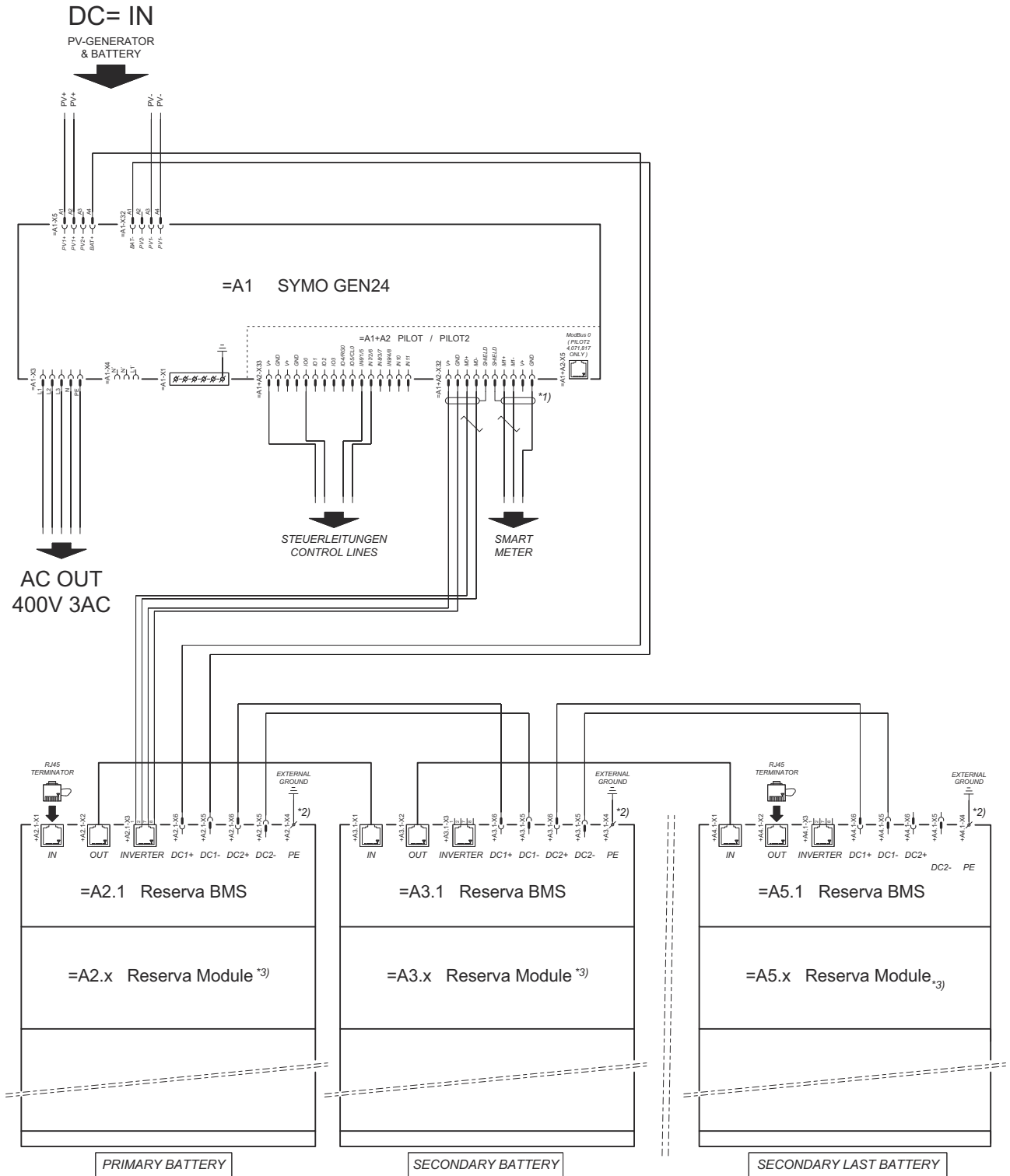

SYMBOL DEFINITION:

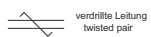

*1) GESCHIRMTE KOMMUNIKATIONSLEITUNG (CAT5 STP OD. HÖHER)
SHIELDED COMMUNICATION CABLE (CAT5 STP OR HIGHER)

*2) KABELQUERSCHNITTE LAUT WECHSELRICHTER DOKUMENTATION
CABLE CROSS SECTIONS ACCORDING INVERTER MANUAL

*3) MIN/MAX ZULÄSSIGE BATTERIE-MODULANZAHL
LAUT WECHSELRICHTER DOKUMENTATION
MIN/MAX POSSIBLE NUMBER OF BATTERY-MODULES
ACCORDING INVERTER MANUAL

**ANSCHLUSSBEREICH BMS:
CONNECTION AREA BMS:**

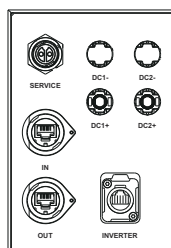

Fronius Symo GEN24 and Fronius Reserva Pro

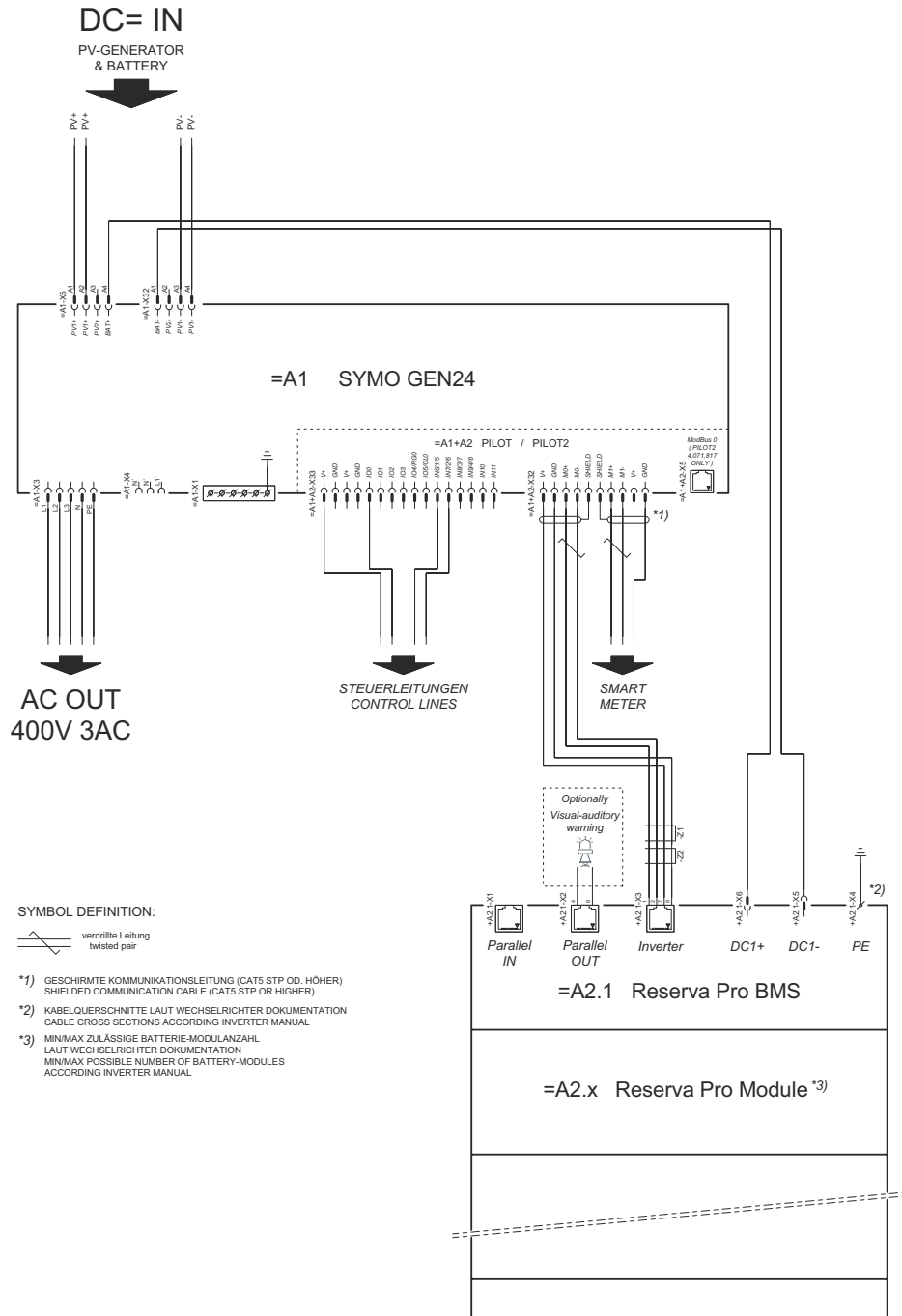

Fronius Symo GEN24 with Fronius Reserva Pro connected in parallel

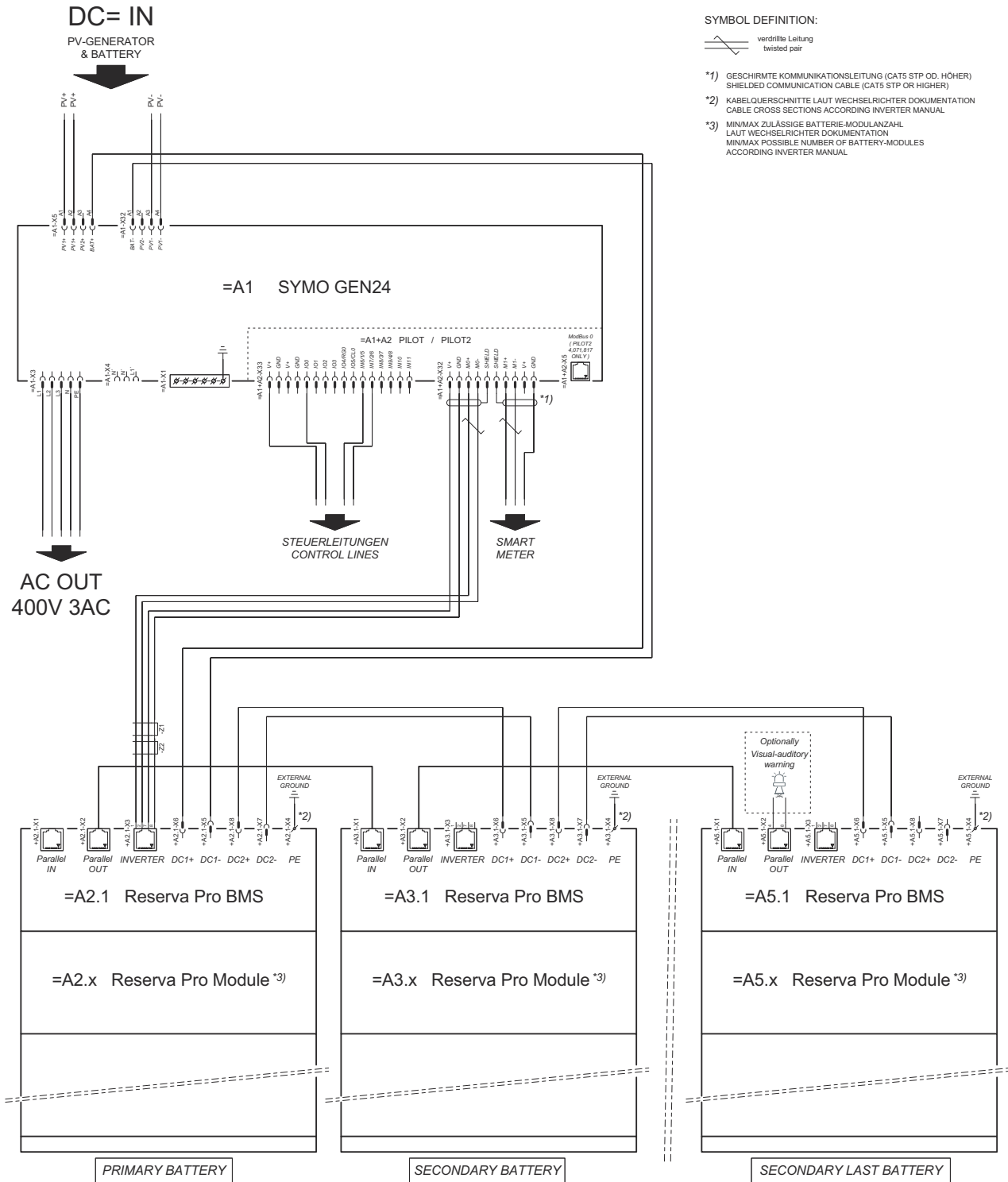

Fronius Symo GEN24 and BYD Battery-Box Premium HV

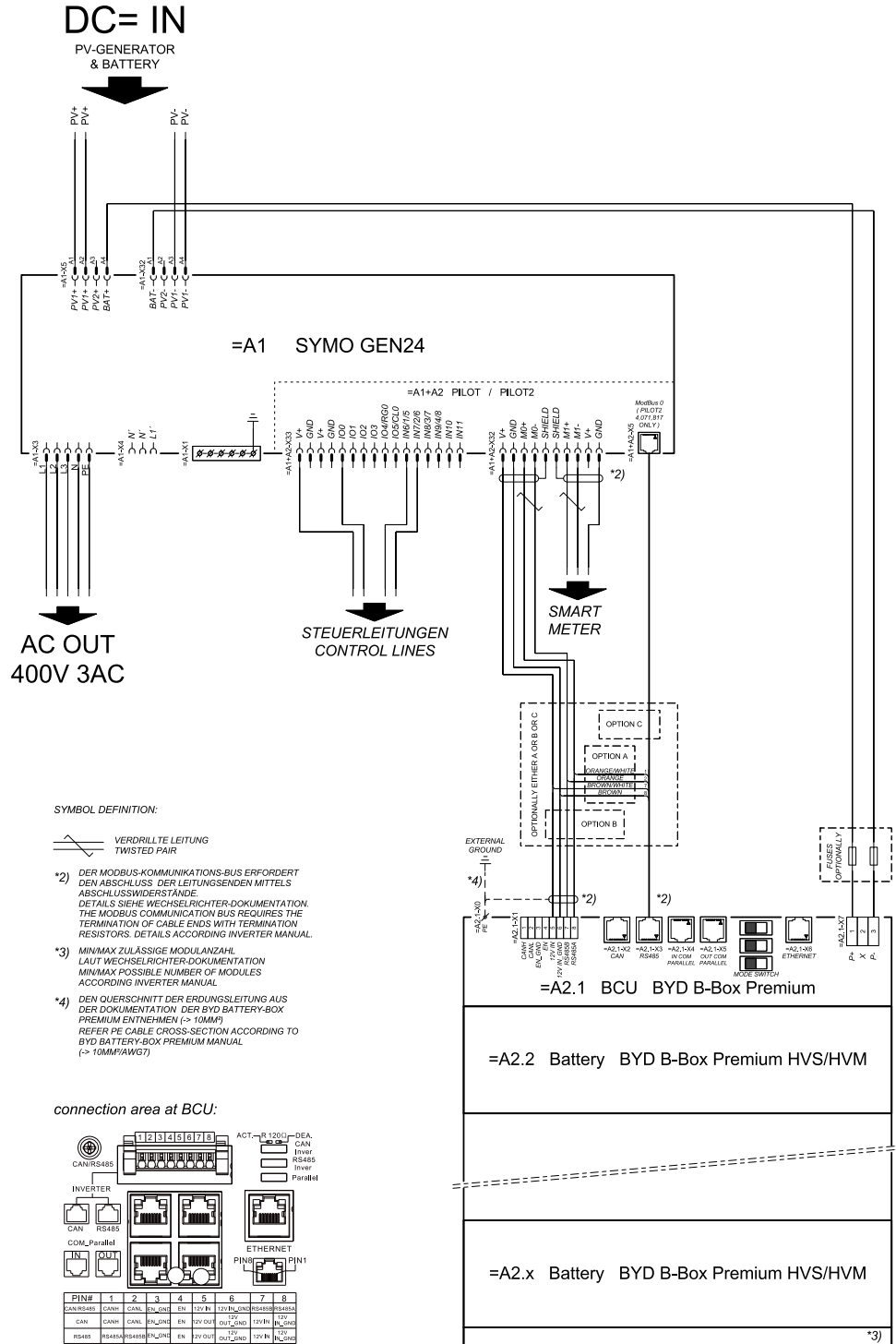

Fronius Symo GEN24 with two BYD Battery-Box Premium HV connected in parallel

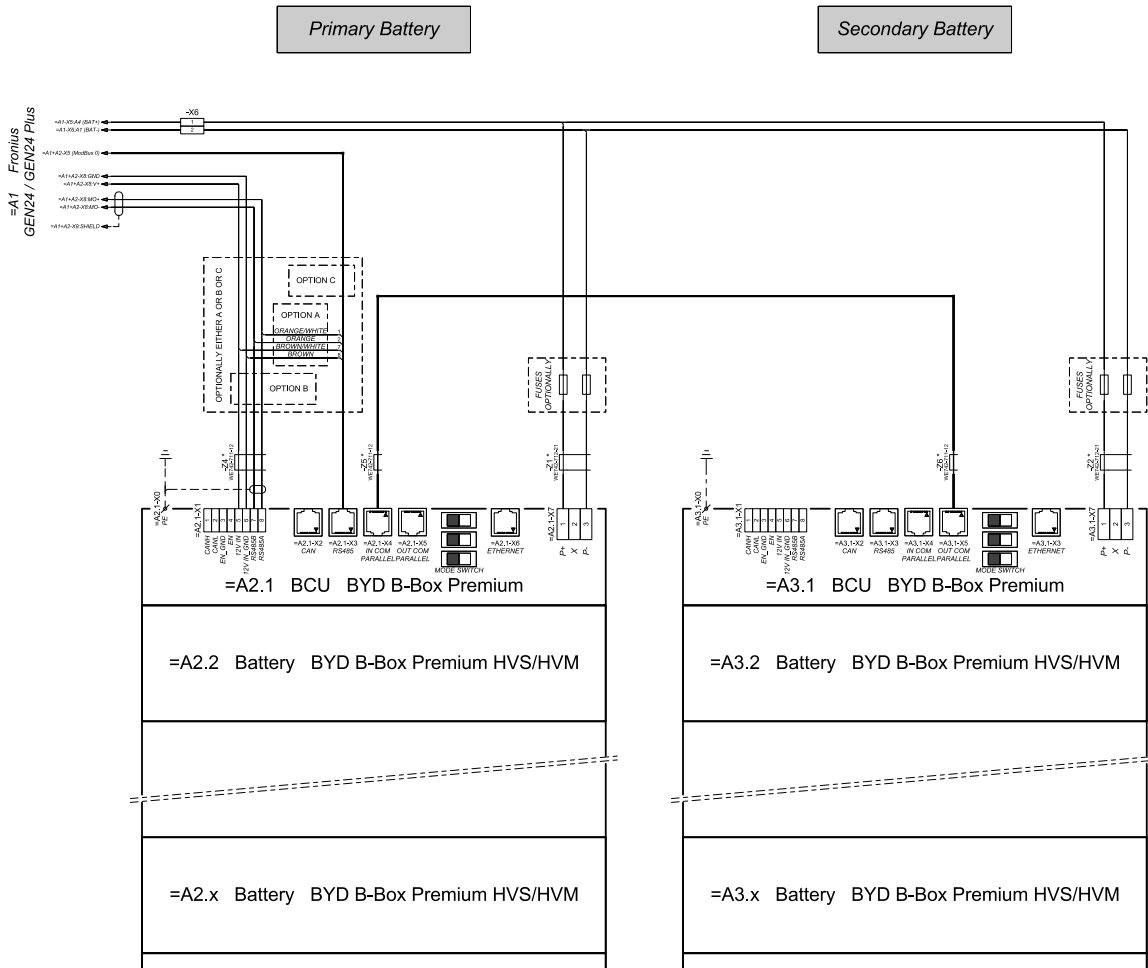

connection area at BCU's:

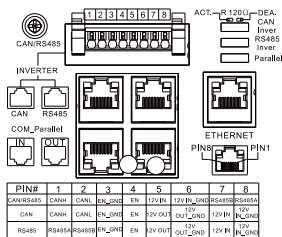

* The ferrite cores -Z1 to -Z8 are only mandatory for storage installations in Italy!
 Certified ferrites for DC connection path: -Z1 and -Z2: WE742-712-21, manufacturer: Würth
 Certified ferrites for communication connection: -Z4 to -Z6: WE742-711-12, manufacturer: Würth

Fronius Symo GEN24 with three BYD Battery-Box Premium HV connected in parallel

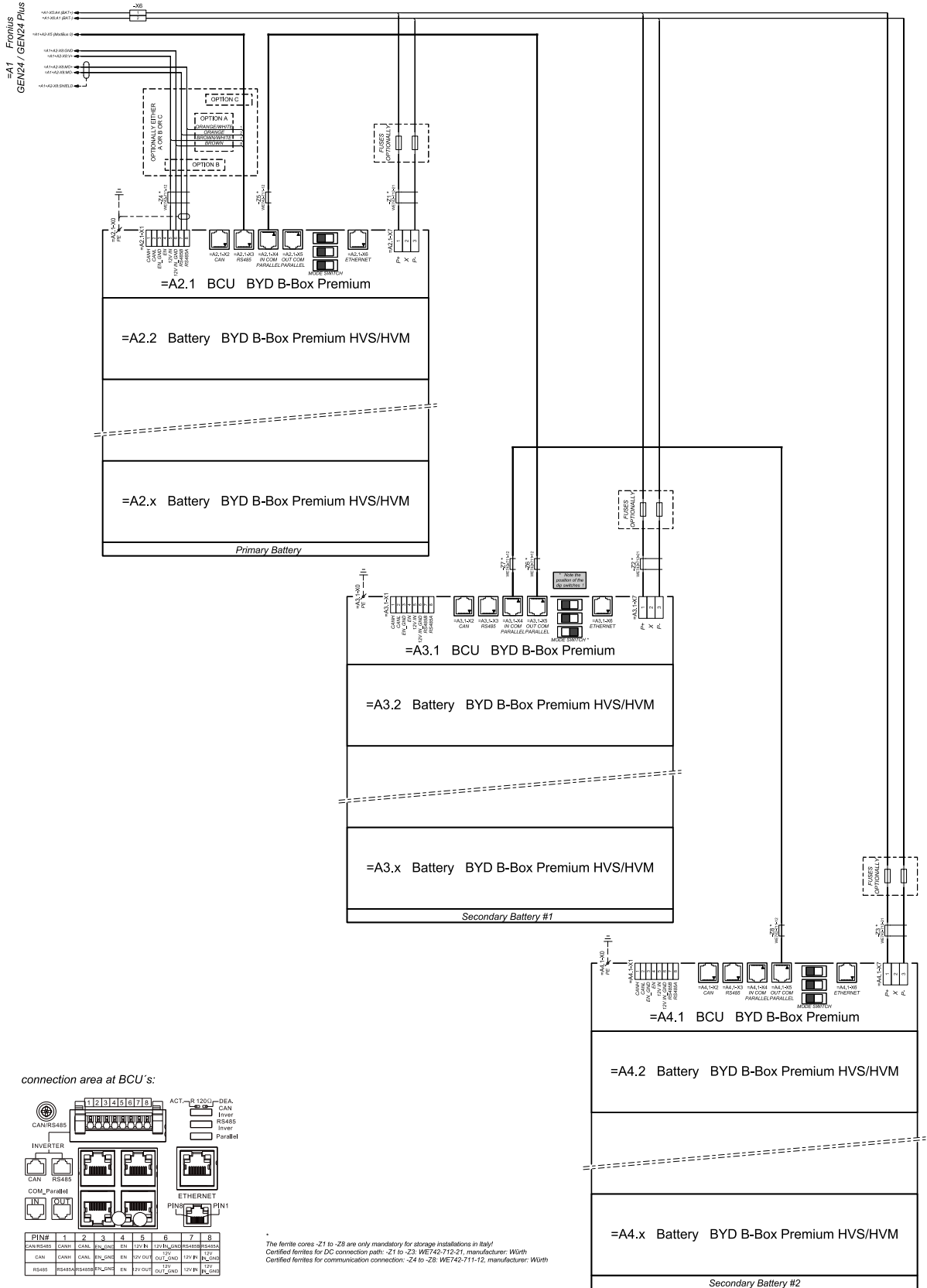

Fronius Symo GEN24 and BYD Battery-Box HVS +/HVM+

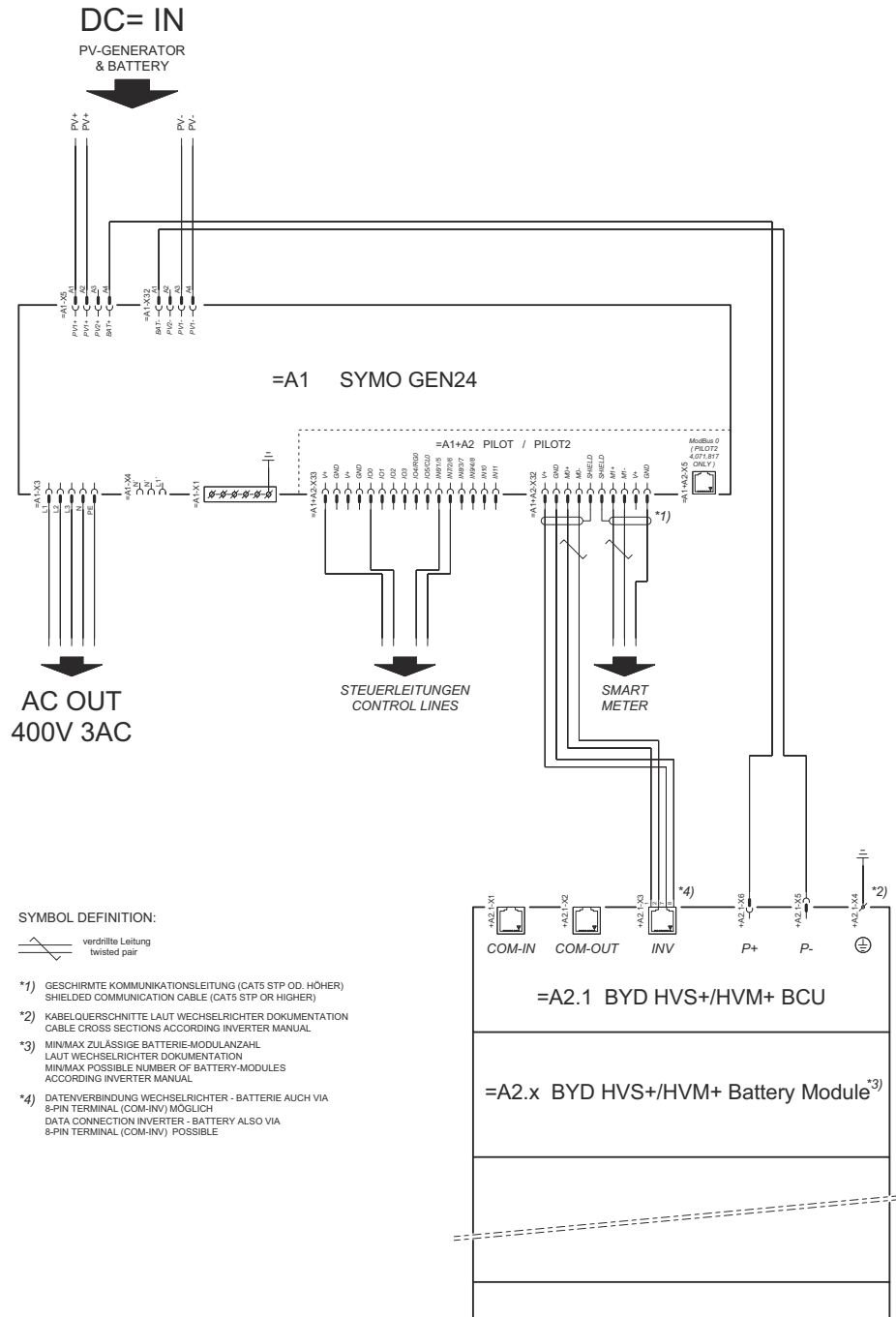

Fronius Symo GEN24 with BYD Battery-Box HVS +/HVM+ connected in parallel

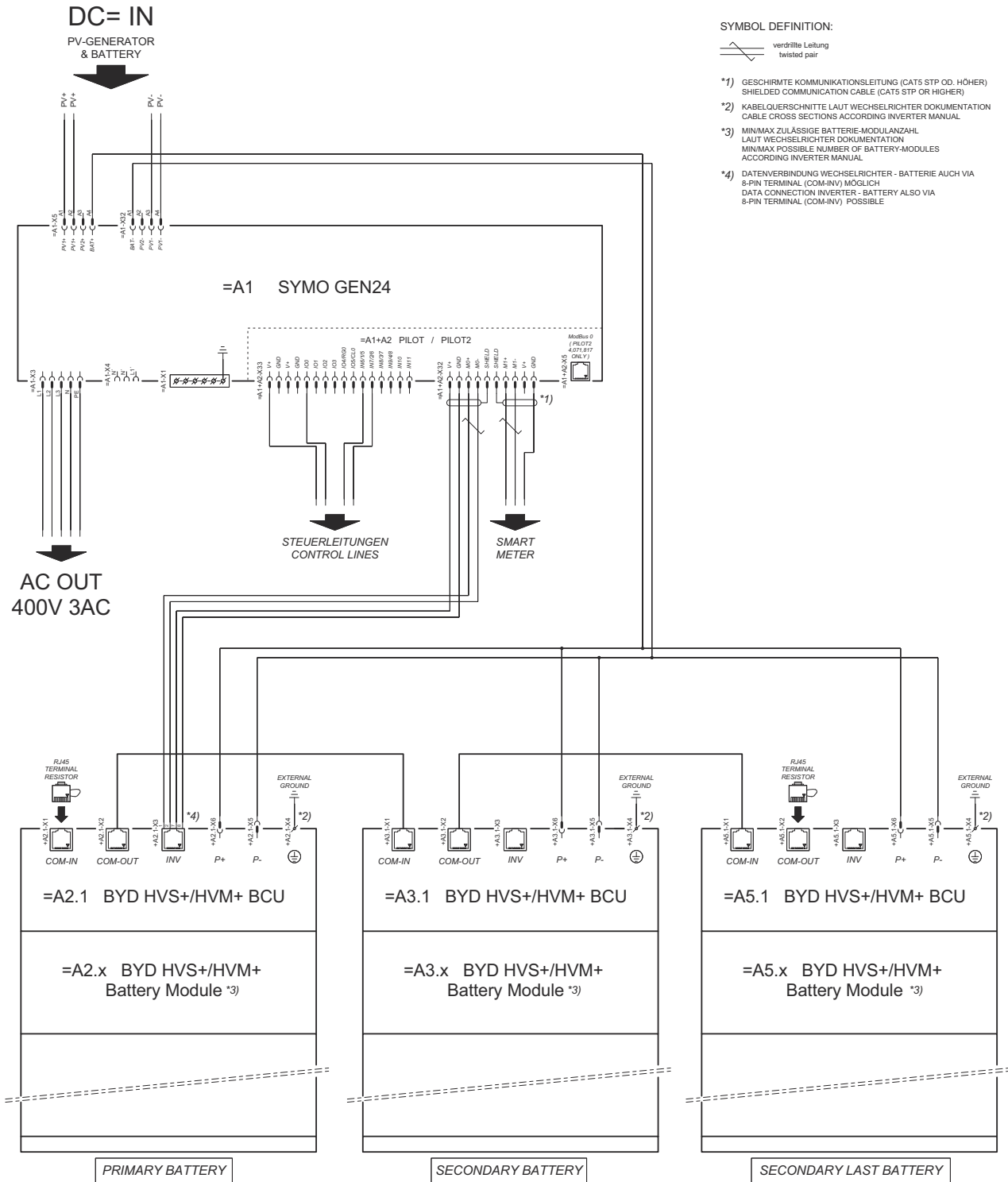

Fronius Symo GEN24 and LG FLEX

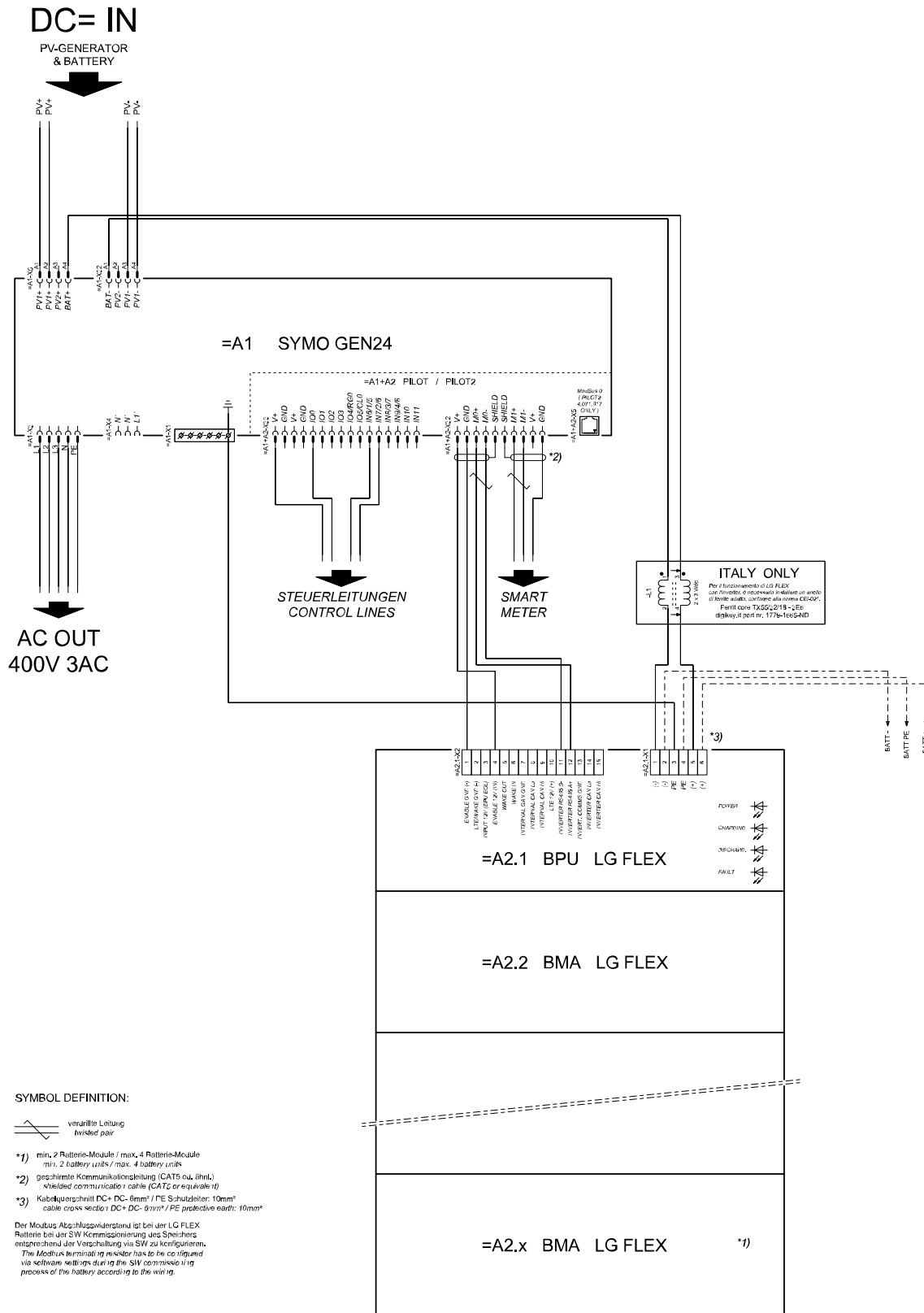

Surge protection device (SPD)

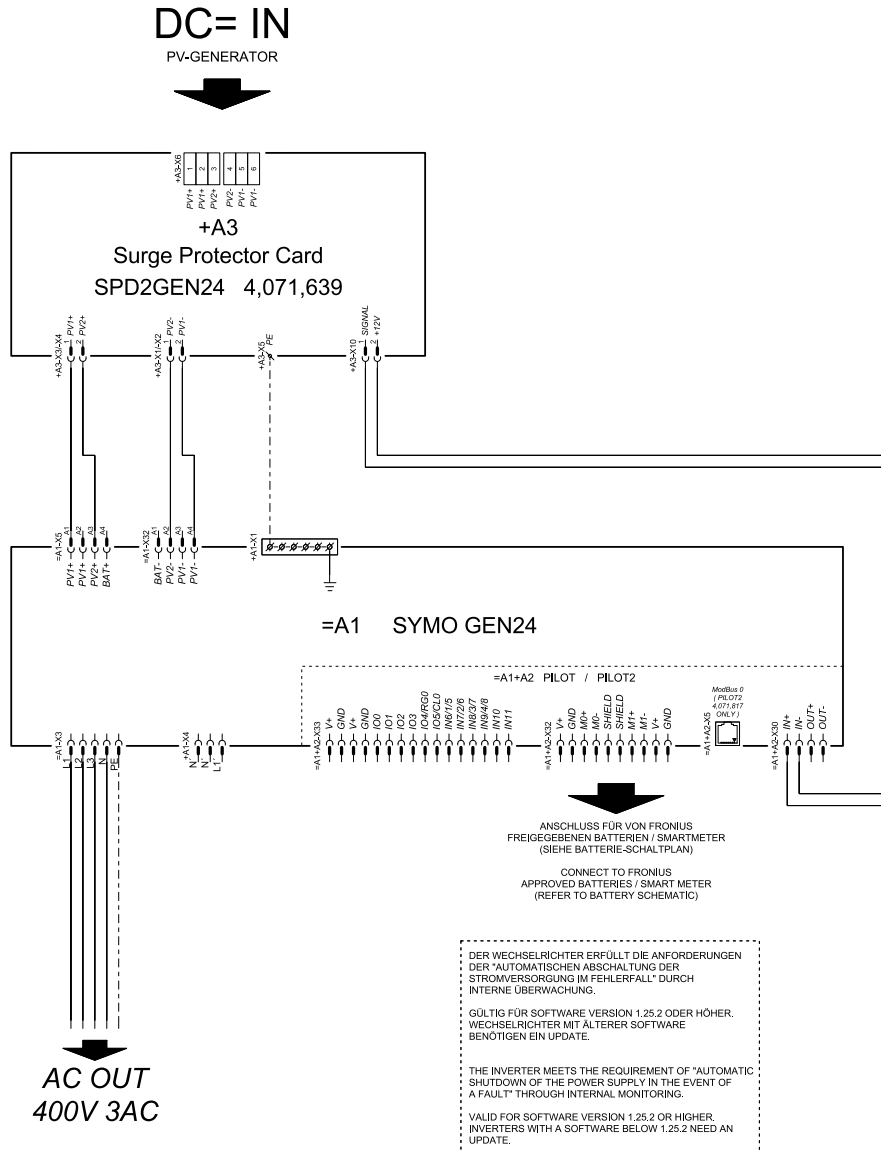

Circuit diagrams—PV Point

Emergency power terminal—PV Point (OP)

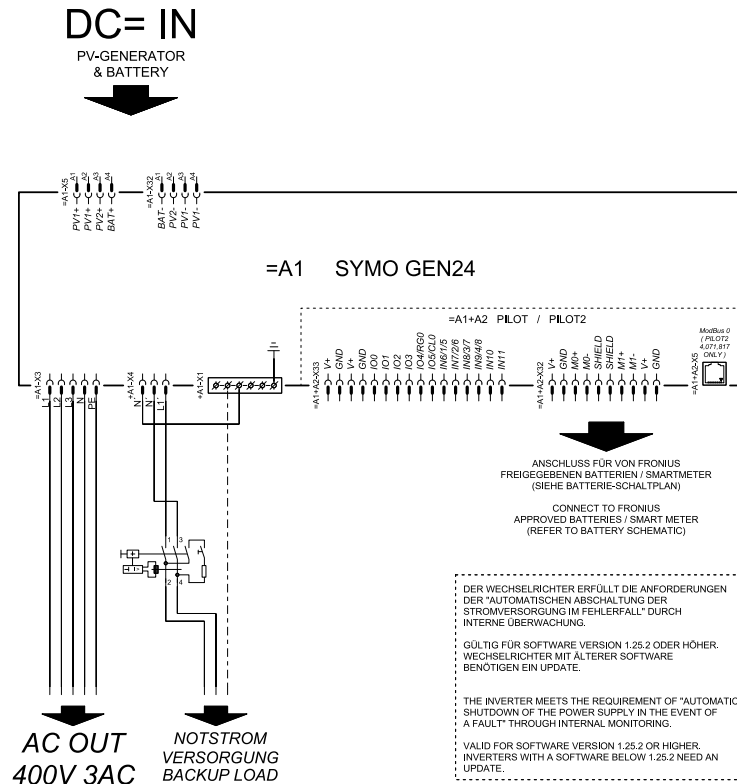

Circuit diagram - PV Point (OP) Australia

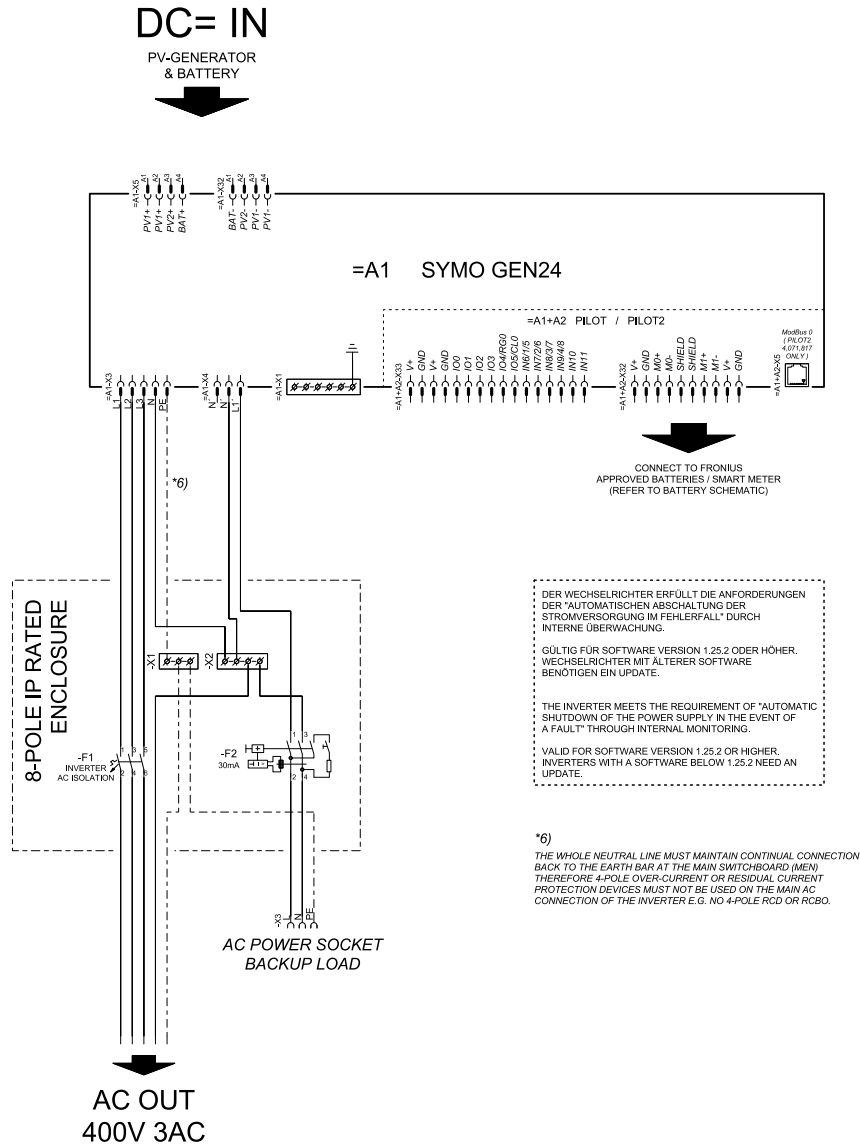

Backup power terminal - PV Point (OP) with battery only for France

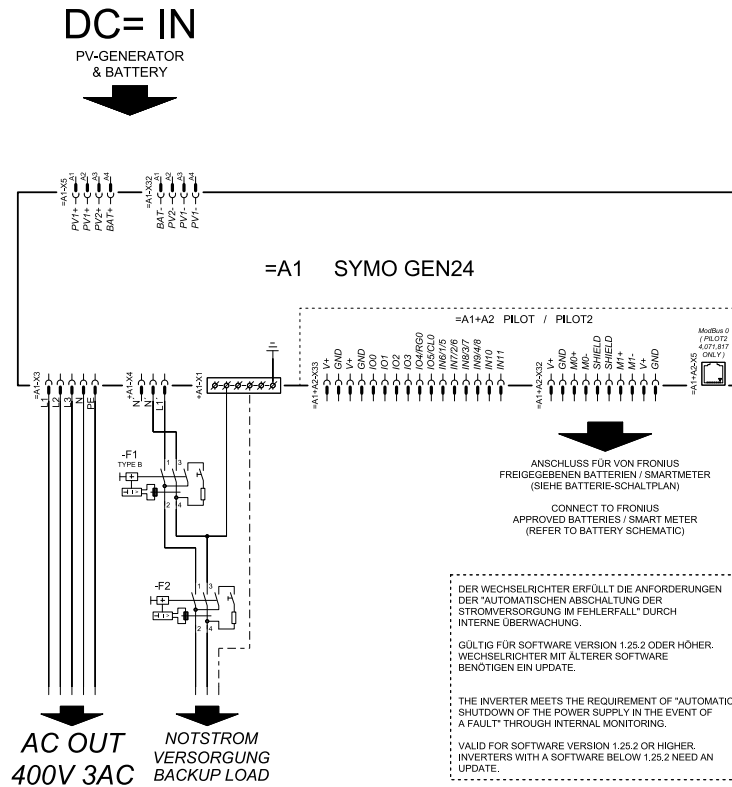

PV Point Comfort

DC= IN

PV-GENERATOR
& BATTERY

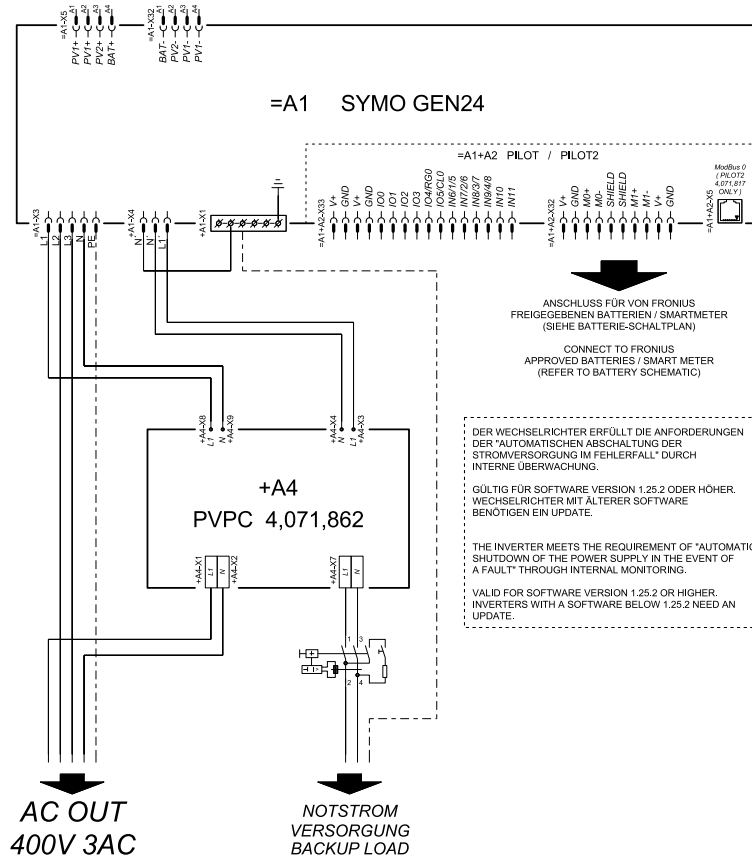

Dimensions of the inverter

Fronius Symo GEN24 SC / Fronius Symo GEN24 Plus SC

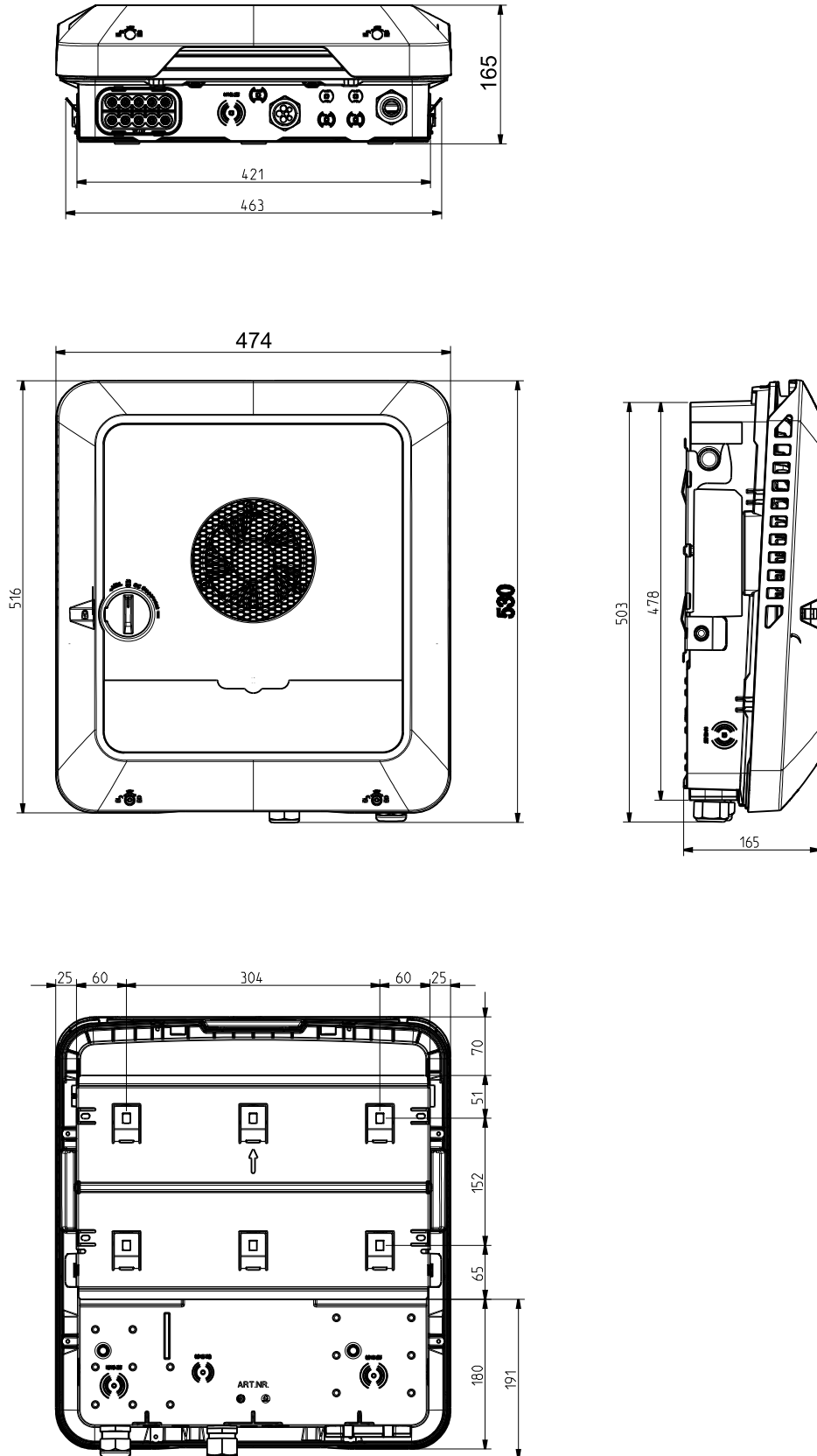



fronius.com/en/solar-energy/installers-partners/products-solutions/monitoring-digital-tools

**MONITORING &
DIGITAL TOOLS**

Fronius International GmbH

Froniusstraße 1
4643 Pettenbach
Austria
contact@fronius.com
www.fronius.com

At www.fronius.com/contact you will find the contact details of all Fronius subsidiaries and Sales & Service Partners.