

Produkt: **elko-flex
N18**

Type: **EVN18**
Datum: **15.01.2024**

Kunde:

Projekt:

Referenz:

Zeichnung



EVN 4 .. EVN 100, EVN 140

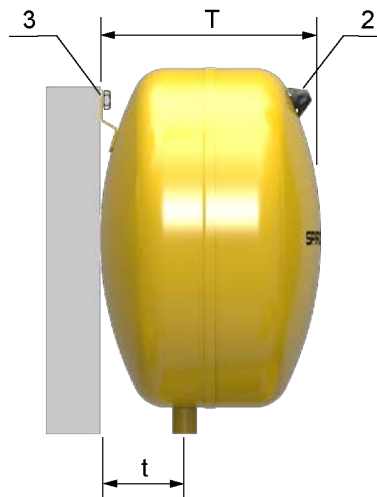

EVN 4 .. EVN 100

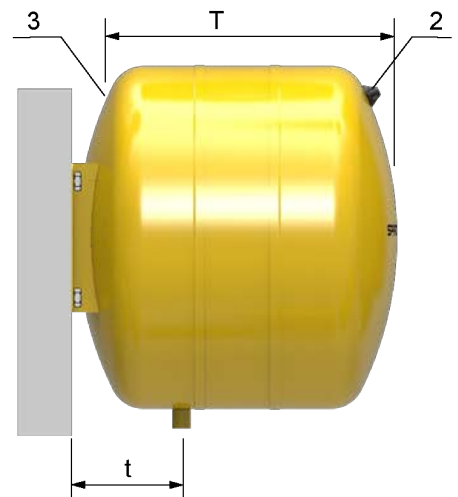

EVN 140

Auslegekriterien

| | | |
|--|---------------------|-------|
| Tested in accordance with: | PED 2014/68/EU | |
| Max. safety temperature of the system without/with cooling vessel: | 90/110 | °C |
| Min. Temperatur: | 0 | °C |
| Max. Temperatur: | 70 | °C |
| Max. Betriebsdruck: | 3 | bar-g |
| Permissible medium: | Water, Water/Glycol | |
| Farbe: | RAL 1003 | |

Abmessungen

| | |
|----------------------|--------------------|
| D: | 360 mm |
| T: | 237 mm |
| t: | 80 mm |
| Connection | Rp3/4 |
| 1 | Expansion pipe |
| 2 | Gas pressure valve |
| 3 | Wall mount (1) |
| Volumen: | 18 ltr |
| Leergewicht (circa): | 3,8 kg |

Änderungen vorbehalten