

Residual Current Devices

Application guide



Author:
Ing. František Štěpán

EATON

Powering Business Worldwide

Evolution of protection devices - we create trends



2009

Moeller promoted a first digital RCCB and RCBO



1980

Launch of the new frame size 45 mm instead of standard 80 mm



1965

F&G started production of modern permanent magnet relay (PMR)



1957

Dr. Biegelmeier - patent for the RCCB

2016

Eaton startet with AFDD



2016

1957

Safety

Reliability

Innovation

EATON

Powering Business Worldwide

Table

1. Introduction	2
2. Effects of electric current on the human body	3
3. Types and characteristics of residual current devices (RCDs)	5
3.1. Functional principle of RCD	5
3.2. Parameters of RCD	6
3.3. Dependence on supply voltage	7
3.4. Testing device (TEST)	9
3.5. Resistance to short-circuit and overload	9
3.6. Selectivity of RCDs	10
3.7. Time delay - tripping characteristics (instantaneous, G, S)	11
3.8. Sensitivity to various types of residual currents (types AC, A, U, F, B, Bf, B+, B+)	13
3.9. Operating conditions	15
3.9.1 Ambient temperature	15
3.9.2 Rated voltage	15
3.10. Circuits with variable frequency	16
3.11. Marking	17
3.12. Design of RCDs	18
3.12.1 Residual current devices (RCD)	19
3.12.2 Residual current circuit breakers (RCCB)	19
3.12.3 Residual current circuit breakers with overload protection (RCBO)	20
3.12.4 Circuit breaker with integrated residual current protection (CBR)	20
3.12.5 Modular residual current devices (MRCD)	21
3.12.6 Residual current monitors (RCM)	21
3.13. Digital RCDs	22
4. Protection against electric shock	23
4.1. Protection in case of fault	23
4.1.1. TN networks	24
4.1.2. TT networks	24
4.1.3. IT networks	25
4.2. Additional protection by RCD with $I_{\Delta n} \leq 30$ mA	26
5. Protection against fire risk	27
5.1. Protection against leaking currents	27
5.2. Protection against serial arc (AFDD)	28
6. Limits of applicability of RCDs	29
7. Reliability of RCDs	29
7.1. Operational reliability	29
7.2. Regular servicing	30
8. Measurements of RCDs during verifications	31
9. Connection in installations	32
9.1. Incomplete number of live conductors	32
9.2. Constant leaking currents	32
9.3. Grouping of circuits behind one RCD	33
9.4. Coordination with surge protective devices (EMC)	34
9.5. Application of RCD types AC, A and B	35
10. Problem solving	39
10.1. Connection errors	39
10.2. Automatic and remote activation	41
Literature	44

1. Introduction

For correct application of residual current devices (RCDs) it is necessary to know the principle of function and basic rules of their application. The actual principle of differential protection was described as early as in 1928 as a solution for protection in case of contact with high voltage. First actually functioning residual current devices for use in low-voltage installations were designed in 1940s with focus on protection in the event of insulation failure. Their sensitivity was around 100 mA and in 1950s it could be raised up to around 30 mA, which was already sufficient to prevent a fatal injury of persons in contact with live parts.

Installations fitted with residual current devices started to face problems with unwanted tripping due to surge voltage during storms. A solution was presented by Dr. Gottfried Biegelmeier, who had a residual current device patented with an accumulator patented in 1957. It utilized a delaying circuit with postponed tripping by at least 10 ms, sufficient for all surge voltage in the network to subside (type G; from German das Gewitter = thunderstorm). This was a solution to unwanted tripping of residual current devices during thunderstorms. All nowadays applied delayed types (G, S) utilize this principle.

In 1960s, protection with sensitive residual current devices, providing protection even in case of direct contact with live parts, started to become widely applied. At first, they started to be applied in bathrooms, outdoor installations and agriculture, and later become mandatory for all installation with layman's operation. This measure demonstrably reduced the number of fatal injuries in low-voltage installations. At present, residual current devices are applied in all low-voltage installations and



Fig. 1 Residual current device by Felten&Guillaume for industrial applications, Germany, 1956



Fig. 2 Residual current device with delayed tripping, sensitivity of 35 mA; manufactured by Felten&Guillaume, Austria, 1958

following areas of applications are defined depending on the purpose of their use:

1. additional protection by RCD with sensitivity $I_{\Delta n} \leq 30 \text{ mA}$;
2. protection by automatic disconnection in case of failure; sensitivity depends on the condition in the place of installation;
3. protection against fire caused by leaking currents by RCD with $I_{\Delta n} \leq 300 \text{ mA}$.

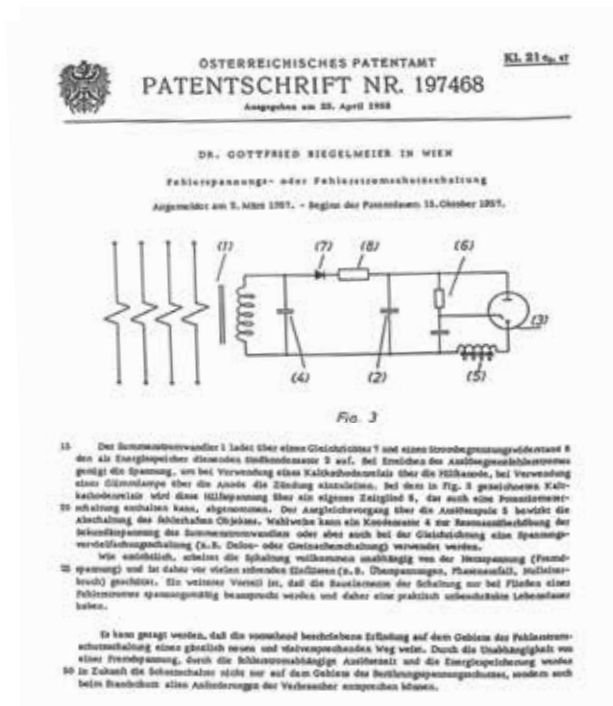

Fig. 3 Patent for residual current device with capacitor as an accumulator, Dr. Gottfried Biegelmeier, Austria, 1957

2. Effects of electric current on the human body

In case of human contact with a live conductive part, current will start to pass through the body and if its value exceeds a certain limit, a fatal injury may occur. Electric current has a different effect on every person - depending on contact potential, current value, frequency and, naturally, also on duration of exposure. To a great extent, it also depends on the conditions of external influences such as humidity, moisture, etc. Results of research are summarized in report IEC/TS 60479-1: Effects of current on human beings and livestock- Part 1: General aspects [1]. This standard describes the effect of alternating current with frequency up to 100 Hz and the effect of direct current. Beside Part 1, there also other parts dedicated to various current paths, high frequencies etc. The basic standards for determining the conditions of safety are IEC 61140 ed. 2: Protection against electric shock - Common aspects for installation and equipment [16] and the following IEC 60364-4-41 ed.2 (2007): Protection against electric shock [19]. This directly involves also the definition of properties of residual current devices.

Heart function is controlled by electric impulses and any external impact may cause it to stop or cause uncontrolled oscillation of heart chambers called fibrillation. The most dangerous situation occurs in the event of current passing from left arm to legs, when the main part of the body current impacts the heart. This has been well-known for a long time but there was no evidence of the effects of current on human beings. To confirm the relevance of use of sensitive residual current devices, Professor Gottfried Biegelmeier from Austria underwent a number of experiments on his own body in the 1980s. He is globally known as one of the European pioneers in the research of effects of electric current on human beings and was also the author of several patents in the area of residual current device design. He gradually exposed himself to the effects of alternating current at the voltage of 25 to 220 V. The electrocardiograph indicated potential irregularities of electric heart impulses. A physician assisted these experiments and a defibrillator was ready in case of heart fibrillation. Recording devices registered voltage and current paths and the actual experiment was also caught on film.

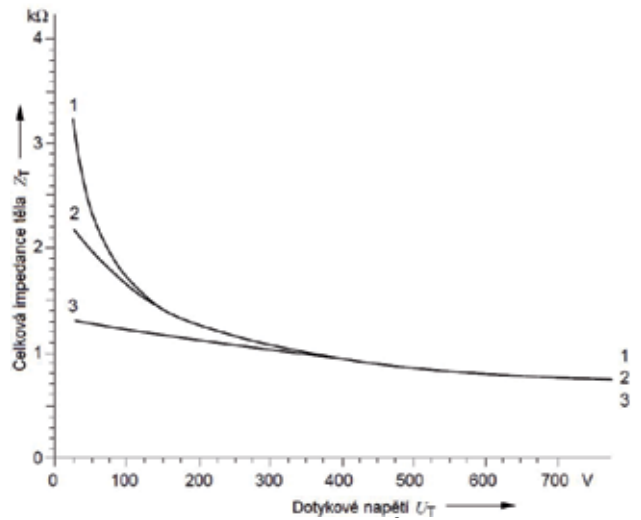

Fig. 4 Total impedance Z_T for current path between both hands with a large contact surface area for alternate contact $U_T = 25$ V up to 700 V, 50/60 Hz in varying conditions [1]

The records clearly show that at a voltage of 220 V, the body current is so strong that it causes strong muscular contractions. Measurement took place with dry and wet hands using cylindrical electrodes, while current was passing between the two hands.

In the course of further measurements, current flowed from left hand into both legs. Copper sheet shoe insoles were used as electrodes, see Figure 5. Using electrocardiograph, it could be identified, in which cardiac action phase the effect of current shows major effect.

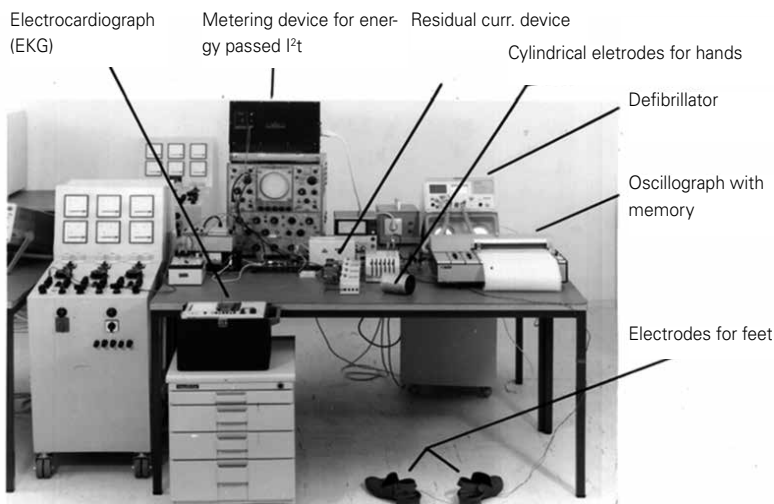

Fig. 5 Photo from Professor Biegelmeier's experiments on the effects of current on his own body [3, 4]

Current surges often extended into the vulnerable stage of heart (vulnerable phase). The Figure 6 shows this vulnerable phase as the T wave, which takes approximately 200 ms. There is a high risk of triggering ventricular fibrillation. Effects are seen in the ECG and blood pressure.

The results of the research are:

- ▶ currents from 10 to 30 mA are not fatal but their prolonged presence causes muscular spasms, breath problems etc.
- ▶ **currents above 30 mA may be fatal unless the person is quickly separated from the source**
- ▶ currents up to 500 mA will cause death if they pass for longer than 0.5 s;
- ▶ currents above 500 mA are usually fatal even in short exposure times.

An assessment of the influence of DC current on humans is based on descriptions of the currents effects for each of zone (DC-1 , DC -2 , etc.) which correspond to the effects of alternating currents (see Figure 7), wherein the values of DC current body is approximately four times higher, than with AC current.

Executed experiments confirmed the presumption body impedance is shared around to the same extent by arms and legs. Professor Biegelmeier withstood without any health consequences almost 500 current surges. This unambiguously confirmed that sensitive residual current devices are able to provide protection from fatal injuries even in direct contact with live parts. This was also one of the decisive moments for an ultimate recognition of additional protection by sensitive residual current devices in case of direct contact of persons with a live part.

Figure 7 shows the conventional zones of alternating currents (15-100 Hz); the current path from the left hand to feet depending on the contact time and the corresponding limit trip times of RCDs with a sensitivity of 30 mA.

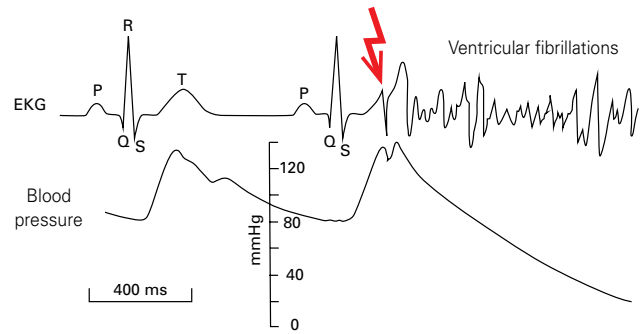

Fig. 6 Record of ECG (electrocardiogram) of human heart after exposure to electric current

Marking AC1 to AC4 expresses zones of action of alternating current (AC - Alternating Current). Curves a, b and c express the limits for various effects of current:

- **curve a is the threshold of perception** (current of 0.5 mA causes tingling);
- **curve b is the drop threshold**, when an exposed person can no longer drop the object under current;
- **curve c1 is the so-called safety threshold**. There may be pathophysiological effects such as cardiac arrest, breath arrest, burns or other damage on cellular level. The likelihood of chamber fibrillations rises with current intensity and duration.

Note:

It might appear that the higher the sensitivity the better. Highly sensitive RCD are very likely to frequent tripping due to leaking currents and their contribution to safety is not high. In case of a human being's contact with a live part, current will pass through the body, being only limited by the body's impedance, and the residual current device will only react after certain time (10 - 30 milliseconds). At the moment of contact with a live part, the person will be hit by a full electric surge and it makes virtually no difference if a residual current device with a sensitivity of 10 or 30 mA is applied.

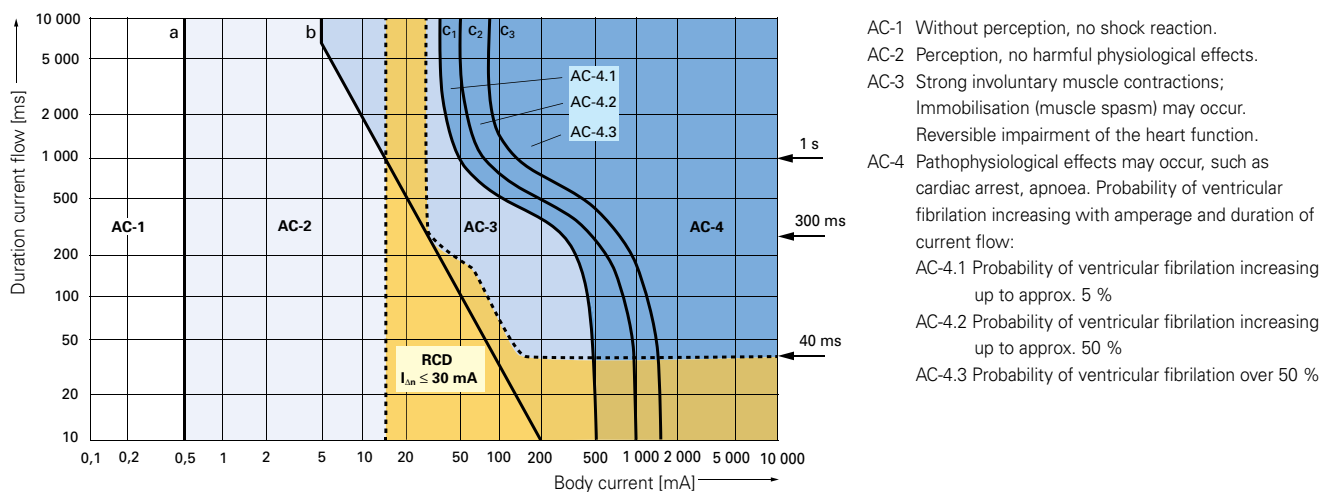
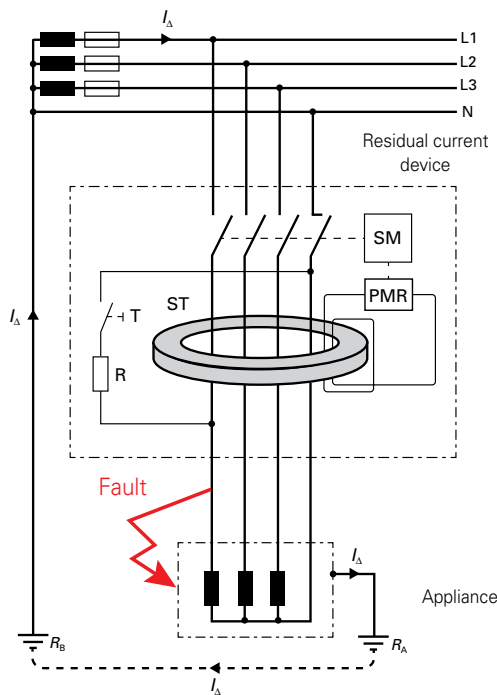

Fig. 7 Agreed-on areas of time/current of alternating current effects (15 - 100 Hz) on persons for current path corresponding to the passage from left arm into feet and comparison with limits of tripping times of residual current device $I_{An} = 30 \text{ mA}$ [1], [13]

3. Types and characteristics of residual current devices (RCDs)

3.1. Functional principle of RCDs

Every residual current device (RCD) has three basic components - **summation current transformer, trip relay and switching mechanism**. The function of the various parts is to detect and to evaluate the residual current and to interrupt the power supply if the residual current exceeds a certain value. For correct function of an RCD, **all live conductors of protected circuit**, or at least as many conductors as necessary for correct appliance function, **must pass through the summation transformer**.



- SM switching mechanism
- PMR permanent magnet relay
- ST summation current transformer
- T test button
- R resistor
- I_{Δ} residual current
- R_A appliance earthing resistance
- R_B power supply earthing resistance

TT network is used for description here, but the same applies analogously for other network types.

Fig. 8 Connection and activity of RCD

An RCD works on the principle of **comparing currents in live conductors** passing through its summation current transformer. In normal conditions (no phase-to-ground fault), the sum total or instantaneous current values equals to zero. Magnetic flow from various working conductors are induced inside the core of the summation current transformer and the sum total of their instantaneous values equals to zero (vectorial sum). Only once earth current flows, a certain part of the current starts to flow outside the live conductors, which creates an imbalance condition. This causes excitation of a corresponding magnetic flow inside the core of the summation current transformer and the output winding generates current that will activate the trip relay and gives impulse to tripping the contacts of the RCD.

Summation current transformer is mostly designed as a ring-shaped transformer. Permalloy is used as magnetic material; newer types may use special magnetic materials with nanocrystalline structure. The core of a voltage-independent RCD is a **trip relay with permanent magnet (PMR)**, see Figure 9. In idle state, the relay armature is constantly held. Once current is conducted into the excitation coil, the attraction force of gravitation of the permanent magnet is weakened and the spring force will swing away the relay armature. Owing to its simplicity and proven reliability, this type of polarized relay is applied most frequently.

a) basic structural parts

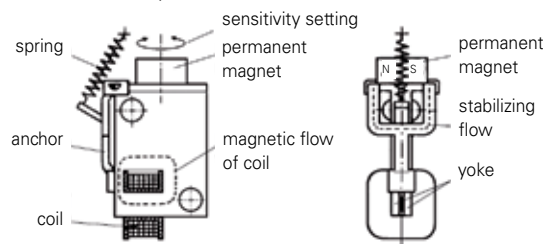

b) view to relay with cover removed

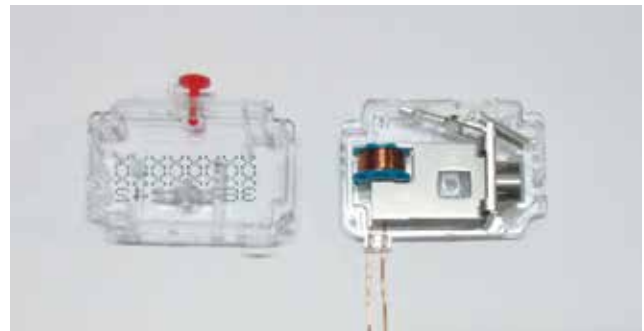
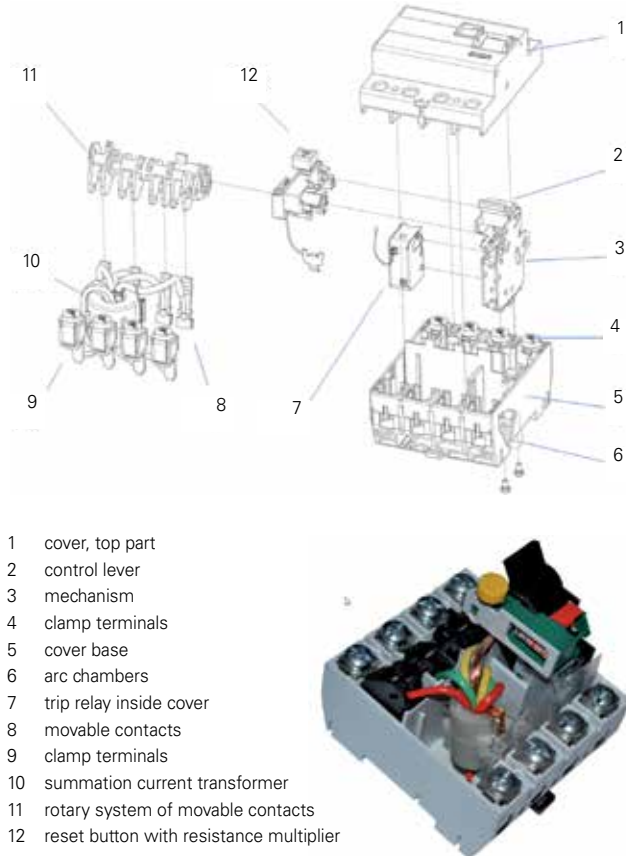

Fig. 9 Trip relay with permanent magnet (PMR)

The **switching mechanism** of the RCD must be sensitive and at the same time provide sufficient force on the contacts. Reliable function must be ensured in all assembly positions. Every load current path must be capable of conducting nominal current for the entire lifespan. The distance between tripped contacts must provide safe electric insulation and contacts must be protected from surge currents and short-circuits with presumed short-circuit current. It is further required that for multi-polar types, contacts for neutral conductor N must close before and open after contacts for line conductor L. The reason is limitation of unwanted surge voltage in the phases.

All RCDs must be equipped with a **testing device** consisting of a test button T (Test) and a resistance R, dependent on the operating voltage. The test button must be accessible by the user. By pushing it, residual current will be simulated using test resistor R, causing current to flow outside the summation transformer.

Sensitive RCDs provide protection against fatal injury in the event that a residual current occurs, i.e. if fault current flows outside the RCD. However, based on their functional principle, they are unable to react to such a situation where the fault current flows only between two live conductors, which will occur in the event of two-pole contact by a person or in case of short-circuit between working conductors.



- 1 cover, top part
- 2 control lever
- 3 mechanism
- 4 clamp terminals
- 5 cover base
- 6 arc chambers
- 7 trip relay inside cover
- 8 movable contacts
- 9 clamp terminals
- 10 summation current transformer
- 11 rotary system of movable contacts
- 12 reset button with resistance multiplier

Fig. 10 RCD set - 4-pole version (RCCB)

3.2 Parameters of RCDs

Parameters of RCDs are defined in product standards [12 up to 17].

- **Rated residual operating current $I_{\Delta n}$** : value of residual current specified by manufacturer, when the residual circuit breaker must, under specified conditions, trip. This value is specified on the circuit breaker with the related operating characteristics. It is the main parameter of the residual current device and the conditions of protection against hazardous contact are related to it.
- **Residual current I_{Δ} (differential current)**: effective value of resulting vector of instantaneous current values flowing through the main circuit of the RCD. I_{Δ} is any current value lower, equal to or higher than $I_{\Delta n}$.
- **Residual non-tripping current $I_{\Delta no}$** : value of residual current, at which (including lower values), the circuit breaker, under specified conditions, will not trip. Defined by the threshold of $0.5 I_{\Delta n}$. Values of residual non-operating and operating current are pre-set at manufacturing plant to $0,75 I_{\Delta n}$.
- **Limit non-operation time $t_{\Delta a}$ (time delay)**: maximum time, for which the circuit breaker may be exposed to a higher value of residual current than the nominal residual current value $I_{\Delta n}$ without actually activating it. This value characterizes RCDs with delay (types G, S and others, whereas for type G, the limit non-operation time is 10 ms, and for type S 40 ms). During the non-operation time, the residual current device does not respond to residual currents.

The main parameter of a residual current device is rated residual operating current $I_{\Delta n}$. Normalized values are 10, 30, 100, 300, 500 mA and 1 A. If the residual current achieves the value of 100 % $I_{\Delta n}$ or more, the RCD must trip. If the residual current does not reach 50 % $I_{\Delta n}$ it must not trip. Thus, the RCD can trip from 50 to 100 % $I_{\Delta n}$. This practically means that, given a sensitivity of RCD of 30 mA, tripping may occur as early as once the earth-leakage current of 15 mA is achieved, which causes problems in installations with higher leaking currents. This increases their applicability in circuits with higher leaking currents.

3.3 Dependence on supply voltage

Based on their dependence on supply voltage, RCDs can be subdivided as follows:

- a) voltage independent (VI) - functionally independent of supply voltage (previously called FI);
- b) voltage dependent (VD) - functionally dependent on supply voltage (previously called DI);
- c) dependent on auxiliary supply - allowed only in installations with qualified operating personnel.

a) RCDs independent of supply voltage

RCDs independent of supply voltage need no auxiliary energy for operation and only make use of residual current obtained from the output winding of the summation current transformer. Its protective function is only dependent on the residual current. The only dependence on supply voltage concerns the testing device that generates the necessary residual current only within a specific voltage range.

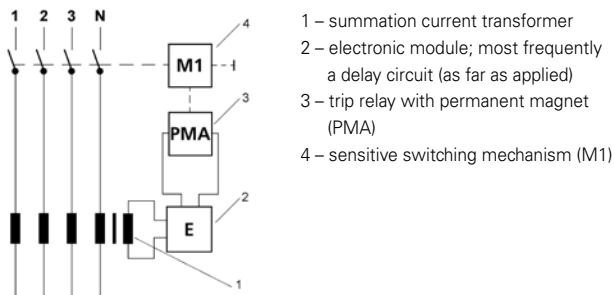

Fig. 11 Wiring diagram of RCD, functionally dependent on supply voltage (VI)

The electric circuit on secondary side of transformer is designed to operate at very low tripping input power (approx. 50 to 120 μ VA). Obviously, a very sensitive trip relay and a precise mechanism are essential for the reliability of the entire device. This is also why regular functional checks using the test button are so important, so that the user has constant indication over the function of the entire RCD.

b) RCDs functionally dependent on supply voltage

In residual current devices dependent on supply voltage, the voltage from output winding of summation current transformer is amplified by means of an electronic amplifier, which subsequently activates a robust trip relay. The electronic amplifier is constantly connected to the supply network and provides sufficient output for the trip relay (approx. 0.1 to 1 W). This type is more resistant to overload by direct pulsating current. Voltage-dependent circuit breakers have reliability fully comparable with voltage-independent types, mainly due to simple construction of the switching mechanism and to the robust trip relay.

RCDs functionally dependent on supply voltage may be designed either as non-tripping or as tripping breakers in case of supply voltage failure. The first type is applied in fixed installations that will stay closed in case of power supply failure. The types tripping in case of power supply failure are mainly applied for protecting circuits of working machines because after re-energization, such machines will not resume operation undesirably.

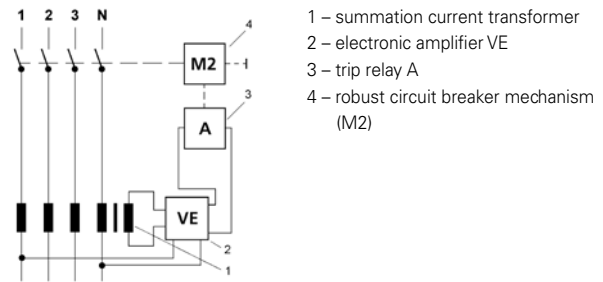

Fig. 12 Wiring diagram of RCD, functionally dependent on supply voltage (VD)

Applied electronic circuits must meet EMC conditions and be sufficiently resistant to pulse surge voltages in the supply network. As with all electronic devices, in new installations, it is mandatory to apply surge voltage protectors, providing sufficient protection.

Note:

The development of RCDs in Europe took the path of voltage-independent types, while America and other countries focused on voltage-dependent types from the very beginning. Long-term research and operation worldwide clearly proved that both voltage-dependent and independent designs nowadays provide completely comparable protection. The international standard IEC 60364 for electric installations therefore considers both types equivalent. Despite this, some manufacturers and standardization committees keep insisting on limiting the use of voltage-dependent types claiming their hazardousness and risk of failure. An argument used against voltage-dependent types is for instance the risk of interrupting the neutral wire (N), in which case the electronic circuits will not work. However, if supply is interrupted, all single-phase appliance will immediately stop to work, so the failure becomes instantly evident and it is in operator's interest that the failure be repaired as quickly as possible. Many studies have been developed on this topic, whose result showed that the risk of interruption of neutral wire exists, but in advanced European networks, its likelihood is demonstrably low (rate of failure around 30 ppm). The risk of electric shock is at the same time determined by the likelihood of supply failure with contemporary fault and contemporary contact of person to a live part, so that the resulting likelihood of these combinations in one moment is very low. Fundamental safety standards also define that an RCD must not be the only protective measure (see Figure 51 three-stage protection concept). An RCD never works in isolation but always as part of an entire installation, wherefore it is never solely liable for the safety of the entire installation. Even a TN network by itself provides a much higher level of safety than a TT network. The conclusion is that, with respect to all elements of an installation, determining its safety, it is unimportant if voltage-dependent or voltage-independent types of RCD is used. Additionally, voltage-dependent types nowadays provide a number of additional functions, which are not feasible with classic electro-mechanical types. An example are with the long-term used B types in all possible variants.

Power Direction Classification of RCD Products

To support product selection and ensure compatibility with various system architectures, the following table shows Eaton RCCB and RCBO devices according to their suitability for bidirectional or unidirectional power supply. This classification helps

clarifying voltage dependency and highlights application relevance in different scenarios from conventional installations, renewable energy sources to energy storage systems.

		Power supply	
		Bidirectional	Unidirectional
RCCB	xEffect FRCdM Type B, B+, Bfq		√
	xEffect FRCdM Type A and F	√	
	xEffect FRCmM-125 Type B, B+, Bfq	√	
	xEffect FRCmM Type F	√	
	xEffect FRCmM Type AC and A	√	
	xEffect FRCmM-125 Type A, AC	√	
	xEffect FRCmM-NA	√	
	xPole mRCM	√	
	xPole PFIM Type B		√
	xPole PFIM Type F	√	
	xPole PFIM Type AC and A	√	
	xPole PFGCM	√	
	xPole PFGM	√	
	xPole EAM (xPole UK)	√	
	xPole PF6/7	√	
	xPole Home HNC	√	
	xClear CLC	√	
	xEffect FBSmV add-on unit	√	
xEffect FBHmV add-on unit	√		
RCBO	AFDD		√
	xEffect FRBdM		√
	xPole dRBM		√
	xPole NdRBM	√	
	xEffect FRBm6/M		√
	xEffect FRBm4, 3+N-pole		√
	xPole NmRB4/6/M- NOR Specific	√	
	xPole eRB6/M		√
	xPole mRB4/6	√	
	xPole mRB64/M4	√	
	xPole P XK- German Specific	√	
	xPole PKN6/M	√	
	xPole PKP62/M2	√	
	xPole PKN4	√	
	xPole PKP42		√
	xPole PFL6/7		√
	xPole Home HNB		√

Tab. 1 Power direction classification of RCD products.

3.4 Testing device (TEST)

Every RCD must be equipped with an accessible and clearly marked test button. Functionality must be tested using this button at regular intervals following manufacturer's recommendations, usually once a month. For new types with enhanced operational reliability, this interval is six months to one year. The test button circuit is wired so as to generate a residual current, which is higher than the rated residual current of the RCD $I_{\Delta n}$. Product standards prescribe that at nominal voltage the magnetic flow induced in summation current transformer must not exceed 2.5-times the flow generated by rated residual current $I_{\Delta n}$. Test device must be still effective at 0.8-times the nominal voltage.

Four-pole RCDs may be applied also in circuits with a lower number of live conductors. At the same time, conductors must be connected into the correct terminals so as to maintain the function of the test circuit. The test device in typical RCDs is designed for mains voltage (400 V) and works also with phase voltage (230 V) without any problems. Recommended connections are specified in the catalogue. With respect to electronic circuit wiring, when necessary, forbidden connections are highlighted. **A universal solution is the connection of all input clamps to all live conductors of the network** and only the required number of conductors can then be connected to output terminals.

a) types PF series, FRCmM, etc.

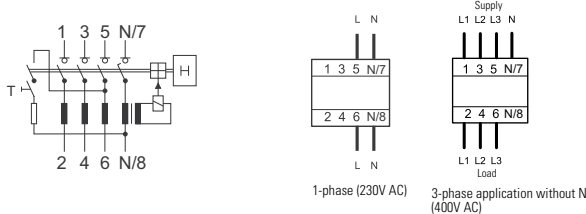

b) type dRCM (digital type)

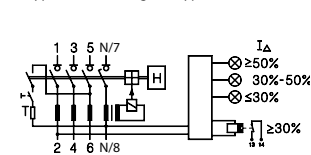

c) type FRCdM (B type)

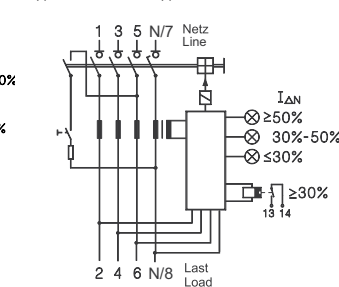

valid for b)

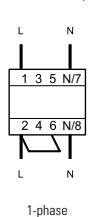

valid for b), c)

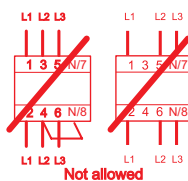
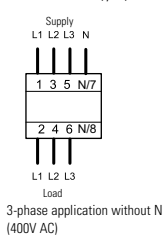

Fig. 13 Examples of internal wiring of testing device (Test) connected between L3 and N

3.5 Resistance to short-circuit and overload

Main parameters concerning resistance to surge currents are:

- **rated switching and tripping ability I_m** : effective value of alternating component of presumed short-circuit current, determined by manufacturer, which the RCD can switch under specified conditions. This parameter relates to short-circuit current in live conductors.
- **rated switching and tripping ability $I_{\Delta m}$** : effective value of alternate component of presumed residual current, determined by manufacturer, which the RCD can switch under specified conditions. This parameter relates to short-circuit current between live and protective conductors.

Tripping ability ($I_m, I_{\Delta m}$) of the actual residual current circuit breaker (RCCB) without safety element is very restricted. For currents up to 40 A, this value amounts to 500 A, for $I_n = 63$ A it is 630 A, for $I_n = 80$ A it equals to 800 A and for $I_n = 100$ A the tripping ability is 1,000 A. Although the contacts are located in arc chambers, tripping times of 10 ms and above (e.g. in selective types, this value is minimally 40 ms) are too long to achieve a high short-circuit resistance of contacts. The fuse may be located anywhere on the input.

Conditional short-circuit resistance (I_c) is the value of short-circuit current with preliminary fuse gG/gL, where no damage will occur to contacts.

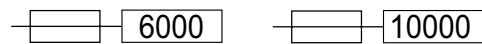

Fig. 14 Symbol for conditional short-circuit resistance of 10 kA with upstream (back-up) fuse with prescribed value (e.g. 63 A gG/gL)

RCCB (I_n)	Short-circuit protection (I_c)
16 A	63 A gG/gL
25 A	63 A gG/gL
40 A	63 A gG/gL
63 A	63 A gG/gL
80 A	80 A gG/gL
100 A	100 A gG/gL

Tab. 2 Maximum fuse value for short-circuit protection

Rated current of contacts

RCDs are intended to protect users where overloading of contacts is not permissible in order to prevent them from adhering or welding together by surge currents. Protection of contacts in RCDs with overload protection (RCBO) is provided in all cases. Fuses or breakers must be installed before residual current circuit breakers without overload protection (RCCB). Their rated current is usually chosen so as to make it equal to the rated current of RCD contacts. At first sight, it may appear that it is all right, but it is not true. The problem exists due to different definitions of rated current of circuit breaker contacts and all other switching devices (switches, contactors, ...) and rated current of breaking devices (breakers, fuses). Rated current of contacts defines permanent loading ability of contacts.

However, a different definition applies to circuit breakers. Current level, when a breaking device does not trip within agreed-upon time (typically 1 hour), is called conventional non-tripping current I_{nt} and current that is supposed to trip is called conventional tripping current I_t . For instance, for miniature circuit breakers, $I_{nt} = 1,13 \times I_n$ and $I_t = 1,45 \times I_n$ (see Fig. 15). But this means that contacts may be overloaded for long periods without the circuit breaker tripping. Therefore, the rated current of fuse or breaker should be one level lower than the rated current of the RCD. This must be taken into consideration in all installations with high simultaneity. Concrete values are specified in catalogue documentation and guaranteed by manufacturer.

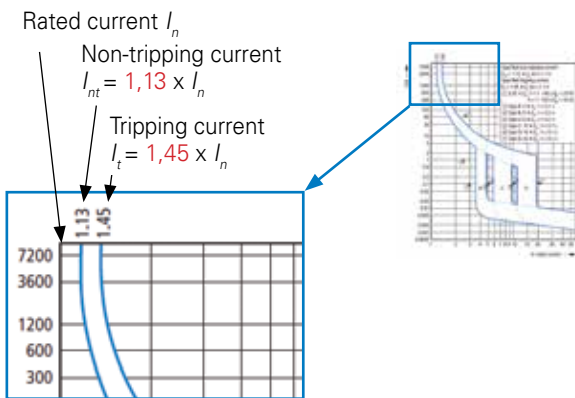
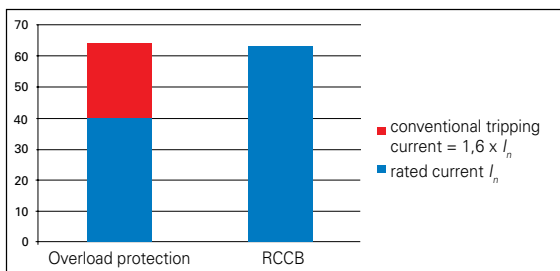

Fig. 15 Comparison of rated currents of RCD and MCB (miniature circuit breaker)



Example:

- RCCB with 63 A
- Overload protection - fuse 40 A gG/gL has non tripping current limit (up to one hour) = $1,6 \times 40 = 64$ A

Fig. 16 Relation between rated current of fuses and contacts of RCCBs

Protection of RCCB against contact overloading

Correctly executed protection of contacts from surge currents means that constantly passing current will not exceed the value of their rated current, for which they are designed.

RCCB	Overload protection	
I_n	xPole series - for residential and commercial installations	xEffect series for industry
16 A	10 A gG/gL	16 A gG/gL
25 A	16 A gG/gL	25 A gG/gL
40 A	25 A gG/gL	40 A gG/gL
63 A	40 A gG/gL	63 A gG/gL
80 A	50 A gG/gL	80 A gG/gL
100 A	63 A gG/gL	80 A gG/gL

Tab. 3 Protection of RCCB against contact overloading

3.6 Selectivity of RCDs

In installations, where RCDs are installed in series, their selective tripping is required in order to disconnect only that part of installation, where the fault occurred. Selectivity between devices connected in series may be either full or partial.

Full selectivity between RCDs is guaranteed when both of the following conditions are fulfilled:

1. RCD on supply side is type S
2. RCD on load side has lower rated residual current value than RCD on supply side

Rule for selective shifting:

$$I_{\Delta n1 S} \geq 3 \cdot I_{\Delta n2}$$

whereas:

$I_{\Delta n1 S}$... selective RCD (type S),

$I_{\Delta n2}$... RCD for general use (i.e. without delay or type with inactivity period of 10 ms - type G and/or its equivalents).

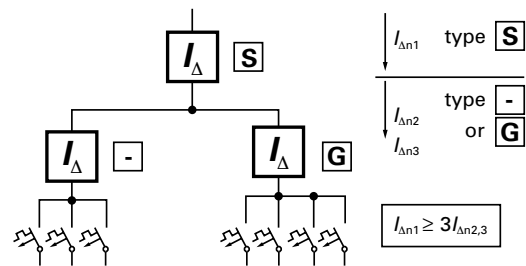

G and S type - see chapter 3.7

Fig. 17 Selective grading of RCDs on two levels

Conditions of full selectivity are specified on Figure 17, based on Table 4 with marginal tripping times. If selective grading of three levels of RCDs are required in industrial installations with qualified operating personnel, RCDs with adjustable parameters can be applied (see CBR, MRCD).

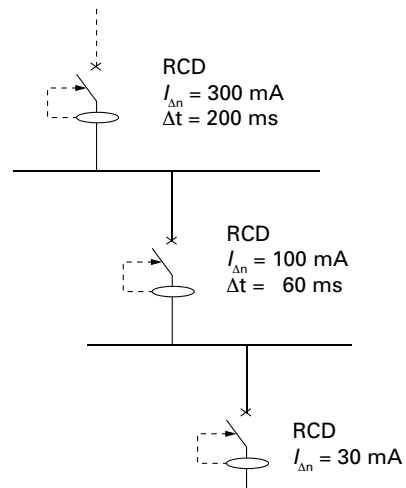
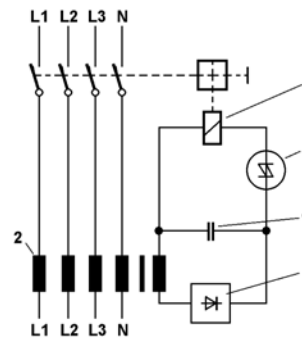

Fig. 18 Selective grading of RCDs on three levels

3.7 Time delay - tripping characteristics □, G, S

From the point of view of the reaction to abruptly generated residual current, RCDs are subdivided into non-delayed and delayed tripping types (with specified non-operation time). Types with delayed tripping are equipped with a delay circuit, the principle of its function is specified on Figure 19. An important component is a capacitor, being charged from secondary winding voltage of summation current transformer. Short impulses of residual current will not provide sufficient capacitor charging. Only longer presence of residual current will result in the rise of its voltage. In the event of excess of working voltage of the monostable element, the capacitor's energy will be discharged into the trip relay's winding. RCDs, type G, are designed for a non-operation time of at least 10 ms, for type S, this period is 40 ms. This is how high resistance to unwanted tripping is achieved. Another benefit is pulse tripping of the relay with sufficient reserve and thus with high tripping security.

First types with delayed tripping were introduced into serial production already in 1958 by company Felten&Guilleaume (Eaton). This principle is used in all modern RCD designed to high resistance against unwanted tripping.



- 1 - differential relay
- 2 - summation voltage transformer
- 3 - monostable element
- 4 - capacitor
- 5 - rectifier

Fig. 19 Functional principle of delaying circuit with capacitor (type G, S)

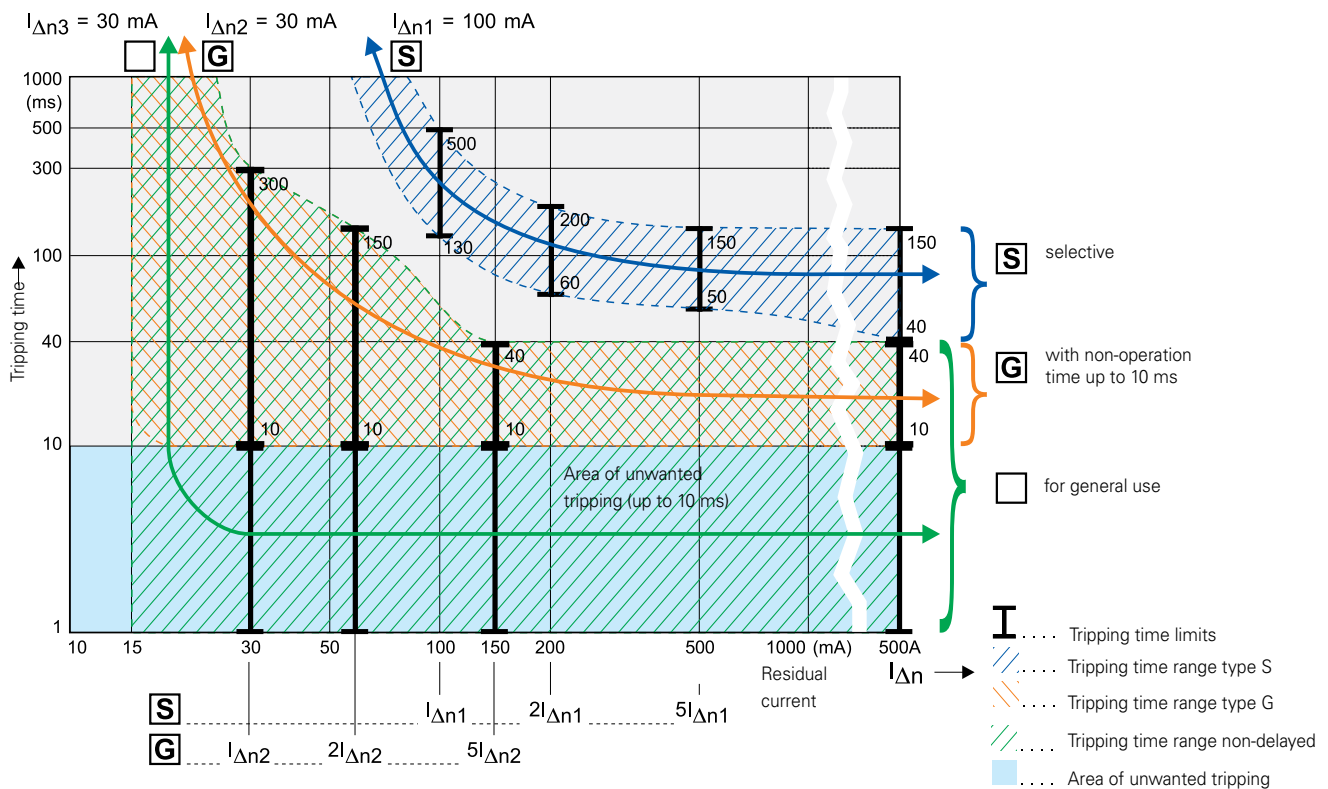

Fig. 20 Limits of tripping times

RCD type		Tripping times [ms]			
		$I_{\Delta} = I_{\Delta n}$	$I_{\Delta} = 2 I_{\Delta n}$	$I_{\Delta} = 5 I_{\Delta n}$	$I_{\Delta} = 500 A$
□	no delay – for general use	≤ 300	≤ 150	≤ 40	≤ 40
G	delayed with non-operation time min. 10 ms	10 - 300	10 - 150	10 - 40	10 - 40
S	selective – with non-operation time min. 40 ms	130 - 500	60 - 200	50 - 150	40 - 150

Tab. 4 Limits of tripping times of RCDs in tests by alternating residual current

- RCD for general use, non-delayed**
 - Resistant to peak currents in working conductors up to 250 A (8/20 μ s).
 - Also reacts to short current surges.

- G RCD with short-term delay, with non-operation time of at least 10 ms**
 - Increased resistance to peak currents to 3 kA (8/20 μ s).
 - Upper limit of tripping time is the same as in RCDs for general use - with sensitivity of 30 mA fulfils the conditions of additional protection.
 - Limitation of unwanted tripping of RCDs by short current surges (coordination with class II and III surge voltage protectors) etc.
 - It is not specified in IEC standards, but resistance to undesirable tripping cannot be guaranteed without it.

- S Selective type, RCD with non-operation time of at least 40 ms**
 - High resistance to peak current up to 5 kA (IEC standards require 3 kA).
 - Meets conditions for tripping time 0.4 or 0.2 s (automatic disconnection).
 - Type S is used as main circuit breaker or in combination with class II (C) surge voltage protectors.
 - Significantly reduces unwanted trippings.

Non-operation time of 10 ms used in type G corresponds to the duration of a half-wave of network frequency. The presumption is that the impact of pulse voltage will cease at the latest on the nearest passage of voltage through zero, see Figure 21. This solution significantly raises the resistance to the impact of short-term residual currents (surge resistant RCDs).

Resistance to surge current with wave shape 8/20 μ s specifies surge current value passing through working conductors, at which the circuit breaker must not trip. Due to a certain asymmetry of particular passes of summation current transformer, however, tripping may occur although residual current has not been generated. The shape of surge current wave 8/20 μ s is depicted on Fig. 22, where 100 % $I_p = 250$ A, 3 kA, 5 kA. This shape of test wave is equal also for tests of class II and III surge voltage protector. For some types of circuit breaker, a reference is made to damped surge current wave 100 kHz, 100/0.5 μ s (Fig. 23), which takes into account the passage of currents in installations when switching lagging load.

Note:
The definition of type G with non-operation time of at least 10 ms was introduced in Austria (nowadays ÖVE E 8601-1) as a solution of problems with unwanted tripping of residual current devices due to surge voltage in storms. (abbr. from German Gewitter = thunderstorm). Several types for special applications were created, for instance type R for X-ray circuits. Type G has the same limits of tripping times as usual circuit breakers, and thus, they are classified by international standards (IEC, EN) into a common group of RCDs for general use. It should be noticed that international standards also use symbol G but with a different meaning. It stands for RCDs for general use (G=General). This may cause misunderstanding.

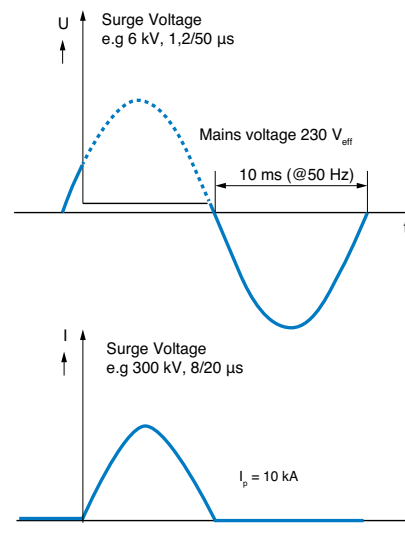

Fig. 21 Resistance to peak currents in type G with non-operation time of at least 10 ms

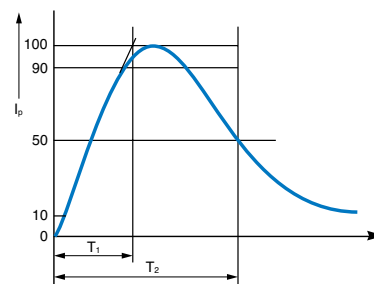

Fig. 22 Shape of surge current wave 8/20 μ s for tests of RCD resistance to unwanted tripping

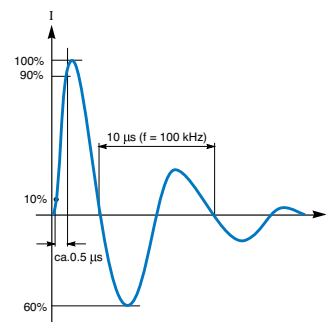

Fig. 23 Shape of standardized damped surge current wave of 100 kHz, 100/0,5 μ s

Special design of RCDs is **type R intended for X-ray devices**. It is an altered version of type G with inactivity period of at least 10 ms. When turning on the x-ray transformer (screening), high peak currents occur, which cause frequent tripping in typical RCDs. The problem of unwanted tripping in circuits with x-rays cannot be underestimated. In the event that a RCD causes disconnection of X-ray or CT (computer tomograph) supply, the examination must usually be put off due to impermissible X-ray exposure of the patient. Executed research shows that the problem of unwanted switching off completely disappeared with the application of R types.

3.8 Sensitivity to various types of residual currents

According to sensitivity to various types of residual currents, the RCDs are typically subdivided to types AC, A and B. With increasing requirements of practice, this scale is gradually extended and types A and B have also several other variants.

Type AC are intended only for alternating residual currents. Pulsating direct current (DC) components of residual current may result in lowered reaction sensitivity or blocking of their tripping function (as per IEC/EN 61008).

Type A for alternating and pulsating direct currents, possibly including the presence of a small value of smooth direct residual current up to 6 mA (as per IEC/EN 61008, see Fig. 25).

Type F are a special variant of type A with altered frequency characteristics, considering sensitivity to high frequencies. This type is only encountered since the introduction of IEC/EN 62423 but the solution is not completely new. The predecessor is **type U**, which was introduced to the market many years ago, when the definition of properties of type F was not yet available.

Type B for all types of residual current, i.e. alternating, pulsating direct and smooth direct residual currents (IEC/ EN 62423). Direct residual currents may occur in industrial and commercial installations (and/or even in residential installations), where frequency inverters, photovoltaic power plants and other equipment with power semiconductor elements are applied.

Type Bfq types is the special Eaton's B type with adapted tripping curve up to 20 kHz for all types of residual current. They are resistant to tripping by leaking currents in circuits with powerful frequency inverters (according to IEC/EN 62423).

Type B+ for all types of residual current with additionally altered tripping characteristics according to the requirements for protection from fire, with tripping residual current up to 420 mA, for frequency up to 20 kHz (requirements for photovoltaic power plants). This version meets the requirements for fire protection according to German standards VDE 0664-440, which is required

by the German Association of Insurance Companies, and comes to our market along with designs originally proposed for Germany.

The fundamental difference between types AC and A consists in the type of material of the summation current transformer core.

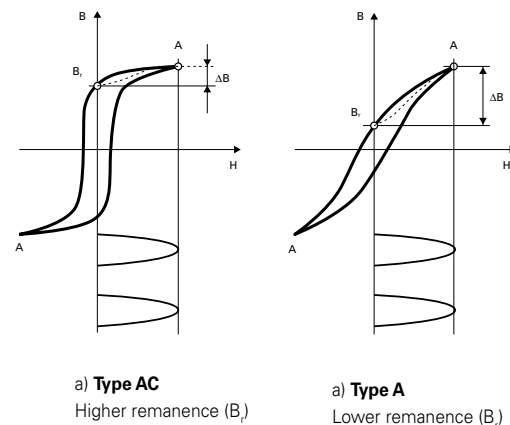

B – magnetic induction [T]
H – magnetomotive force [Am⁻¹]
A – working point for alternate current

Fig. 24 Hysteresis curves of materials of type AC and A summation current transformers

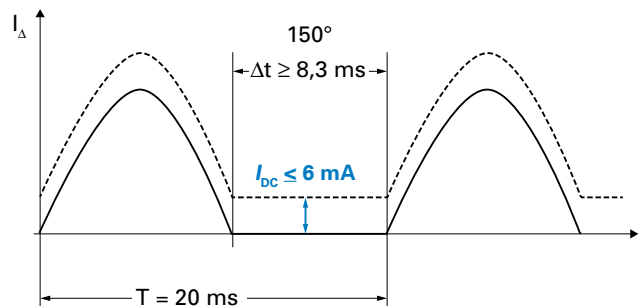

Fig. 25 Definition of pulsating direct component current (6 mA for type A)

RCD type	Symbols	Sensitivity to residual current	Properties	Standards
AC		Alternating	Sinusoidal AC with rated frequency	IEC / EN 61008 IEC / EN 61009
A		Alternating and pulsating direct current	Sinusoidal AC and pulsating DC up to 6 mA	IEC / EN 61008 IEC / EN 61009
F		Alternating and pulsating direct current	Sinusoidal AC and pulsating DC up to 10 mA	IEC / EN 62423
B		Alternating and pulsating direct current and flat direct current	All kinds of current up to 1 kHz	IEC / TR 60755 IEC / EN 62423
Bfq		Alternating and pulsating direct current and flat direct current	The special Eaton's B type with adapted tripping curve up to 20 kHz	IEC / EN 62423
B+		Alternating and pulsating direct current and flat direct current	All kinds of current up to 20 kHz	VDE 0664-440

Tab 5: Types of RCD by sensitivity to types of current

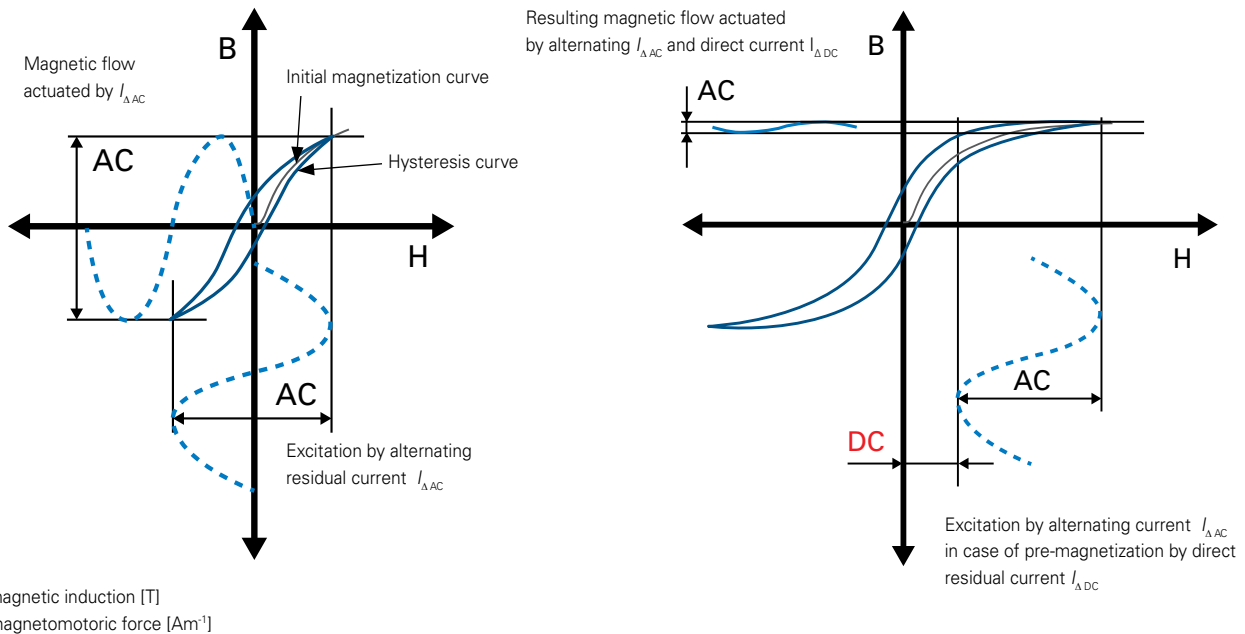

Fig. 26 Impact of direct residual current on core magnetization of summation transformer type A

In case of occurrence of smooth direct current, the magnetic material of summation current transformer and RCD will become saturated and thus insensitive to any further residual currents. RCD will „become blind“ and its protective function is thus overridden. This condition is described on Figure 26. Therefore, the type B of RCD is becoming increasingly popular as they can reliably trip any forms of residual current, within frequency ranges they are designed for (see Tab. 5).

Design solution of type B differs from usual type AC and A RCDs, see Figure 27. Their basic component is a special summation current transformer, actuated by high-

-frequency generator. This creates a precisely defined alternate magnetic flow. A change of the residual current will inflict a change in the intensity of the magnetic field, which will cause a change of the secondary voltage of the summation current transformer. If the change is significant, the electronic evaluation circuit will give an impulse for tripping. Type B RCDs are voltage-dependent in the detection of smooth direct residual currents, and in the detection of alternating and pulsating direct currents are designed as voltage-independent.

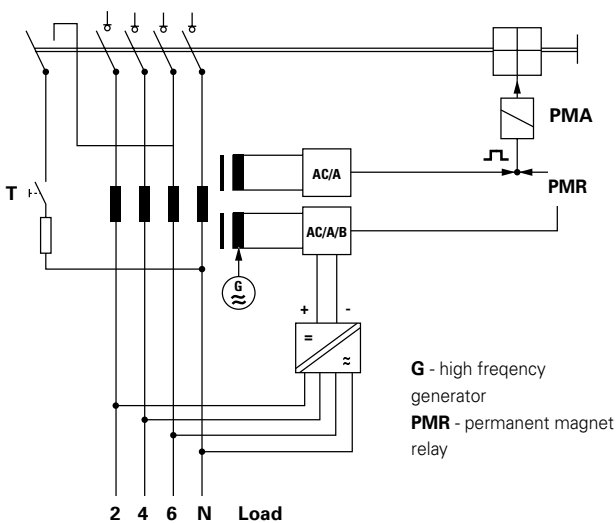

Fig. 27 Wiring principle of type B of RCD

Residual current form	Area of application by type					Tripping current
	AC	A	F	B / B+	kHz	
	•	•	•	•		0.5 to 1.0 $I_{\Delta n}$
		•	•	•		0.35 to 1.4 $I_{\Delta n}$
		•	•	•		Contact angle 90°: 0.25 to 1.4 $I_{\Delta n}$ Contact angle 135°: 0.11 to 1.4 $I_{\Delta n}$
		•	•	•		max. 1.4 $I_{\Delta n}$ + 6 mA DC ¹⁾
			•	•		0.5 to 1.4 $I_{\Delta n}$
				•		0.5 to 2.0 $I_{\Delta n}$

¹⁾ DC component can be: A type max. 6 mA
F type max. 10 mA

Tab. 6 Limits of tripping currents for various types and forms of current, see also Tab. 8

3.9 Operating conditions

Operating conditions differ by type of installation. Normal ambient conditions in household and similar installations (types RCCB and RCBO) are considered as basic operational conditions:

- ambient temperature reaching from -5 °C or -25 °C to +40 °C
- altitude up to 2,000 m (70 to 106 kPa), or even more, depending on manufacturer's conditions
- relative humidity up to 50% at 40 °C; higher humidity is permissible for lower temperatures;
- external magnetic field up to 5-times higher to the earth magnetic field in either direction
- position is specified by manufacturer;
- frequency is specified by manufacturer with a tolerance of $\pm 5\%$;
- degree of pollution 2 (i.e. pollution with non-conductive dust). Higher degree of pollution is expected in industrial installations (up to degree 3 - possible presence of partially conductive dust), higher humidity and potentially higher magnetic field.

3.9.1 Ambient temperature

In indoor installations, the range of ambient temperatures from -5 °C to +40 °C is usually considered sufficient. This operating range is not specified by any marking on the product. Medium temperature in daytime should not exceed +35 °C.

For more demanding applications, however, more resistant types with range from -25 to 40 °C must be applied; these types are then marked as displayed on Fig. 28. All types supplied by Eaton are designed for temperatures starting from -25 °C.



Fig. 28 Identification of residual current devices for ambient temperature from -25 °C

If RCDs are intended to operate at temperatures below -5 °C, a higher value of tripping current threshold is permissible ($1.25 I_{An}$). Also, a requirement for lowering earthing impedances to 80 % is specified, which is taken into account in TT and IT networks.

Temperature	Rated current				
	25 A	40 A	63 A	80 A	100 A
40 °C	25	40	63	80	100
45 °C	22	37	59	76	95
50 °C	19	34	55	72	90
55 °C	16	31	50	68	85
60 °C	–	27	45	64	80

Tab. 7 Impact of ambient temperature on the permanent current (example for FRCmM series)

Loading capacity of the RCD must be taken into account in installations with temperatures above +40 °C. This dependence is specified by manufacturer in catalogue documentation.

3.9.2 Rated voltage

Rated voltage of RCD specifies voltage the circuit breaker is designed for. A protection of single-phase circuits is ensured for the voltage range from 0,85% to 1.1 U_n . For RCDs, functionally dependent on supply voltage, the determining element is resistance in the testing circuit of the test device. If an RCD is applied in circuits with lower than rated voltage, an external test circuit, designed for reduced voltage, must be applied.

At the same time, the testing current should not exceed the value of $2,5 I_{An}$. The majority of RCDs in Europe are designed for the voltage of 230/400 V, a 110 V version is available for the US market. Supply voltage dependent RCDs have their rated voltage determined by the design of electronic circuits.

3.10 Circuits with variable frequency

For type AC and A RCDs, only the rated supply network frequency (typically 50 Hz) is specified. Frequency inverters are used for changing the speed in asynchronous motors, and types with altered frequency characteristics (U, F, Bfq) are designed for these applications. In order to meet the electromagnetic compatibility (EMC) requirements, interference filters are installed and if RCDs are applied for protection, they tend to trip in undesirable situations. The reason for this situation is increasing earth-leakage current of interference filters and stray capacities, which increases with rising frequency (see Fig. 29).

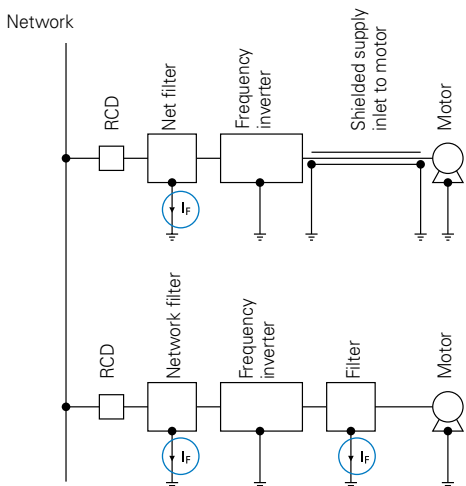

Fig. 29 Occurrence of leaking earth current I_F when using frequency inverters

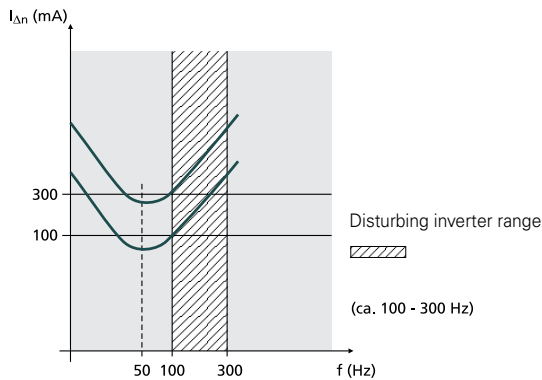

Fig. 30 Frequency characteristics of U type RCD

Frequency [Hz] ¹⁾	Rated non-tripping current ¹⁾	Rated tripping current ^{1) 2)}
100	$0,5 I_{\Delta n}$	$I_{\Delta n}$
1000	$I_{\Delta n}$	$11 I_{\Delta n}$ ³⁾
2000	$1,5 I_{\Delta n}$	$20 I_{\Delta n}$ ³⁾

1) For rated non-tripping and rated tripping current with higher frequencies up to 20 kHz, the manufacturer must specify a limit curve.
 2) This applies to maximum permissible earthing resistance. For other earthing resistances specified by manufacturer, the upper limit of tripping current is reduced accordingly. These values apply at the frequency of 50/60 Hz and at a maximum touch voltage of 50 V.
 3) Coefficient 0.8 is applied, which reflects the limit values of action of alternate current as per IEC/TC 60 479-1 (see Fig. 7, curve c1) and relates to the frequency factor specified in IEC/TC 60479-2.

Note: Technical Report IEC/TC 60479-2 defines limits for frequency up to 1 kHz. Range up to 2 kHz is obtained by extrapolation.

When using any frequency converters, it is necessary to use only these types of RCD, which are designed and tested for this purpose. In case of single-phase circuit, the U type or a newer version F type, in case of three-phase circuits the specified type B must be used.

Beware! Do not confuse type F or type U with properties of for type B!

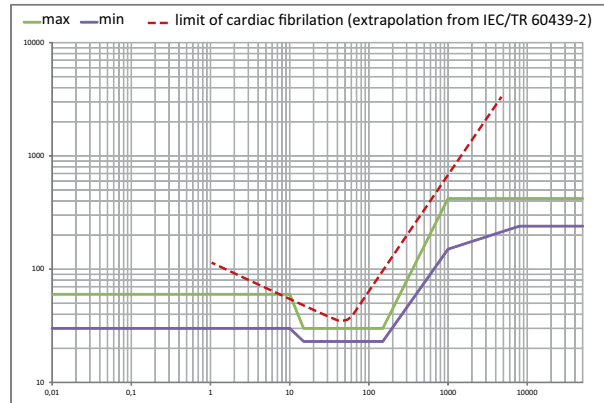

Fig. 31 Example of frequency tripping characteristics of Bfq type RCD with sensitivity of $I_{\Delta n} = 30 \text{ mA}$ [7]

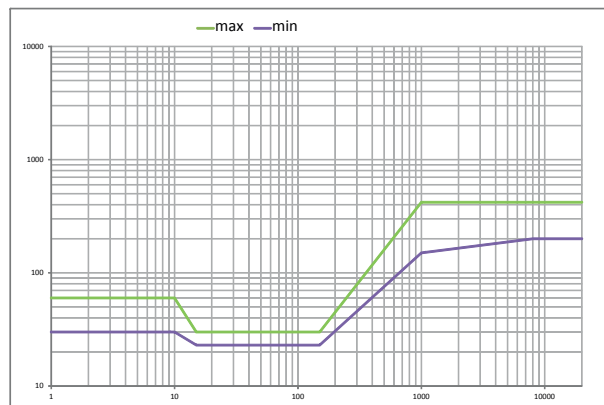

Fig. 32 Frequency characteristics of B+ type RCD with sensitivity of 30 mA [7]

3.11 Marking

Marking must meet the requirements of the relevant product standard. For small devices, at least the following information must be visible after device installation:

- Rated current
- Rated residual operating current
- For selective types: S symbol in a square frame
- Type A, F or B symbol

Information specified on the side or on the rear that may be visible prior to installation:

- Manufacturer (name or brand)
- Type symbol, catalogue or serial number
- Rated voltage
- Rated frequency provided that circuit breaker is designed for a frequency other than 50 Hz
- Position of use - if necessary
- Sign for voltage-dependent types
- Type AC
- Ambient temperature for -25 °C
- Mark of clamp for neutral wire N
- Additional marking (as required by other standards).

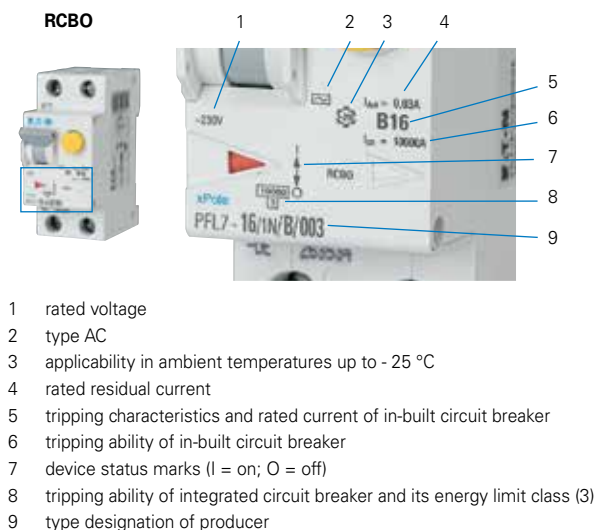
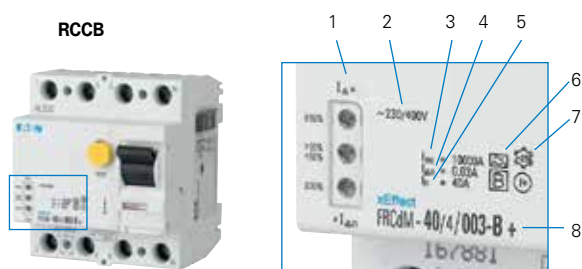

Fig. 33 Example of print on combined residual current devices RCBO



- 1 indication of residual current level
- 2 rated voltage
- 3 rated conditional short circuit breaking capacity
- 4 rated residual operating current
- 5 rated current of RCCB
- 6 sensitivity to pulsating DC currents - type A
- 7 ambient temperature up to -25 °C
- 8 type designation of producer

Fig. 34 Example of print on residual current devices RCCB

	Eaton standard. Suitable for outdoor installation (distribution boxes for outdoor installation and building sites) up to -25° C.
	Conditionally surge-current proof (>250 A, 8/20 μs) for general application.
	Type AC: AC current sensitive RCD
	Type A: AC and pulsating DC current sensitive RCD
	Frequency range up to 20 kHz
	Trip also at frequency composition (10 Hz, 50 Hz, 1000 Hz)
	Type B: All-current sensitive RCD switchgear for applications where DC fault currents may occur. Non-selective, non-delayed. Protection against all kinds of fault currents.
	Type B+: All-current sensitive RCD switchgear for applications where DC fault currents may occur. Non-selective, non-delayed. Protection against all kinds of fault currents. Also meets the requirements of the VDE 0664-400 standard and therefore provides enhanced fire safety.
	RCD of type G (min 10 ms time delay) surge current-proof up to 3 kA. For system components where protection against unwanted tripping is compulsory to avoid personal injury and damage to property (§ 12.1.6 of ÖVE/ÖNORM E 8001-1). Also for systems involving long lines and high line capacity. Some versions are sensitive to pulsating DC. Some versions are available in all-current sensitive design.
	RCD of type S (selective, min 40 ms time delay) surge current-proof up to 5 kA. Mainly used as main switch, as well as in combination with surge arresters. This is the only RCD suitable for series connection with other types if the rated tripping current of the downstream RCD does not exceed one third of the rated tripping current of the device of type S. Some versions are sensitive to pulsating DC. Some versions are available in all-current sensitive design.
	„X-ray-proof“, for avoiding unwanted tripping caused by x-ray devices (type R).
	„Frequency converter-proof“ (type U), for avoiding unwanted tripping caused by frequency converters, speed-controlled drives, etc.

Tab. 9 Usual combinations of symbols used on RCDs

3.12 Design of RCDs

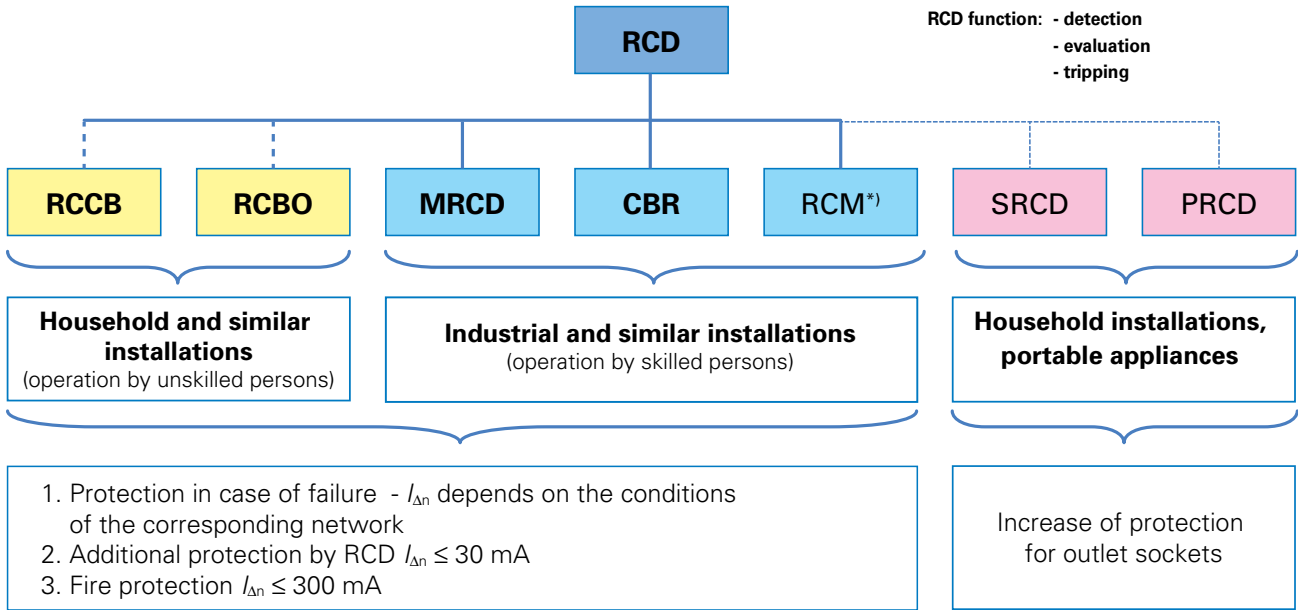

*) RCM detects and signals but not trips; not usable for protective purposes

Shortened name	International name	Subject standards
RCD	Residual Current Device	IEC 60755 General requirements for residual current operated protective devices
RCCB	Residual Current operated Circuit Breakers without integral overcurrent protection for household and similar uses	IEC/EN 62423 ed. 2 Type F and Type B residual current operated circuit-breakers with and without integral overcurrent protection for household and similar uses EN 61008 - Residual current operated circuit-breakers without integral overcurrent protection for household and similar uses (RCCBs) - Part 1: General rules
RCBO	Residual Current operated Circuit Breakers with integral Overcurrent protection for household and similar uses	IEC/EN 61009 - Residual current operated circuit-breakers with integral overcurrent protection for household and similar uses (RCBOs) - Part 1: General rules
RCM	Residual Current Monitors for household and similar uses	IEC/EN 62020 – Residual current monitoring devices for household and similar uses
MRCD	Modular Residual Current Devices	IEC/EN 60947-2, Low-voltage switchgear and controlgear - Part 2 Circuit-breakers, Appendix M
CBR	Current Breaker incorporated with Residual current device	IEC/EN 60947-2, Low-voltage switchgear and controlgear– Part 2 Circuit-breakers, Appendix B
PRCD	Portable Residual Current Device	IEC 61540 – Portable Residual Current Device without integral overcurrent protection for household and similar uses (PRCD)
SRCD	Fixed Socket-outlet Residual Current Device	IEC 62640 - Residual current devices with or without overcurrent protection for socket-outlets for household and similar use

Tab. 10 Abbreviations used for RCDs

Choice with respect to access to installation

In installations, where RCDs are accessible by laymen (BA1), children (BA2) or handicapped persons (BA3), RCDs for household and similar use with fixed set parameters, i.e. RCCB and RCBO (IEC/EN 61008, IEC/ EN 61009, IEC/EN 62423).

In alternate installations, where RCDs are only accessible by instructed persons (BA4) or familiar persons (BA5), also RCDs with adjustable parameters may be used - i.e. CBR and MRCD (IEC/ EN 60947-2).

3.12.1 Residual current devices (RCD)

When talking only about protective function, then the general term RCD – Residual Current Device is used. Only when specific properties or method of installation need to be characterized, a more precise term is used.

Definition specified in product standards:

„Residual current device is a mechanical switching device or association of devices designed to make, carry and break currents under normal service conditions and to cause the opening of the contacts when the residual current attains a given value under specified conditions“.

A residual current device can thus be designed as a compact device on one case or as a set of various independent devices (summation current transformer + protector relay + contactor/circuit breaker), fulfilling the required function only after mutual connection. Product standards applicable to different types of RCD prescribe minimum requirements for design and features. Design of new RCD types offer, besides ensuring safety, extra and additional functions that increase reliability, functionality and offers a higher level of comfort.

3.12.2 Residual current circuit breakers (RCCB)

Residual current circuit breakers are the most frequently used types (RCCB – Residual Current Circuit Breakers).

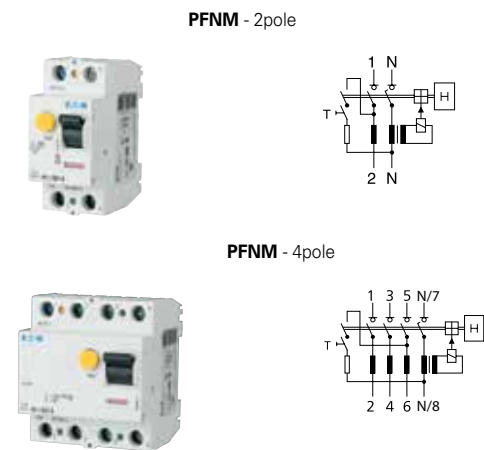

Fig. 35 RCCB without overload protection, a compact device for installation onto DIN rail

Their properties are determined by the fundamental set of standards IEC 61008 - Residual current operated circuit-breakers without integral overload protection for household and similar uses (RCCB). Part 1 defines general rules, part IEC/EN 61008-2-1 defines the requirements for voltage-independent types and part IEC 61008-2-2 is an addition for voltage-dependent types. A condition is the provision of protection against (overload and short-circuit current).

Another possible solution represent RCDs with indirect tripping, where the various components (summation current transformer, breaker relay, switching device) are installed separately and interconnected only at the place of installation. As for RCDs with rated residual currents above 0.3 A, auxiliary winding is used for testing, which is actuated by means of the test button and resistor directly from the network.

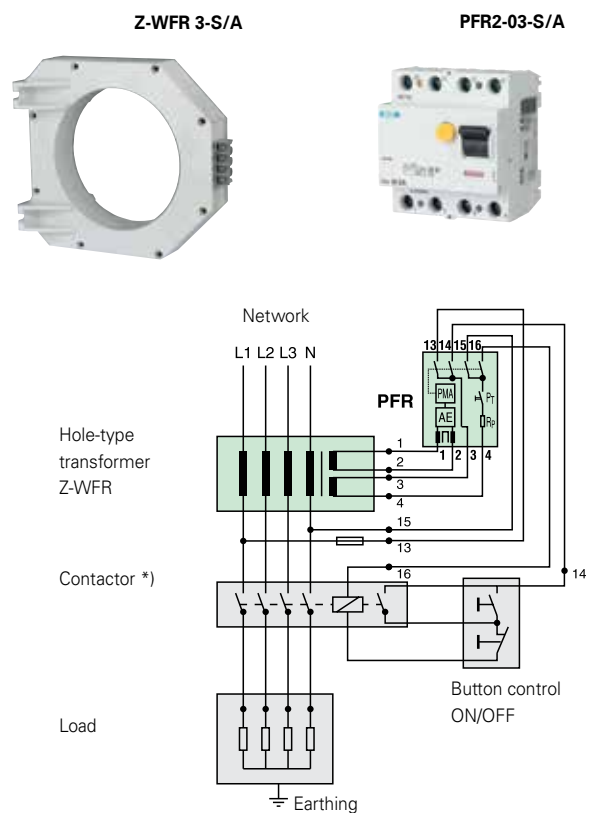

Fig. 36 RCCB with indirect switching with transformer up to 400 A, connection with remote control

Wiring diagram

All conductors necessary for operation L1, L2 and L3 including neutral wire N (if necessary for function) must pass through hole-type transformer:

Insulated conductors must be installed in bundles

Cu bus bar - distance d between Cu bus bars max. 1 cm

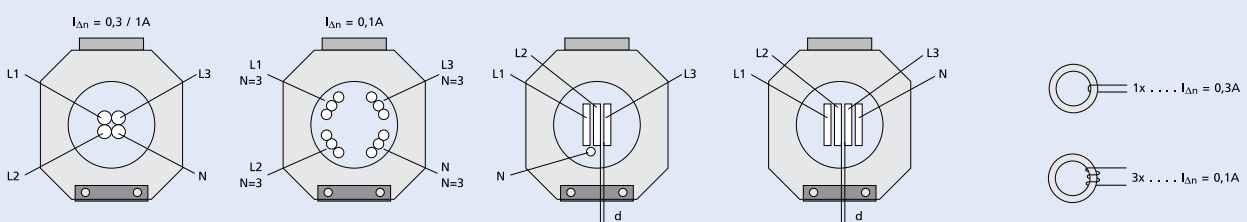

Fig. 37 Symmetric arrangement of live conductors

3.12.3 Residual current circuit breakers with overload protection (RCBO)

Residual current circuit breakers with integrated overload protection are most frequently designed as compact devices, combining the function of an RCD and circuit breaker. The integrated circuit breaker deals with protection of installation and contacts of switching mechanism against overloads. Requirements for design and testing are specified in the set of standards IEC/EN 61009: Residual current circuit-breakers with integral overload protection for household and similar uses (RCBO).

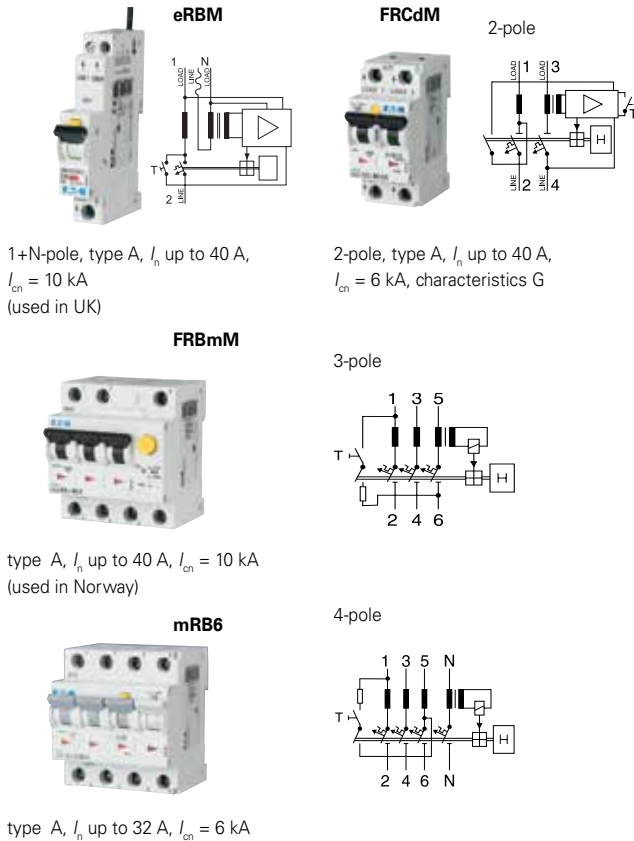

Fig. 38 Residual current devices with integrated overload protection (RCBO)

A separate group of combined RCBO are devices consisting of a circuit breaker and a residual current release. It is easy to combine a circuit breaker with a residual current release, but dismantling is more difficult because changing of the circuit breaker is only possible while mechanically damaging it - for instance by breaking special bolts intended for one single connection of both devices.

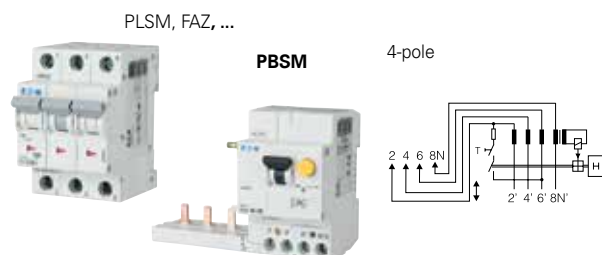

Fig. 39 Residual current release PBSM mounted additionally to the circuit breaker („add on block“)

3.12.4 Circuit breaker with integrated residual current protection (CBR)

For higher rated currents, a combination of a higher performance circuit breaker incorporating residual current protection (CBR) is applied - i.e. devices forming one single device once connected. The conditions of design and properties are specified in standard IEC/EN 60947-2 Circuit Breakers, Appendix B, with detailed requirements for devices with higher residual currents, where standard IEC/EN 61009 cannot be fully applied.

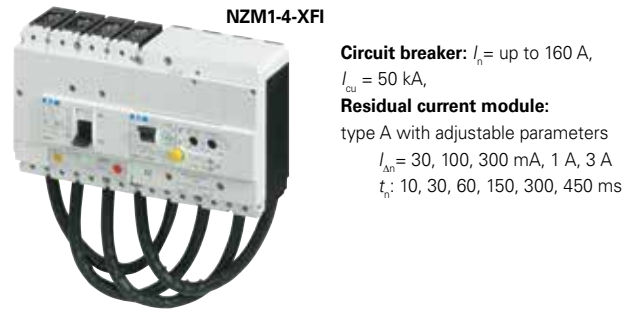

Fig. 40 Circuit breaker with residual current protection (CRB) with multiple setting, type NZM1-XFI30R

Compared to typical RCDs for household use, different requirements are defined for CBRs. One of the differences is the time delay, where preferred values of inactivity can be selected from the following values: 0,06 s – 0,1 s – 0,2 s – 0,3 s – 0,4 s – 0,5 s – 1 s. They are verified at $2 \cdot I_{\Delta n}$ and tripping times must not exceed values specified for type S, specified in Table 4. Marking ‚S‘ can be used for identifying the tripping characteristics whereas the shortest possible non-operation time is extended to 60 ms from the usual 40 ms.

CBR have the possibility of multiple parameters (rated residual current, time delay), thus they can only be used where it is operated by skilled persons. Then it is not allowed to install them in any residential or similar installations.

A separate group of CBRs are air-operated circuit breakers with rated currents up to $I_n = 6300$ A, which can be fitted with triggers for protection against earth connection, with sensitivity ranging from tens to hundreds of amps. They can also be operated with alarm only, without shutdown.



Fig. 41 Circuit breakers with residual current protection for industrial use (CBR)

3.12.5 Modular residual current devices (MRCD)

Modular residual current devices do not have a dedicated contact system. Such a contact system may be a circuit breaker, switch or contactor. The requirements for design and testing are described by standard IEC/EN 60947-2, Appendix M, adopting and extending the conditions specified in Appendix B of the same standard (Circuit breakers with integrated residual current circuit protection - CBR). Such devices can be operated only under supervision of instructed or skilled persons, so they can be mainly encountered in industrial applications.

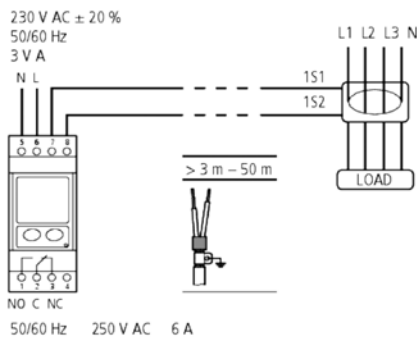

- rated currents of transformers up to 1800 A,
- adjustable sensitivity from 30 mA to 3 A,
- adjustable non-operation time 20 ms to 5 s

Fig. 42 Modular residual current circuit breaker (MRCB)

Figure 43 shows manufacturer's warning about the need to achieve the best possible symmetry of working conductors in summation current transformer. The reason is to maintain the lowest possible inductive coefficient deviations of the various conductors. Any asymmetry will have a negative effect to undesirable tripping by surge short-circuit currents. Current flowing through neutral conductor must not add to the measurement of residual current. Only working conductors of protected circuit, not PE or PEN [24], must pass through summation current transformer (sensor). To enable for instance armoured cables to be passed through, the cable may be passed through along with a PE conductor whereas the protective conductor will subsequently be passed back, see Figure 44. The protective conductor must be isolated and must not be earthed on the first or on the second passage through the sensor.

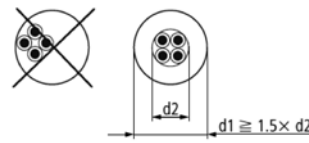

Symmetric cable location reduced unwanted tripping as result of surge currents (see also Fig. 37)



Magnetic shield for demanding applications reduces unwanted tripping; intended for circuits with high surge current ($I > 4 \times I_n$)

Fig. 43 Conditions of correct installation of hole-type transformer for restricting unwanted tripping

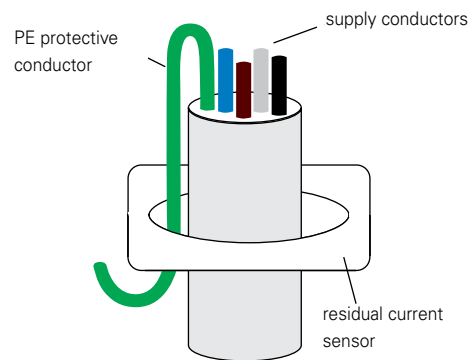
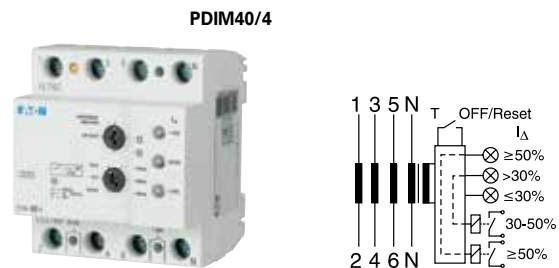

Fig. 44 Connection of protective conductor when cable passes through current transformer [24]

3.12.6 Residual current monitors (RCM)

Residual current monitors (RCM) are devices intended for detecting and assessing residual current. When the pre-set value is exceeded, such unwanted condition is signalled by means of a visual and/or acoustic alarm device. The alarm must persist until the failure is removed. **RCMs are not intended for protection against electric shock.** If an RCM is placed after an RCD, its sensitivity should be set to a value not exceeding a half of the value of $I_{\Delta n}$. The requirements of these types are specified in standard IEC/EN 62020 – Residual current monitors for household and similar uses.

Sensitivity $I_{\Delta n}$ can be set from 30 mA to 1 A with possible selection of non-operation time $t_{\Delta n}$ for types G and S.



Rated current $I_n = 40 \text{ A}, 100 \text{ A}$
 Sensitivity $I_{\Delta n}$: 30, 100, 300, 500, 1000 mA
 Tripping characteristics: undelayed, G, S
 Type A
 Signaling of residual current level: 3x LED
 Remote signaling by incorporated auxiliary switch

Fig. 45 Residual current monitor (RCM)

3.13 Digital RCDs

Digital RCDs combine protective functions with innovative supplementary functions utilizing state-of-the-art digital technology. Thus, they provide maximum possible comfort of status indication and increase resistance to unwanted tripping, because all types are made with non-operating time of at least 10 ms (G, R) or 40 ms (S - selective). Digital technology is applied in types without overload protection (RCCB) as well as in types with overload protection (RCBO). Devices continuously measure the level of residual current and signal either locally by LED indication or remotely by integrated potential-free contacts.

It is designed as a voltage-independent type, which will satisfy the requirements in all countries. Additional residual current value measuring functions are supplied by the network voltage.

Digital RCDs combined with a circuit breaker (RCBO) are available as type A devices.

They are furnished with electronic circuits with highly precise evaluation of instantaneous residual current value. Pushing the test button enables to display the residual current level with an accuracy of 1 mA. The device is further equipped with an automatic functional check of electronic circuits which is activated at each activation and any time during operation by means of service button. The identified condition is indicated by an integrated LED.

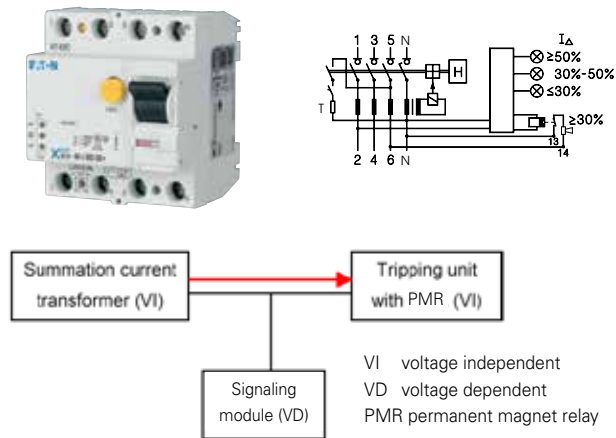

Fig. 46 Four pole B with residual current level signaling (FRBdM series)

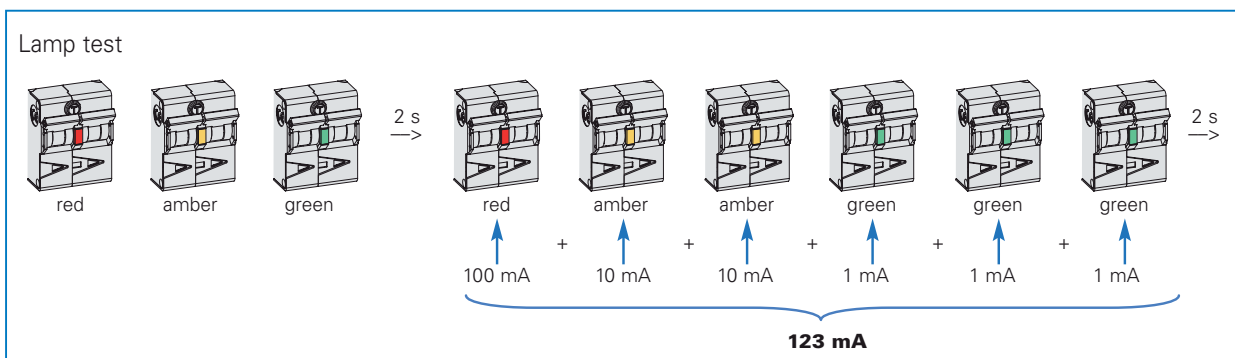
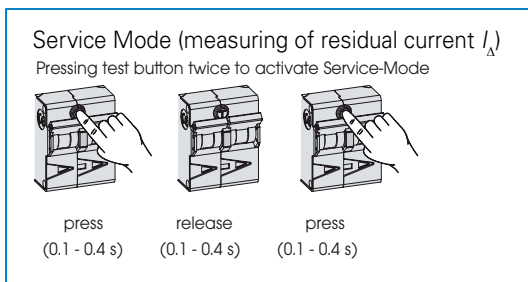

Fig. 49 Digital RCDs with overload protection (RCBO) with local indication of residual current value by LED

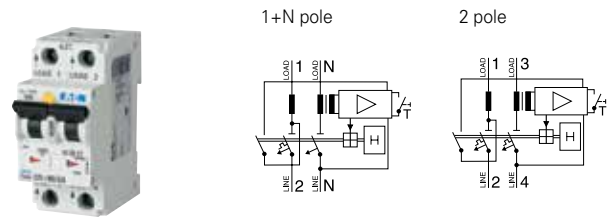
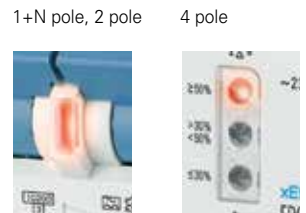

Fig. 47 Digital Combi-switch RCBO with residual current level signaling (FRCdM series)

Red

When the red LED lights up, the leakage current is already higher than 50 percent of the nominal fault current. Therefore the system is in a critical status – the digital RCCB only trips when the fault current continues to increase.



Yellow

The yellow LED shows a residual current in the range of 30 to 50 percent of the nominal fault current. Before the system is shut down, professional countermeasures can be taken.

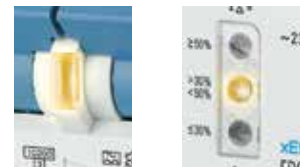

Green

If the current flow in the system to ground is in the range of 0 to 30 percent of the nominal fault current, the green LED indicates the proper status.

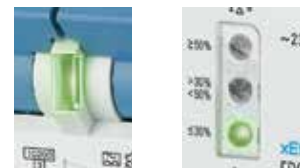

Fig. 48 Indication of residual current level by LED (FRCdM series)

4. Protection against electric shock

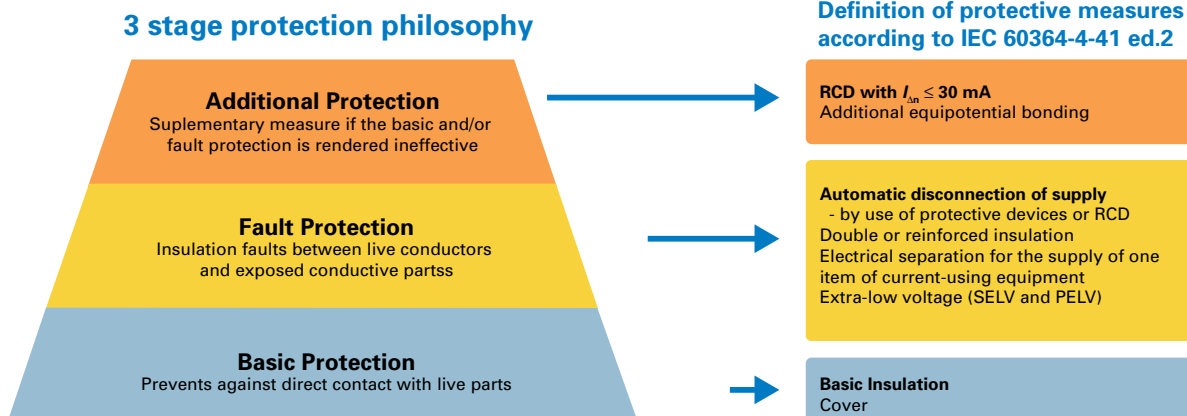
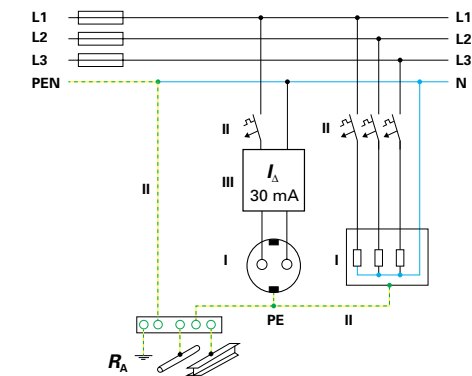

Fig. 50 Three-stage protection concept [2, 13]

Electrical installations consist of various components and safety is dependent on the reliable function every single one of them. The correct function of RCDs is also dependent on the selection of a suitable type and by their correct installation. Prior to commissioning, the safety of the entire installation must be assessed by initial verification and, in the course of its operation, regular verifications must take place. The reliability of RCDs is dependent on their regular testing.



- I - Basic Protection
- II - Fault Protection
- III - Additional Protection

Fig. 51 Three-grade protection in an installation [2, 4]

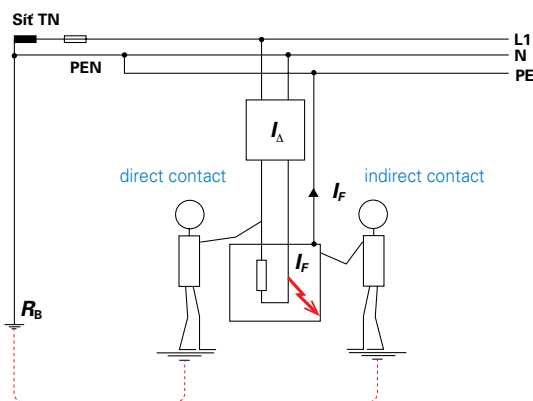

Fig. 52 Direct and indirect contact with a live part [11]

Fundamental electrical standard IEC 60364-4-41 - Protection against electric shock defines the concept of three-grade protection, as specified on Figure 51 and 52. The first grade is **basic protection**. In case of its failure, **fault protection must respond**. The top level grade is additional protection, where the most frequently used one is **additional protection by means of an RCD with sensitivity up to 30 mA**.

Electric shock may occur as a result of direct contact with live part or indirect contact when a person touches a conductive part that is normally voltage-free but touch voltage (U_T) is present on it due to a failure, see Figure 53.

4.1 Protection in case of failure

Protection in case of failure only responds in case of a failure - usually after insulation damage. This is the fundamental difference compared to the mission of basic protection, which prevents failure from occurring, whereas protection in case of failure must respond to a fault that already occurred.

The most frequently applied is **protection by automatic disconnection from power supply**. Power interruption must be ensured in sufficiently short time, when the hazardous impact of electric current on human organism has not yet started. Automatic disconnection requires coordination between power supply type (transformer, generator, ...), earthing system, impedance values of protective wiring system and protection device characteristics. Protective conductor PE is always necessary for correct function. The following systems are in use:

- in TN networks - overload protective devices or RCD;
- in TT networks - RCD;
- in IT networks - monitoring of insulation at first failure by means of insulation monitoring devices (IMD) or residual current monitors (RCM) and, in case of earth connection, automatic disconnection (fuses, circuit breakers, RCD).
- protection by interconnection - reduction of touch voltage between conductive parts exposed to direct contact;

Type of network earthing (TN, TT, IT) determines the rules for selection of sensitivity of RCD.

4.1.2 Protection in TT networks

Protection by automatic disconnection in TT networks consists in the connection of exposed conductive parts with earth and in using earth for conducting of fault current to the supply node. Wiring scheme of a TT network is shown in Figure 8. Earth resistance of protective earthing of an electric equipment must be sufficiently low so as to ensure timely disconnection of a fault. Permanent separation of neutral and protective conductor in the entire network is indispensable for a correct function of the network. In the event of a fault in a TT network, the exposed conductive part is exposed to a relatively high touch voltage (150 to 200 V) because the supply network voltage is divided in the proportion to the wiring impedance and earthing resistance. In case of contact by a person, such high voltage will cause a major electric shock, considerably higher than usual in case of a fault in a TN network. Another risk factor in a TT network is the likelihood of failure of an RCD, on which the protection by automatic tripping is directly dependent. For this reason, in a TT network, recommended to use two RCDs in series. The first RCD to be used in series is the main building RCD and the second one is a sensitive type for final circuits with $I_{\Delta n} \leq 30$ mA. Rated residual working current $I_{\Delta n}$ of RCD must not exceed the current corresponding to maximum earthing current value R_A of dead parts, whereas possible seasonal changes (drought, frozen soil etc.) are taken into account.

Maximum value R_A (Ω)	Maximum sensitivity $I_{\Delta n}$ (RCD)
2,5	20 A
5	10 A
10	5 A
17	3 A
50	1 A
100	500 mA
167	300 mA
500	100 mA
1666	30 mA

R_A is sum total of resistances of earth conductor and protective conductor to dead parts

Tab. 11 Selection of sensitivity of residual current in TT network

4.1.3 Protection in IT networks

IT networks are used, when maximum safety and high reliability in the supply of selected equipment is required. The benefit of IT networks is the ability of safe function even in case of occurrence of first earth connection, which would occur immediate triggering of protection device in a TT or TN network. Their disadvantage is more complicated operation.

An ideal IT network is isolated from earth over its entire range, only exposed conductive parts of electrical devices are earthed. In case of **first earth connection** (first failure), no current flows into earth and preliminary overload element does not trip. Thus, such an IT network becomes an earthed TN network. But, real IT networks differ from such ideal condition because every installation has certain leaking currents. In smaller networks, the body

current at contact is still sufficiently low as to cause an injury. In very extensive networks, earth leakage currents reach up to units of Amps. To identify first failure, insulation monitoring devices (IMD) or residual current monitors (RCM) are used, which must give audible or light signals, so that the work activity in progress can be completed safely.

If, in an IT network, **a second earth connection** (second failure) occurs at another place, the first earth connection causes short-circuit current and overcurrent protective devices must cause disconnection. Since the first and the second failure can occur at two contralateral ends of the installation, the denominator includes the figure 2 (impedance of conductors in two ways). Details are specified in standard IEC 60364-4-41.

Other extremities of the IT network face a problem with use of overload circuit breakers in case of a second failure, which is why an additional interconnection must be used or protection must be ensured by RCDs. But the situation is not as simple as in TT and TN networks. If a second failure occurs after the RCD, then it may not trip.

The fundamental rule for applying sensitive circuit breakers in IT networks is that their installation for the various outlets must be as close as possible to the appliance (see Figure 57). The wiring after the RCD must be considerably shorter than the installation before it.

A particular case are **isolated networks at hospitals** (MIS = medical insulated network) and is subject to specific requirements under IEC 60 364-7-710: Electric installations in medical premises. Based on the specific conditions of MIS, designing and operation should be only entrusted to qualified personnel, who are familiar with the particular requirements for medical installations.

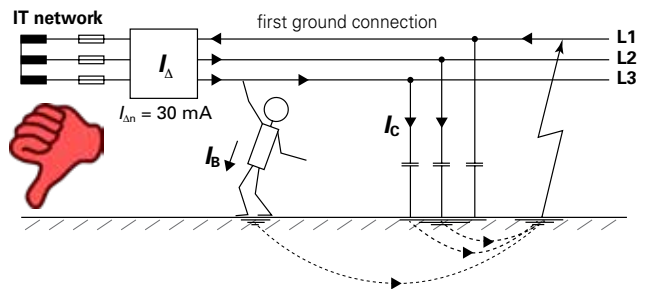

Fig. 56 Incorrect use of sensitive RCD in an IT network

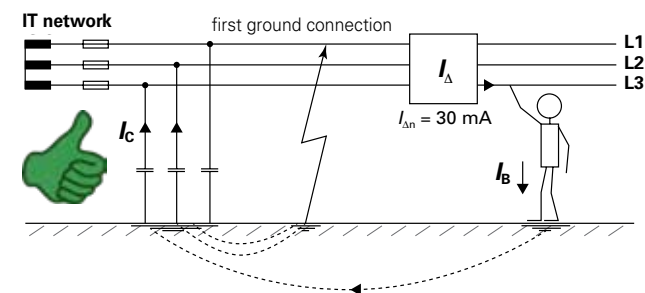

Fig. 57 Correct use of sensitive RCD in an IT network

4.2 Additional protection by RCD with $I_{\Delta n} \leq 30 \text{ mA}$

Despite all efforts for providing the best possible level of safety, there are situations when a high-quality insulation is damaged and water penetrates into an electric device, or contact with conductive live part occurs due to carelessness. In such case a sensitive RCD must be available. Therefore we talk about additional protection an RCD with sensitivity of $I_{\Delta n} \leq 30 \text{ mA}$.

Figure 58 shows cases when a sensitive residual current may save life.

However, the use of RCDs with a sensitivity of $I_{\Delta n} \leq 30 \text{ mA}$ is not considered to be the only possible preventive measure and does not eliminate the need to apply an electric shock preventive measure. For protection class I electric devices, such a preventive measure is mostly protection by automatic disconnection from the power supply, or, for insulation class II devices, protection by double insulation.

Mandatory application of residual current devices with $I_{\Delta n} \leq 30 \text{ mA}$ applies to all outdoor sockets up to a rated current of 20 A and to sockets where use for portable hand-held tools for outdoor use is expected. Protection by sensitive RCDs does not need to be applied in outdoor sockets only in exceptional cases, when a safety isolating transformer is applied, or in the event that the appliance is operated by a person with electric qualification or that the electric device has double insulation. However, the risk of damage to mobile power supply wires persists.

Use of sensitive RCD is prescribed in all cases with enhanced risk of electric shock. Type of network (TN, TT or IT) has no impact on the function of a RCD; provided that the particularities of the various types of network are taken into account.

a) Contact with live part

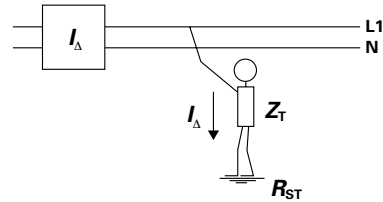

b) Insulation failure on class II device

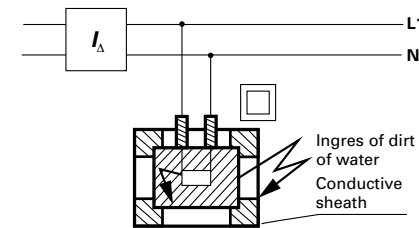

c) Interruption of protective conductor to protection class I appliance, interchange of working and protective wires

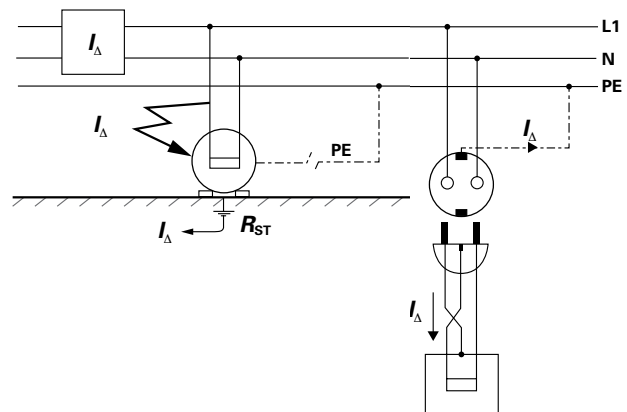

Fig. 58 Cases of additional protection with RCD with $I_{\Delta n} \leq 30 \text{ mA}$



„Give now to fix an electrical device that beat or stings“

Fig. 59 Historical safety poster (Czechoslovakia 1927)



Fig. 60 Historical safety poster (Austria 1925)

5. Protection against fire risk

Defects on electrical devices is a very frequent cause of fire. This reason is formally given even in cases when the actual cause cannot be found out. The easiest way is always to say that fire was caused by “short-circuit.” But experts know that perfect short-circuit is most frequently not worth considering because preliminary circuit breakers or fuses can disconnect electrical devices very quickly and short-circuit current energy mostly cannot initiate fire in such a short time (milliseconds). Much more hazardous in terms of fire are **long-term failures**, such as poor joints with high contact resistance that expose the connection to high thermal load in the long term and mainly cause insulation to become worn and degraded. These failures can be prevented by well executed assembly and by regular inspection. Especially hazardous are so-called creeping failures with poor earth connection with low currents that fuses or circuit breakers do not respond to. These types of faults cause tripping too late or not at all. If a failure has developed such that overheating or even subsequent short-circuit has occurred, the occurrence of fire is highly probable.

5.1 Protection against leakage currents

Where even a relatively low leakage current could cause **local overheating of insulation** or flammable conditions, high-grade cable insulations must be used in combination with a suitable RCD with sensitivity up to 300 mA. Such sensitivity is supported by measurements that have confirmed that dissipation power of 20 to 100 W is sufficient for igniting wood, hay, straw and other usual flammable materials. Considering the tripping current tolerances, tripping occurs as early as a dissipation power of around 40 W.

Minimum requirements for the use of electric devices in areas with high risk of fire are prescribed by actual standard IEC 60364-4-42 Fire prevention in premises with particular risk or hazard. This standard stipulates mandatory use of RCDs with $I_{An} \leq 300$ mA in all cases where an electric device is in contact with combustible materials. The main cause of insulation defects followed by **creeping currents is thermal and mechanic strain** and other harmful external impacts. High temperatures cause continuous evaporation of softeners from the most frequently used PVC insulation, which causes it to become harder and porous. Changes in ambient temperature also involve changes in humidity, together creating conditions for occurrence of impermissible charges and creeping currents, see [Figure 61](#) and [62](#).

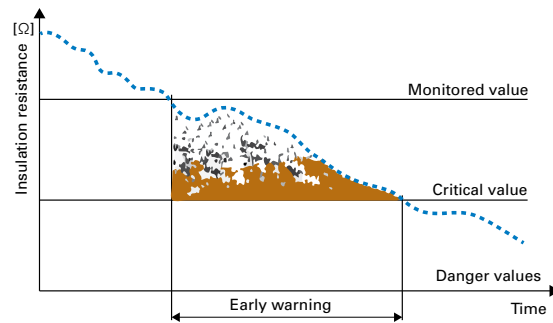

Fig. 61 Drop of insulation resistance in electric installations and devices due to insulation ageing



Fig. 62 Fire occurrence due to creeping currents



Fig. 63 Fire at Hofburg Castle (Vienna, 1992)

5.2 Protection against serial arc (AFDD)

Fire statistics imply that there are numerous cases of fires caused by arcing between working conductors, where no fault was recognized by an RCD. However, beside earth fault currents responded to by an RCD, there are also other fault currents that only occur between working conductors, which RCDs cannot respond to. If the impedance of the fault circuit is not sufficiently low to ensure circuit protection tripping, the risk of fire due to a persisting fault will rise. Another fault risk is the so-called **series arc**, which occur at the point of working conductor interruption. Although this topic is not mainly focused on protection by RCD, it is closely related to it. Therefore we will address it in detail.

Most frequent cases of serial arc:

- disturbed wiring insulation in fixed installation (by nail, bolt, etc.)
- pinched insulation of mobile power inlet or extension cord, where cables are located between or below doors or trapped under appliances (dishwasher, washing machine, dryer, etc.)
- broken cables due to sharp edges or broken insulation by clips.
- UV radiation
- unprofessional installation, insufficient number of clips etc.

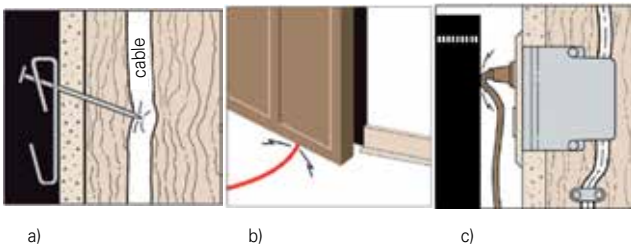
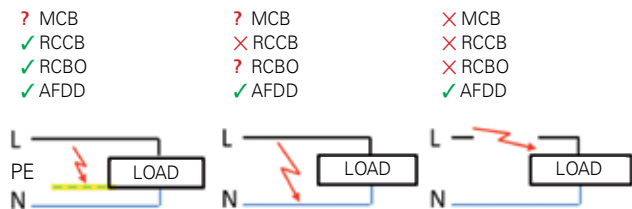

Fig. 64 Faults involving the occurrence of arcing that RCDs cannot respond to

In case of serial arc, the fault current will not exceed rated current of the device but the temperature of insulation will increase and eventually carbonize. This may rapidly cause a fire. Another hazardous situation is gradual increase of contact resistance of joints and increase in their temperature. If this fault is not detected in a timely manner, it may cause the insulation to ignite.



MCB – miniature circuit breaker
 RCCB – residual current circuit breaker
 RCBO – residual current circuit breaker with overload protection (MCB + RCCB)
 AFDD – arc protection

Fig. 65 AFDD (arc fault detection device) improves the quality of protection with RCD in case of parallel and series failures

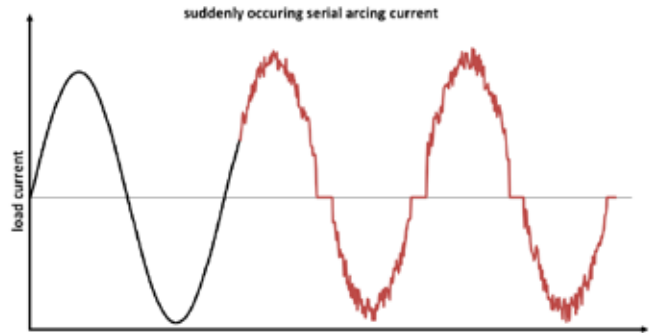

Arc generates high frequency signal from 100 kHz to 70 MHz
 Arc stops during voltage zero-crossing

Fig. 66 Example of current flow in case of serial arcing

The newly introduced AFDD (Arc Fault Detection Device) is intended to reduce the risk of fire caused by serial arcing, or in the event that current flows between working conductors (parallel fault current), when RCD is unable to react to such a fault, or when the fault current does not reach the values of rated residual operating current. An AFDD is an electromagnetic switching device with electronic circuits that monitor the character of current. Arcing has a specific current passage and the AFDD reacts to it by disconnecting the circuit with an insulation fault. By automatic disconnection an AFDD is able to protect an installation from damage by arcing and from thermal impacts such as cable burning. Standard IEC 62606 applies to these devices. The application of these devices is mentioned in the new standard IEC/EN 60364-4-42: (2015) – Protection against thermal effects.

To increase safety it is recommended to apply special measures for protection against the effects of arcing in the following cases:

- in premises with fire risk with respect to the nature of processed or stored materials (such as garages, wooden material shops, stores of combustible materials);
- in premises with combustible structural materials (such as wooden buildings);
- in premises with possible hazard to irreplaceable goods;
- etc.

AFDDs can reduce the risk of fire also in premises for elderly or handicapped persons.



Fig. 67 AFDD in compact version with RCD and MCB

6. Limits of applicability of RCDs

RCDs face certain limitations in application, due to their functional principle. The following points specify the most frequent cases when a RCD cannot be applied and protection must be provided by other methods.

- **Short-circuit between working conductors**

Figure 68 shows the case of short-circuit between live conductors, i.e. phase to phase (L-L) or phase to neutral (L-N). This fault must be tripped by a circuit breaker or fuse. Similar situation will occur with contact between two working conductors.

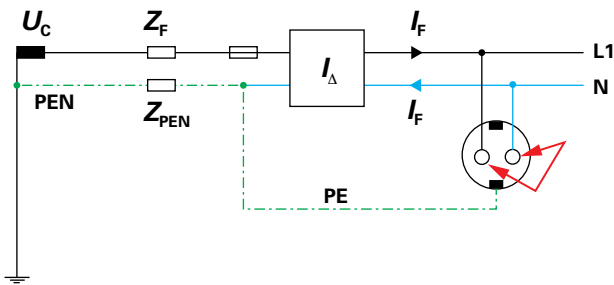

Fig. 68 Short-circuit between live conductors after the RCD will not ensure its tripping

- **Surge currents in live conductors** – suitable coordination must be evaluated and correct connection must be applied.

- **Constant leaking currents** - the affected circuit must be divided to separate circuits or protective measures must be applied, where no RCD will be applied (e.g. protective interconnection).

- **Interruption of PEN conductor before RCD**

In case of interruption of PEN conductor (TN-C network), dangerous contact voltage will occur on exposed conductive part. In case of person's contact with this part, the body impedance is evaluated as working current and the RCD has no reason for tripping. A solution is prescribed in partial earthing of PEN conductor and PE conductor at the last point of separation (switchboard, installation case). This measure reduces contact voltage on the exposed conductive part and at the same time guarantees reliable tripping of an RCD in case of contact by persons.

- **External impacts and inadequate shield** - RCDs are mostly designed for household and similar use, which is why they are expected to be applied in normal conditions. Ingress protection is IP20 (touch by finger) and the device works reliably only in the expected basic environment. In environments with high humidity, aggressive environment in chemical plants, swimming pools etc., high ingress protection and/or forced ventilation of switchboard from normal ambience without occurrence of harmful substances must be provided.

- **Protection against fire in case of arcing between working conductors** – necessary combination with arcing protection device - AFDD (engl. Arc Fault Detection Device). (see chapter 5.2)

7. Reliability of RCD

7.1 Operational reliability

Long-term research and verification of functionality of protective measures in tens of thousands of low-voltage installations worldwide have proven that there is a certain limit to the reliability of RCDs that needs to be taken into consideration. Voltage-independent and voltage-dependent types have proven to provide comparable reliability. The failure rate in the period under consideration of 10 years was fluctuating between 3 and 5 percent. Extensive research of reliability took place from the 1960s on but most of it was carried out in 1980s in Austria, Germany and Italy. Over 30 years of use, which is a usual period of installation life, the number of non-functional units will rise up to 10 percent. Although the likelihood of RCDs failure in units of percent over ten years is considered a relatively high risk, the likelihood of human error is many times higher over the same period of time! Therefore, the highest possible reliability of protective measures must be pursued and these measures must be in operable condition at all times.



- Also suitable for higher leakage current values (reduced limited tolerance)
- Tripping characteristics G and S
- Indication of residual current value (digital evaluation)

Fig. 69 Digital RCD with enhanced reliability with annual testing interval

When focussing only on voltage-independent types of RCDs that are accepted in all countries, a possible solution is targeted selection out of serial production with restricted tolerances of parameters in consideration. All types with increased reliability are delayed types with the benefit of impulse tripping from energy accumulator (capacitor). Selected parts and subsequently also completely assembled devices are subject to more demanding electrical, mechanical and climate tests. Based on the results of long-term service life tests, a higher reliability of the entire RCD can be guaranteed. This also involves prescribed intervals of regular checks by means of the test button, extended to six months and, for some types, even up to one year (see Fig. 70).

Note:

One of the solutions was a design of RCD with high reliability, utilizing a combination of the most reliable structural parts of voltage-independent and voltage-dependent types of devices (type HFI by Prof. Dr. Biegelmeier, Austria Patent No. 387675 B, 1988). Serial production was introduced by Felten&Guilleaume. Correct function was guaranteed without necessary testing for the entire service life of installation. The new solution used supply network voltage for reliable tripping, which is why it could not be completely voltage-independent by principle. This was why it was not adopted in countries where full voltage independence is still required even when there are no safety reasons for that.

7.2 Regular testing functions

Testing the function of an RCD by pushing TEST button must take place in time intervals prescribed by manufacturer [22] or based on the requirements of local operational rules taking into consideration the specific local conditions (humidity, dust, temperature variations etc.). Regular testing is the responsibility of equipment operator. Most usually, the required inspection intervals are monthly or half-annually.

Longer testing intervals are required in uninterrupted production premises where an outage for inspection and maintenance purposes is possible for instance only once a year. There are also completely extraordinary situations when installation cannot be switched off for a very long period of time. This is typically the case of emergency wards in hospitals where beds are constantly occupied and power supply cannot be deactivated for the purposes of mere inspections. For such applications, types with longer guaranteed testing intervals must be purchased. Whatever rules the operator adheres to, it is essential that functional testing be carried out.

Eaton recommends testing in the following cases:

- immediately after installation
- immediately after modifications of installation
- regular testing (with due consideration of ageing):
 - normal household and similar installations (dry, dust-free environment) - 6 months
 - other installations (outdoor circuits, manufacturing premises) - 1 month
 - all types with time delay (G, S, R, U) - 6 months
 - digital RCD - 1 year

If the RCD is used for automatic fault disconnection, then the overload protective device, which is always integrated in the installation anyway, will be still functional even in case of RCD failure. But for additional protection of live parts, reliability plays a particularly significant role. A sensitive RCD is the last security in case other protective measures have failed, and ultimately may save life.

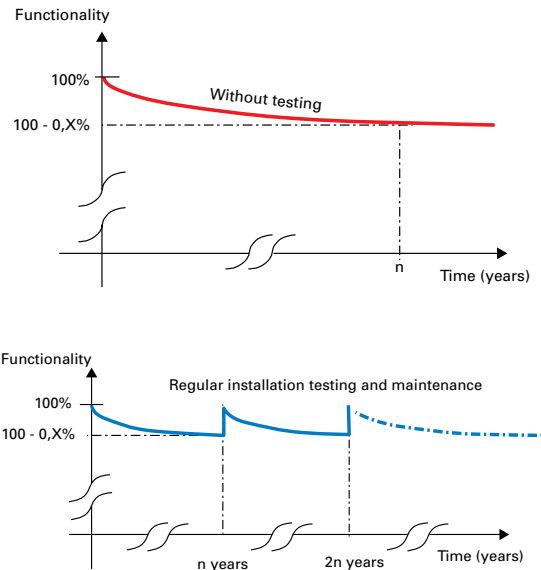

Fig. 70 Theoretical functional dependence of RCDs without testing and at regular testing [22]

Note:

A significant improvement of reliability is demonstrable in newer types of RCDs. This is directly impacted by the introduction of climate testing that was additionally introduced to product standards for RCDs at the end of the 1990s. All currently valid standards require fault-proof testing, which involve 28-day climate resistance tests with cyclic heat exposure up to +55 °C and with humidity of 95 %. After this test, an RCD must trip at the residual current value of $I_A = 1.25 \times I_{\Delta n}$. It is also recognized that climate tests might impact the parameters of an RCD, wherefore additional equipment with higher current value than rated current value is permitted. The recommended monthly testing interval, specified by manufacturers for usual types of RCD approximately corresponds to the duration of the climate resistance tests.

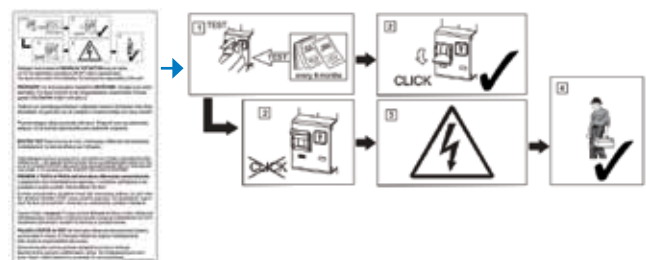

Fig. 71 Label with warning of mandatory regular testing Z-HWS-FI

8. Measurements of RCD during verifications

Methods of RCD measurement are relatively simple and based on the wiring principles specified in product standards, see Fig. 72. Measurements are executable by means of general laboratory measuring devices. The purpose of measuring at a test lab is to verify product properties in the course of type tests, i.e. only the independent device. On the contrary, measurement of RCD properties in the course of verification checks is intended to provide **complete information on (non-)fulfilment of safety conditions in the installation**, where a RCD device will be applied. In the course of a verification check, fulfilment of safety conditions of electrical installations is verified. An important step is measurement verifying the basic parameters including tripping and non-tripping currents of the RCD. **Requirements for verifications are specified under IEC 60364-6: Verifications (2007).** Verification of effectiveness of protective measures in case of failure by automatic disconnection from power supply takes place by verifying characteristics of the RCD and by measuring fault loop impedance. The wording of standards regulating verifications differs depending on national deviations, which must be taken into consideration.

Procedures of measurement in measuring devices intended for verifications are stipulated by the requirements of product standards for RCDs and their design is subject to requirements defined by the standard regulating the design of verification devices (EN 61557-6). The method of measurement depends on the solutions of the various manufacturers.

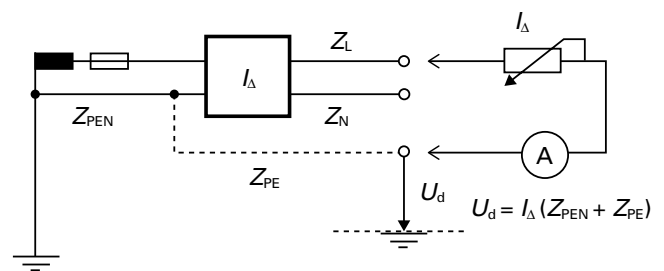

Fig. 72 Principle of measuring residual current and contact voltage in TN network

Note:

Measurement accuracy in all new measuring devices must comply with the requirements of the standard for verification devices (set of EN 61557 standards) and corresponds with the purpose for which the measurement is carried out. If measurement in the course of verifications takes place with an interval of several years, it makes no sense to insist on high accuracy and to hold long discussions on possible causes of minor deviations of the revealed values of tripping times and currents as compared to the latest measurement. Additionally, also the results obtained from two measuring devices often differ, which is attributable to the applied measurement method. From the point of view of safety, it is much more important to make sure that regular functional checks are carried out by means of test button, giving a clear trip/non-trip result.

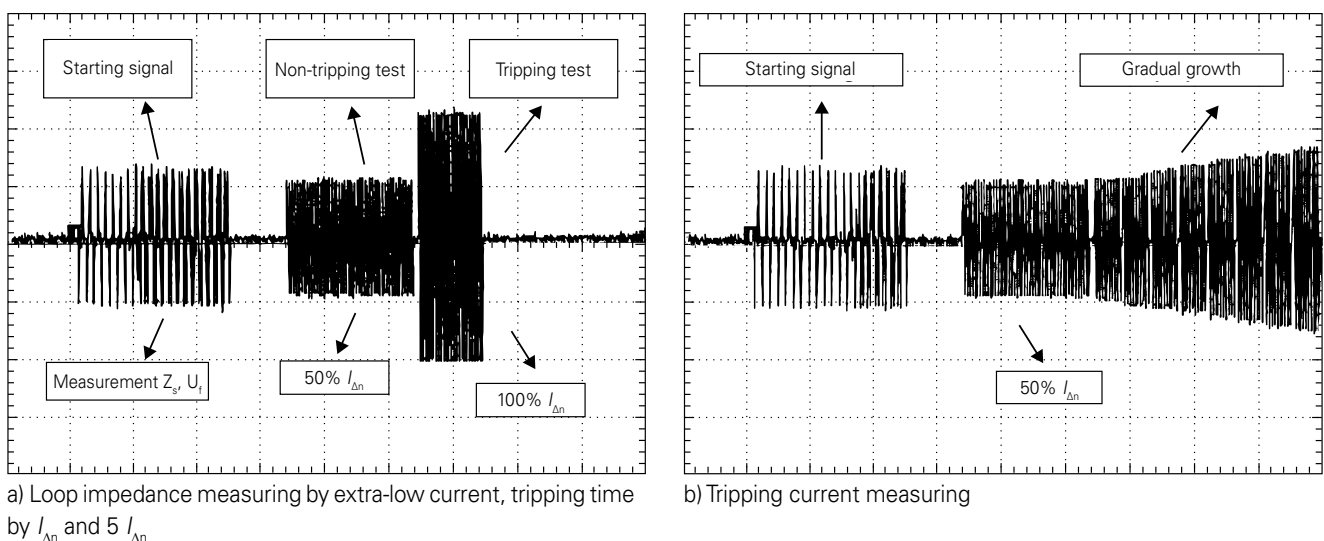

Fig. 73 Examples of passage of measuring currents of a combined device

9. Connection in installations

The fundamental principles for installation of RCD are as follows:

- all live conductors necessary for the function of appliance must pass through the RCD;
- live conductors after the RCD must not be connected with live conductors after another RCD;
- protected exposed conductive parts must be earthed;
- protective conductor (PE, PEN) must not pass through the RCD; exceptions are permissible only in specified cases (see Fig. 44);
- division of PEN conductor in a TN-C network to separate PE and N conductor must be executed before the RCD – necessary conversion of TN-C network to TN-C-S;
- PE and N conductors after the RCD must not be re-connected – this is the cause of frequent problems with unwanted tripping;
- prior to commissioning, the RCD must be tested, including a verification of separation of PE and N conductors.

9.1 Incomplete number of live conductors

The function of some three-phase appliances does not require a neutral conductor (asynchronous motors) or are only designed for operation on two phases. Some electrical engineers then ask whether the missing N conductor will not cause unwanted tripping of RCD. The answer is easy - if no residual current occurs in the circuit after the RCD, then the number of loaded conductors will have no impact on the function of RCD.

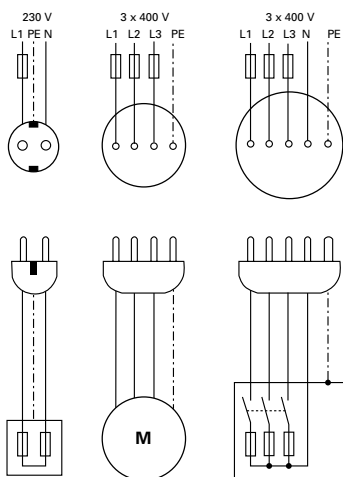

*) unconnected neutral or either of the phase conductors have no impact on RCDs safety and correct function

Fig. 74 Connection of plugs and sockets in installations with three-, four- and five-core distributions

9.2 Constant leaking currents

Every electric appliance or installation shows a certain level of constant leaking current that is determined by the quality of electric device insulation, design, ageing and the effect of external impacts (humidity, heat ...).

Basic information on the values of alternating leaking currents is specified in IEC/EN 61140 ed. 2 [18], based on which the manufacturers should apply the following limit values:

a) electrical devices connected by plug for one-phase and multi-phase socket circuits with currents up to 32 A, including:

Current of equipment I_n	Max. current through PE conductor
up to 4 A	2 mA
4 A to 10 A	0,5 mA/A
above 10 A	5 mA

b) Constantly connected electrical devices and non-portable devices with currents above 32 A:

Current of equipment I_n	Max. current through PE conductor
up to 7 A	3,5 mA
7 A to 20 A	0,5 mA/A
above 20 A	10 mA

c) constantly connected electrical devices intended for connection to strengthened protective conductor for currents above 10 mA [18]. Cu conductor with a section of at least 10 mm², or 16 mm² Al is prescribed as a strengthened protective conductor. In these cases, the use of RCDs with sensitivity up to 30 mA is limited or entirely ruled out.

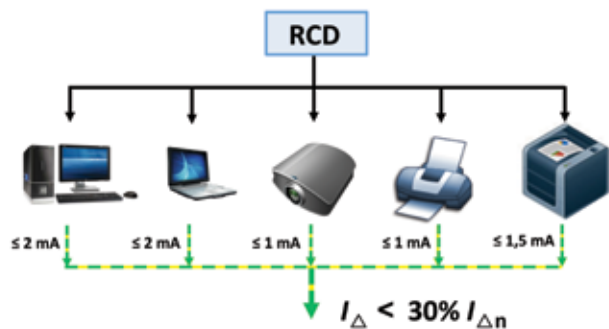

Fig. 75 Leaking current of office equipment

Typical values of leaking current:

- computers 1 - 2 mA
- print machines 0,5 – 1 mA
- copy machines 0,5 – 1,5 mA
- filters, ilumiscent lights 1 mA

In any installations with higher level of leakage currents it is appropriate to ensure their continued control. It is advantageous to use a digital RCD with integrated signal indicator and the possibility of remote signalization of exceeded values of residual current (50% $I_{\Delta n}$).

9.3 Grouping of circuits behind one RCD

The range of installation and optimum connection method must be taken into consideration as early as in the course of project design stage. From the perspective of protection against injury, one sensitive RCD can be applied at the beginning of the entire installation, but such a solution would involve many complications:

- in case of failure in any circuit, the whole installation will be disconnected after the tripping of preliminary RCD;
- in case of any fault on the connection of neutral conductors, the shared preliminary RCD will trip;
- when searching for wiring errors, the entire installation must be switched off;
- leakage currents in the installation are summed up; any additional leakage current may cause the RCD to trip.

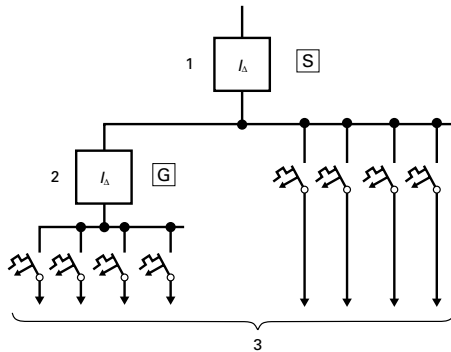

- 1 - selective RCD at the input
- 2 - grouped circuits after RCD type G
- 3 - division of circuits by importance of load

Fig. 76 Recommended coordination between installation circuit breakers and RCDs [4]

Resistance to unwanted tripping with grouped circuits after one RCD will improve considerably when the circuits are subdivided into various groups. Figure 76 shows possible connection in a household installation. Selective type with sensibility of 300 mA is applied at the input, providing at the same time fire prevention. For most socket circuits, additional protection by sensitive RCD (30 mA) is required. Selecting type G will provide high resistance to unwanted tripping. In the event of a short-circuit after the circuit breaker, with preliminary delayed RCD type G, then such short-circuit will be typically disconnected by circuit breaker within maximum 10 ms (tripping sensitivity depends on the short-circuit current value).

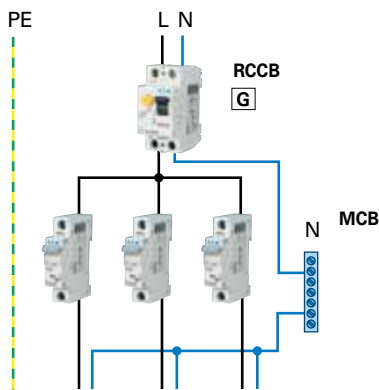

Fig. 77 Grouping of circuits behind RCD

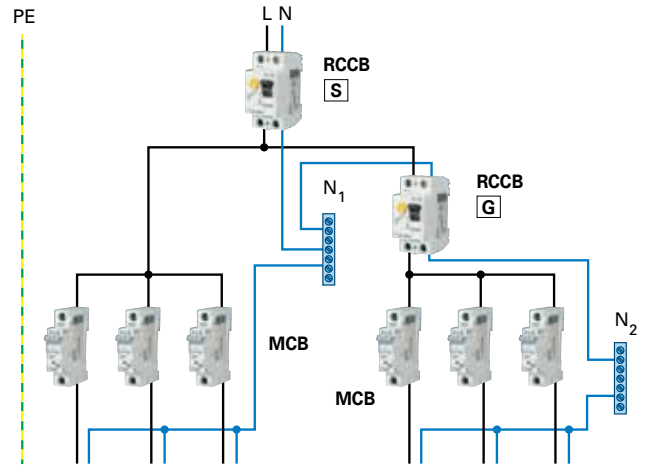

Fig. 78 Selective grouping of circuits after RCDs

For this period of time, the delayed RCD is inactive and the rest of installation therefore is not affected by fault on one circuit. Lighting circuits and dedicated sockets (refrigerators, freezers, heating pumps, computer servers) are free of additional protection. A compromising solution between the number of outlets and appliances and the number of installed RCDs is found in case of household installations. Practical experience shows that for a detached house or a larger apartment for instance, the optimum number of RCDs is 3 to 5, which is sufficient for adequate division of independent parts of the installation.

An improved method of protection is the use of RCDs with switched neutral conductor (Figure 79). Its benefit is disconnection of all working conductors (1+N, 2+N, 3+N) and easier localization of faults in installation, where the various circuits must be disconnected one by one, including the neutral conductors. Several years ago, this practice was adopted in Austria and showed very good results. Another improvement is the use of independent combined residual current devices (RCBOs) with a sensitivity of $I_{\Delta n} \leq 30$ mA for the various outlets.

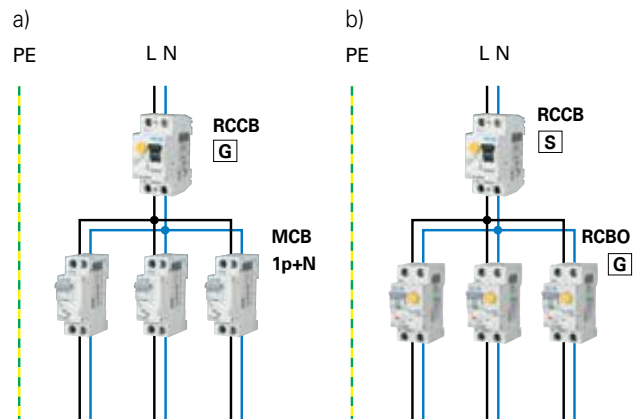

Fig. 79 Use of 1+N and 3+N circuit breakers or combined residual current devices (RCBOs) after a shared RCD

9.4 Coordination with surge protective devices (EMC)

Effects of overvoltage in building installations is eliminated by means of surge voltage protectors. On the input into the installation, the residual voltage behind surge voltage protector class I (class B under VDE standard) must not exceed the value of 4 kV; for class II (class B respectively) this limit is 1.5 kV. **From the perspective of an RCD, every earth leakage current is evaluated as residual current, wherefore surge voltage protectors are not intended to be installed after an RCD.**

Recommended connection of installation with RCDs and surge protective devices is depicted on Figure 80. In socket circuits with an RCD with a sensitivity of 30 mA, type G with short-term delay and endurance up to 3 kA must be used. For protection of exposed conductive parts, use selective types S with endurance up to 5 kA. Usual values of nominal pulse currents of surge voltage protectors class II (C) are 10 to 25 kA, for surge voltage protectors class III (D), this value is 1.5 to 3 kA. This implies that the endurance of the entire installation is determined by the endurance of RCD.

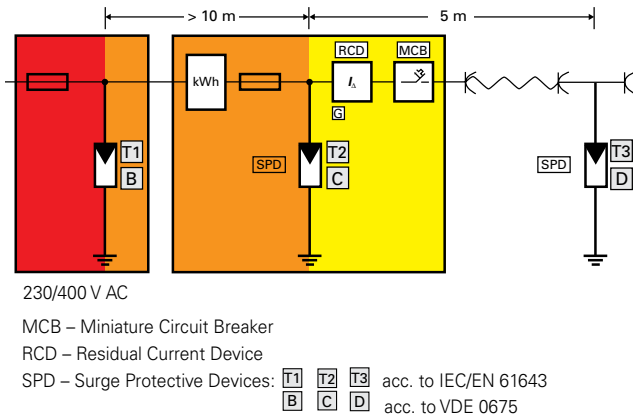

Fig. 80 Coordination of RCD and surge protective devices

Note:

EMC - Electromagnetic compatibility. Test conditions and EMC performance criteria are indicated in the EMC product family Standard for RCDs (IEC 61543 [20]).

Figure 81 shows the typical wiring of conductors (connection 4+0). Its benefit is simplicity, a disadvantage is worse protective properties, consequently this connection is not recommended. Another disadvantage is higher residual voltage between live conductors, which equals to twice the residual voltages of the various surge protective devices. Overvoltage protection between live conductors is more important than reduction of voltage to earth.

Figure 82 shows connection with shared spark gap between conductors N and PE, marked as 3+1 (for one-phase wiring as 1+1). Its benefit is the reduction of current passing through the spark gap to earth. Overvoltage between working conductors is mainly limited by surge protective devices that are connected between phases and neutral conductor. Spark gap connected between neutral and protective conductor is initiated only when voltage on N conductor exceeds the limit of its ignition voltage. In normal conditions, this provides high insulation resistance between PE and N conductors.

Based on the conditions of electric shock protection, either delayed types G for additional protection should be used, or, at the beginning of installation, type S (protection of exposed conductive parts).

This connection principle is nowadays applied in most surge protective devices class III (D) for protection of one-phase appliances in 1+1 wiring, which has a favourable impact on unwanted tripping of sensitive surge protective devices.

Thus, the conclusion is that due to difficulties in coordination of surge protective devices with RCDs, **surge protective devices should only be installed before RCDs** (see also appendix IEC 60364-5-534). If surge protective devices must be used after the RCD, then resistance to surge current is determined by the resistance of the RCD (type G up to 3 kA, type S up to 5 kA).

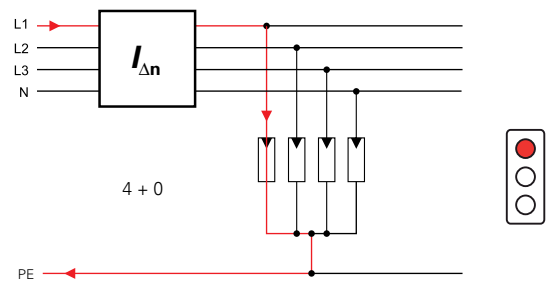

Not recommended connection!

Every current passing through surge protective device is at the same time residual current!! Indispensable use of surge protective devices with enhanced resistance to surge currents - types G or S.

Fig. 81 Surge protective devices in wiring 4+0 (1+0)

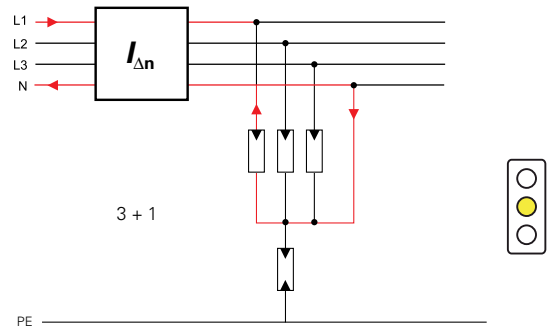

Not recommended connection!

3+1 for 3 phase installations, 1+1 for 1 phase installations
Only current passing through summation spark gap is residual current.
Indispensable use of surge protective devices with enhanced resistance to surge currents - types G or S.

Fig. 82 Surge protective devices in wiring 3+1 (1+1)

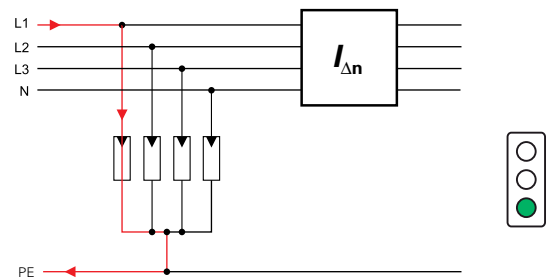

Recommended connection.

Surge protection devices of type II (C) is necessary to connect before the RCD.

Fig. 83 Surge protection devices connected before the RCD

9.5 Application of RCD types AC, A and B

Electrical devices that contain power rectifiers and semi-conductor switching elements may, in case of failure, inflict residual current with direct current components. When assessing possible risks of RCD failure, it must be determined what type and sensitivity are actually necessary. One of the selection criteria is type of protection, meaning whether protection in case of fault for class I devices, where the sensitivity of RCD is not critical, or additional protection, where the required sensibility is 30 mA.

In **household installations**, only types AC and A of RCDs are considered. At present, the number of countries that only A types are permitted in new installations is rising. Type A are preferred in new installations, it represents a better solution.

The situation is more complicated in **industrial installations**, where frequency inverters for controlling the speed of asynchronous motors is becoming more and more common, as well as in photovoltaic power station installations (DC/AC converters). In these cases, manufacturers of converters and frequency inverters are obliged to advise of the possible generation of residual currents and ideally to specify the type of RCD to be used. Where such information is not specified in the operating manual, it must be obtained from the manufacturer. Unfortunately, usually no concrete information can be obtained and only required advice is given that "type B RCD should be applied in the event that a DC component of fault current may occur in case of failure." In most cases, however, it is not obvious how the equipment will react during possible failure and correct information can only be provided by its manufacturer. So what type of RCD should be actually used?

Standard IEC/EN 50178 - **Electronic equipment** provides a good guideline as it includes a description of applications with power elements and instructions for possible solutions depicted in Figure 84. The specified output values up to 4 kVA for mobile connections are only for reference (e.g. German version VDE 0160 specifies equipment current up to 16 A). For lighter appliances with mobile supply cable, their hand-held application is expected, which is a significant criteria for the selection of sensitivity of RCD (30 mA). Sensitivity of 300 mA is usually used for class I fixed equipment. Inverters in six-pulse bridge circuits, directly connected to three-phase supply network, are used for controlling higher outputs. In such cases, type B RCDs are required (see IEC/EN 61008 and IEC/EN 62423).

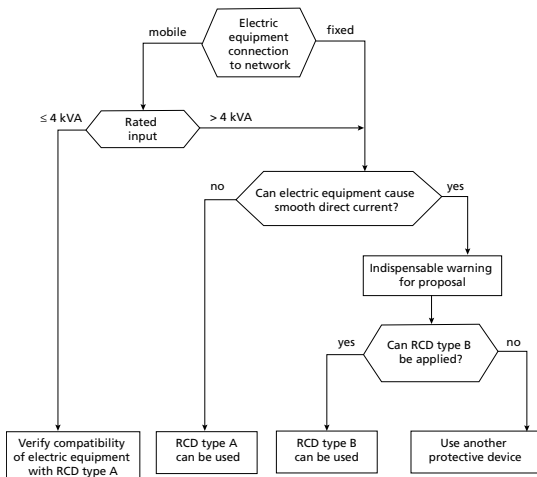

Fig. 84 Wiring diagram for determining requirements when using electric devices after RCDs

	Circuit diagram with fault location	Shape of load current I_L	Shape of earth fault current I_f	RCD tripping characteristic			
				AC	A	F	B
1	Phase control			•	•	•	•
2	Burst control			•	•	•	•
3	Single-phase				•	•	•
4	Two-pulse bridge				•	•	•
5	Two-pulse bridge, half controlled				•	•	•
6	Frequency inverter with two-pulse bridge					•	•
7	Single-phase with smoothing						•
8	Frequency inverter with two-pulse bridge and PFC						•
9	Two-pulse bridge between phases						•
10	Frequency inverter with two-pulse bridge between phases						•
11	Three-phase star						•
12	Six-pulse bridge						•
13	Frequency inverter with six-pulse bridge						•

Tab. 12 Possible fault currents in systems with semiconductors and example for coordination of RCDs of different types [14]

Application of RCDs types AC and A

Type AC RCDs are applicable in installations with only passive elements (resistors, inductances, capacitors), ruling out the occurrence of direct currents. Equipment with powerful semi-conductors can, in case of a fault, generate residual currents with direct-current components. Type A RCDs are to be used in these cases, capable of reliable function also in one-way rectification, when current passes through zero or is close to it with direct-current component 6 mA (see Fig. 25). For type F, designed for circuits with frequency inverters, the limit of direct-current component is 10 mA.

Application of RCDs type B

Type B must be applied in circuits with smoothing capacitors, with the agreed value direct-current component (6 mA for type A, 10 mA for type F). This concerns nearly all electric equipment with power electronics in three-phase wiring without galvanic separation (transformer). This is the case of more powerful frequency inverters, medium-sized backup power supplies (UPS), welding units etc. Electrical equipment manufacturers should warn about this situation because they have detailed knowledge of the design of their products. This duty is anchored also in standard IEC/EN 50178 [23].

At present, various alternatives of RCDs are available, as described below:

- **type B:** for general use in circuits with frequency up to 1 kHz, or as per manufacturer's specifications (e.g. up to 2 kHz) as per IEC/EN 62423, IEC 60755
- **type Bfq:** special version for frequency inverters up to 20 kHz, sensitivity up to 300 mA; as per IEC/EN 62423;
- **type B+:** special version intended for protection against fire, sensitivity up to 420 mA; parameters defined according to German standard VDE 0664-400;

In the event that nothing specific is given in the documentation, manufacturers must be prompted to provide such information. After all, if no reliable information can be obtained, the only possible solution is to assess such electrical equipment based on the data available and to proceed according to instructions on Figure 84.

When the method of connection of electrical devices is known (see Tab. 12) the following basic rules for selection apply:

- **type AC RCD must not be used together with frequency inverters** because fault currents are not purely alternating.
- **one-phase supplied rectifiers** (frequency inverters, photovoltaic converters, UPS) use four-pulse wiring and working current is thus a combination of alternating and pulsating direct current. Pulsating direct current touches zero between two pulses, or DC component does not exceed the value of 6 mA (10 mA for type F), which means that in case of a fault, the core of the current transformer will not be saturated by direct residual current. Therefore, type A can be used, but most suitable is obviously the selection of **types F or U**, which are designed explicitly for this purpose.
- **three-phase supplied rectifiers** (frequency inverters, UPS) use six-pulse rectification. Fault current does not pass through zero, which may cause oversaturation of the RCD due to direct residual current. Therefore, **type B (Bfq, B+)** must be used

Figure 85 shows combination between the various types of RCDs in industrial installations. Type A or AC RCD must not be placed before a type B RCD. Similarly, type AC must not be placed before type A.

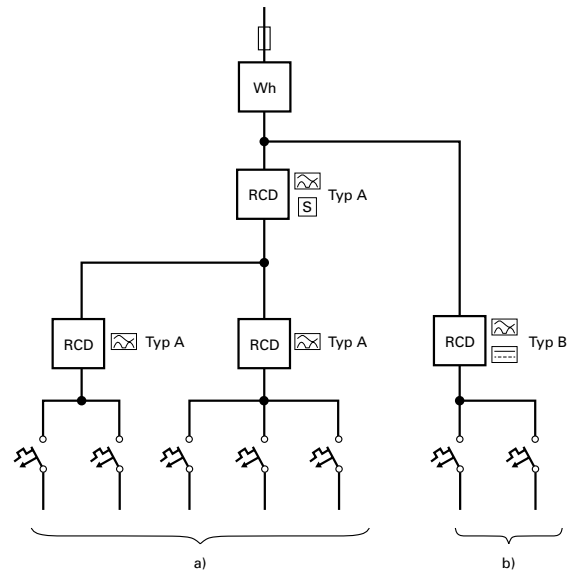

Fig. 85 Example of correct coordination of RCD, type A and B

RCDs in circuits with frequency inverters

Functional principle of frequency inverter is specified in Figure 86. Voltage with network frequency is rectified and electric energy is accumulated on direct current (DC) intermediary circuit. Based on output, rectifiers are designed as one-phase, two-phase or three-phase. This also determines if it is possible to use RCD type A (F, U, ..), or if type B must be used (see Table 12). Direct voltage obtained from DC intermediary circuit is converted to alternating voltage by means of a current inverter with pulse frequency modulation. Clock frequency is usually in units or tens of kilohertz. Due to inductance of motors, load current changes the harmonic waveform, which may approach purely sinusoidal waveform. To increase inductance and thus also quality of regulation, sinusoidal filters are used. In case of failure of asynchronous motor, residual currents with variable pulse width and frequency corresponding to clock frequency are generated. Due to non-harmonic waveform on converter output, at least the most important harmonics must be taken into account (3rd and 5th harmonic). The RCD must be able to react to them but at the same time it must comply with limiting tripping currents. Depending on the purpose of use, these devices are usually intended for fire protection (300 mA) or protection of persons (as per IEC/TC 60479-2: Effects of current on human beings at higher frequencies). Problems with undesirable tripping can be avoided by suitable choice of RCD type. This should be addressed as early as in the design stage in order to avoid subsequent problems during commissioning, when any subsequent measures taken are costly.

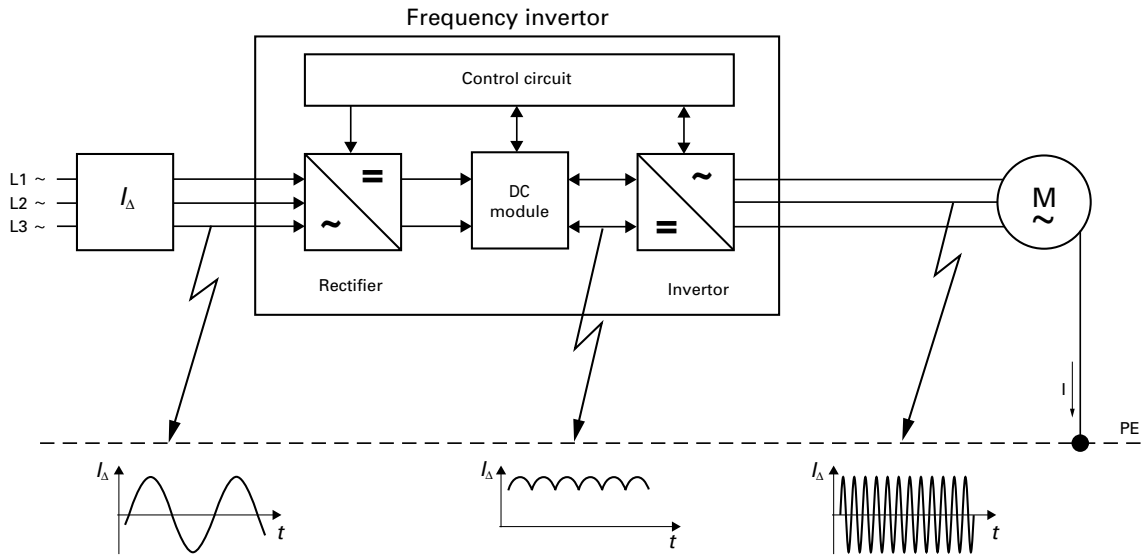

Fig. 86 The occurrence of direct earth fault current in circuit with frequency inverter with three-phase supply

Earth leakage currents at higher frequencies

Interference filters must be used in order to secure conditions of interference suppression (EMS) of frequency inverter. With increasing frequency, they show negative influence to capacitors connected to a protective conductor. High values of leakage currents limit or sometimes even rule out the use of RCDs. In general, the sum total of leakage currents should not exceed the value of non-tripping current (i.e. 50 % $I_{\Delta n}$), the recommended limit is up to 30 %. Connection of capacitors to protective conductors is more frequent but least suitable. Specialized manufacturers of interference filters offer types with minimize leakage currents that are designed for circuits after RCDs. Details of the values of residual currents will be provided by the manufacturer. Possible connection is depicted in Figure 87.

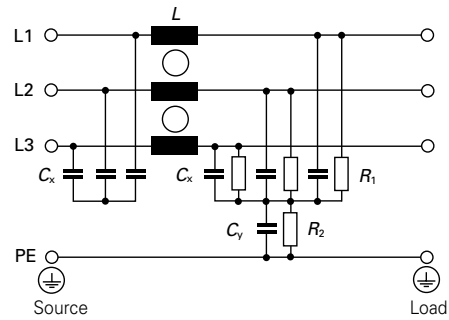
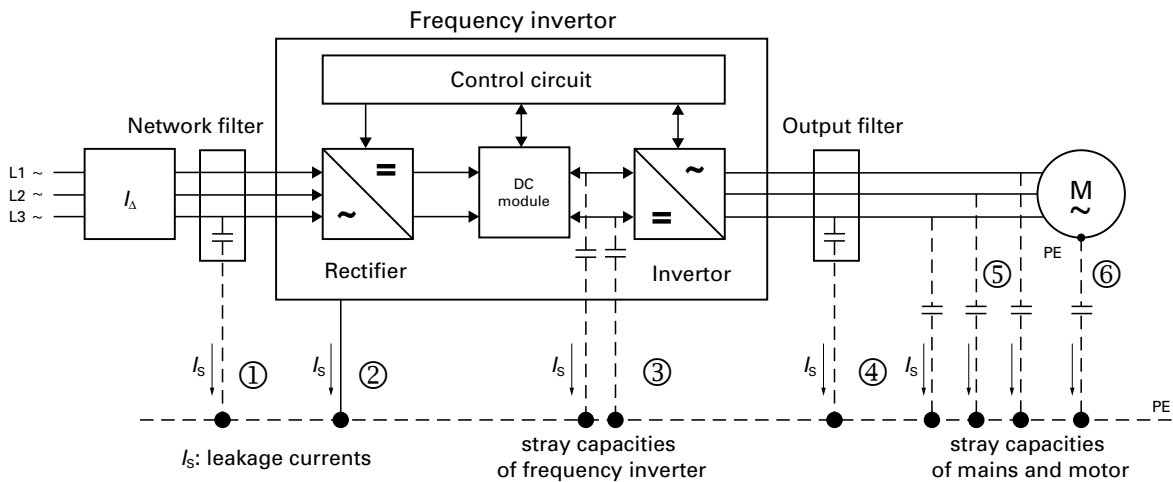

Fig. 87 Example of connection of filter with limited occurrence of residual current



① EMC filter, ④ filter on load side, ⑤ shielded cable behind frequency inverter, ⑥ motor

Fig. 88 Typical causes of leakage currents in circuits with frequency inverters

At present, the use of RCDs type B is referenced in the following standards:

- IEC 60364-5-53 - Switchgear and controlgear
- IEC 60364-7-704 - Construction and demolition site installations
- IEC 60364-7-710 - Electrical installations in medical locations (type AC are not permitted)
- IEC 60364-7-712 - Solar photovoltaic (PV) power supply systems (type B+ will preferably used) *)
- IEC 60364-7-723 - Floor heating

*) The purpose of use of type B/B+ RCDs is protection against direct-current leakage currents and fires. Type B RCDs or residual current monitors (RCM) are required on the alternating side of the power supply when no electrical separation between DC and AC side (without separating transformer) is applied.

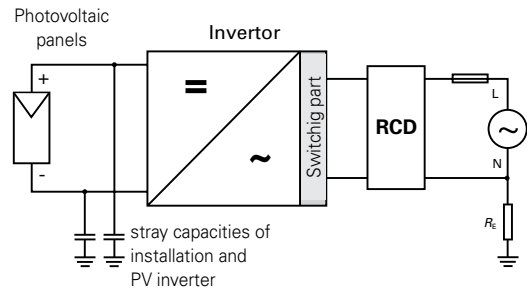

Fig. 89 Use of RCD type B on alternating current side

What type of RCD should be selected?

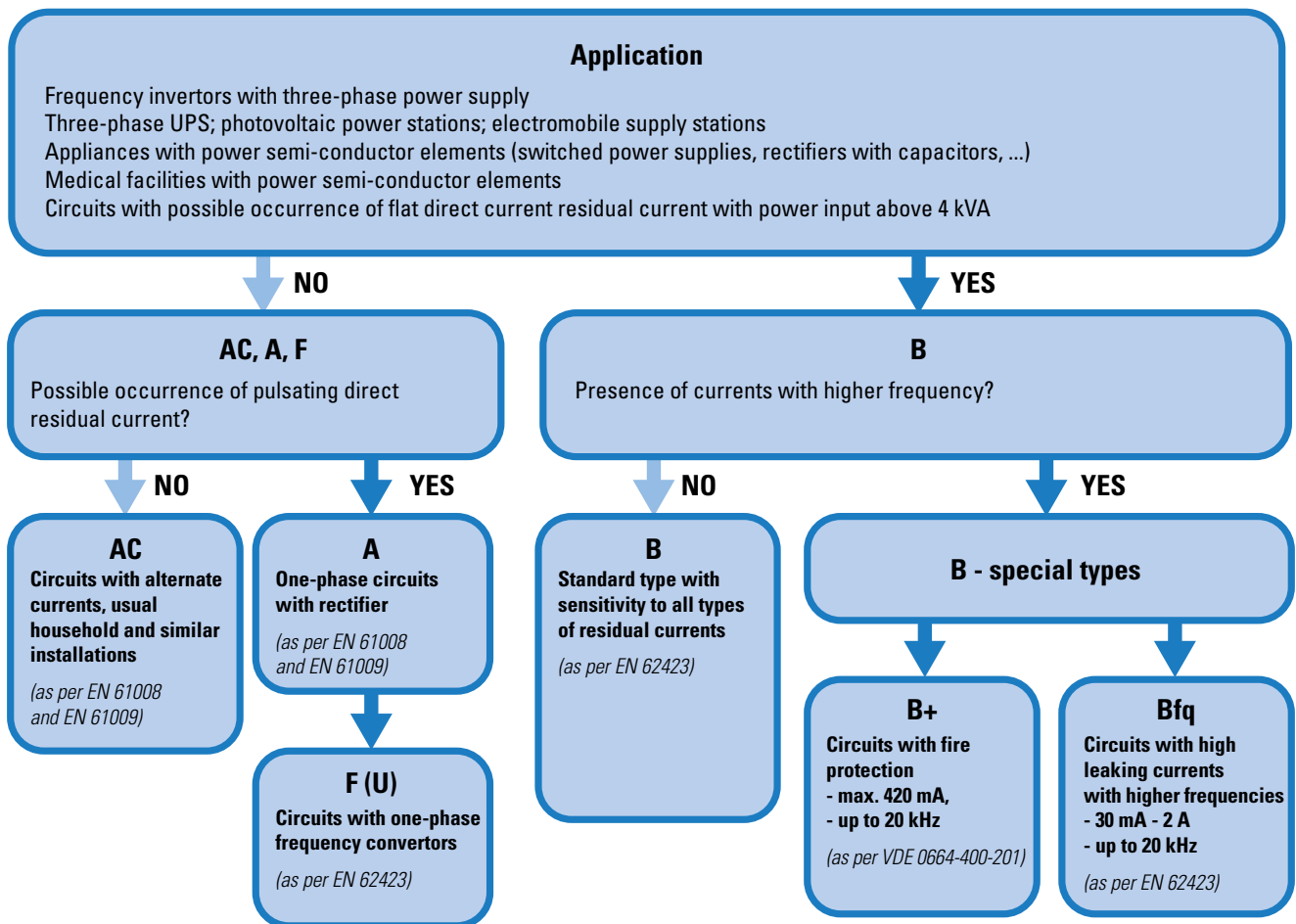

Fig. 90 Help for selection of types of RCDs

10. Problem solving

There are two kinds of problems with incorrect behaviour of RCDs: either the RCD fails to trip or trips when it is not supposed to.

A) Non-functioning RCD

Defect	Solution
Failure of RCD	Measurement by verification tool and possible exchange is necessary
A higher value of residual current is necessary for tripping but at a second measurement, the RCD already works correctly	A typical fault resulting from failure to carry out regular functional testing by test button; exchange necessary
Non-functioning test button	Verify insulation status of N and PE conductors, and according to situation, exchange the device (usually burnt resistor due to connection errors)
Device does not respond to residual currents due to high direct residual currents	Impact of power electronic devices located in vicinity must be verified and suitable version should be applied (type B+, Bfq)
Welding or adhesion of RCCB contacts	Impact of overcurrents, necessary check of preliminary protection; replace

B) Unwanted tripping of RCDs:

Most frequent causes are:

- incorrect selectivity;
- constant leakage currents in installations;
- high leakage currents in interference filters in circuits with higher frequencies;
- impact of surge voltage protectors;
- switching surge overvoltage;
- connection errors.

10.1 Connection errors

The main causes of unwanted tripping:

- connection of PE and N conductors together,
- connecting the N conductor circuit to another N block,
- interconnection of individual N wires to the common blocks N,
- wrong orientation of working wires,
- too large an installation after the RCD - the influence of leakage current.

Connection of PE and N conductors after the RCD (Figure 91) is the most frequent cause of unwanted tripping. This defect is mostly identified when activating any appliance, followed by immediate tripping. Verification of separation of both conductors is easy, carried out by measuring insulation status when the RCD is off, as depicted on Figure 92.

An accompanying symptom of connected PE and N conductors is also the fact that when pushing the TEST button, the corresponding RCD cannot be tripped. If anyone tries to make the device trip by prolonged long pushing of the test button for several seconds, the result will be burnt resistance multiplier of the verification circuit inside the RCD because the resistance multiplier is only designed for short tripping times. The cause of this seemingly inexplicable symptom is the fact that connecting the PE and N conductors after the residual current device creates a shorted coil between N and PE conductors, making part of the test current flow outside the summation current transformer. The remaining portion of the test current is mostly insufficient

for device tripping. However, there can still be cases when after connecting PE and N conductors after the RCD, pushing the test button will still cause the device to trip. This will occur with a relatively high impedance of the created shorted coil before significant desensitization of the RCD.

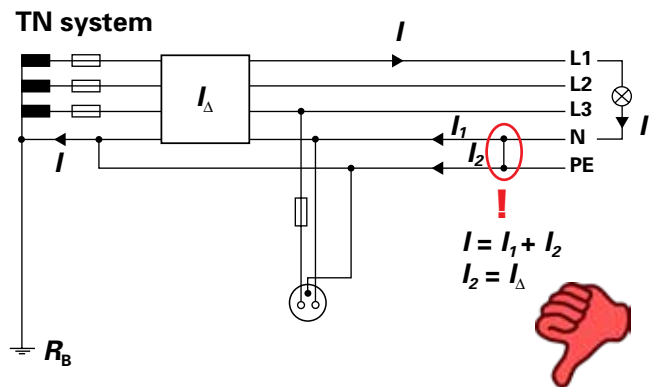

RCD will trip immediately after appliance power up!

Fig. 91 Impermissible connected PE and N conductors after the RCD



Fig. 92 Check of separation of PE and N conductors after a tripped RCD

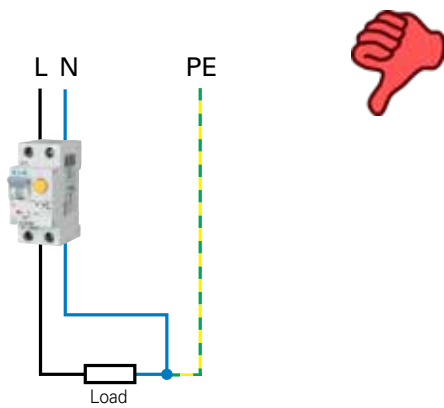

RCD will trip immediately after appliance power up!

Fig. 93 Wrong connection of PE and N conductors

Figures 93, 94 describe faulty wiring that can occur due to limited space within consumer units. Terminal boxes for neutral wires used for the circuits after the RCD are often located close to the input of the RCD and wiring of the neutral conductor is done in the shortest way. These errors can be easily prevented by systematic labeling the live and neutral wires during installation.

Figure 96 shows incorrect connection of neutral wires in switchboards, typically caused inadvertently. After activation of an appliance with higher power input, one or more RCDs will trip because the currents will split by impedance of the various circuits and the resulting current differences will be evaluated as residual currents. Another example of incorrect connection is depicted on Fig. 96. When merging outlets behind one RCD, the following rule must be met: „how many RCDs, so same number of neutral blocks“.

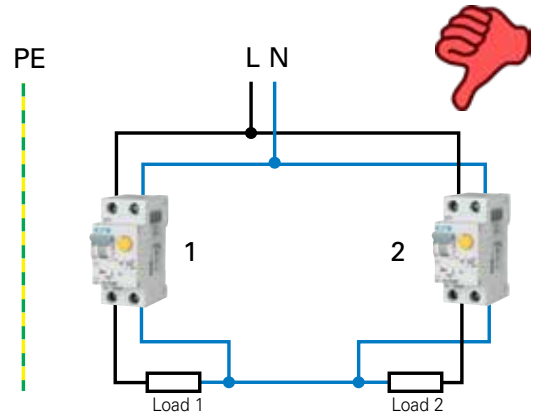

Working conductors after various RCDs must not be interconnected!

Fig. 94 Parallel connection of two RCDs

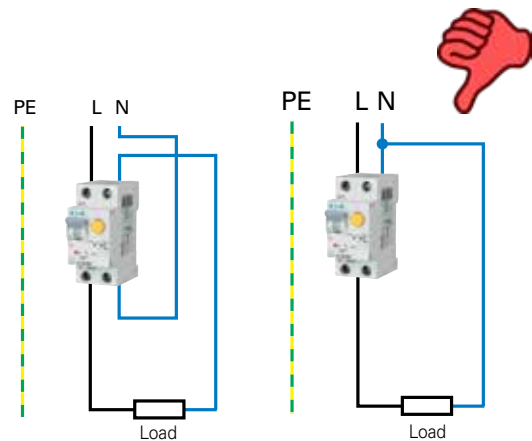
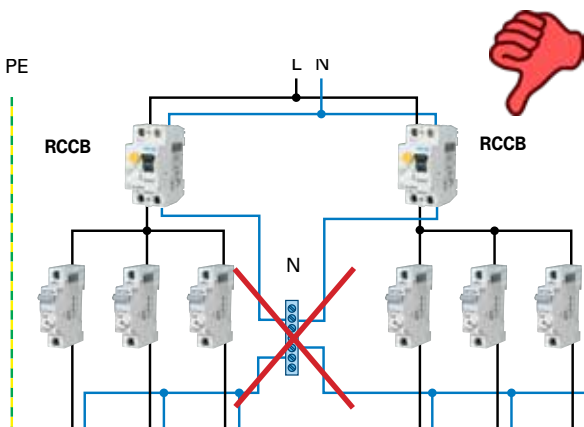
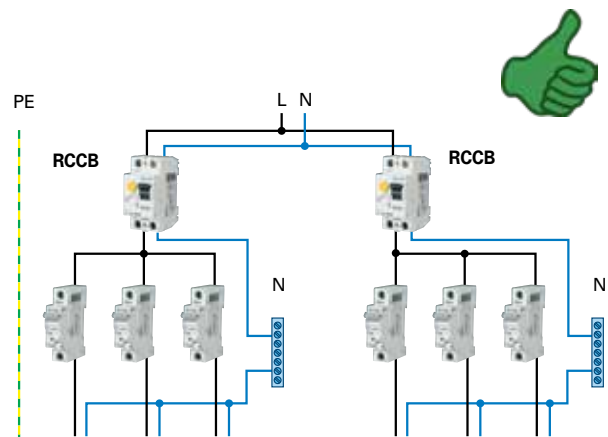

Fig. 95 Incorrect connection of neutral conductor



One of RCD will trip immediately after appliance power up!

Fig. 96 Use of independent neutral blocks for the various circuits after RCDs



10.2 Automatic and remote activation

Figure 97 describes possibilities of providing the best possible resistance to unwanted tripping of RCDs. Non-delayed types have the lowest endurance (resistance to surge currents up to 250 A). Considerably higher is endurance of delayed types (endurance of 3 or 5 kA) with numbers of unwanted trippings within the range of units of percent as compared to non-delayed types.

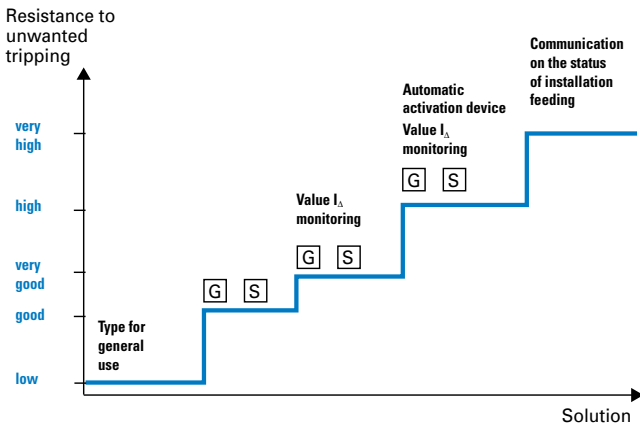

Fig. 97 Resistance to unwanted tripping of RCDs

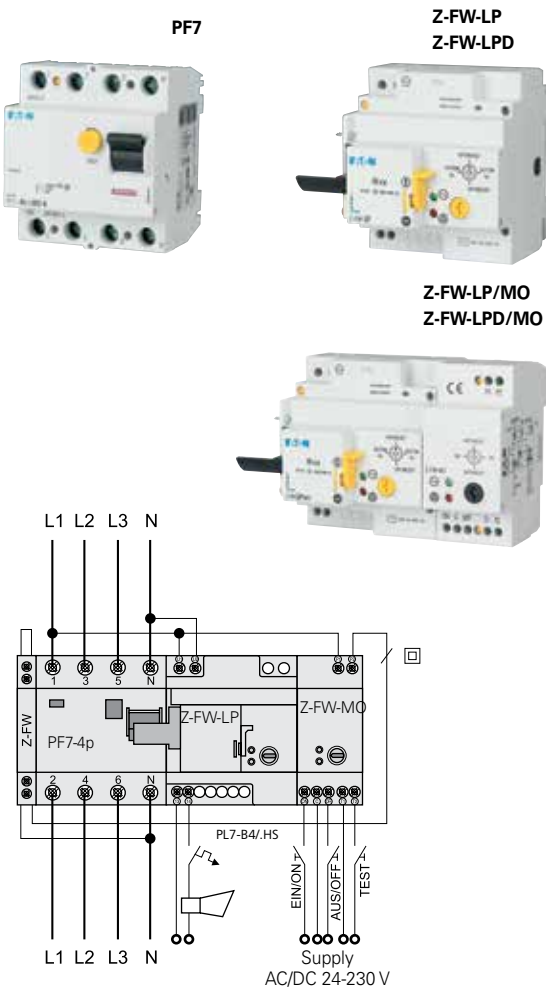

Fig. 98: Devices for remote and automatic activation of RCDs

For the remaining cases when even delayed types do not help or there are no operating personnel (telecommunication transmitters, petrol stations etc.), devices for remote activation come in. Supply to a remote actuator can be from a supply network or a backup supply source (UPS, battery). Users may select the number of repeated attempts and if the last attempt also fails, the device will send out signal to operating personnel indicating a fault in the installation. The price of devices allowing automatic activation is a one-off investment but will save costs of repeated interventions and reduce equipment downtimes.

9.6 Lean connectivity in industrial applications

RCDs are an important component for reducing downtime, but machine builders and installers can increase uptime further and make savings of up to 30% by integrating them within a Lean Automation environment. For example, devices such as MCBs, RCCBs and RCBOs can be easily and quickly connected to the SmartWire-DT line through Eaton's SmartWire-DT MCB module. This makes additional I/O level and wiring redundant, enabling machine builders to reduce installation time and costs.

Through using this system, the status (on, off, tripped) of the protective devices is made available within the control or monitoring system of the machine or the power distribution network. This supports the service and maintenance teams continuously with information about the system, helping them to react immediately to problems and to keep the system downtime to a minimum.

Example: Savings in every step of the life cycle

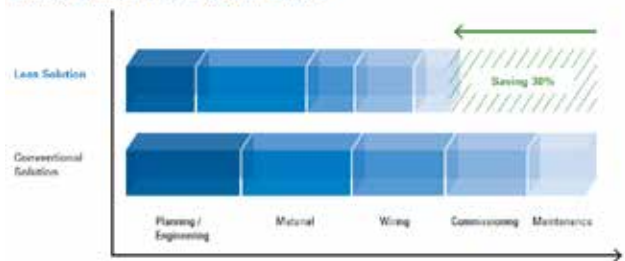

Fig. 99 Savings accruing from migration to a lean solution



Fig. 100 Downtime can be reduced further by integrating RCDs with Eaton's SmartWire-DT line

Abbreviations

For reference purposes we also specify additional abbreviations more and more frequently encountered in foreign technical documentation and in new electrotechnical regulations:

ACB - Air Circuit Breaker

AFCI - Arc Fault Circuit Interrupter (USA)

AFDD - Arc Fault Detection Device (Europe)

CRB - Current Breaker incorporated with Residual current device

EGFPD - Equipment Ground-Fault Protection Devices (GB)

GFCI - Ground Fault Current Interruptor (USA) = RCD (IEC)

IMD - Insulation Monitoring Device

MCBs - Miniature Circuit Breakers

MCCBs - Moulded Case Circuit Breakers

MRCD - Modular Residual Current Device

OCD, OCPD - Over Current Protective Device

PRCD - Portable Residual Current Device

RCD - Residual Current Device

RCBO - Residual Current operated Circuit Breakers with integral Overcurrent protection for household and similar uses

RCCB - Residual Current operated Circuit Breakers without integral overcurrent protection for household and similar uses

RCM - Residual Current Monitors for household and similar uses

SPD - Surge Protective Device

SRCD - Socket-outlets Residual Current protective Device

Graphic symbols

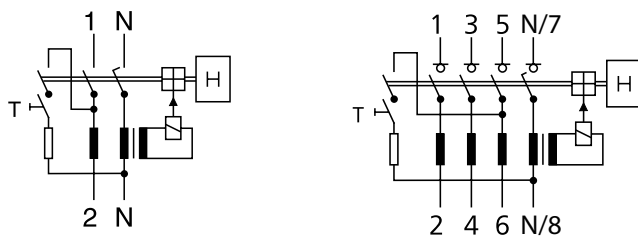
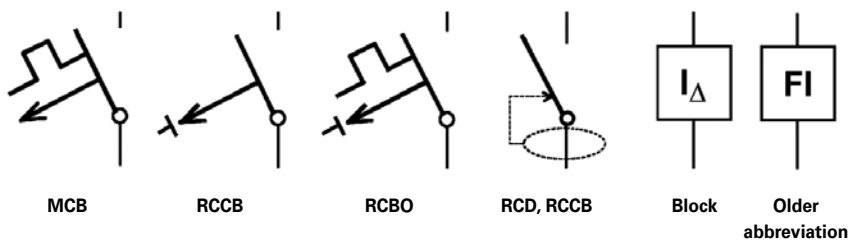

Application of RCD				
According to IEC/ mod HD	<ul style="list-style-type: none"> as protection against electric shock: AP - Additional Protection AD - Automatic Disconnection (at fault) as fire protection: F - Fire Protection 			
$I_{\Delta n}$	$\leq 30 \text{ mA}$	$\leq 100 \text{ mA}$	$\leq 300 \text{ mA}$	$\leq 500 \text{ mA}$
60364-4-41 Protection against electric shock	AP - sockets for ordinary persons $\leq 20 \text{ A}$; outdoor sockets ≤ 32	AD - can be used for AD next to devices for protection against overcurrent (OCPD); must be used for AD, if they do not comply with AD OCPD (circuit breakers or fuses)		
60364-4-42 60364-4-41 Protection against heat	F - overhead heating circuits		F - TN and TT end circuits for areas with fire hazards	
60364-7-701 Areas with a bath tub or a shower	AP - the entire low-voltage installation in a room with a bath tub or a shower			
60364-7-702 Swimming pools and other tanks	AD - for fountains AP - for pools in zone 2 and for the lines the zone 0, 1, 2			
60364-7-704 Construction and demolition sites	AP - Socket circuits $\leq 32 \text{ A}$			Socket circuits $> 32 \text{ A}$
60364-7-705 Agriculture and horticulture	AP - Socket circuits $\leq 32 \text{ A}$	Socket circuits $> 32 \text{ A}$	AD and F - Circuits other than socket circuits ($\leq 32 \text{ A}$ and $> 32 \text{ A}$)	
60364-7-706 Limited conductive areas	AP - supply to a mounted class II device			
60364-7-708 Mobile home parking lot	Single circuit breaker per one socket outlet			
60364-7-709 ports etc.	Each socket outlet, each end circuit to connect a houseboat			
60364-7-710 Medical facilities	$\leq 32 \text{ A}$ socket circuits - for medical facilities: group 1; in group 2 for circuits: - to move the operating table, - supplying X-ray devices, - to supply power to devices over 5 kVA - for powering devices with non-critical functions			
60364-7-711 Exhibitions, shows and stands	$\leq 32 \text{ A}$ socket circuits and terminal circuits (except for emergency lighting)		Power supply cables of temporary wiring systems	
60364-7-714 Outdoor lighting installations	Built-in lighting in phone booths, bus stops, etc.			
60364-7-717 Mobile or transportable units	When connected to a fixed electrical installation and as a complementary measure to the electrical department and for sockets for appliances outside the unit			
60364-7-721 Caravans, and mobile homes	AP - to be used as an supplementary measure for AD - see the HD 60364-4-41			
60364-7-722 Power supply of electric vehicles	Each connection point			
60364-7-740 Stands in amusement parks	End circuits for lighting, sockets $\leq 32 \text{ A}$, power cord devices $\leq 32 \text{ A}$		Electrical installation of each temporary structure	
60364-7-753 Heating cables and systems	Circuits supplying heating units			

Tab. 11 Examples of application of RCDs

Literature

- [1] Biegelmeier G.: Liber amicorum – liber inimicis, Wien, ESF, 2000
- [2] Biegelmeier G.: Schutz gegen elektrischen Schlag: Beurteilung der Grenzkrisiken – Wertigkeitsvergleiche, Wien, ESF, 2001
- [3] Biegelmeier G.: Wirkung des elektrischen Stromes auf den menschlichen Körper, Film, Wien, 1980
(<https://www.youtube.com/watch?v=08r27LnLHCM>)
- [4] Mörx A.: Die schutztechnische Funktion von Fehlerstrom-Schutzeinrichtungen in genullten Niederspannungsanlagen, DIAM consult, Wien 2011
- [5] Štěpán F.: Proudové chrániče (RCDs), IN-EL Praha, 2015
- [6] Genowitz P.L.: Protecting man and machine against demaging residual currents, Eaton, 2015
- [7] xEffect Catalogue, Eaton 2015
- [8] ZVEI – Zentral Elektrotechnik und Elektroindustrie e.v., Germany (www.zvei.org)
- [9] IEC/TS 60479-1: (2013) Effect of current on human beings and livestock – Part1: General aspects
- [10] IEC/TS 60479-2: (2014) Effect of current on human beings and livestock – Part 2: Special aspects
- [11] IEC 61140 ed. 2: (2003) – Protection against electric shock – Common aspects for intallation and equipment
- [12] IEC 60364-1, Low-voltage electrical installations - Part 1: Fundamental principles, assessment of general characteristics, definitions (HD 60364-1)
- [13] IEC 60364-4-41 (2005), Low-voltage electrical installations - Part 4-41: Protection for safety - Protection against electric shock (HD 60364-4-41)
- [14] IEC 60364-5-53 (2015) Electrical installations of buildings - Part 5: Selection and erection of electrical equipment - Chapter 53: Switchgear and controlgear
- [15] IEC 60364-6 (2006), Verification
- [16] IEC 60364-7-xx, Electrical installations of buildings - Part7: Requirements for special installations and locations
- [17] IEC 61008-1 Residual current operated circuit-breakers without integral overcurrent protection for household and similar uses (RCCBs) - Part 1: General rules
- [18] IEC 61009-1 Residual current operated circuit-breakers with integral overcurrent protection for household and similar uses (RCBOs) - Part 1: General rules
- [19] IEC 62423 ed. 2:(2013) Residual current operated circuit-breakers with integral overcurrent protection and without integral overcurrent protection for household and similar use type F and B
- [20] IEC 61543 (1995) Residual current-operated protective devices (RCDs) for household and similar use – Electromagnetic compatibility
- [21] IEC 60947-2 (2006): Low-voltage switchgear and controlgear - Part 2: Circuit-breakers (EN 60947-2:2006)
- [22] IEC TR 62350 (2006): Guidance for the correct use of residual curren-operated protective devices (RCDs) for household and similar use
- [23] IEC 50178 (1996), Electronic equipment for use in power installations
- [24] IEC 62606, General requirements for arc fault detection devices

Eaton's electrical business is a global leader with deep regional application expertise in power distribution and circuit protection; power quality, backup power and energy storage; control and automation; life safety and security; structural solutions; and harsh and hazardous environment solutions. Through end-to-end services, channel and an integrated digital platform & insights Eaton is powering what matters across industries and around the world, helping customers solve their most critical electrical power management challenges.

For more information, visit [Eaton.com](https://www.eaton.com).



Eaton Industries (Austria) GmbH
Schedygasse 42
1210 Vienna
Austria

Eaton
EMEA Headquarters
Route de la Longeraie 7
1110 Morges, Switzerland

© 2017 Eaton
All Rights Reserved
Publication No. BR019003EN
Article number 188249-MK
September 2025

Changes to the products, to the information contained in this document, and to prices are reserved; as are errors and omissions. Only order confirmations and technical documentation by Eaton is binding. Photos and pictures also do not warrant a specific layout or functionality. Their use in whatever form is subject to prior approval by Eaton. The same applies to trademarks (especially Eaton, Moeller, and Cutler-Hammer). The Terms and Conditions of Eaton apply, as referenced on Eaton Internet pages and Eaton order confirmations.

Eaton is a registered trademark.

All other trademarks are property of their respective owners.

Follow us on social media to get the latest product and support information.

