

FOR RECYCLING PURPOSES ONLY

Disassembly Instructions

OT Plus Switch-Disconnectors
OT(C)16...63G1-

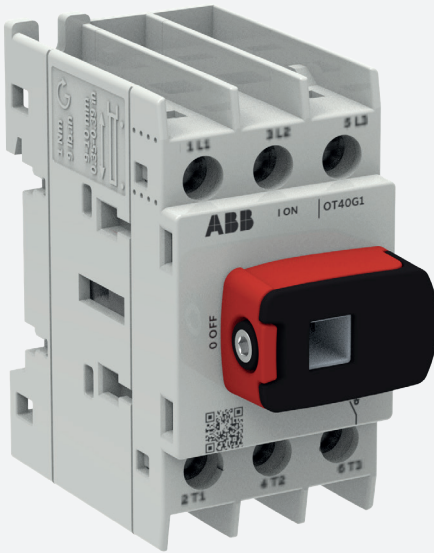

Table of contents

003	Important information
004–008	Disassembly of the switch-disconnector
009-010	Component list
011	Recycling information in accordance with the WEEE

Important information

This document shows the disassembly process of OT Plus OT(C)16...63G1-switch-disconnectors. Accessories, such as shafts, shrouds, additional poles and auxiliary contacts are not included. **Note! This document is for recycling purposes only.**

This document uses OT40G1-3BS version as a reference product, and it covers other versions of OT Plus OT(C)16...63G1-switch-disconnectors with few differences to be taken into account. These differences include terminal type, number of poles and pole configuration. Other differences between switch-disconnectors may result from accessories, including shafts, handles, phase barriers, shrouds, connection bars, auxiliary contacts, mechanical lugs and interlocks.

Safety Notes

Before starting the disassembly process it is mandatory to put the switch-disconnector in open position.

Disassembly of switch-disconnectors must be performed by qualified and skilled personnel in the electrical field (IEV 195-04-01: person with relevant education and experience to enable him or her to perceive risks and to avoid hazards which electricity can create) and having a detailed knowledge of switch-disconnectors.

Disassembly must be done in an ergonomic workspace which can ensure the protection of the person doing the disassembling.

Applicable national legislation and international standards in force at the time of the disassembly of the switch-disconnectors

must be taken into account in addition to the prescriptions illustrated in this document.

ABB declines any responsibility for injury to people or damage to property resulting from a failure to comply with the instructions set out in this document and with any applicable safety standard.

Personal Protective Equipment (PPE)

When doing the disassembling following safety Personal Protective Equipment (PPE) must be worn:



Tools

The disassembly process requires the use of tools (e.g. screwdriver, torx key, pliers). Tools to be used are specified inside each phase of the disassembly process.

Disassembly process

For each phase of the disassembly process the following information is provided:

- Tools to be used
- Pictures showing actions to be performed
- In case of potential hazards this signal is reported:





Disassembly of the switch-disconnector

1

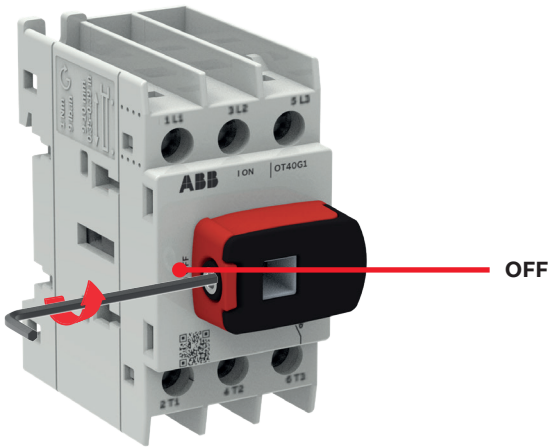

-
- Tools**
- Hex key
- 
- 2.5 mm

2

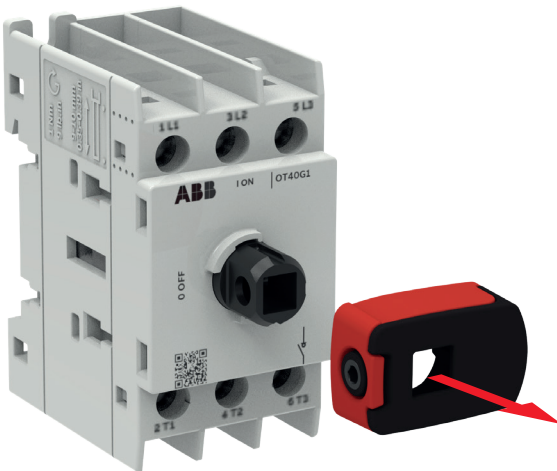

3

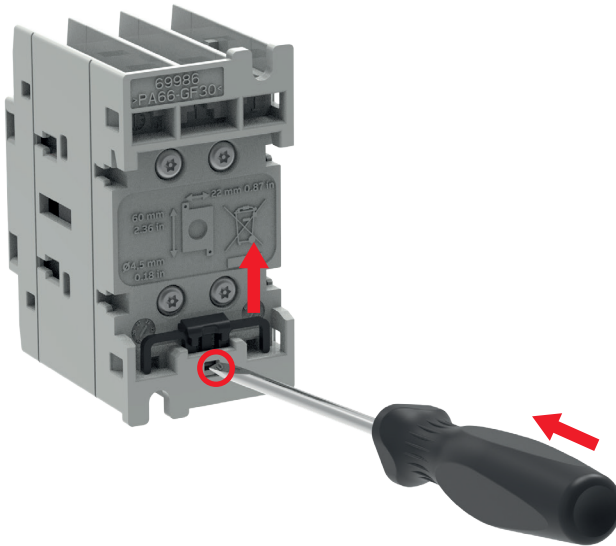

—
Tools

Flat screwdriver



4

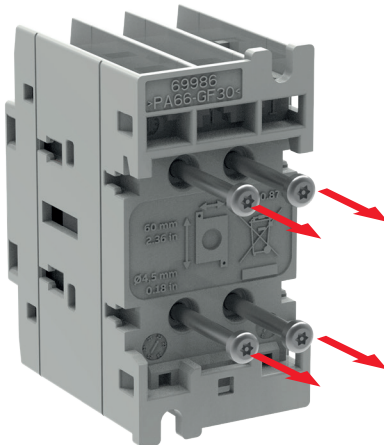

—
Tools

Torx tamper-proof

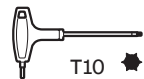

6

DISASSEMBLY INSTRUCTIONS

5

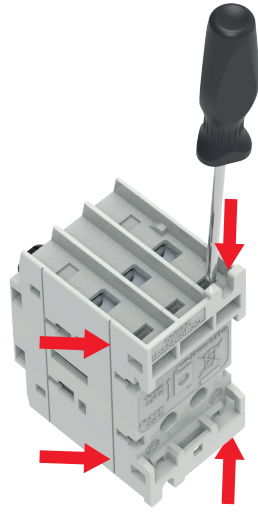

6

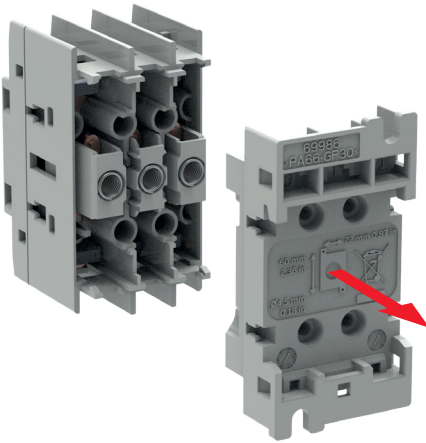

7

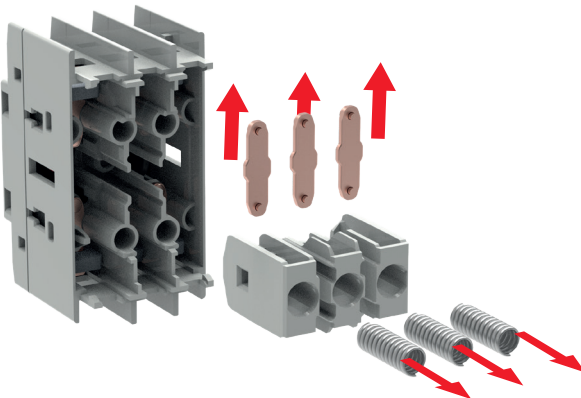

8

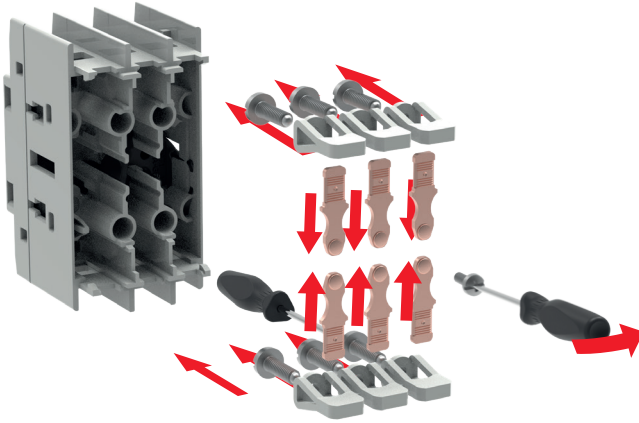

9

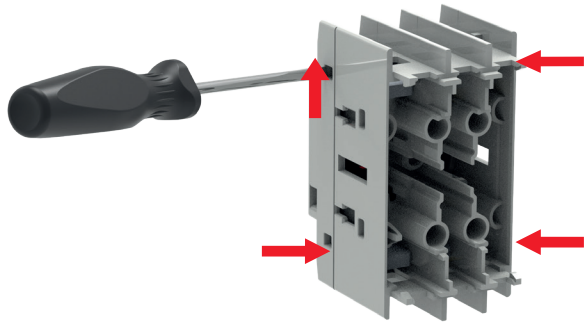

10

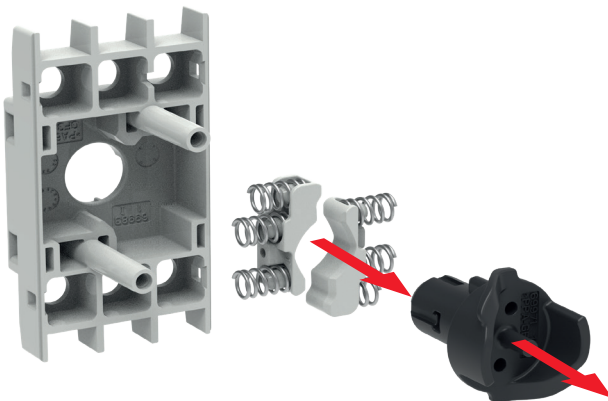

11

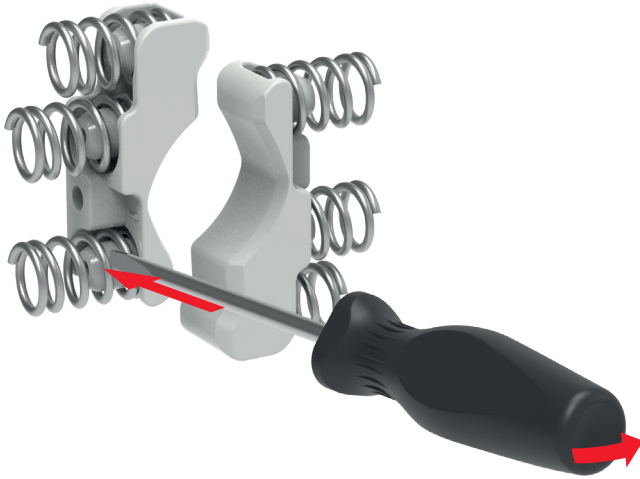

—
Tools
Flat screwdriver



12

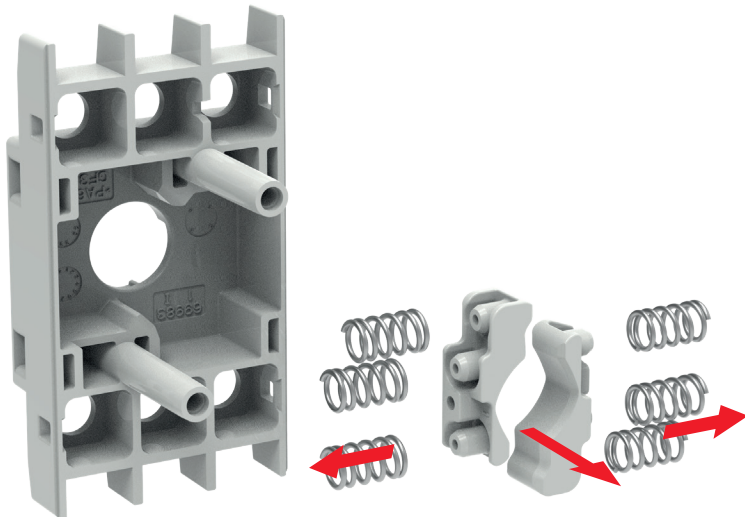

Component list

Switch-disconnector OT(C)16...63G1-

Component name	Quantity	Material(s)	Weight (g/pc)
Mechanism cover	1-2	Polyamide	12-26
Upper frame	1-2	Polyamide	27-37
Shaft	1-2	Polyamide	4.5
Rhythm piece	2-4	Polyoxymethylene (POM)	1
Compression spring	6-12	Steel	0.5
Tunnel terminal	6-16	Steel	2.5
Fixed contact	4-8	Copper	1
Tunnel terminal screw	6-16	Steel	1
Contact tip	12-32	Silver nickel alloy	0.1
Spring terminal assembly****	6-16	Copper, Steel, Polyamide	2.6
Bridge	1-2	Polyamide	5.5-8
Offset spacer**	1-2	Polyamide	0.5
Adjusting piece**	1-2	Polyamide	0.2
Late break spring**	1-2	Steel	0.1
Moving contact	3-8	Copper	1
Compression spring	3-8	Chromium steel	1
Lower frame	1-2	Polyamide	19-23
Screw	4-12	Steel	1
Din lock*	1-4	Polyamide	1
Handle*	1		5
Lock piece***	2	Polyamide	0.2
Lock piece***	2	Polyamide	0.2

Handle*

Component name	Quantity	Material(s)	Weight (g/pc)
Handle base*	1	Polyamide	3
Locking piece*	1	Polyamide	1.5
Hexag. socket head screw*	1	Steel	1

*Only in OT(C)16...63G1-3BS and OT(C)16...63G1-4BSN2

**Only in OT(C)16...63G1-4BSN2 and OT(C)16...63G1-4DSN2

***Only in OT16...63G1-6BS, OT16..63G1-8BS and OTC16...63-G1-

****Only in OT(C)16...40G1-Q_

Recycling information in accordance with the WEEE

The product is marked with the wheelie bin symbol. It indicates that at the end of life the product should enter the recycling system.

You should dispose of it separately at an appropriate collection point and not place it in the normal waste stream.

The figure below shows the wheelie bin symbol indicating separate collection for electrical and electronic equipment (EEE).



The horizontal bar underneath the crossed-out wheelie bin indicates that the equipment has been manufactured after the Directive came into force in 2005.

The wheelie bin symbol is added to the type designation label of the product since 2017.



Contact us

ABB Oy

Muottitie 2A 65320

Vaasa, Finland

abb.com/lowvoltage