

Data Sheet | Item Number: 891-8994/116-201

pre-assembled connecting cable; Eca; Socket/open-ended; 4-pole; Cod. A;
H05Z1Z1-F 4G 1.5 mm²; 2 m; 1,50 mm²; black

<https://www.wago.com/891-8994/116-201>

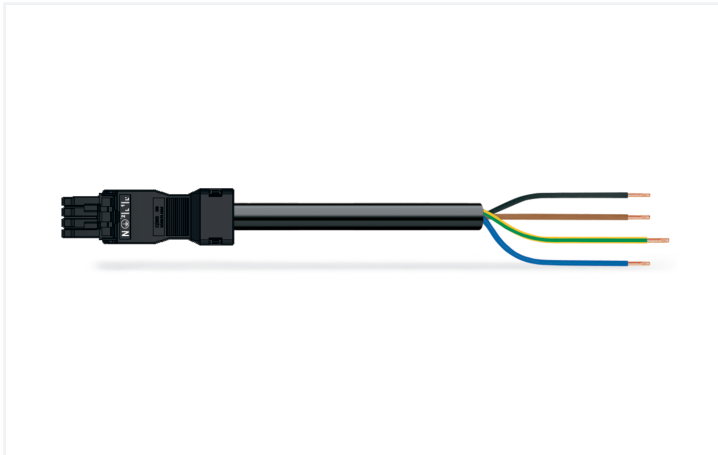

Color: ■ black

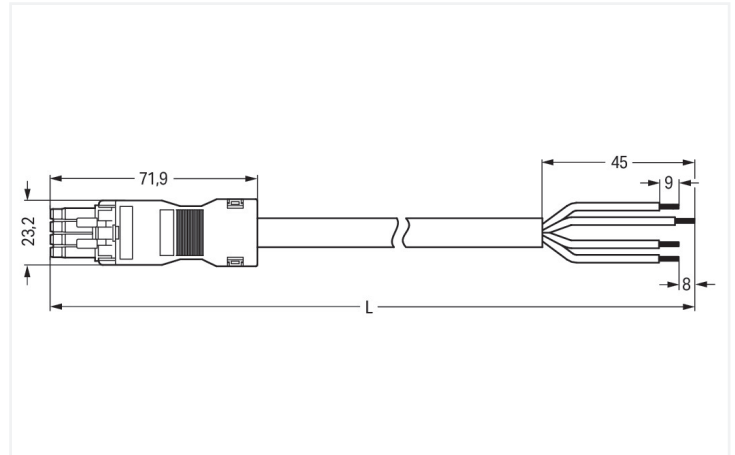

Dimensions in mm

Cable assembly WINSTA® MINI with strain relief

The WINSTA® MINI cable assembly with protection against mismatching provides the foundation for installation of fine-stranded and solid conductors. Whether on PCBs, in control cabinets or for connecting lights – pluggable installation connectors from WAGO allow you to make connections according to various requirements in seconds. The mechanical coding and color coding of the pluggable installation connector ensure error-free installation of the individual components – including protection against mismatching. The pluggable installation connector offers protection against contact with tools or wires if they are smaller than 1 mm in accordance with protection type IP40. The WINSTA® MINI pluggable installation connector with A coding in black or white is usually used for general mains applications in power distribution. WINSTA® MINI satisfies the demand for miniaturisation. Our smallest pluggable connection system is primarily suited for lights, for example, since due to LED technology, these offer significantly less space for the connection technology. According to the European CPR, the fire class of the cables used for construction is decisive for building safety as well. For buildings with average safety requirements, cable assemblies with fire class E are suitable. In the manufacturing of this cable assembly, halogens were deliberately omitted. This is an important contribution to environmental protection.

Fast, error-free assembly thanks to cable assemblies from WAGO

The cable assembly is equipped with a socket and a free end. The WINSTA® Pluggable Connection System is perfectly tailored to the very strict requirements of building installation. It makes electrical installation pluggable, and therefore faster, even more reliable, and error-free. Using this pre-assembled system reduces time spent on assembly and installation errors at the construction site. Enjoy the benefits of the pluggable version of our maintenance-free spring pressure connection technology too! Plan your installation with with protection type IP40 from WAGO.

- effective protection against mismatching
- consistent IP40 protection
- with A coding for a great number of uses
- ready for immediate use
- fast, secure installation

Notes

Note Cables with a different fire class can be found in the eShop.

Electrical data

Ratings per	IEC/EN 60664-1			General information	
Overvoltage category	III	III	II	Note on contact resistance	approx. 1 mΩ of contact resistance approx. 0.25 mΩ contact transition plug/ socket
Pollution degree	3	2	2		
Nominal voltage	400 V	-	-		
Rated impulse withstand voltage	6 kV	-	-		
Rated current	16 A	-	-		

Connection Data

Total number of potentials	4	Connection 1	
PE function	Preceding PE contact	Strip length	9 mm / 0.35 inches
Conductor preparation	ultrasonically tip-bonded	Pole number	4
		Wire cross-section	1.5 mm ²
		Strip length (outer insulation)	45 mm
		Connection type	Socket - free end

Physical data

Pin spacing	4.4 mm / 0.173 inches
Width	23.2 mm / 0.913 inches
Height	16 mm / 0.63 inches
Total length	2 m

Mechanical data

Use	General mains applications
Coding	A
Variable coding	No
Marking	N ⊕ 2/L 1/L'
Potential marking	N ⊕ 2/L 1/L'
Mating force of a plug-in connection	approx. 20 ... 70 N (depending on pole number)
Retention force of a plug-in connection	when locked: > 80N
Unmating force of a plug-in connection	when unlocked: approx. 20 ... 70 N (depending on pole number)
Number of mating cycles	200, without resistive load
Connection type	Socket - free end
Type of pre-assembled cable	Connecting cable
Cable type	H05Z1Z1-F 4G1.5
Protection type	IP40

Plug-in connection

Mismating protection	Yes
Note on mismating protection	All WINSTA® components are 100% protected against mismating when: a.) plugging different numbers of poles b.) plugging while rotated 180 c.) plugging while laterally staggered d.) plugging one pole
Locking lever	Can be retrofitted
Locking of plug-in connection	Locking lever
Note on locking system	All connectors for mounted installations (snap-in versions for lighting fixtures or devices, all types of PCB and distribution connectors) are factory-equipped with locking levers to ensure plugs and sockets are securely locked. Additional locking levers are only required for flying leads (plug/socket).

Material data

Note (material data)	Information on material specifications can be found here
Color	black
Insulation material (main housing)	Polyamide (PA66)
Fire class per EN 50575	E _{ca}
Contact material	Copper or copper alloy; surface-treated
Contact Plating	Tin
Fire load	59.915 MJ
Connector color	black
Strain relief color	black
Sheathed cable color	black
Printing color of sheathed cable	white
Halogen-free	Yes
Silicon-free	Yes
Sheath material	Halogen-free
Rubber cable	No
Weight	245.6 g
Copper weight of the raw cable	0.058 kg/m

Environmental requirements

Processing temperature	-5 ... +40 °C
Continuous operating temperature	-35 ... +85 °C
Note on continuous operating temperature	Cable for temperatures ≤ 70 °C (including halogen-free) Insulating parts for temperatures ≤ 105 °C

Commercial data

PU (SPU)	1 pcs
Packaging type	unpacked
Country of origin	PL
GTIN	4055143405072
Customs tariff number	85444290900

Product Classification

UNSPSC	26121629
eCl@ss 10.0	27-44-06-04
eCl@ss 9.0	27-44-06-04
ETIM 9.0	EC002587
ETIM 10.0	EC002587
ECCN	NO US CLASSIFICATION

Environmental Product Compliance

RoHS Compliance Status	Compliant, No Exemption
------------------------	-------------------------

Approvals / Certificates

General approvals



Approval	Standard	Certificate Name
CCA DEKRA Certification B.V.	EN 61535	NTR NL-7971
KEMA/KEUR DEKRA Certification B.V.	EN 61535	71-123232

Downloads

Environmental Product Compliance

Compliance Search

Environmental Product Compliance 891-8994/116-201	↓
--	-------------------

Documentation

Bid Text

891-8994/116-201	19.02.2019	xml 3.01 KB	↓
891-8994/116-201	01.12.2014	doc 25.00 KB	↓

CAD/CAE-Data

CAE data

EPLAN Data Portal 891-8994/116-201	↓
WSCAD Universe 891-8994/116-201	↓

1 Compatible Products

1.1 Required Accessories

1.1.1 Locking system

1.1.1.1 Locking system



Item No.: 890-111

Locking lever; for flying leads; for tool operation; black

Item No.: 890-131

Locking lever; for flying leads; for tool operation; white

Item No.: 890-101

Locking lever; for manual operation; black

Item No.: 890-121

Locking lever; for manual operation; white

1.2 Optional Accessories

1.2.1 Cover

1.2.1.1 Cover



Item No.: 897-2003

Protective cap; Type2; for sockets and plugs; PVC; red

1.2.2 Installation

1.2.2.1 Mounting accessories



Item No.: 890-310

Mounting carrier; 2- to 5-pole; for flying leads; black

Item No.: 890-311

Mounting carrier; 2- to 5-pole; for flying leads; white