

## Data Sheet | Item Number: 891-8992/116-102

pre-assembled connecting cable; Eca; Socket/open-ended; 2-pole; Cod. A;  
H05Z1Z1-F 2 x 1,50 mm<sup>2</sup>; 1 m; 1,50 mm<sup>2</sup>; white

<https://www.wago.com/891-8992/116-102>

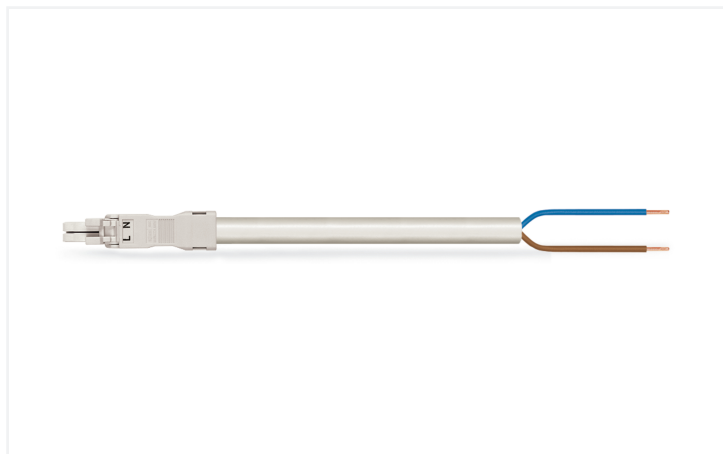

Color: ■ white

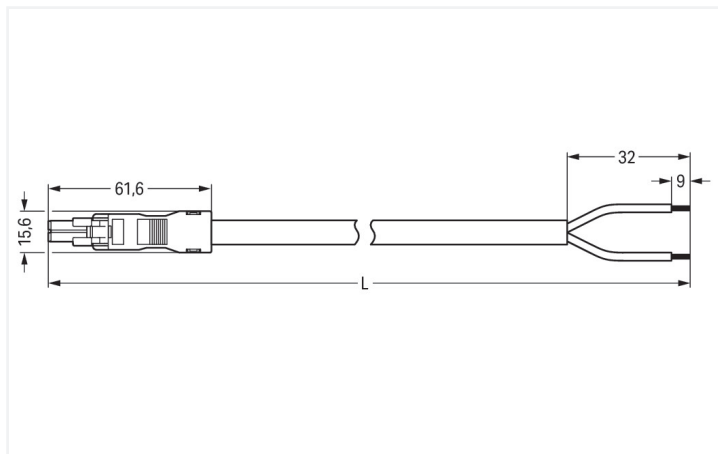

Dimensions in mm

### Cable assembly WINSTA® MINI 2-pole

Use effective pluggable connections instead of laborious screw connections: With the WINSTA® MINI cable assembly with protection type IP40. Whether on PCBs, in control cabinets or for connecting lights – pluggable installation connectors from WAGO allow you to make connections according to various requirements in seconds. For greater security in electrical installations, the pluggable installation connector is provided with mechanical protection against mismatching. The pluggable installation connector is protected in accordance with protection type IP40. Users' hands and tools will never come into contact with live elements. The WINSTA® MINI pluggable installation connector with A coding in white or black is usually used for general mains applications in power distribution. WINSTA® MINI satisfies the demand for miniaturisation. Our smallest pluggable connection system is especially suitable for lights, for instance, since due to LED technology, these offer much less space for the connection technology. Building safety must be ensured at all times, even after the electrical installation stage. The required safety requirements in connection with EU CPR are met by this product through fire class E. In the production of this cable assembly, we eliminated the use of halogen. That is an important contribution to environmental protection.

### Fast, secure pluggable connections – cable assemblies from WAGO

A socket and a free end are available. WINSTA® is the pluggable connection system that is optimally tailored to the strict requirements of electrical installation. It offers fast, secure and, above all, error-free installation of components and cables. Now you can also cut installation costs without compromising quality and safety: with fire class E reduces the need for servicing and prevents unnecessary downtime.

- effective protection against mismatching
- consistent IP40 protection
- with A coding for use in a large number of general mains applications
- ready to install and use immediately
- rapid, structured electrical installation

### Notes

Note

Cables with a different fire class can be found in the eShop.

## Electrical data

Ratings per	IEC/EN 60664-1		
Overvoltage category	III	III	II
Pollution degree	3	2	2
Nominal voltage	250 V	-	-
Rated impulse withstand voltage	4 kV	-	-
Rated current	16 A	-	-

## General information

Note on contact resistance	approx. 1 mΩ of contact resistance approx. 0.25 mΩ contact transition plug/ socket
----------------------------	--

## Connection Data

Total number of potentials	2
Conductor preparation	ultrasonically tip-bonded

## Connection 1

Strip length	9 mm / 0.35 inches
Pole number	2
Wire cross-section	1.5 mm <sup>2</sup>
Strip length (outer insulation)	32 mm
Connection type	Socket - free end

## Physical data

Pin spacing	4.4 mm / 0.173 inches
Width	15.6 mm / 0.614 inches
Height	13.2 mm / 0.52 inches
Total length	1 m

## Mechanical data

Use	General mains applications
Coding	A
Variable coding	No
Marking	L N
Potential marking	L N
Mating force of a plug-in connection	approx. 20 ... 70 N (depending on pole number)
Retention force of a plug-in connection	when locked: > 80N
Unmating force of a plug-in connection	when unlocked: approx. 20 ... 70 N (depending on pole number)
Number of mating cycles	200, without resistive load
Connection type	Socket - free end
Type of pre-assembled cable	Connecting cable
Cable type	H05Z1Z1-F 2x1.5
Protection type	IP40

## Plug-in connection

Mismating protection	Yes
Note on mismating protection	All <i>WINSTA</i> ® components are 100% protected against mismating when: a.) plugging different numbers of poles b.) plugging while rotated 180 c.) plugging while laterally staggered d.) plugging one pole
Locking lever	Can be retrofitted
Locking of plug-in connection	Locking lever
Note on locking system	All connectors for mounted installations (snap-in versions for lighting fixtures or devices, all types of PCB and distribution connectors) are factory-equipped with locking levers to ensure plugs and sockets are securely locked. Additional locking levers are only required for flying leads (plug/socket).

### Material data

Note (material data)	<a href="#">Information on material specifications can be found here</a>
Color	white
Insulation material (main housing)	Polyamide (PA66)
Fire class per EN 50575	E <sub>ca</sub>
Contact material	Copper or copper alloy; surface-treated
Contact Plating	Tin
Fire load	29.698 MJ
Connector color	white
Strain relief color	white
Sheathed cable color	white
Printing color of sheathed cable	black
Halogen-free	Yes
Silicon-free	Yes
Sheath material	Halogen-free
Rubber cable	No
Weight	83.5 g
Copper weight of the raw cable	0.029 kg/m

### Environmental requirements

Processing temperature	-5 ... +40 °C
Continuous operating temperature	-35 ... +85 °C
Note on continuous operating temperature	Cable for temperatures ≤ 70 °C (including halogen-free) Insulating parts for temperatures ≤ 105 °C

### Commercial data

PU (SPU)	1 pcs
Packaging type	unpacked
Country of origin	PL
GTIN	4055143392792
Customs tariff number	85444290900

### Product Classification

UNSPSC	26121629
eCl@ss 10.0	27-44-06-04
eCl@ss 9.0	27-44-06-04
ETIM 9.0	EC002587
ETIM 10.0	EC002587
ECCN	NO US CLASSIFICATION

### Environmental Product Compliance

RoHS Compliance Status	Compliant, No Exemption
------------------------	-------------------------

## Approvals / Certificates

### General approvals



Approval	Standard	Certificate Name
CCA DEKRA Certification B.V.	EN 61535	NTR NL-7971
KEMA/KEUR DEKRA Certification B.V.	EN 61535	71-123232

### Declarations of conformity and manufacturer's declarations

Approval	Standard	Certificate Name
EU-Declaration of Confor- mity WAGO GmbH & Co. KG	-	-
UK-Declaration of Confor- mity WAGO GmbH & Co. KG	-	-

## Downloads

### Environmental Product Compliance

#### Compliance Search

Environmental Product Compliance 891-8992/116-102	<a href="#">↓</a>
---	-------------------

## Documentation

### Bid Text

891-8992/116-102	19.02.2019	xml 3.02 KB	<a href="#">↓</a>
891-8992/116-102	21.11.2014	doc 24.50 KB	<a href="#">↓</a>

## CAD/CAE-Data

### CAE data

EPLAN Data Portal 891-8992/116-102	<a href="#">↓</a>
WSCAD Universe 891-8992/116-102	<a href="#">↓</a>

## 1 Compatible Products

### 1.1 Required Accessories

#### 1.1.1 Locking system

##### 1.1.1.1 Locking system



[Item No.: 890-111](#)  
Locking lever; for flying leads; for tool operation; black

[Item No.: 890-131](#)  
Locking lever; for flying leads; for tool operation; white

[Item No.: 890-101](#)  
Locking lever; for manual operation; black

[Item No.: 890-121](#)  
Locking lever; for manual operation; white

## 1.2 Optional Accessories

### 1.2.1 Cover

#### 1.2.1.1 Cover



**Item No.: 897-2001**

Protective cap; Type1; for sockets and plugs; PVC; red

## 1.2.2 Installation

### 1.2.2.1 Mounting accessories



**Item No.: 890-310**

Mounting carrier; 2- to 5-pole; for flying leads; black



**Item No.: 890-311**

Mounting carrier; 2- to 5-pole; for flying leads; white