

Data Sheet | Item Number: 891-8992/205-502

pre-assembled connecting cable; Eca; Plug/open-ended; 2-pole; Cod. A; H05VV-F 2 x 1.0 mm²; 5 m; 1,00 mm²; white

<https://www.wago.com/891-8992/205-502>

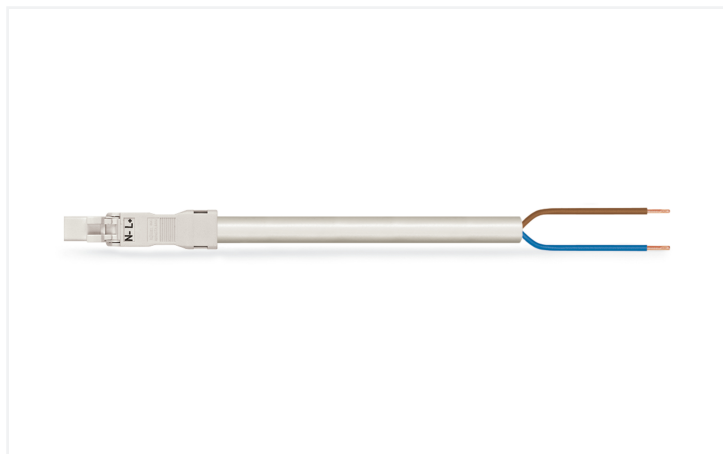

Color: ■ white

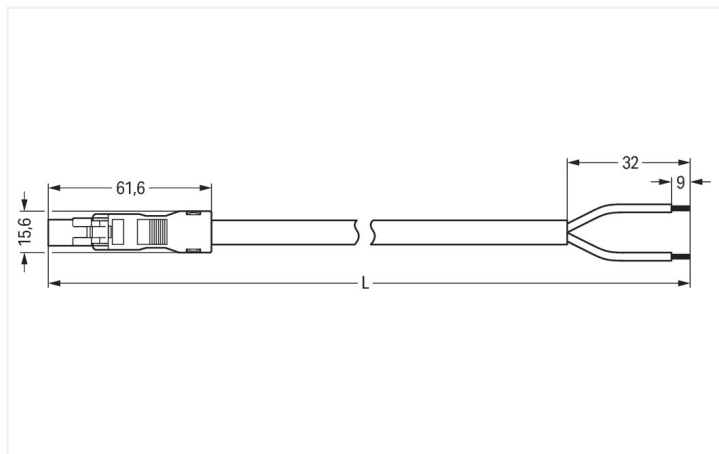

Dimensions in mm

Cable assembly WINSTA® MINI A coding

The WINSTA® MINI cable assembly 2-pole is the pluggable solution for your use in control cabinets, for lighting connections or on PCBs. Whether on PCBs, in control cabinets or for connecting lights – pluggable installation connectors from WAGO allow you to establish connections according to an enormous variety of requirements in seconds. The coding options reduce installation errors, allowing fast, maintenance-free wiring of all components. Standard mains applications for almost any domain of use can be realised with WINSTA® MINI pluggable installation connectors with A coding. WINSTA® MINI satisfies the demand for miniaturisation. Our smallest pluggable connection system is very good for lights, for example, since due to LED technology, these offer less and less space for the connection technology. According to the European CPR, the fire class of the cables used for construction is decisive for the safety of buildings, too. For buildings with medium-level safety requirements, cable assemblies with fire class E are suitable.

Pluggable connections instead of screw connections – cable assemblies from WAGO

A plug and a free end are provided. The WINSTA® Pluggable Connection System is ideally tailored to the strict requirements of building installation. It makes electrical installation pluggable, and thus more efficient, even more reliable, and error-free. Using this pre-assembled system decreases assembly times and installation errors at the construction site. Choose durability and quality – with protection type IP20 from WAGO makes the electrical installation of electrical components significantly easier.

- pluggable installation connectors with protection against mismatching
- consistent IP40 protection
- for any mains application
- ready for immediate use
- convenient installation and commissioning

Notes

Note Cables with a different fire class can be found in the eShop.

Electrical data

Ratings per	IEC/EN 60664-1		
Overvoltage category	III	III	II
Pollution degree	3	2	2
Nominal voltage	250 V	-	-
Rated impulse withstand voltage	4 kV	-	-
Rated current	10 A	-	-

General information

Note on contact resistance approx. 1 mΩ of contact resistance
approx. 0.25 mΩ contact transition plug/
socket

Connection Data

Total number of potentials	2	Connection 1	
Conductor preparation	ultrasonically tip-bonded	Strip length	9 mm / 0.35 inches
		Pole number	2
		Wire cross-section	1 mm ²
		Strip length (outer insulation)	32 mm
		Connection type	Plug - free end

Physical data

Pin spacing	4.4 mm / 0.173 inches
Width	15.6 mm / 0.614 inches
Height	13.2 mm / 0.52 inches
Total length	5 m

Mechanical data

Use	General mains applications
Coding	A
Variable coding	No
Marking	L N
Potential marking	L N
Mating force of a plug-in connection	approx. 20 ... 70 N (depending on pole number)
Retention force of a plug-in connection	when locked: > 80N
Unmating force of a plug-in connection	when unlocked: approx. 20 ... 70 N (depending on pole number)
Number of mating cycles	200, without resistive load
Connection type	Plug - free end
Type of pre-assembled cable	Connecting cable
Cable type	H05VV-F 2x1
Protection type	IP20; IP40 when mated

Plug-in connection

Mismating protection	Yes
Note on mismating protection	All <i>WINSTA</i> ® components are 100% protected against mismating when: a.) plugging different numbers of poles b.) plugging while rotated 180 c.) plugging while laterally staggered d.) plugging one pole
Locking lever	Can be retrofitted
Locking of plug-in connection	Locking lever
Note on locking system	All connectors for mounted installations (snap-in versions for lighting fixtures or devices, all types of PCB and distribution connectors) are factory-equipped with locking levers to ensure plugs and sockets are securely locked. Additional locking levers are only required for flying leads (plug/socket).

Material data

Note (material data)	Information on material specifications can be found here
Color	white
Insulation material (main housing)	Polyamide (PA66)
Fire class per EN 50575	E _{ca}
Contact material	Copper or copper alloy; surface-treated
Contact Plating	Tin
Fire load	149.686 MJ
Connector color	white
Strain relief color	white
Sheathed cable color	white

Material data

Printing color of sheathed cable	black
Halogen-free	No
Silicon-free	Yes
Sheath material	PVC
Rubber cable	No
Weight	289.7 g
Copper weight of the raw cable	0.0192 kg/m

Environmental requirements

Processing temperature	-5 ... +40 °C
Continuous operating temperature	-35 ... +85 °C
Note on continuous operating temperature	Cable for temperatures ≤ 70 °C (including halogen-free) Insulating parts for temperatures ≤ 105 °C

Commercial data

PU (SPU)	1 pcs
Packaging type	unpacked
Country of origin	PL
GTIN	4055143362412
Customs tariff number	85444290900

Product Classification

UNSPSC	26121629
eCl@ss 10.0	27-44-06-04
eCl@ss 9.0	27-44-06-04
ETIM 9.0	EC002587
ETIM 10.0	EC002587
ECCN	NO US CLASSIFICATION

Environmental Product Compliance

RoHS Compliance Status	Compliant, No Exemption
------------------------	-------------------------

Downloads

Environmental Product Compliance

Compliance Search

Environmental Product
Compliance
891-8992/205-502



Documentation

Bid Text

891-8992/205-502	19.02.2019	xml 2.99 KB	
891-8992/205-502	21.11.2014	doc 24.00 KB	

CAD/CAE-Data

CAE data

EPLAN Data Portal 891-8992/205-502	
WSCAD Universe 891-8992/205-502	

1 Compatible Products

1.1 Required Accessories

1.1.1 Locking system

1.1.1.1 Locking system



Item No.: 890-111

Locking lever; for flying leads; for tool operation; black



Item No.: 890-131

Locking lever; for flying leads; for tool operation; white



Item No.: 890-101

Locking lever; for manual operation; black



Item No.: 890-121

Locking lever; for manual operation; white

1.2 Optional Accessories

1.2.1 Cover

1.2.1.1 Cover



Item No.: 897-2001

Protective cap; Type1; for sockets and plugs; PVC; red

1.2.2 Installation

1.2.2.1 Mounting accessories



Item No.: 890-310

Mounting carrier; 2- to 5-pole; for flying leads; black



Item No.: 890-311

Mounting carrier; 2- to 5-pole; for flying leads; white

Subject to changes. Please also observe the further product documentation!

Current addresses can be found at: www.wago.com