

Data Sheet | Item Number: 771-8992/116-102

pre-assembled connecting cable; Eca; Socket/open-ended; 2-pole; Cod. A;
H05Z1Z1-F 2 x 1,50 mm²; 1 m; 1,50 mm²; white

<https://www.wago.com/771-8992/116-102>

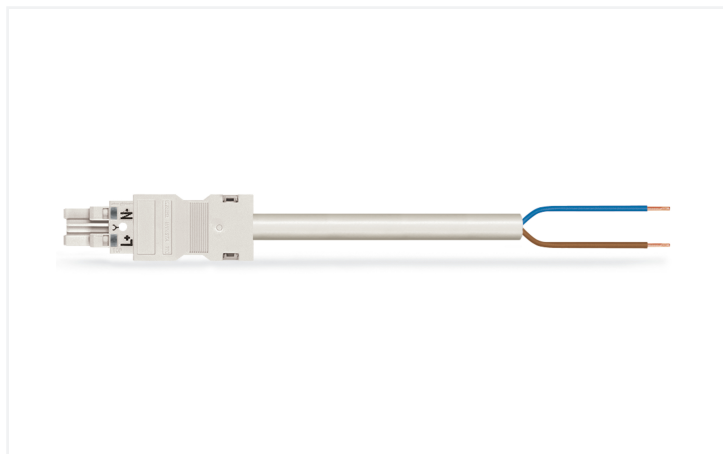

Color: ■ white

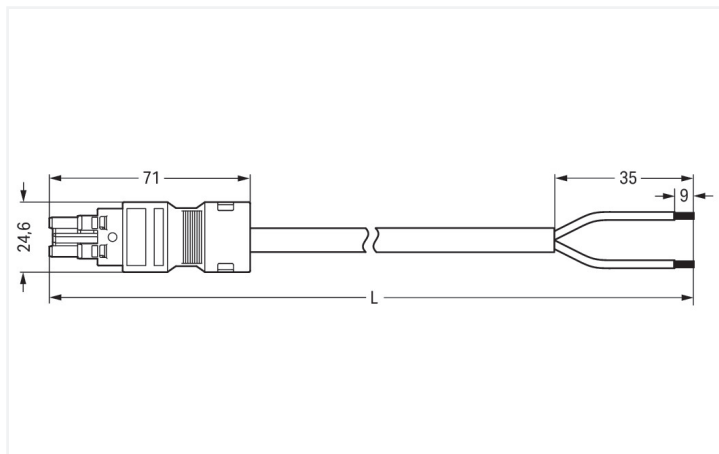

Dimensions in mm

Cable assembly WINSTA® MIDI A coding

For signal and power transmission: The WINSTA® MIDI cable assembly A coding. Whether on PCBs, in control cabinets or for connecting lights – pluggable installation connectors from WAGO allow you to establish connections according to many different requirements in next to no time. The coding options reduce installation errors, allowing fast, secure wiring of all components. The pluggable installation connector offers touch-proof protection with live components in accordance with protection type IP20 (When mated: IP2xC (These compact connectors are not designed for use in open, easily accessible areas!)). Thanks to the color coding and mechanical A coding of WINSTA® MIDI pluggable installation connectors, you can clearly distinguish different circuits. WINSTA® MIDI with Push-in CAGE CLAMP® spring pressure connection technology is used in can be found in a variety of projects you can use for quick, easy and maximally flexible electrical installation. According to the European CPR, the fire class of the cables used for construction is decisive for the safety of buildings, too. For buildings with average safety requirements, cable assemblies with fire class E are suitable. Eliminating halogens as an additive in the production of this cable assembly significantly increases fire safety and minimises environmental contamination.

Pluggable connections instead of screw connections – cable assemblies from WAGO

The cable is pre-assembled with a socket and a free end. The WINSTA® Pluggable Connection System is perfectly tailored to the very strict requirements of building installation. It makes electrical installation pluggable, and thus faster, even more reliable, and error-free. Use of this pre-assembled system reduces assembly times and errors during installation at the construction site. Now you can also cut installation costs without compromising safety and quality: with protection against mismatching reduces the need for servicing and prevents unnecessary downtime.

- pluggable installation connectors with protection against mismatching
- for automation controllers
- with A coding for a large number of uses
- custom-engineered solutions
- quick replacement of defective units during ongoing operation

Notes

Note

Cables with a different fire class can be found in the eShop.

Electrical data

Ratings per	IEC/EN 60664-1		
Overvoltage category	III	III	II
Pollution degree	3	2	2
Nominal voltage	250 V	-	-
Rated impulse withstand voltage	4 kV	-	-
Rated current	16 A	-	-

General information

Note on contact resistance	approx. 1 mΩ of contact resistance approx. 0.25 mΩ contact transition plug/ socket
----------------------------	--

Connection Data

Total number of potentials	2
Conductor preparation	ultrasonically tip-bonded

Connection 1

Strip length	9 mm / 0.35 inches
Pole number	2
Wire cross-section	1.5 mm ²
Strip length (outer insulation)	35 mm
Connection type	Socket - free end

Physical data

Pin spacing	10 mm / 0.394 inches
Width	24.6 mm / 0.969 inches
Height	15.9 mm / 0.626 inches
Total length	1 m

Mechanical data

Use	General mains applications
Coding	A
Variable coding	No
Marking	L N
Potential marking	L N
Mating force of a plug-in connection	approx. 20 ... 70 N (depending on pole number)
Retention force of a plug-in connection	when locked: > 80N
Unmating force of a plug-in connection	when unlocked: approx. 20 ... 70 N (depending on pole number)
Number of mating cycles	200, without resistive load
Connection type	Socket - free end
Type of pre-assembled cable	Connecting cable
Cable type	H05Z1Z1-F 2x1.5
Protection type	IP20; When mated: IP2xC (These compact connectors are not designed for use in open, easily accessible areas!)

Plug-in connection

Mismating protection	Yes
Note on mismating protection	All <i>WINSTA</i> ® components are 100% protected against mismating when: a.) plugging different numbers of poles b.) plugging while rotated 180 c.) plugging while laterally staggered d.) plugging one pole
Locking lever	Can be retrofitted
Locking of plug-in connection	Locking lever
Note on locking system	All connectors for mounted installations (snap-in versions for lighting fixtures or devices, all types of PCB and distribution connectors) are factory-equipped with locking levers to ensure plugs and sockets are securely locked. Additional locking levers are only required for flying leads (plug/socket).

Material data

Note (material data)	Information on material specifications can be found here
Color	white
Insulation material (main housing)	Polyamide (PA66)
Fire class per EN 50575	E _{ca}
Contact material	Copper or copper alloy; surface-treated
Contact Plating	Tin
Fire load	29.704 MJ
Connector color	white
Strain relief color	white
Sheathed cable color	white
Printing color of sheathed cable	black
Halogen-free	Yes
Silicon-free	Yes
Sheath material	Halogen-free
Rubber cable	No
Weight	90.4 g
Copper weight of the raw cable	0.029 kg/m

Environmental requirements

Processing temperature	-5 ... +40 °C
Continuous operating temperature	-35 ... +85 °C
Note on continuous operating temperature	Cable for temperatures ≤ 70 °C (including halogen-free) Insulating parts for temperatures ≤ 105 °C

Commercial data

PU (SPU)	1 pcs
Packaging type	unpacked
Country of origin	DE
GTIN	4055143445030
Customs tariff number	85444290900

Product Classification

UNSPSC	26121629
eCl@ss 10.0	27-44-06-04
eCl@ss 9.0	27-44-06-04
ETIM 9.0	EC002587
ETIM 10.0	EC002587
ECCN	NO US CLASSIFICATION

Environmental Product Compliance

RoHS Compliance Status	Compliant, No Exemption
------------------------	-------------------------

Approvals / Certificates

General approvals



Approval	Standard	Certificate Name
CCA DEKRA Certification B.V.	EN 61535	NTR NL-7355
KEMA/KEUR DEKRA Certification B.V.	EN 61535	71-123834

Declarations of conformity and manufacturer's declarations

Approval	Standard	Certificate Name
EU-Declaration of Confor- mity WAGO GmbH & Co. KG	-	-
UK-Declaration of Confor- mity WAGO GmbH & Co. KG	-	-

Downloads

Environmental Product Compliance

Compliance Search	
Environmental Product Compliance 771-8992/116-102	↓

Documentation

Bid Text			
771-8992/116-102	19.02.2019	xml 3.00 KB	↓
771-8992/116-102	03.12.2014	doc 25.50 KB	↓

CAD/CAE-Data

CAD data	
2D/3D Models 771-8992/116-102	↓

CAE data	
EPLAN Data Portal 771-8992/116-102	↓
WSCAD Universe 771-8992/116-102	↓
ZUKEN Portal 771-8992/116-102	↓

1 Compatible Products

1.1 Required Accessories

1.1.1 Locking system

1.1.1.1 Locking system



Item No.: 770-101

Locking lever; for flying leads; for manual operation; black

Item No.: 770-121

Locking lever; for flying leads; for manual operation; white

Item No.: 770-111

Locking lever; for flying leads; for tool operation; black

Item No.: 770-131

Locking lever; for flying leads; for tool operation; white

1.2 Optional Accessories

1.2.1 Cover

1.2.1.1 Cover



Item No.: 770-201

Lockout cap; 12-pole, separable; for sockets; Plastic; black

Item No.: 770-221

Lockout cap; 12-pole, separable; for sockets; Plastic; white

Item No.: 897-2003

Protective cap; Type2; for sockets and plugs; PVC; red

1.2.2 Installation

1.2.2.1 Mounting accessories



Item No.: 770-310

Mounting carrier; 2- to 5-pole; for flying leads; black

1.2.3 Marking

1.2.3.1 Marking strip



Item No.: 210-334

Marking strips; as a DIN A4 sheet; Strip width 5 mm; Strip length 182 mm; plain; Self-adhesive; white