

Mounting instructions

Device installation trunking Rapid 80®

Device installation trunking Rapid 80®
Mounting instructions

Table of content

1	About these instructions	5
1.1	Target group	5
1.2	Relevance of these instructions	5
1.3	Types of warning information	5
1.4	Basic standards and regulations	5
1.4.1	Product standard	5
1.4.2	Application standard	6
1.4.3	Guidelines and ordinances	6
1.5	Applicable documents	6
2	Intended use	6
3	Safety	6
3.1	General safety information	6
3.2	Personal protective equipment	7
4	Necessary tools	7
5	System description	7
5.1	System overview	8
6	Mounting the device installation trunking Rapid 80®	10
6.1	Mounting the trunking base	10
6.1.1	Pre-drilling device installation trunking Rapid 80® GA	10
6.1.2	Using the saw core (device installation trunking Rapid 80® GS)	12
6.1.3	Mounting trunking couplings	14
6.2	Mounting fittings	15
6.2.1	Mounting the flat angle cover	17
7	Installing devices	19
7.1	Mounting the Modul 45® device	19
7.2	Mounting the Modul 45 connect® socket	21
7.3	Mounting the support ring devices	22
7.4	Mounting the CEE socket	26
8	Mounting accessories	31
8.1	Earthing the device installation trunking Rapid 80®	34
8.2	Mounting wall penetrations/noise limit barriers	35
9	Caring for the device installation trunking Rapid 80®	37
10	Maintaining the device installation trunking Rapid 80®	37
11	Dismantling the device installation trunking Rapid 80®	37
12	Disposing of the device installation trunking Rapid 80®	37

13 Technical data	38
13.1 Device installation trunking Rapid 80®	38
13.2 Fittings	39
13.2.1 Internal corner	39
13.2.2 External corner	42
13.2.3 Flat angle	43
13.2.4 End piece	46
13.2.5 T piece	48
13.3 Accessories	49
13.3.1 Cover	49
13.3.2 Joint cover	51
13.3.3 Partition	51
13.3.4 Accessory mounting boxes	52
13.3.5 Wall end piece	52
13.3.6 Mounting support for accessory mounting boxes	53
13.3.7 Cover frame	53
13.3.8 Saw cores	54
13.3.9 Additional accessory parts	55

1 About these instructions

1.1 Target group

These instructions are intended for the following target groups:

- Trained electrical specialists charged with mounting the Rapid 80® device installation trunking
- Electrical planners and engineers charged with the planning of cable routing systems

Electrical work may only be carried out by specialist personnel with electrical training.



1.2 Relevance of these instructions

These instructions are based on the standards valid at the time of compilation (March 2025).

Please read the instructions carefully before commencing mounting. We will not accept any warranty claims for damage and liability caused through non-observance of these instructions.

Any images are intended merely as examples. Mounting results may look different.

All the documents supplied with the product must be stored in an easily accessible location, so as to be available when information is required. (Only for printed instructions)

In these instructions, cables and lines are referred to simply as cables.

To find out more about planning and mounting the product, we recommend a comprehensive training course.

1.3 Types of warning information

Note! *Indicates important information or assistance.*

1.4 Basic standards and regulations

1.4.1 Product standard

- DIN EN 50085, VDE 0604-2-1:2012-09 “Cable trunking systems and cable ducting systems for electrical installations”
- EN 50310: Telecommunications bonding networks for buildings and other structures
- prEN 50642: Cable management systems – Test method for content of halogens

1.4.2 Application standard

- DIN VDE 0100 – Part 410: Protection measures
- DIN VDE 0100 – Part 520: Selection and erection of electrical equipment/Protection against external electrical influences (EMC)
- DIN VDE 0105: Operation of electrical installations (general requirements)
- DIN VDE 0107: Heavy-current installations in medical rooms
- DIN VDE 0298: Application of cables and cords in power installations
- EN 50174: Information technology – Cabling installation
- DIN 18015-1: Electrical installations in residential buildings – Part 1: Planning principles

1.4.3 Guidelines and ordinances

- Safety regulations for office workstations
- Protection against unauthorised access, e.g. in administrations, military or similar
- Shock protection for protection areas for civil defence

1.5 Applicable documents

- The declarations of conformity are linked to the products at www.obo-bettermann.com.
- For symbol approvals, see <https://www.obo.de/service/downloads/zertifikate/gebaeudeinstallation/leitungsfuehrungs-systeme/>

2 Intended use

Device installation trunking systems are manufactured according to the standard and may only be used for routing cables. Electrical installation devices (e.g. sockets, data technology supports or multimedia connections) with a rated voltage of up to 400 V can be installed in the device installation trunking systems. Depending on the version, the device installation trunking systems are designed for use at different ambient temperatures. The device installation trunking systems are only approved for use in dry interior areas.

3 Safety

3.1 General safety information

Observe the following general safety information:

- Contact with electrical current can lead to an electric shock.
- Risk of cutting from plate edges.
- Electrical work may only be carried out by specialist personnel with electrical training.
- Cable routing systems may not be used as supports for people or heavy objects.
- Improper mounting or mounting deviating from the manufacturer's specifications may cause the cable routing system to collapse.
- Depending on the version, the cable routing systems are designed for use at different ambient temperatures.
- Do not stand on painted or coated surfaces, in order to prevent damage to the surfaces.

3.2 Personal protective equipment

List of personal protective equipment to be used:



Use hand protection



Wear safety shoes

4 Necessary tools

List of tools to be used:

- Screwdriver
- Saw
- Drill
- Spirit level
- Pencil

5 System description

5.1 System overview











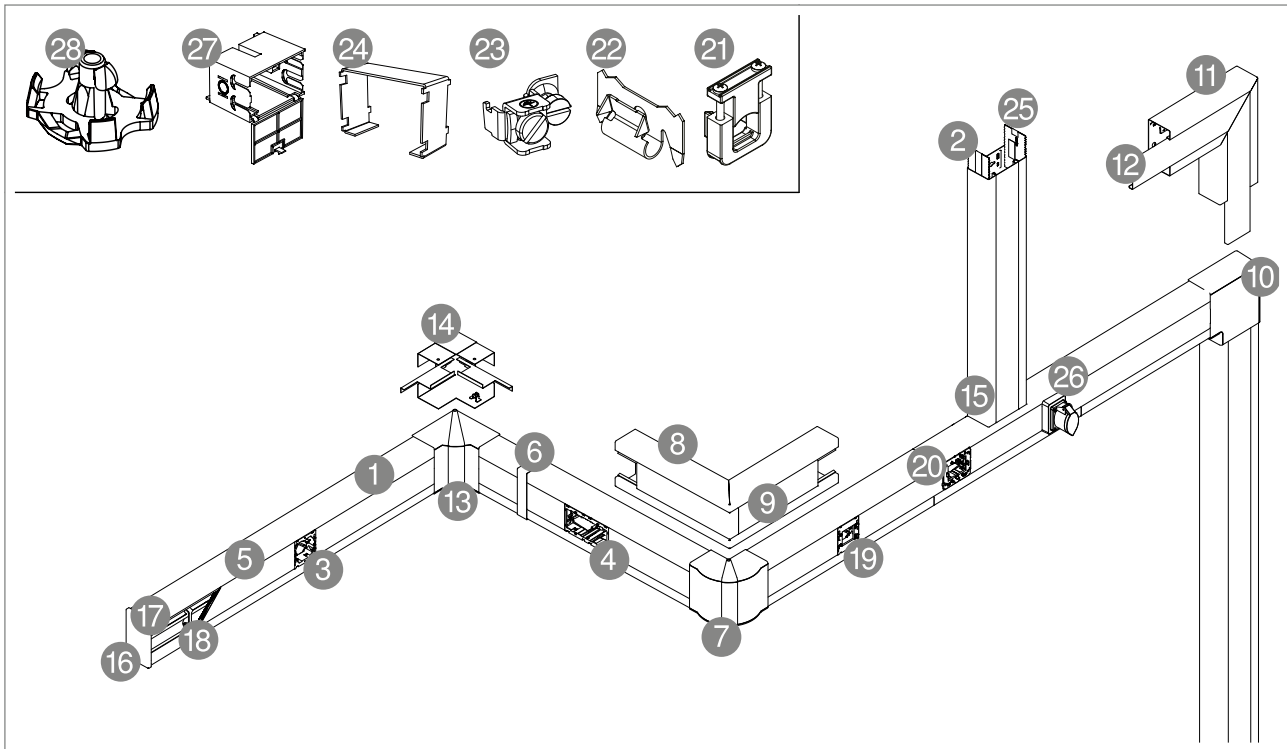
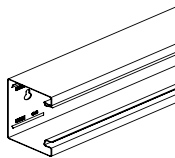
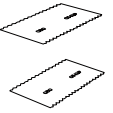
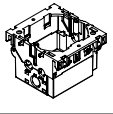
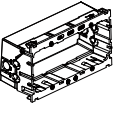

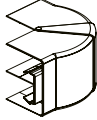

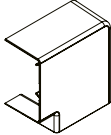

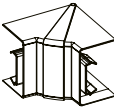

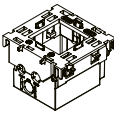
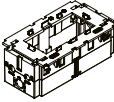

Abb. 1: System overview, device installation trunking Rapid 80®

Item no.	Designation	Figure	Function
1	Device installation trunking		Device installation trunking Rapid 80® for mounting on the wall or on fastening panels. The device installation trunking made of sheet steel possesses self-contacting locking straps to accept a sheet steel partition. The equipotential bonding between the trunking bases takes place using the coupling. The protective measure and the equipotential bonding is guaranteed between the cover and the base by the self-contacting trunking cover. The actual system opening is 76.5 mm. The cover must be ordered separately.
2	Coupling GS-KUP		Coupling GS-KUP for connecting the trunking bases made from steel and aluminium. This creates the equipotential bonding between the trunking bases. The scope of delivery of a coupling includes 2 connection plates.
3	Accessory mounting box 71GD6		Front locking accessory mounting box for switch systems, with folding, and also removable, base for time-saving cable connection, with feed openings for cable diameters of up to 14 mm. Halogen-free version.
4	Accessory mounting box 71GD7		Front-locking accessory mounting box for standard switch ranges for the installation of two individual installation devices or a multiple protective contact socket. With unfolding, and also removable, base for time-saving cable connection and with feed openings for cable diameters of up to 14 mm. Halogen-free version.
5	Cover		Cover for closing the Rapid 80® device installation trunking.
6	Joint cover		Joint cover to hide sawn trunking joint edges.

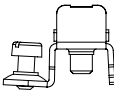
Item no.	Designation	Figure	Function
7	External corner cover		External corner cover made of halogen-free PC/ABS for changing the direction of Rapid 80® device installation trunking. The fittings can be variably adjusted between 80° and 100° and can be used in symmetrical and asymmetrical device installation trunking.
8	External corner		External corner for changing the direction of the device installation trunking Rapid 80®.
9	External corner cover		Cover for closing the external corner of the Rapid 80® device installation trunking.
10	Flat angle cover		Flat angle hood fitting made of halogen-free PC/ABS for simple creation of a rising or falling 90° change of direction with device installation trunking Rapid 80®. The flat angle cover fitting can be used for symmetrical and asymmetrical trunking types.
11	Flat angle		Flat angle for changing the direction of the Rapid 80® device installation trunking.
12	Flat angle cover		Cover for closing the flat angle of the Rapid 80® device installation trunking.
13	Internal corner cover		Internal corner cover made of halogen-free PC/ABS for changing the direction of Rapid 80® device installation trunking. The fittings can be variably adjusted between 85° and 95° and can be used in symmetrical and asymmetrical device installation trunking Rapid 80®.
14	Internal corner		Internal corner for direct installation on device installation trunking Rapid 80®.
15	T piece		T piece suitable for direct wall mounting.
16	End piece		End piece for Rapid 80® device installation trunking.
17	Partition		Partition to divide the device installation trunking Rapid 80® for different voltage levels. Self-conducting contacting during installation.
18	Duct clamp		Duct clamp for holding cables securely and for fastening the partition in device installation trunking systems Rapid 80® with a 76.5 mm system opening.
19	Accessory mounting box 71GD8		Front-locking single accessory mounting box for Modul 45® system, with folding, and also removable, base for time-saving cable connection, with feed openings for cable diameters of up to 14 mm.
20	Accessory mounting box 71GD13		Front-locking double accessory mounting box for Modul 45® system, with folding, and also removable, base for time-saving cable connection, with feed openings for cable diameters of up to 14 mm.
21	Strain relief		Strain relief with locking clips, suitable for the accessory mounting boxes.
22	Locking bracket		Locking bracket for the mechanical and electrical connection of trunking covers and trunking bases.
23	Protective conductor connection bracket		Protective conductor connection bracket to include steel and aluminium device installation trunking, service poles and system components of underfloor trunking systems in the protective measure. Clamping range: 2 x 1.5–4 mm ²

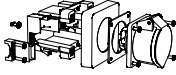
Item no.	Designation	Figure	Function
24	Cutting block		Saw core for easy creation of saw cuts on device installation trunking Rapid 80® made from sheet steel. Suitable for nominal size in the type.
25	GK-KUP coupling		GK-KUP coupling as trunking connector for tight connection of the trunking sections. A coupling pair is included and pre-mounted for each stock length.
26	Accessory mounting box 71GDCEE		Accessory mounting box for installation of a 3-pole or 5-pole CEE socket, 16 A or 32 A.
27	Connection plug		Connection socket for wiring in device installation trunking and service poles. The socket can be coupled by locking onto accessory mounting boxes of the series 71GD...
28	Universal adapter		Universal adapter for the direct installation of plastic cable ducts or equipment mounting ducts using installation tools.

Tab. 1: System overview, device installation trunking Rapid 80®

Device installation trunking Rapid 80® for routing electrical cables indoors. With base perforation for direct mounting on the wall. Device installation possible with accessory mounting boxes. Consisting of trunking base and cover. With 76.5 mm system opening and C profile on the trunking base for a partition to separate different voltage levels. Fittings for direction changes, end pieces for closing trunking ends and accessory parts available. Available in a variant made of plastic (also halogen-free), sheet steel or aluminium and in different dimensions (110 x 70 mm, 130 x 70 mm, 170 x 70 mm, 210 x 70 mm and 110 x 90 mm, 130 x 90 mm, 170 x 90 mm, 210 x 90 mm). Tested to DIN EN 50085-1. The device installation trunking is available in a symmetrical and asymmetrical version.

The many practical fittings permit easy integration of the Rapid 80® device installation trunking system into any office situation. Switches, sockets and data technology are mounted with the accessory mounting boxes.

6 Mounting the device installation trunking Rapid 80®

6.1 Mounting the trunking base

Note! *Device installation trunking Rapid 80® can also be mounted with fastening panels BKN.*

6.1.1 Pre-drilling device installation trunking Rapid 80® GA

Note! *This step is only required for the variant made from aluminium.*

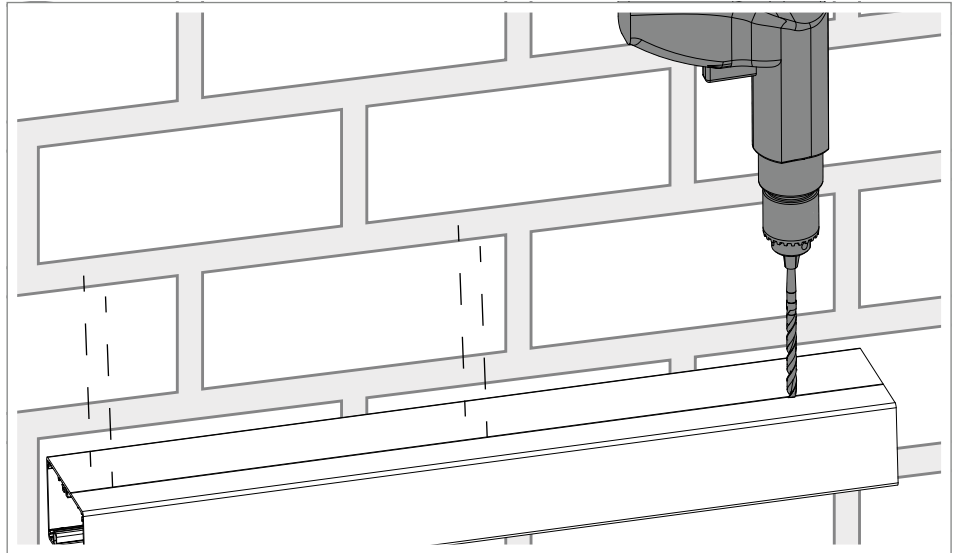

Fig. 2: Pre-drilling device installation trunking Rapid 80® GA

1. Pre-drill device installation trunking Rapid 80® GA ① at the desired fastening points.

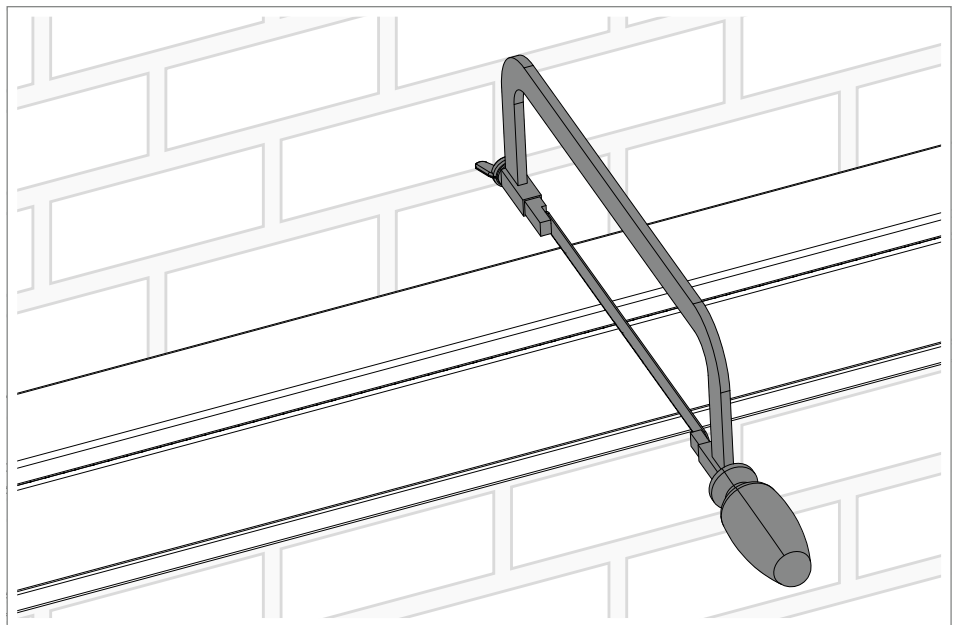

Fig. 3: Cutting device installation trunking Rapid 80® GS/GA/GK

Note!

The device installation trunking Rapid 80® made from aluminium should only be processed using an electrical circular or coping saw, and the device installation trunking Rapid 80® made from plastic with a coping saw. Device installation trunking Rapid 80® made from steel is processed with an angle grinder.

2. Cut device installation trunking Rapid 80® GS/GA/GK ① to the desired length.

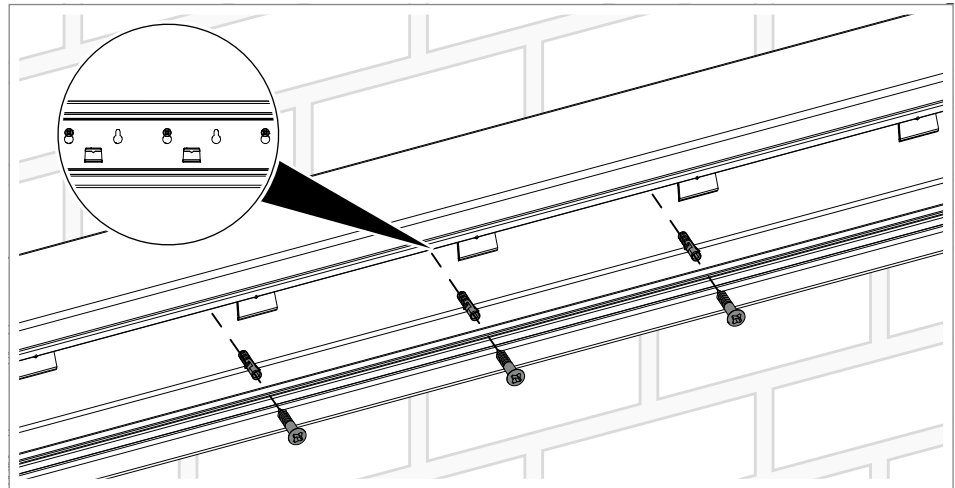

Fig. 4: Mounting the device installation trunking Rapid 80® GS/GA/GK

3. Fasten the device installation trunking Rapid 80® GS/GA/GK ① to the wall using suitable fastening material (e.g. screw and anchor).

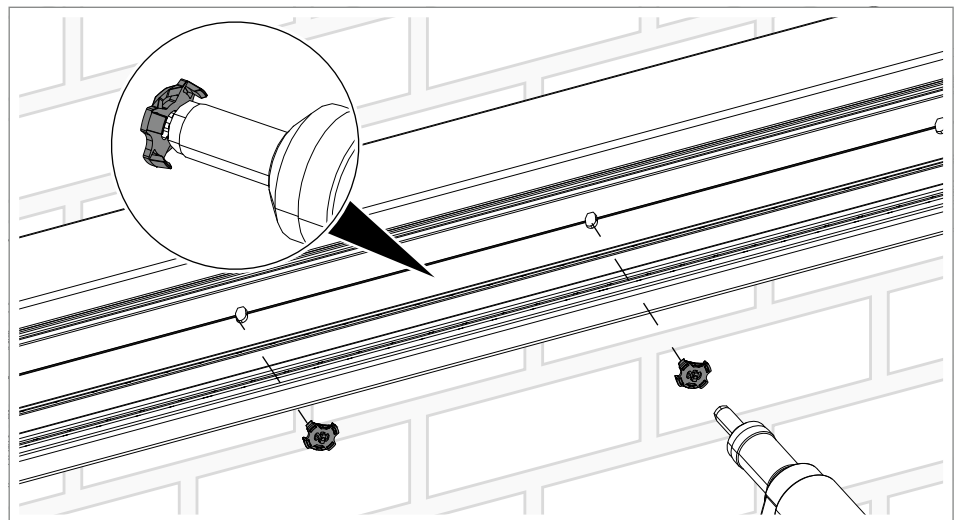

Fig. 5: Mounting the device installation trunking Rapid 80® GK

Note! *This step applies to the variant made from aluminium and plastic.*

4. Fasten the device installation trunking Rapid 80® GK ① to the wall using the universal adapter ②.

6.1.2 Using the saw core (device installation trunking Rapid 80® GS)

Saw core for easy creation of saw cuts on device installation trunking Rapid 80® made from sheet steel. Suitable for nominal size in the type.

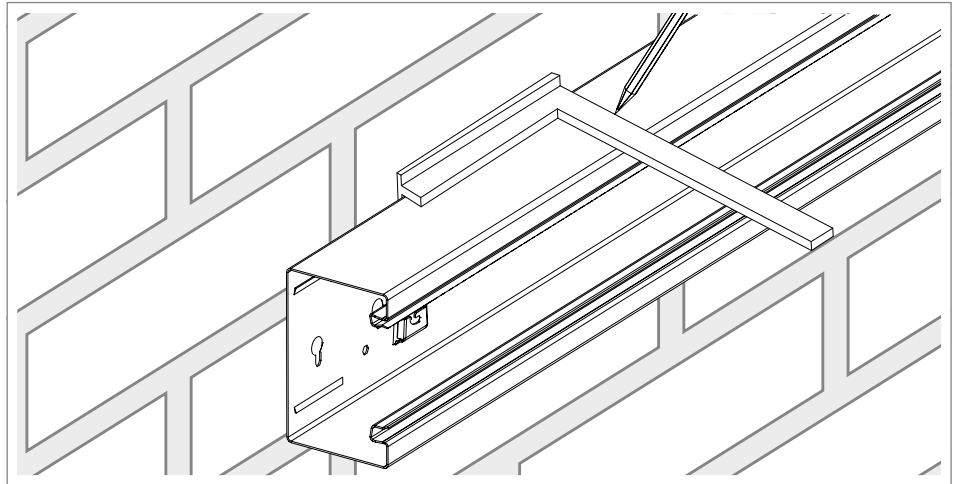

Fig. 6: Marking the cutting point

1. Mark the cutting point.

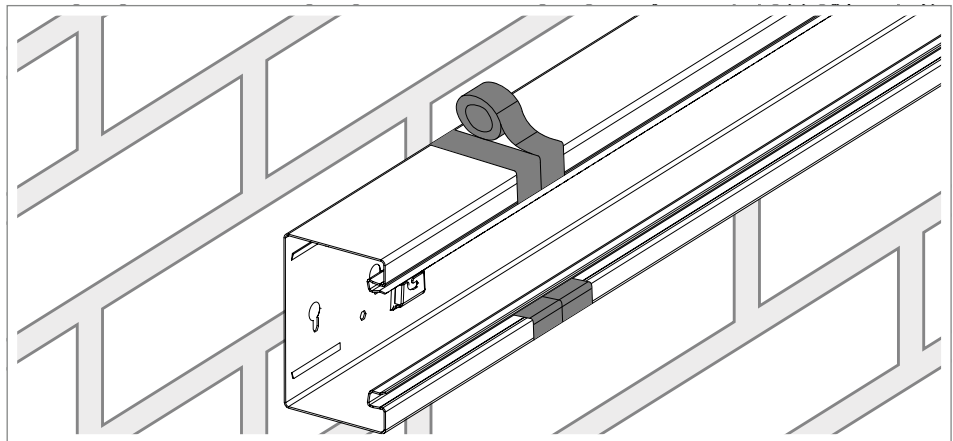

Fig. 7: Masking the interface

2. Mask the pre-marked cutting point on the left and right with adhesive tape.

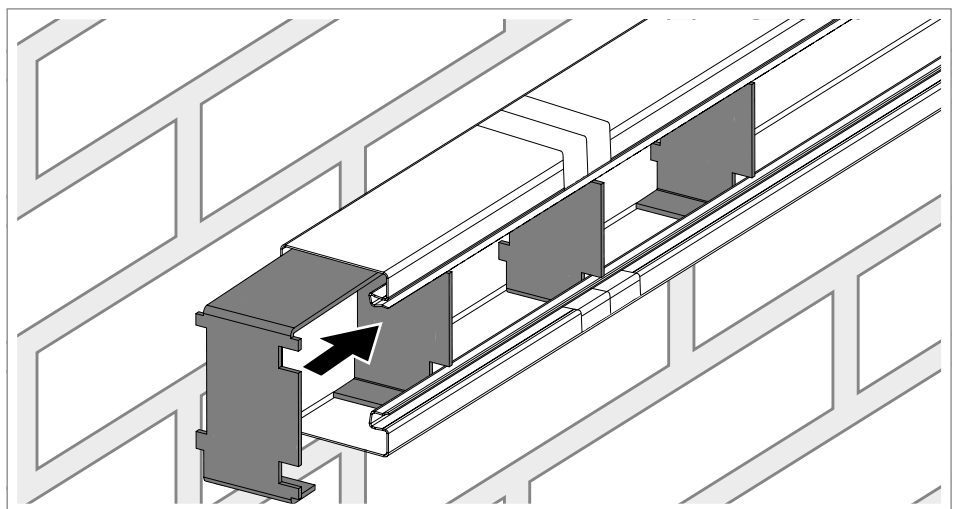

Fig. 8: Inserting the saw core

3. Insert the saw cores ²⁴ to the left and right of the saw blade.

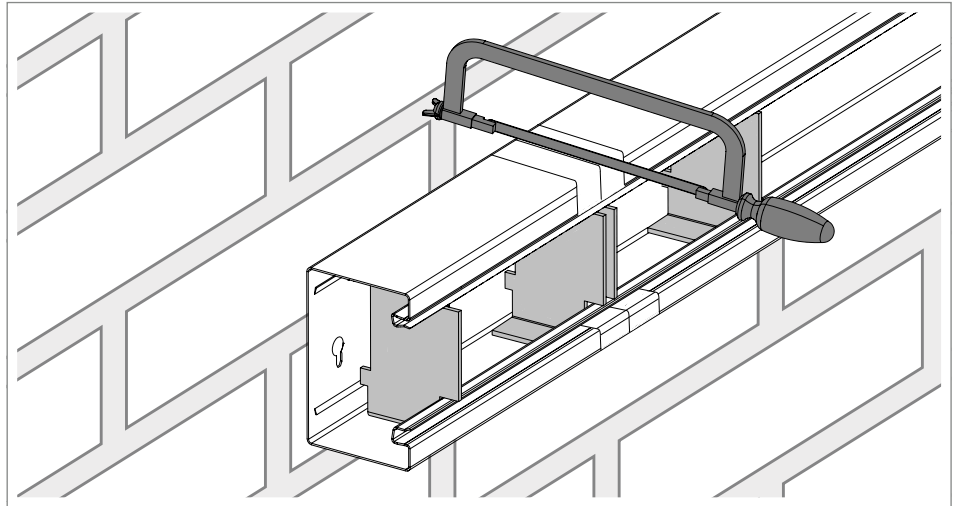

Fig. 9: Cutting device installation trunking Rapid 80® GS to size

4. Cut device installation trunking Rapid 80® GS ① to size.

6.1.3 Mounting trunking couplings

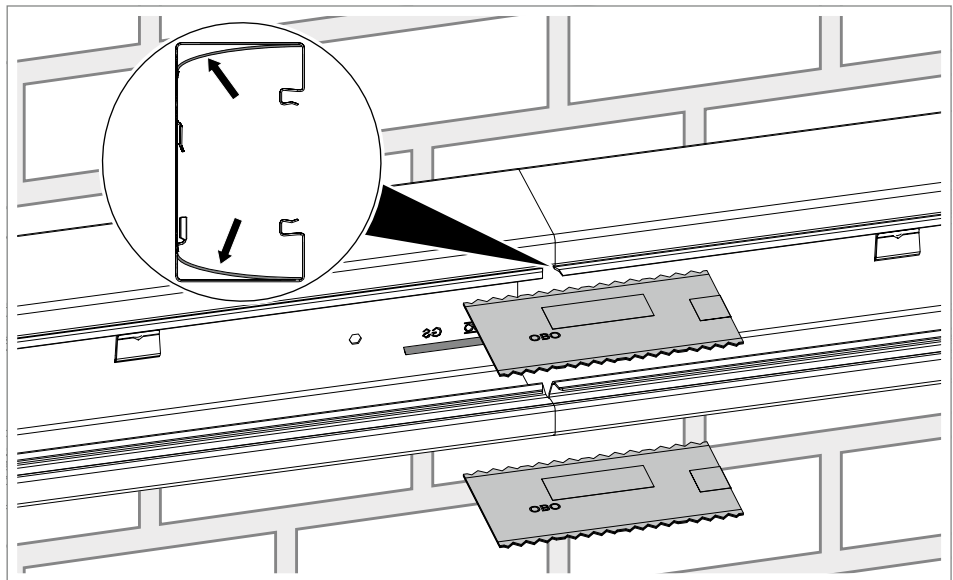

Fig. 10: Connecting device installation trunking Rapid 80® GS/GA

Note! *At the same time, the coupling creates the equipotential bonding between the two trunking bases.*

Note! *With cut lengths, the coupling is clamped in the device installation trunking Rapid 80® GS/GA on both sides.*

1. Claw the coupling GS-KUP ② onto the fastening strap of the device installation trunking Rapid 80® GS/GA ①.

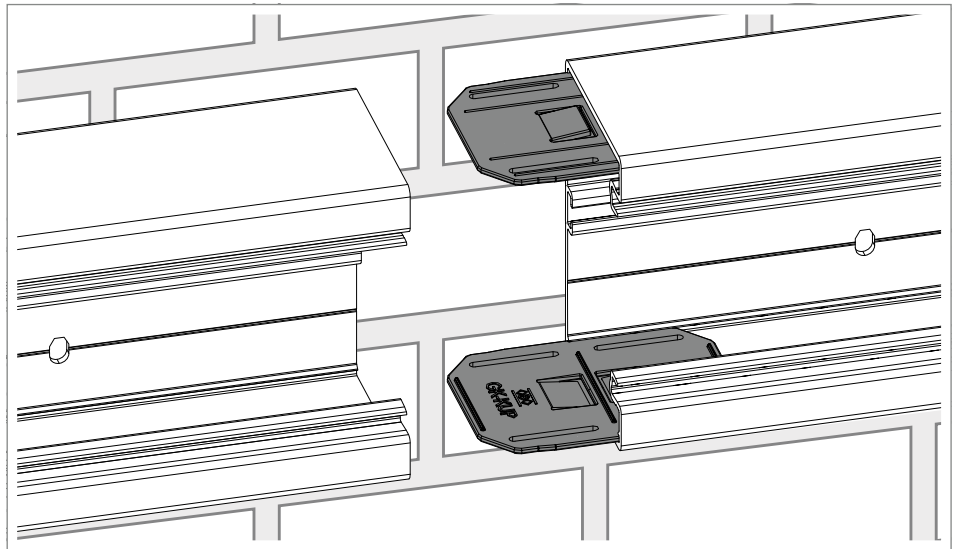

Fig. 11: Connecting device installation trunking Rapid 80® GK

2. Engage the coupling GK-KUP 25 into the device installation trunking Rapid 80® GK 1 until it stops.

6.2 Mounting fittings

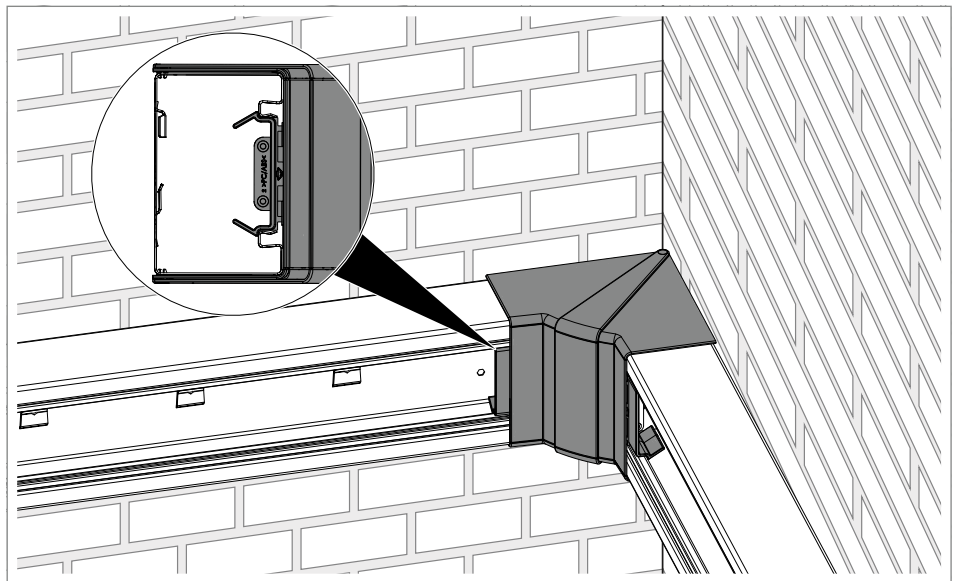

Fig. 12: Mounting hood fittings

Note!

A correction of 80–110° is possible with the variable hood fittings.

1. Mount the device installation trunking Rapid 80® 1 to the end of the wall.
2. Plug the hood fittings 7/13 on the device installation trunking Rapid 80® 1.
3. Snap the hood fittings 7/13 into the cover contour.

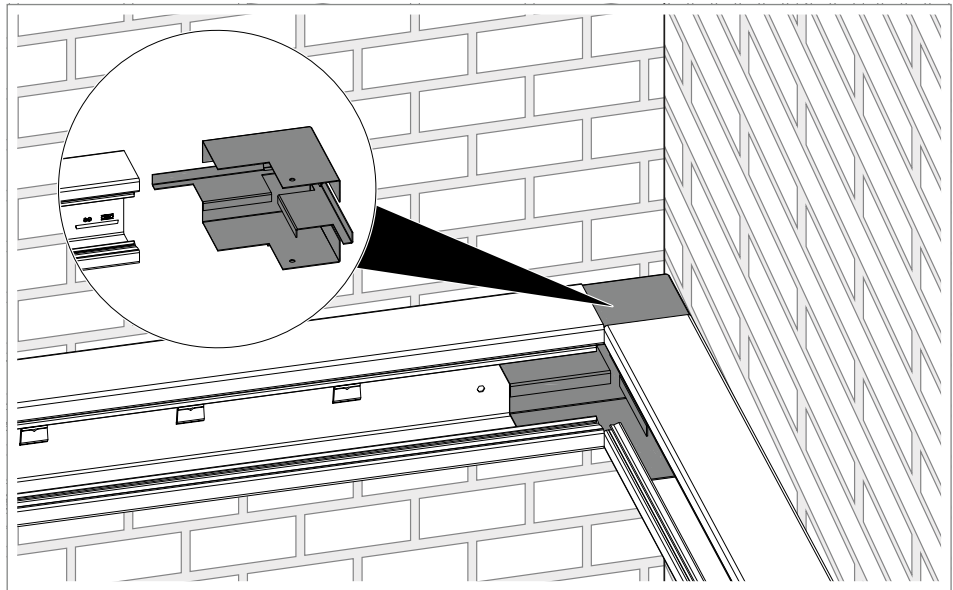

Fig. 13: Mounting fittings

4. Fasten the fittings 8/11/14 to the wall in the slots using suitable fastening material (e.g. screw and anchor).
5. Mount the device installation trunking Rapid 80® 1 flush with the fitting 8/11/14.

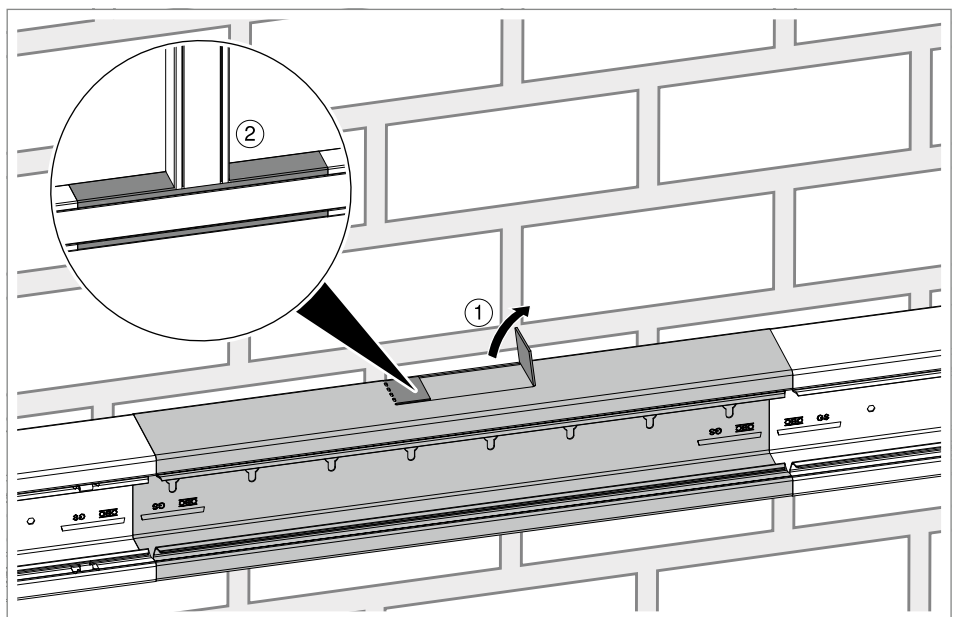

Fig. 14: Mounting the T piece

6. Cut device installation trunking Rapid 80® 1 to size.
7. Insert the T piece 15 between the device installation trunking Rapid 80® 1.
8. Bend the guide strap on device installation trunking Rapid 80® 1 up by 90°.
9. Fasten the device installation trunking Rapid 80® 1 in the slots on

the wall using suitable fastening material (e.g. screw and anchor).

6.2.1 Mounting the flat angle cover

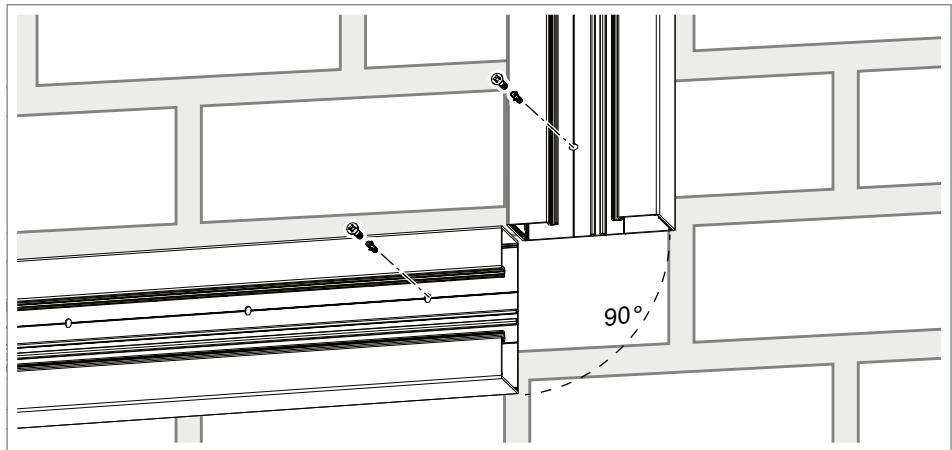

Fig. 15: Mounting the device installation trunking Rapid 80® GK/GS

1. Mount the device installation trunking Rapid 80® GK/GS ① at a 90° angle.

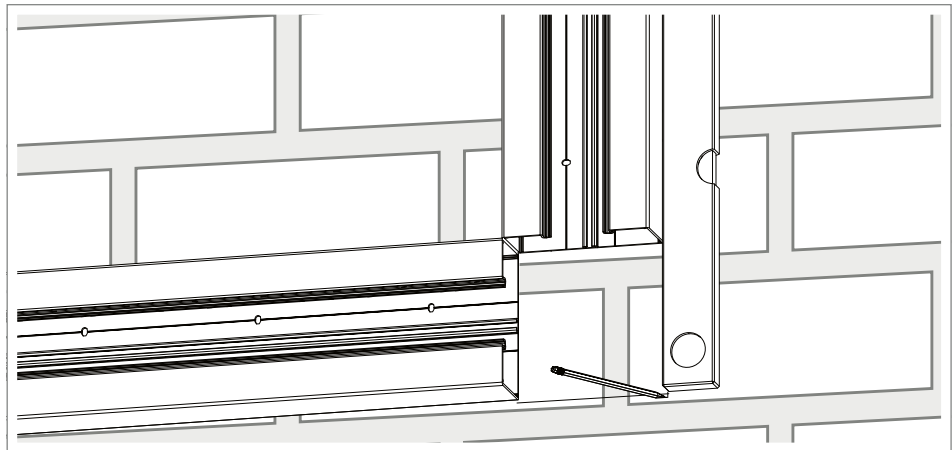

Fig. 16: Drawing the cutting point

2. Using a bar or spirit level, draw the cutting point on both outer sides of the trunking, as shown.

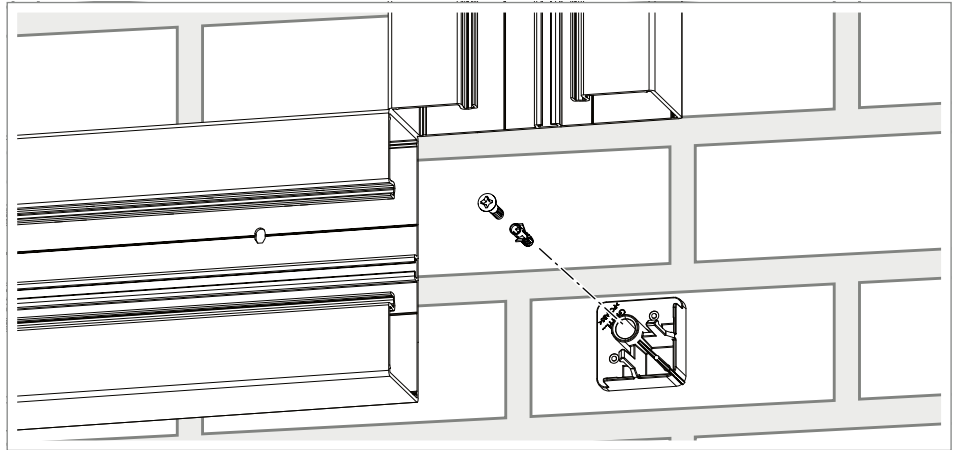

Fig. 17: Mounting the wall holders

3. Mount the wall holder at the cutting point, observing the correct alignment to the device installation trunking Rapid 80® GK/GS ①.

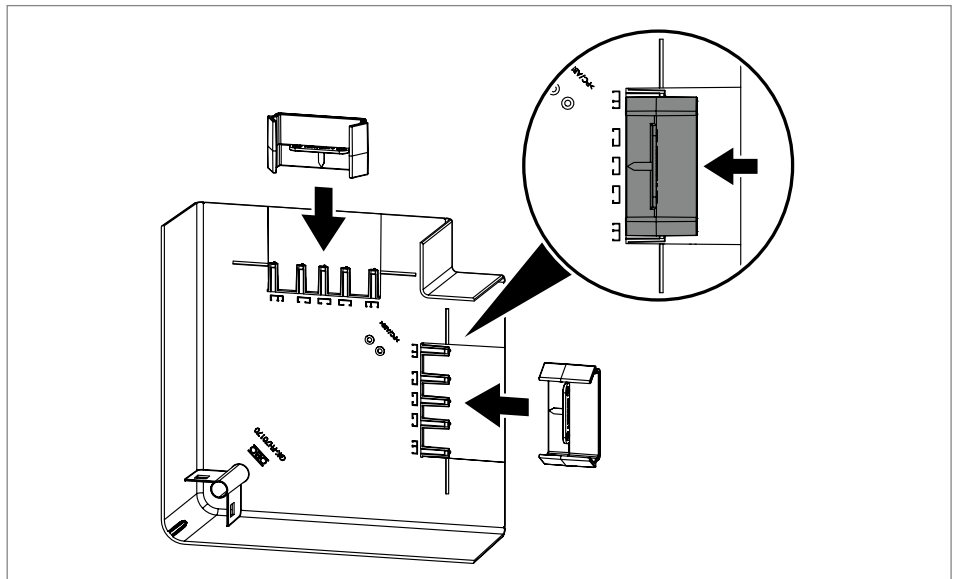

Fig. 18: Pushing the fitting adapters on

4. Push on both fitting adapters: The marked symbols on the inside of the flat angle hood ⑩ (see magnifying glass) show the right guide groove for the device installation trunking Rapid 80® GK/GS. Push the fitting adapters on up to the stop.

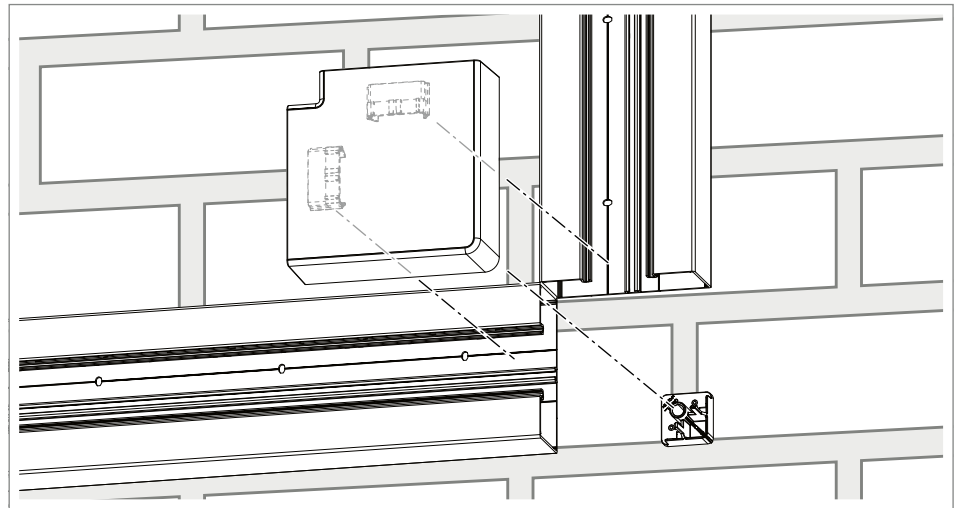

Fig. 19: Pushing the flat angle cover

5. Snap the flat angle cover **10** onto the device installation trunking Rapid 80® GK/GS **1** and wall holder with slight pressure.

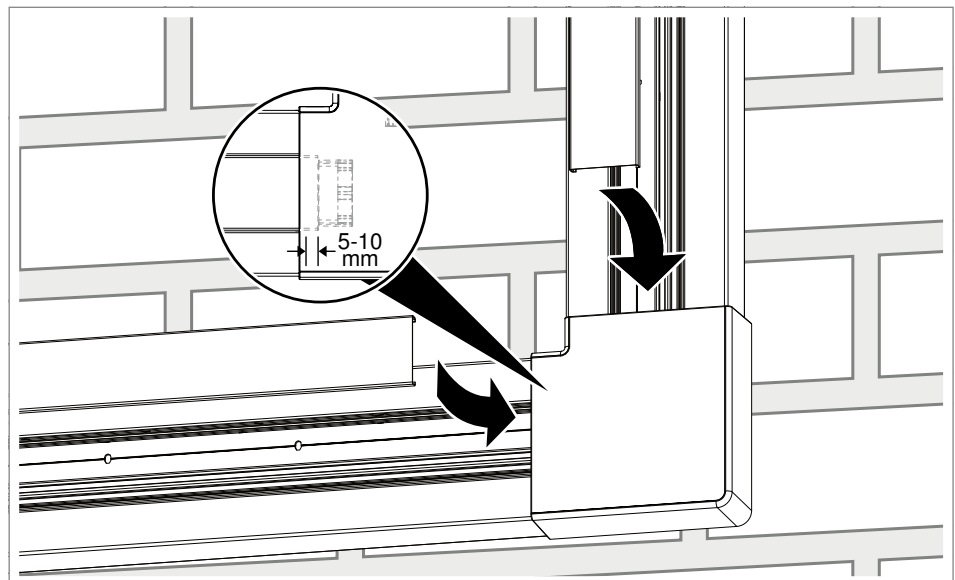

Fig. 20: Mounting the cover

6. Cut the covers **5** and mount them so that they fit 5–10 mm under the flat angle cover **10**.

7 Installing devices

7.1 Mounting the Modul 45® device

Note! *The mounting of the double accessory mounting box takes place in the same way.*

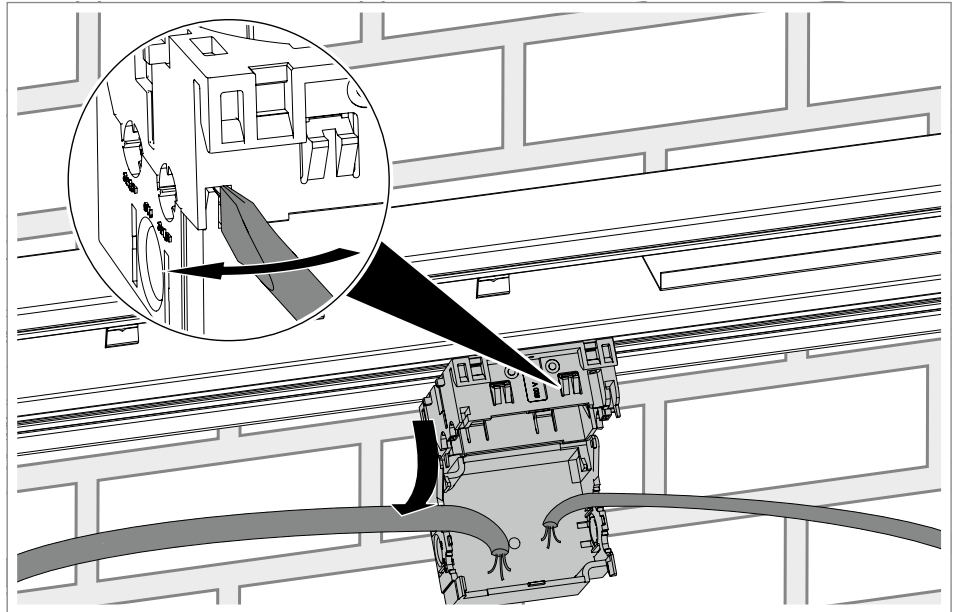

Fig. 21: Connecting the device installation socket

1. Unlock the accessory mounting box 71GD8-2 ¹⁹/71GD13 ²⁰ at the locking hooks using a slotted screwdriver and open accessory mounting box 71GD8-2 ¹⁹/71GD13 ²⁰.
2. Lay the insulated cable in the opened accessory mounting box 71GD8-2 ¹⁹/71GD13 ²⁰ and close the accessory mounting box 71GD8-2 ¹⁹/71GD13 ²⁰.

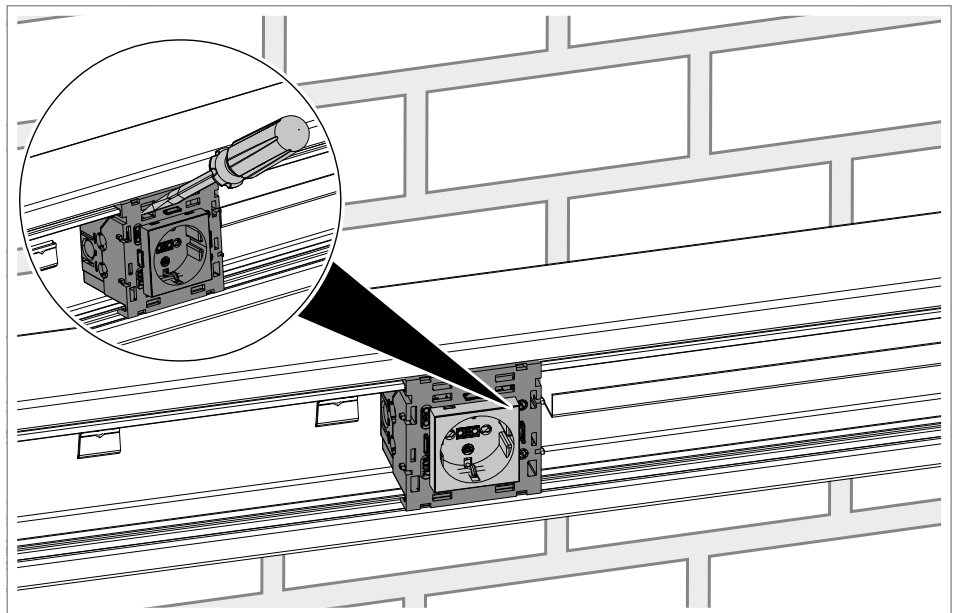

Fig. 22: Engaging the accessory mounting box

3. Engage the accessory mounting box 71GD8-2 ¹⁹/71GD13 ²⁰ in the cover contour of the device installation trunking Rapid 80[®] ¹.

Note!

The accessory mounting boxes can be moved lengthwise in the device installation trunking Rapid 80[®].

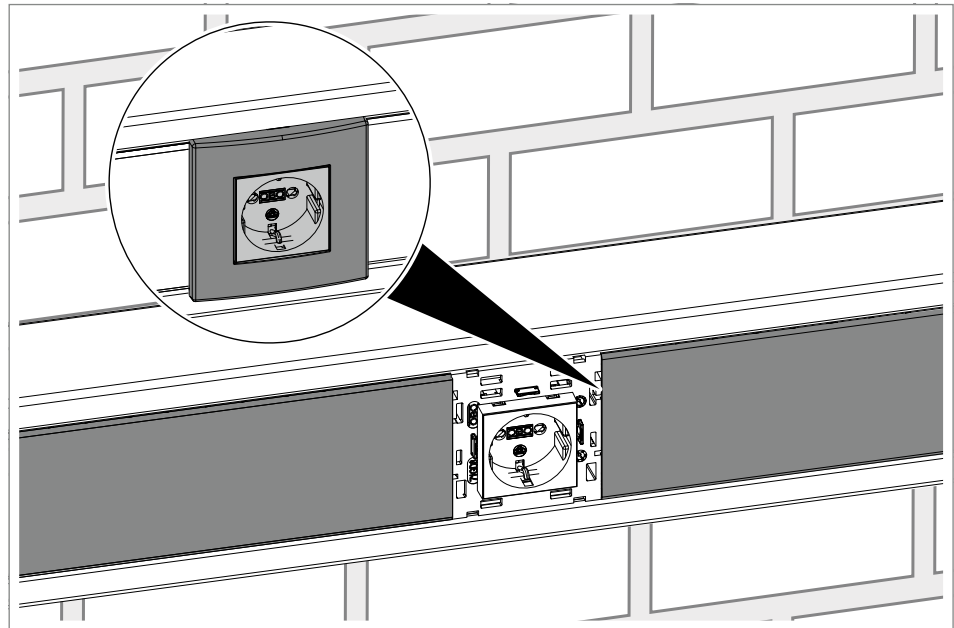

Fig. 23: Mounting the cover

4. Engage the cover ⑤ in the cover contour of the device installation trunking Rapid 80® ① and push it up to the accessory mounting box.
5. Engage the cover frame on the accessory mounting box 71GD8-2 ⑱/71GD13 ⑳.

7.2 Mounting the Modul 45 connect® socket

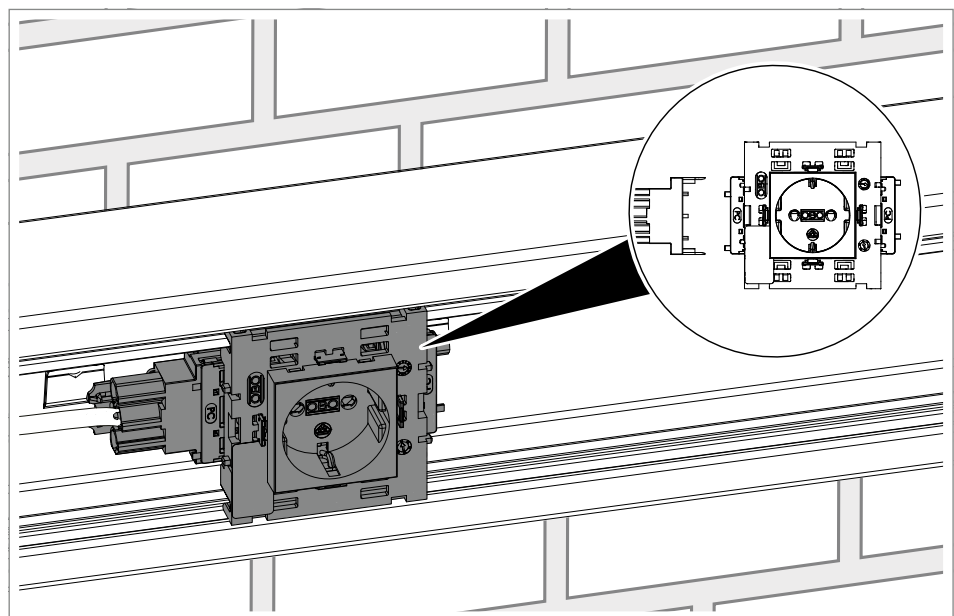

Fig. 24: Mounting the Modul 45 connect® socket

1. Connect the Modul 45 connect® socket with the Wieland connector.
2. Engage the Modul 45 connect® socket in the cover contour of the device installation trunking Rapid 80® ①.

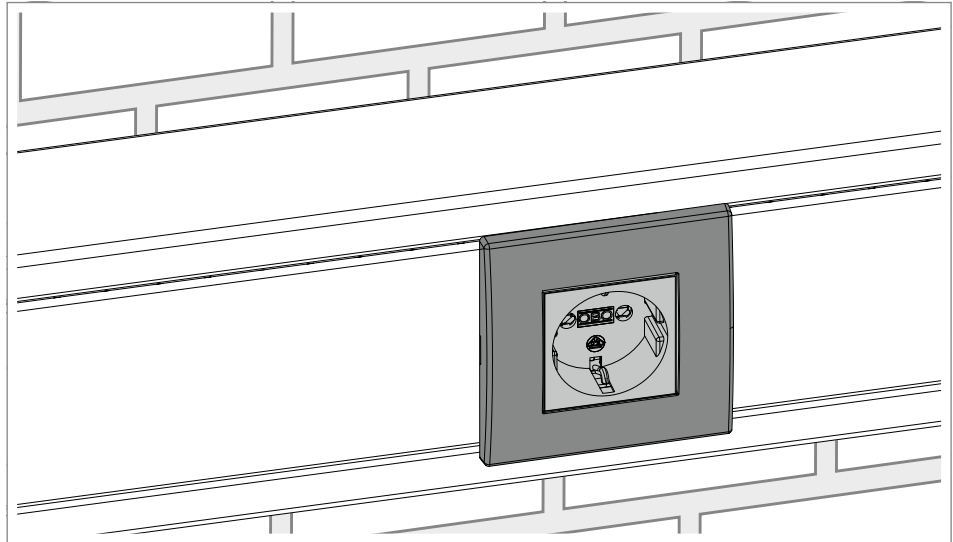

Fig. 25: Mounting the base and cover frame

3. Engage the cover ⑤ and cover frame in the cover contour of the device installation trunking Rapid 80® ①.

7.3 Mounting the support ring devices

Note!

The mounting of the double accessory mounting box takes place in the same way.

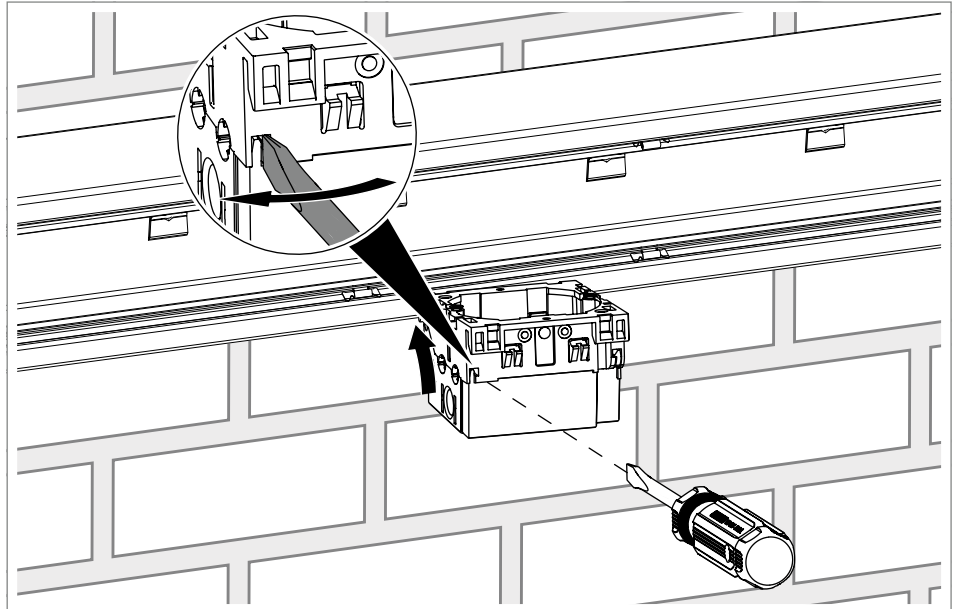

Fig. 26: Opening the accessory mounting box

1. Unlock the locking hooks with a slotted screwdriver.
2. Open the accessory mounting box 71GD6 ③/71GD7-2 ④.

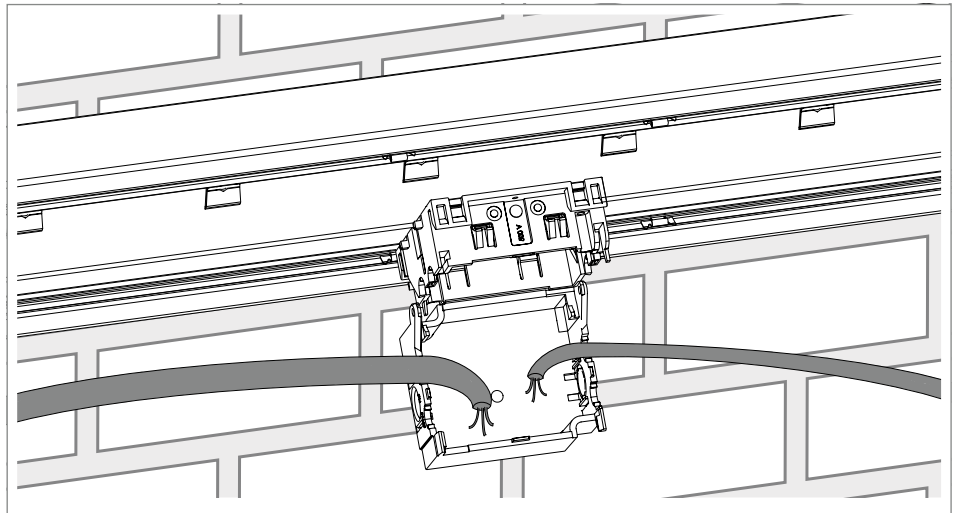

Fig. 27: Insert cables

3. Lay the insulated cable in the opened accessory mounting box 71GD6 ③/71GD7-2 ④.
4. Close the accessory mounting box 71GD6 ③/71GD7-2 ④.

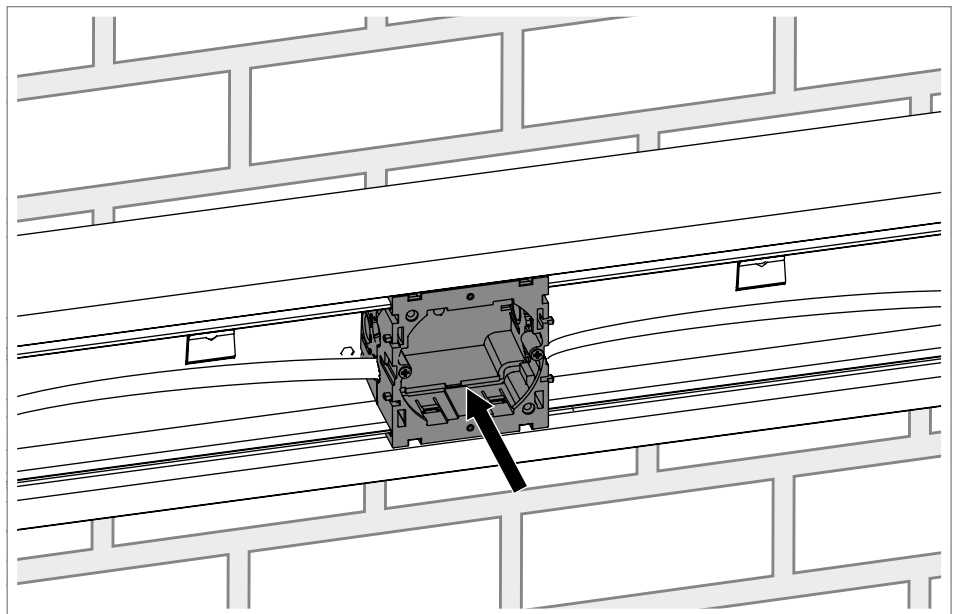

Fig. 28: Engaging the accessory mounting box

5. Engage the accessory mounting box 71GD6 ③/71GD7-2 ④ in the device installation trunking Rapid 80® ①.

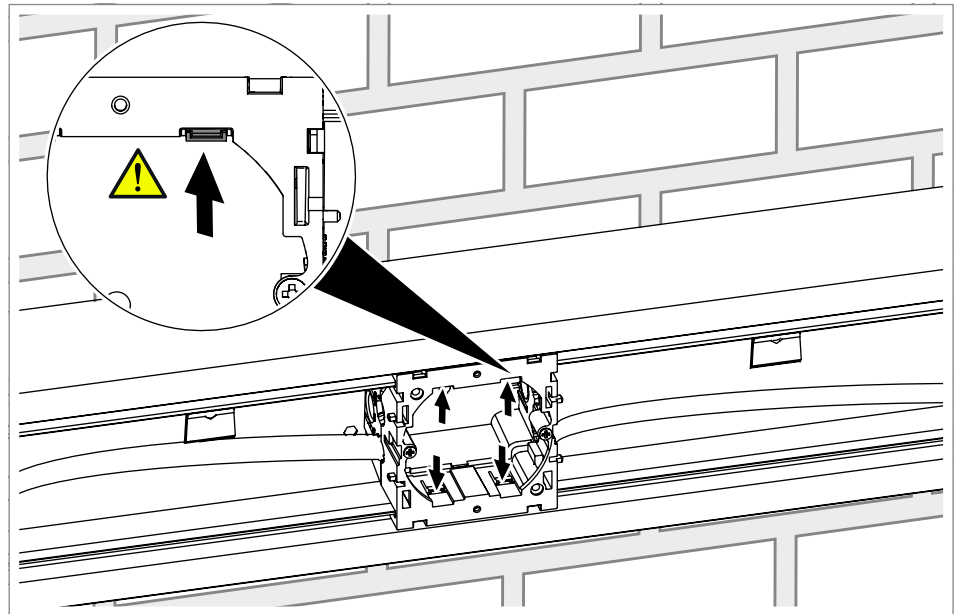

Fig. 29: Locking the accessory mounting box

6. Push the locking hooks of the accessory mounting box 71GD6 ³/71GD7-2 ⁴ under the locking contour.

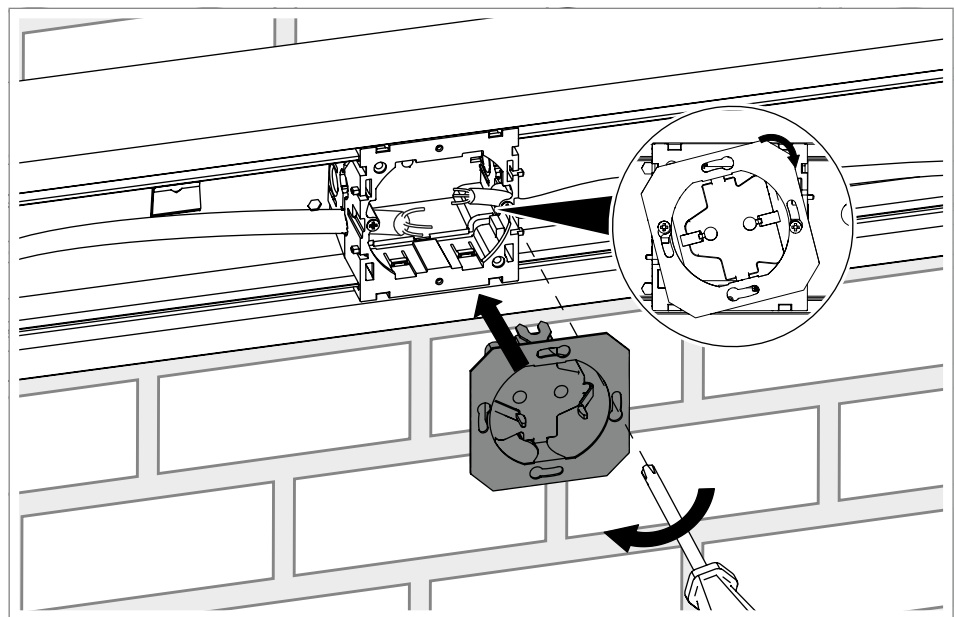

Fig. 30: Mounting the support ring

7. Connect the socket (with support ring).
8. Insert the socket.
9. Lock/turn the socket.
10. Screw the socket using the pre-mounted screws.

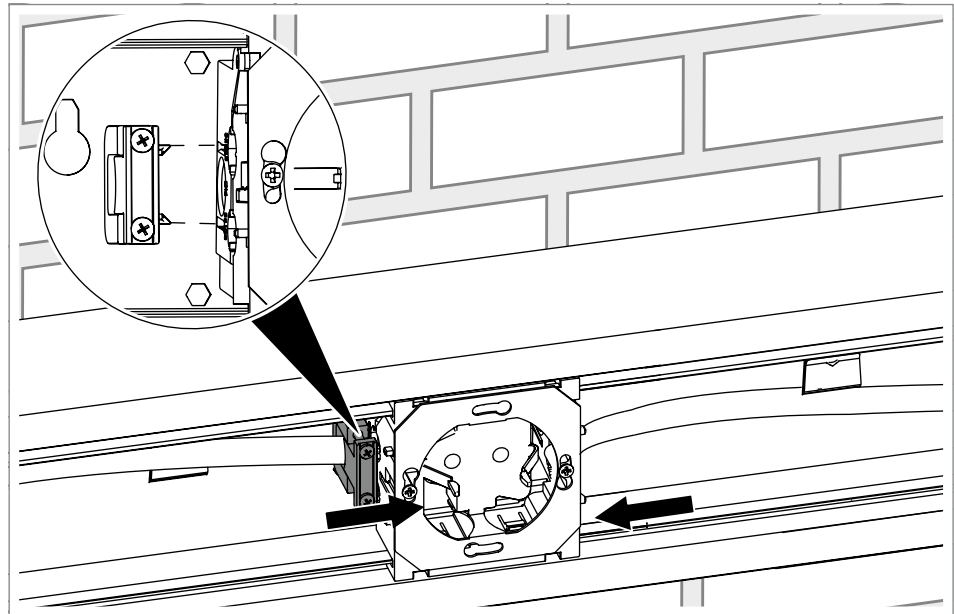

Fig. 31: Mounting the strain relief

11. Push the strain relief **21** with locking noses into the side of the accessory mounting box 71GD6 **3**/71GD7-2 **4**.

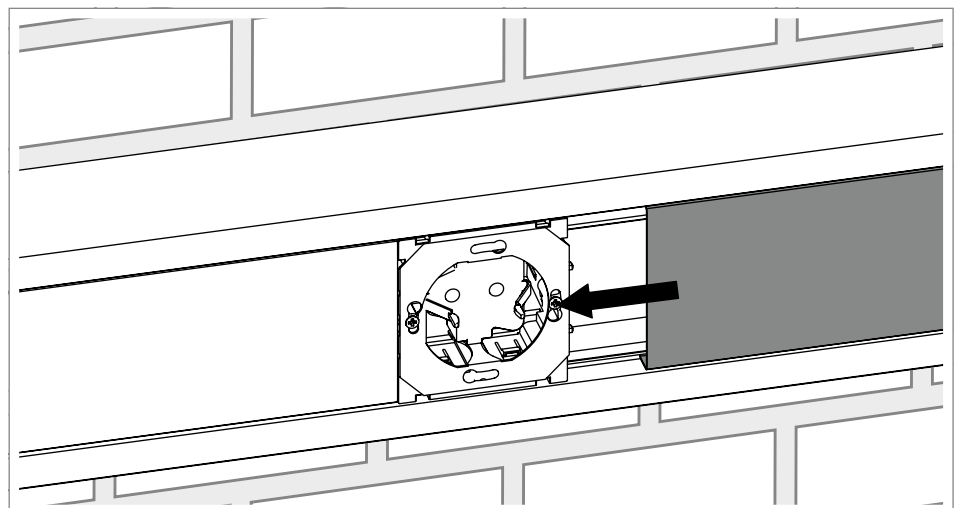

Fig. 32: Mounting the cover

12. Push the cover **5** to be flush to the edge of the accessory mounting box 71GD6 **3**/71GD7-2 **4**.

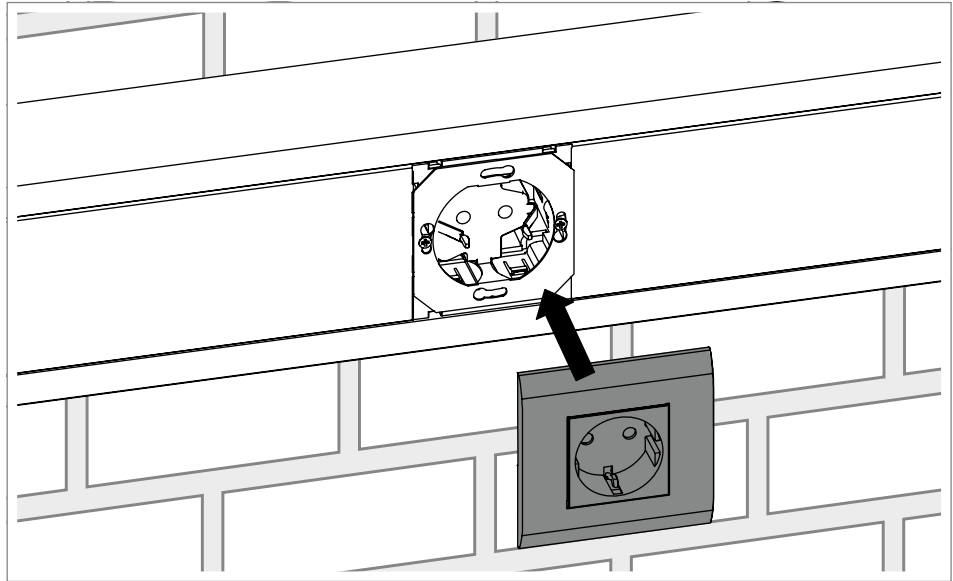

Fig. 33: Mounting the socket

13. Complete mounting of the socket (according to the manufacturer's specifications).

7.4 Mounting the CEE socket

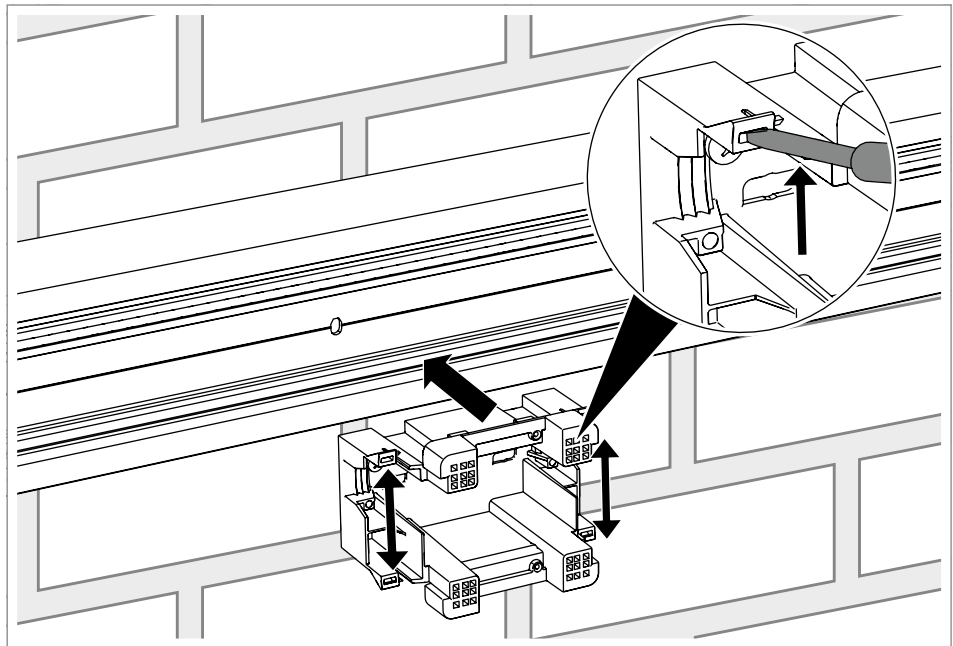

Fig. 34: Inserting the accessory mounting box 71GDCEE

1. Insert the accessory mounting box 71GDCEE ²⁶ in the device installation trunking Rapid 80® ¹.
2. Lock the device installation trunking 71GDCEE ²⁶ with the locking hooks.

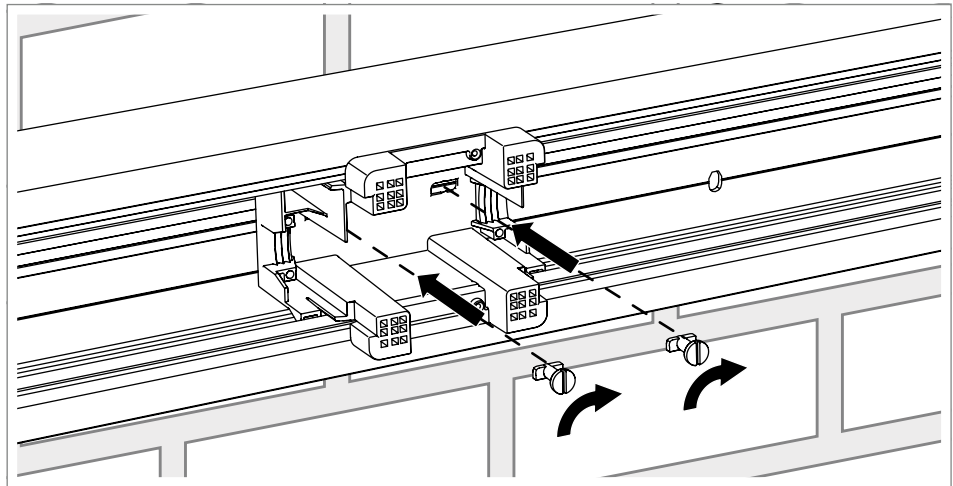

Fig. 35: Screwing in the accessory mounting box 71GDCEE

Note! *This step applies to the variant made from aluminium and plastic.*

3. Push the turn buckle through the recesses in the base of accessory mounting box 71GDCEE 26 into the C rail of the device installation trunking Rapid 80® 1.
4. Turn the turn buckle 90° to the right.

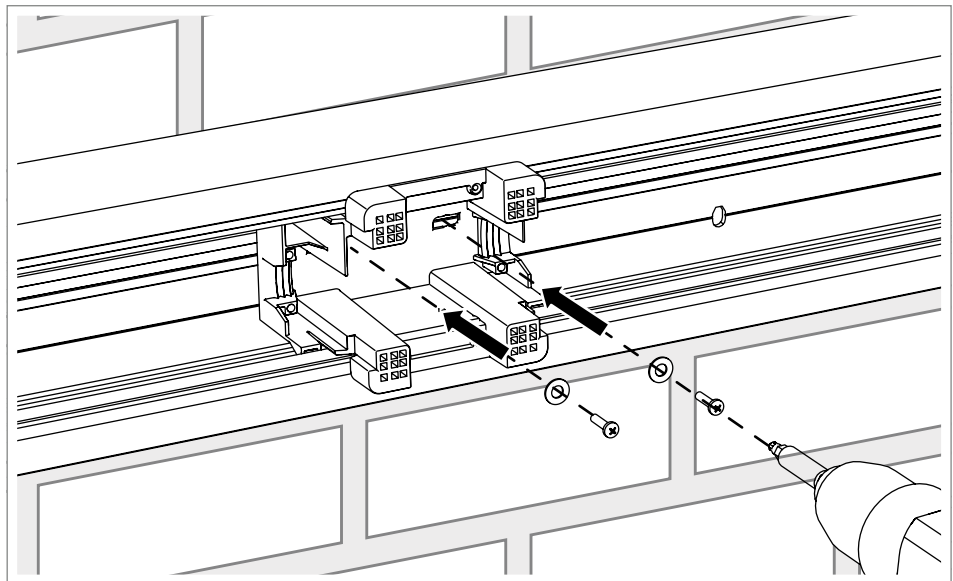

Fig. 36: Screwing in the accessory mounting box 71GDCEE

Note! *This step applies to the variant made from sheet steel.*

5. Drill holes in the wall behind at the positions of the floor recesses.

Note! *The mounting materials are not contained in the scope of delivery.*

6. Screw the accessory mounting box 71GDCEE 26 into the wall with anchors, screws and washers.

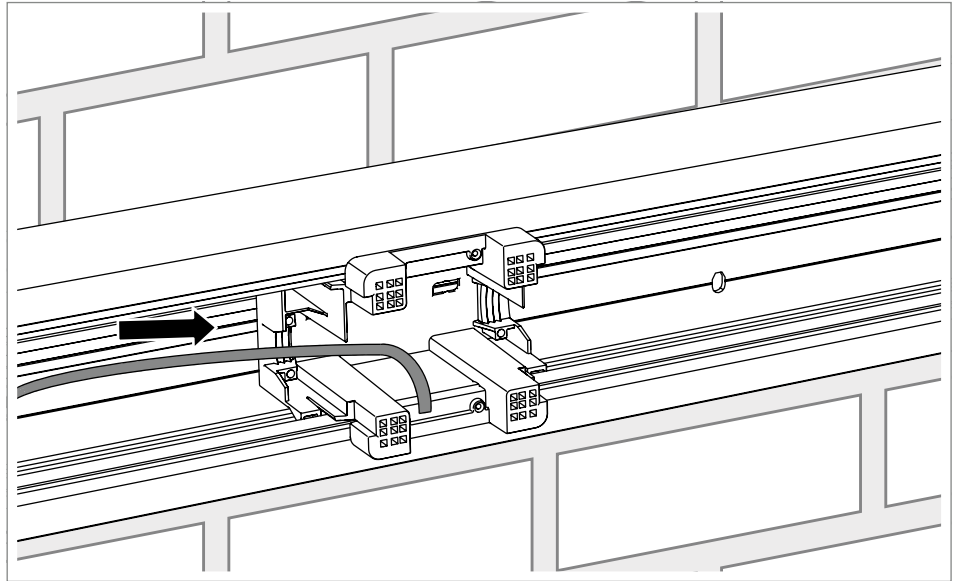

Fig. 37: Inserting cables

7. Lay the cable in the accessory mounting box 71GDCEE ²⁶.

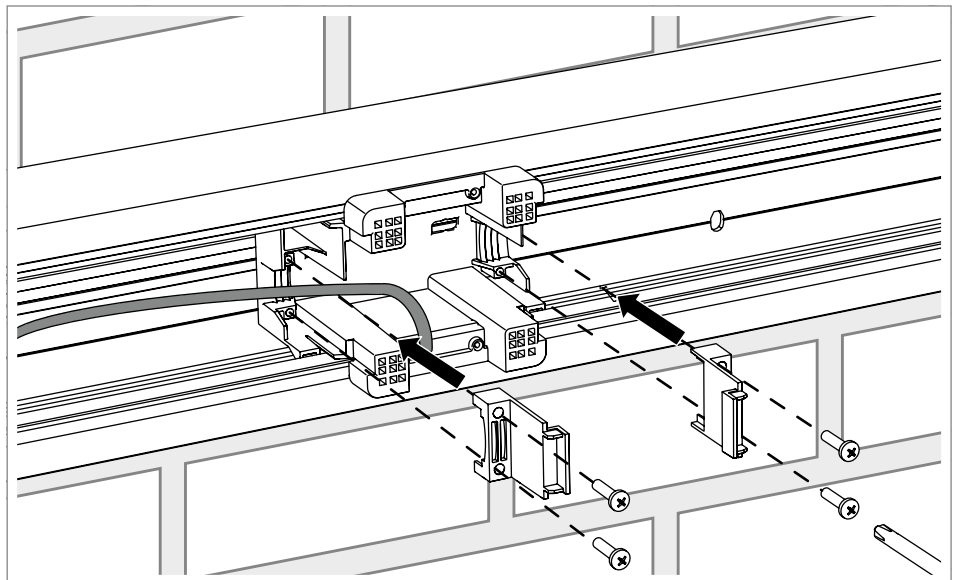

Fig. 38: Screwing in the strain relief

8. Screw both strain reliefs ²¹ tight using the supplied screws (torque: 1.2 Nm).

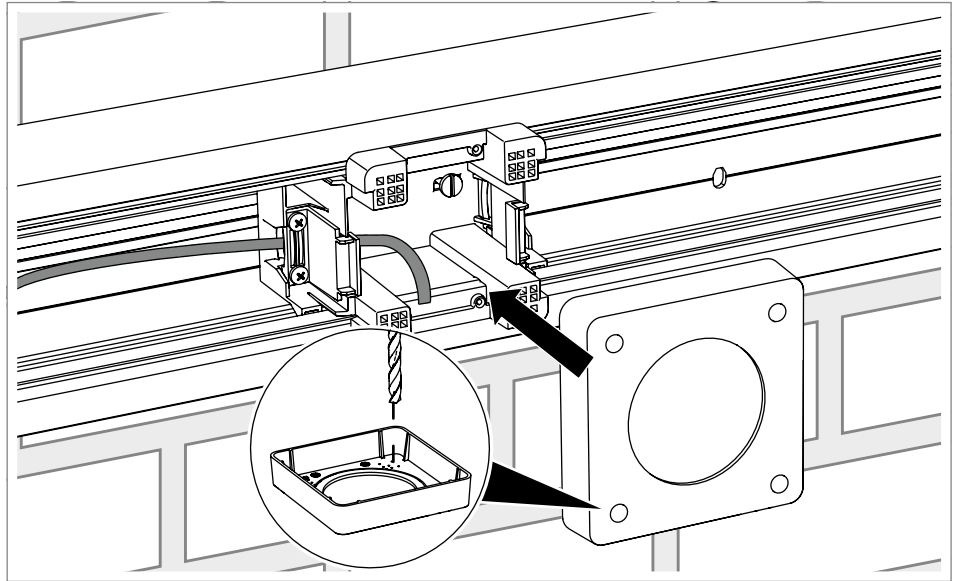

Fig. 39: Mounting the cover frame

9. Measure the drill hole spacings on the CEE socket.
10. Mark the corresponding perforations (depending on the drill hole spacing) in the interior of the cover frame.
11. Pre-drill the cover frame from within (diameter: 4.5 mm).
12. Attach the cover frame to the accessory mounting box 71GDCEE ²⁶.

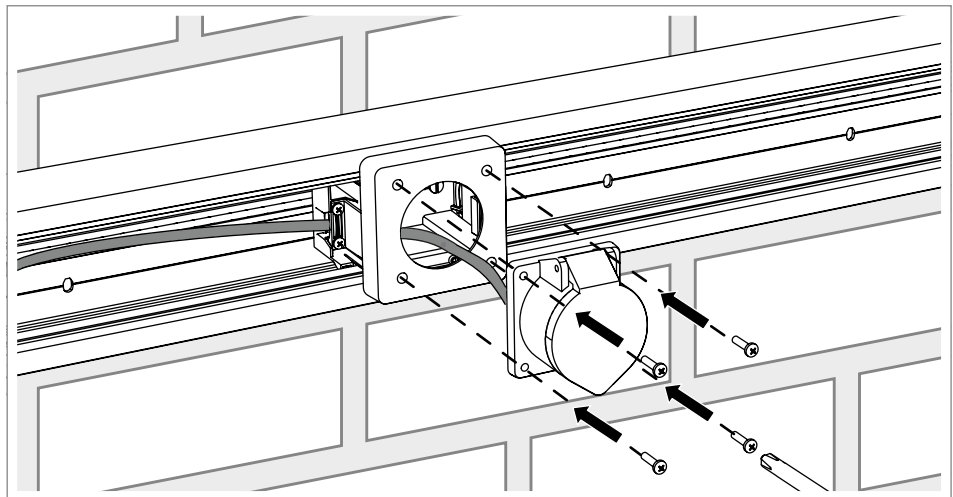

Fig. 40: Mounting the CEE socket

13. Connect the cable to the CEE socket.
14. Attach the CEE socket to the cover frame.
15. Screw the CEE socket tight using the metal screws supplied. (Torque: 1.2 Nm)

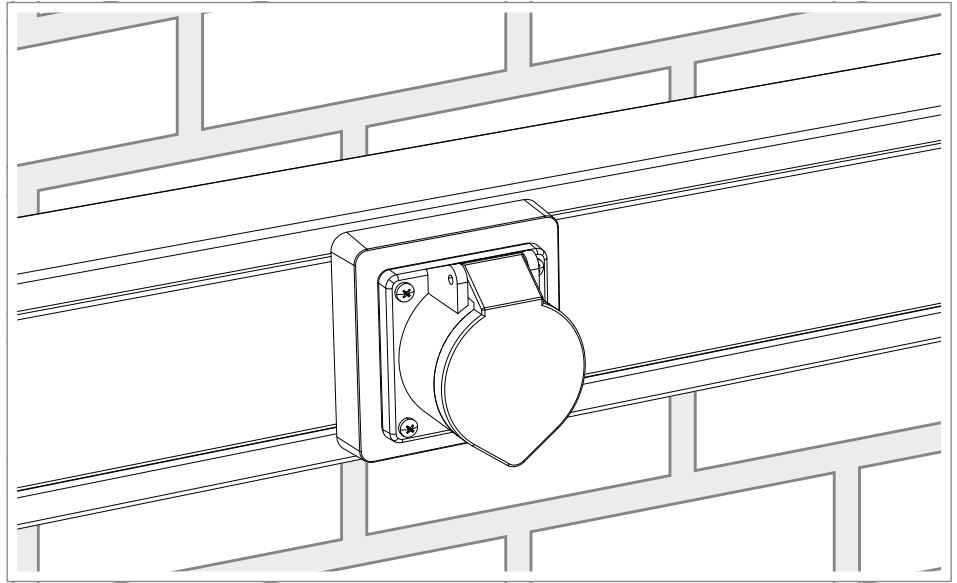

Fig. 41: Final state

8 Mounting accessories

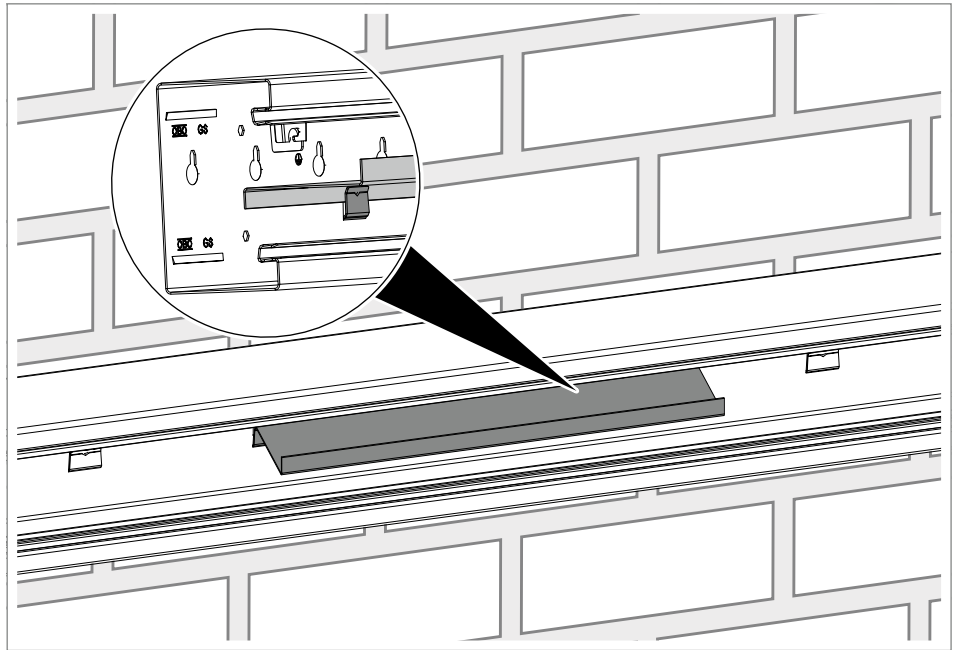

Fig. 42: Mounting the partition (device installation trunking Rapid 80® GS)

1. Engage the partition 17 in the fastening straps on the base of the device installation trunking Rapid 80® GS 1.

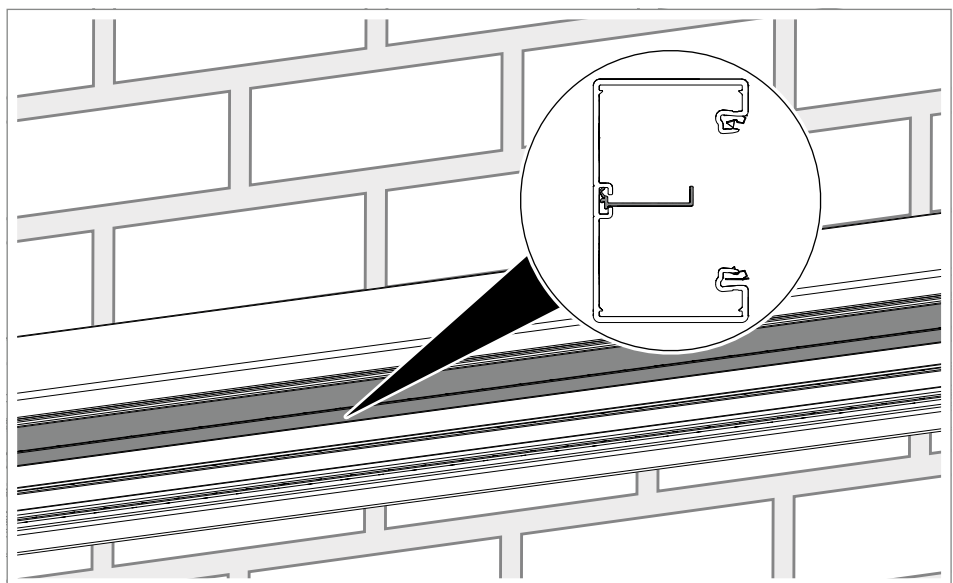

Fig. 43: Mounting the partition (device installation trunking Rapid 80® GK/GA)

2. Engage the partition 17 in the C profile rail on the base of the device installation trunking Rapid 80® GK/GA 1.

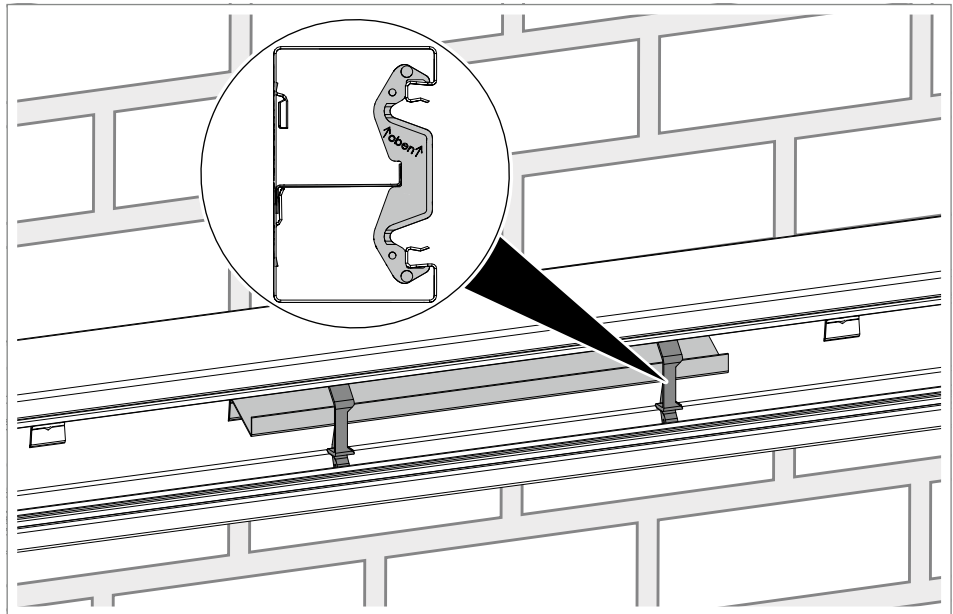

Fig. 44: Mounting the duct clamps

Note!

The duct clamps are installed for all materials.

- Engage the duct clamp 18 on the partition 17 and in the cover contour of the device installation trunking Rapid 80® 1.

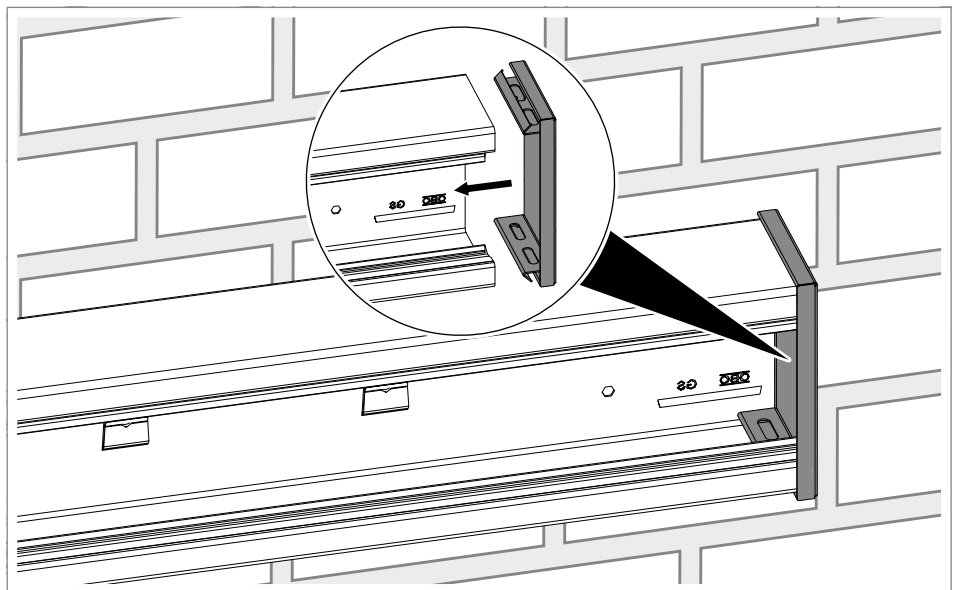

Fig. 45: Mounting the end piece (device installation trunking Rapid 80® GS)

- Engage the end piece on the end of the device installation trunking Rapid 80® GS 1.

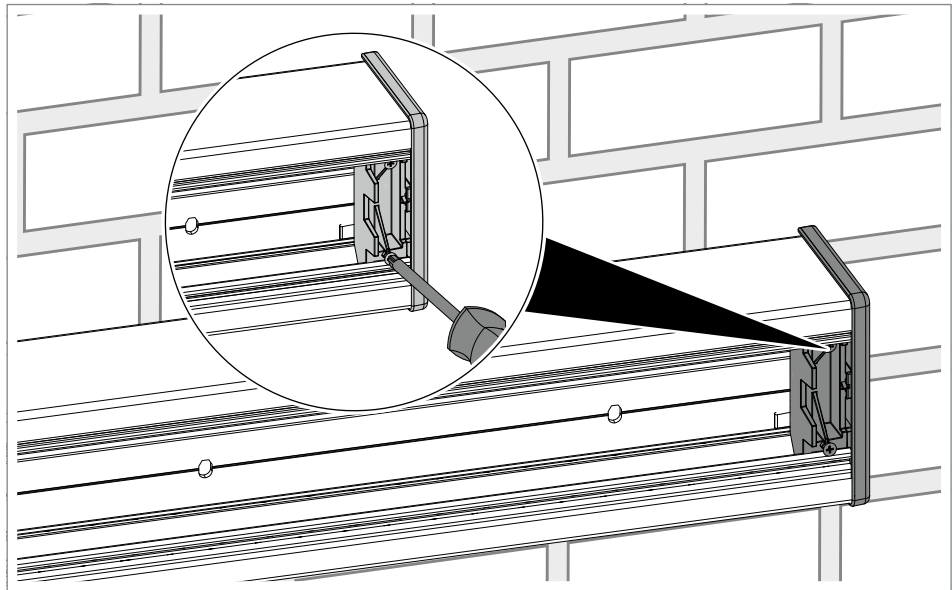

Fig. 46: Mounting the end piece (device installation trunking Rapid 80® GK)

Note!

The end piece consists of a fastening element and a screen. The screen guides are suitable for each trunking type (symmetrical, asymmetrical or duoduct) as well as left and right end pieces.

5. Mount the end piece fastening element on the end piece ¹⁶. The pictograms on the screen help to select the appropriate guide.
6. Place the pre-mounted end piece on the device installation trunking Rapid 80® ¹ and fix it to the device installation trunking Rapid 80® GK ¹ using the two bolts.

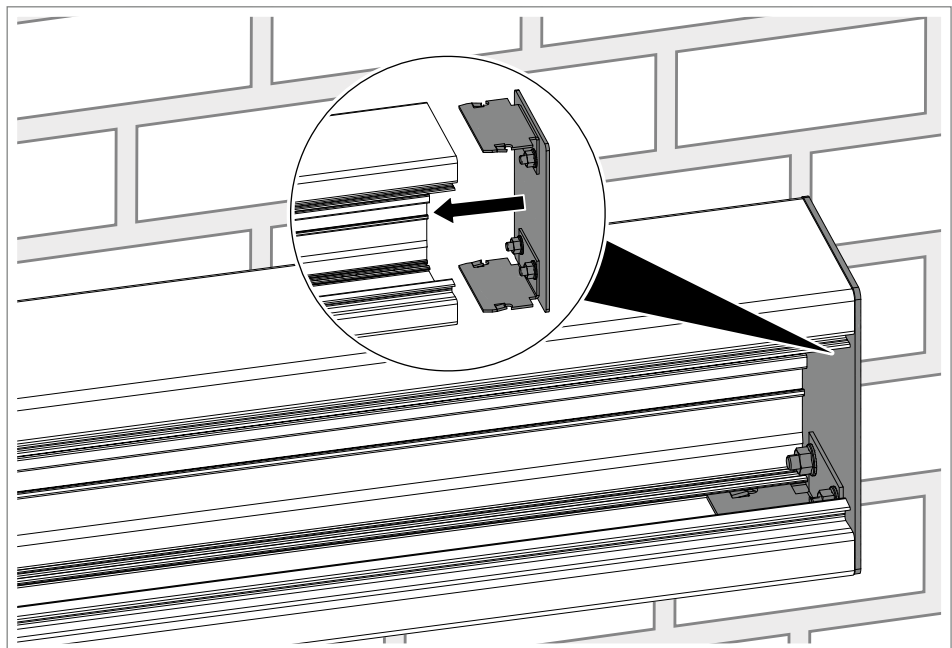

Fig. 47: Mounting the end piece (device installation trunking Rapid 80® GA)

7. Engage the end piece on the end of the device installation trunking Rapid 80® GA ¹.

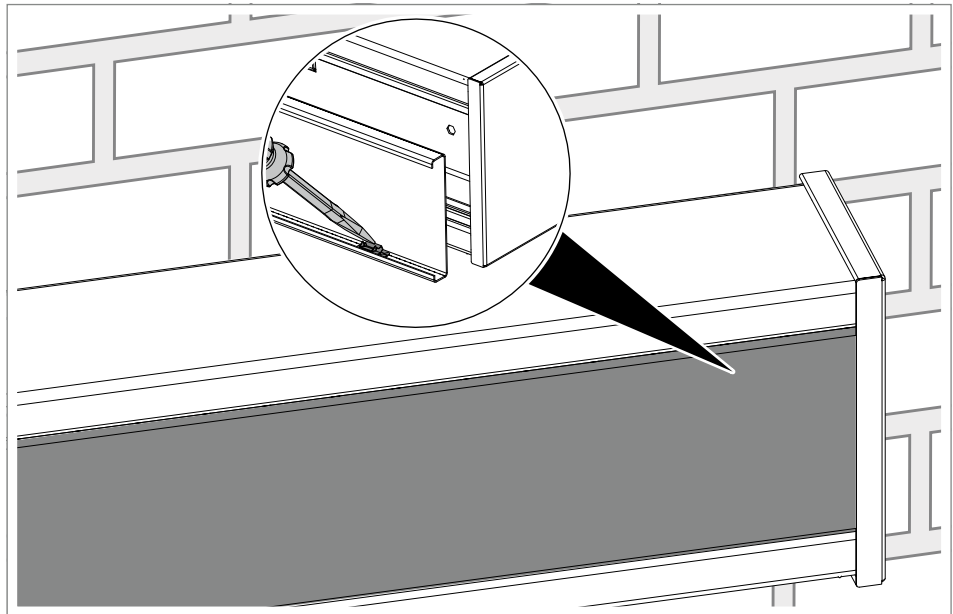

Fig. 48: Mounting the cover (device installation trunking Rapid 80® GA/GS)

Note!

The self-contacting cover earthing guarantees continuous protection without any additional wiring. The locking brackets are pre-mounted in the cover. Locking bracket for the mechanical and electrical connection of trunking covers and trunking bases.

8. With cut covers, install locking brackets 22. They must be mounted at a distance of min. 50 mm from the end of the cover 5.
9. Engage the cover 5 in the device installation trunking Rapid 80® 1.

8.1 Earthing the device installation trunking Rapid 80®

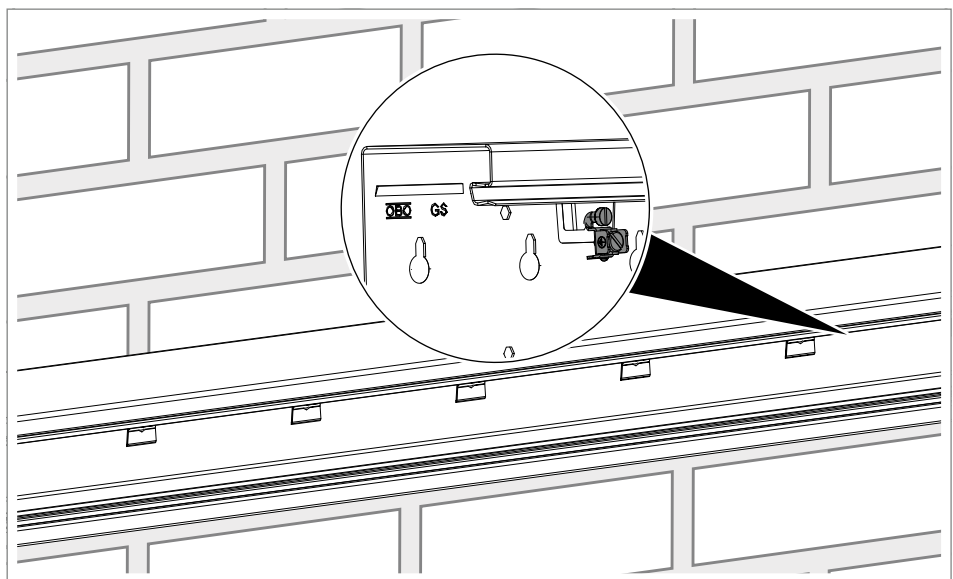

Fig. 49: Earthing the device installation trunking Rapid 80® (device installation trunking Rapid 80® GS)

1. Turn the protective conductor connection bracket 23 into the appropriate recess in the device installation trunking Rapid 80® 1 and

fasten it using a screwdriver.

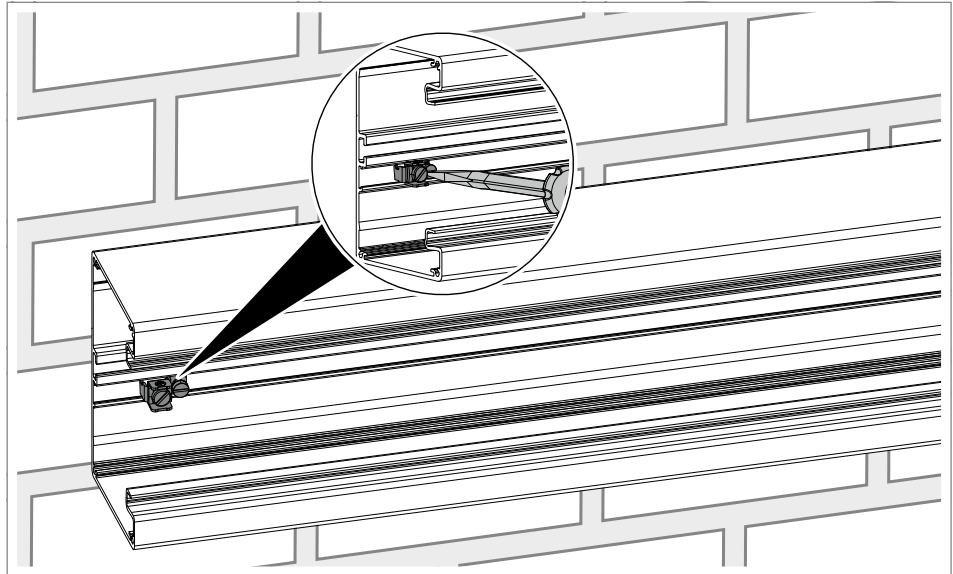

Fig. 50: Earthing the device installation trunking Rapid 80® (device installation trunking Rapid 80® GA)

2. Push the protective conductor connection bracket ²³ into the fastening track (1.6 x 11 mm) in the device installation trunking Rapid 80® ¹.
3. Tighten the fastening screw (torque: 1.2 Nm).

8.2 Mounting wall penetrations/noise limit barriers

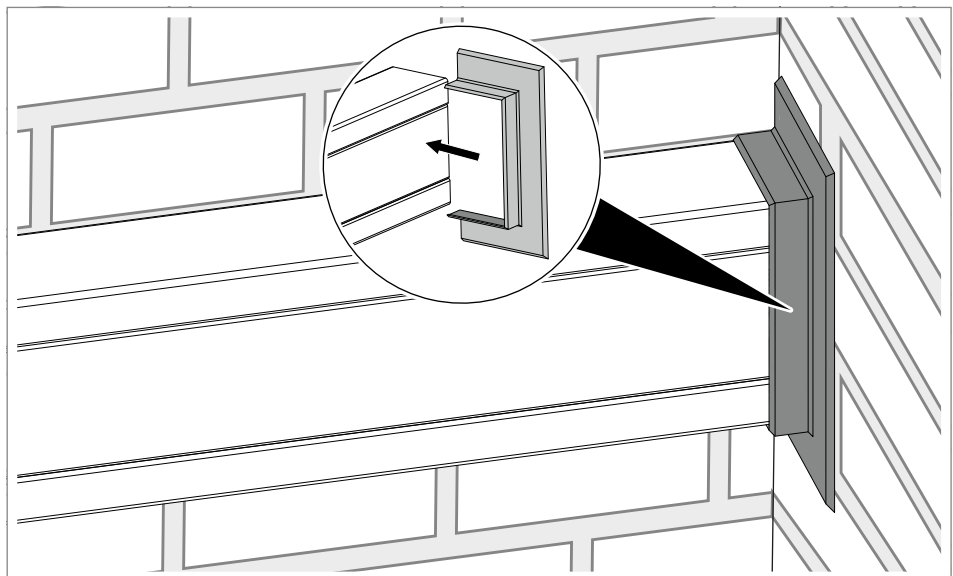

Fig. 51: Mounting the wall end piece (device installation trunking Rapid 80® GA/GK/GS)

Note!

During mounting, the substrate must be free of dust and grease.

1. Fix the wall end piece with the pre-mounted adhesive tape on the device installation trunking Rapid 80® ¹.

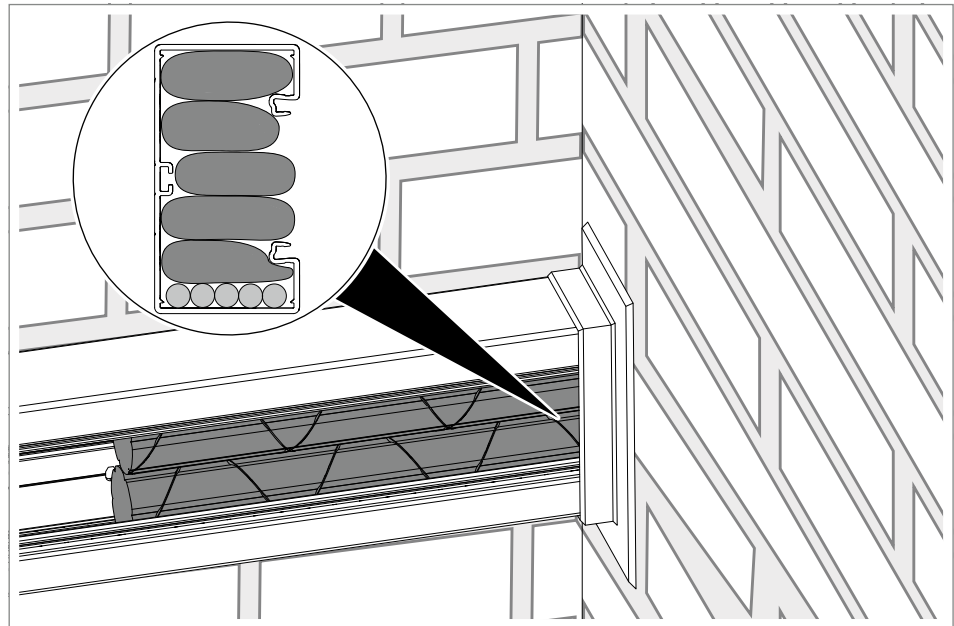

Fig. 52: Mounting the noise limit barrier (device installation trunking Rapid 80® GA/GK/GS)

For wall penetrations, measures may have to be taken to minimise noise transmission (airborne noise), e.g. by inserting noise limit barriers into the device installation trunking Rapid 80®.

Note! *The attenuation is a maximum of 40 dB. The exact value depends on the proportion of cables inserted and the noise insulation used.*

Note! *Noise limit barriers are not considered a fire protection measure. To ensure fire protection when leading trunking, ducts or cables through fire protection walls, fire insulation meeting standards with general construction approval must be used.*

1. Insert the noise limit barrier in the device installation trunking Rapid 80® ①. Refer to the following table for the number of noise limit barriers to use:

Trunking width	Trunking depth 70 mm	Trunking depth 90 mm
Width 110 mm	12	15
Width 130 mm	13	17
Width 170 mm	15	20
Width 210 mm	19	24

9 Caring for the device installation trunking Rapid 80®

The visible surfaces of device installation trunking made from plastic, sheet steel and aluminium are masked with protective film at the factory and packaged in cardboard to prevent surface contamination during the construction phase.

When removing the protective film and removing the product from the slipcase, the plastic trunking may become electrostatically charged. This electrostatic charge can lead to increased dirt adhesion on the surface.

Antistatic cleaners and sprays prevent increased dirt adhesion and clean the surface.

10 Maintaining the device installation trunking Rapid 80®

The requirements for maintaining device installation trunking vary depending on the mounting location and use.

Observe the following basic rules:

- If the device installation trunking is subjected to dynamic loads, e.g. when mounted directly to machine parts or conveyor systems, shaking motions may loosen the mounting elements used. In this case, check the screw connections and the stability of the trunking system regularly.
- If only static loads occur, the trunking system does not have to be maintained.

11 Dismantling the device installation trunking Rapid 80®

Dismantling of all the elements of the device installation trunking Rapid 80® takes place in the reverse order to mounting.

12 Disposing of the device installation trunking Rapid 80®



Comply with the local waste disposal regulations.

- Metallic parts: As scrap metal
- Plastic parts: As plastic
- Packaging: As household waste (depending on packaging type)

13 Technical data

13.1 Device installation trunking Rapid 80®

Type	Item no.	Dimensions (H x W x L)	Material
GK-70110RW	6274300	70x110x2,000	Polyvinylchloride
GK-70110CW	6274301	70x110x2,000	Polyvinylchloride
GK-70110LGR	6274302	70x110x2,000	Polyvinylchloride
GK-70110GR	6274306	70x110x2,000	Polyvinylchloride
GK-70130RW	6270444	70x130x3,000	Polyvinylchloride
GK-70130CW	6270445	70x130x3,000	Polyvinylchloride
GK-70130RW	6274500	70x130x2,000	Polyvinylchloride
GK-70130CW	6274501	70x130x2,000	Polyvinylchloride
GK-70130LGR	6274502	70x130x2,000	Polyvinylchloride
GK-70130SW	6274504	2,000x130x70	Polyvinylchloride
GK-70130GR	6274506	70x130x2,000	Polyvinylchloride
GK-70170RW	6274700	70x170x2,000	Polyvinylchloride
GK-70170CW	6274701	70x170x2,000	Polyvinylchloride
GK-70170LGR	6274702	70x170x2,000	Polyvinylchloride
GK-70170GR	6274706	70x170x2,000	Polyvinylchloride
GKH-70130RW	6114200	70x130x2,000	Polycarbonate/acrylonitrile butadiene styrene
GKH-70170RW	6114300	70x170x2,000	Polycarbonate/acrylonitrile butadiene styrene
GA-S70110RW	6279200	70x110x2,000	Aluminium
GA-S70110EL	6279203	70x110x2,000	Aluminium
GA-S70130RW	6279300	70x130x2,000	Aluminium
GA-S70130EL	6279303	70x130x2,000	Aluminium
GA-S90130RW	6276900	90x130x2,000	Aluminium
GA-S90130EL	6276903	90x130x2,000	Aluminium
GA-S70170RW	6279100	70x170x2,000	Aluminium
GA-S70170EL	6279103	70x170x2,000	Aluminium
GA-A70170RW	6279400	70x170x2,000	Aluminium
GA-A70170EL	6279403	70x170x2,000	Aluminium
GA-A90170RW	6279500	90x170x2,000	Aluminium
GA-A90170EL	6279503	90x170x2,000	Aluminium
GA-D90210RW	6279600	90x210x2,000	Aluminium
GA-D90210EL	6279603	90x210x2,000	Aluminium

Type	Item no.	Dimensions (H x W x L)	Material
GS-S70110RW	6277000	70x110x2,000	Steel
GS-S70110FS	6277003	70x110x2,000	Steel
GS-S70110RW	6277007	70x110x3,000	Steel
GS-S90110RW	6277100	90x110x2,000	Steel
GS-S70130RW	6277200	70x130x2,000	Steel
GS-S70130FS	6277203	70x130x2,000	Steel
GS-S70130RW	6277207	70x130x3,000	Steel
GS-A70130FS	6277403	70x130x2,000	Steel
GS-A70130RW	6277400	70x130x2,000	Steel
GS-S90130RW	6277300	90x130x2,000	Steel
GS-A90130RW	6277500	90x130x2,000	Steel
GS-S70170FS	6277603	70x170x2,000	Steel
GS-S70170RW	6277600	70x170x2,000	Steel
GS-S70170RW	6277607	70x170x3,000	Steel
GS-A70170RW	6277800	70x170x2,000	Steel
GS-A70170FS	6277803	70x170x2,000	Steel
GS-A70170RW	6277807	70x170x3,000	Steel
GS-D70170RW	6278200	70x170x2,000	Steel
GS-S90170RW	6277700	90x170x2,000	Steel
GS-A90170RW	6277900	90x170x2,000	Steel
GS-D90170RW	6278300	90x170x2,000	Steel
GS-A70210RW	6278000	70x210x2,000	Steel
GS-A70210RW	6278007	70x210x3,000	Steel
GS-D70210RW	6278400	70x210x2,000	Steel
GS-A90210RW	6278100	90x210x2,000	Steel
GS-D90210RW	6278500	90x210x2,000	Steel
GEK-SA133110RW	6282700	133x110x2,000	Steel

Tab. 2: Technical data: Device installation trunking Rapid 80®

13.2 Fittings

13.2.1 Internal corner

Type	Item no.	Dimensions (H x W x L)	Material
GA-AI70170EL	6279443	70x170x300	Aluminium

Type	Item no.	Dimensions (H x W x L)	Material
GA-DI90210EL	6279643	90x210x300	Aluminium
GA-SI90130EL	6276943	90x130x300	Aluminium
GA-SI70170EL	6279143	70x170x300	Aluminium
GA-SI70110EL	6279243	70x110x300	Aluminium
GA-SI70130EL	6279343	70x130x300	Aluminium
GEK-SAIS-133110RW	6282740	133x110x300	Steel
GS-AI70130RW	6277440	70x130x128	Steel
GS-AI90130RW	6277540	90x130x148	Steel
GS-AI70170RW	6277840	70x170x128	Steel
GS-AI90170RW	6277940	90x170x148	Steel
GS-AI70210RW	6278050	70x210x128	Steel
GS-AI90210RW	6278140	90x210x148	Steel
GS-DI70170RW	6278240	70x170x128	Steel
GS-DI90170RW	6278340	90x170x148	Steel
GS-DI70210RW	6278440	70x210x128	Steel
GS-DI90210RW	6278540	90x210x148	Steel
GS-SI70110RW	6277040	70x110x128	Steel
GS-SI90110RW	6277140	90x110x148	Steel
GS-SI70130RW	6277240	70x130x128	Steel
GS-SI90130RW	6277340	90x130x148	Steel
GS-SI70170RW	6277640	70x170x128	Steel
GS-SI90170RW	6277740	90x170x148	Steel
GK-I70110RW	6274340	70x110 mm	Polyvinylchloride
GK-I70110CW	6274341	70x110 mm	Polyvinylchloride
GK-I70110LGR	6274342	70x110 mm	Polyvinylchloride
GK-I70110GR	6274346	70x110 mm	Polyvinylchloride
GK-I70130RW	6274540	70x130 mm	Polyvinylchloride
GK-I70130CW	6274541	70x130 mm	Polyvinylchloride
GK-I70130LGR	6274542	70x130 mm	Polyvinylchloride
GK-I70130GR	6274546	70x130 mm	Polyvinylchloride
GK-I70170RW	6274740	70x170 mm	Polyvinylchloride
GK-I70170CW	6274741	70x170 mm	Polyvinylchloride
GK-I70170LGR	6274742	70x170 mm	Polyvinylchloride

Type	Item no.	Dimensions (H x W x L)	Material
GK-I70170GR	6274746	70x170 mm	Polyvinylchloride
GA-SI70110RW	6279240	70x110x300	Aluminium
GA-SI70130RW	6279340	70x130x300	Aluminium
GA-SI90130RW	6276940	90x130x300	Aluminium
GA-SI70170RW	6279140	70x170x300	Aluminium
GA-AI70170RW	6279440	70x170x300	Aluminium
GA-AI90170RW	6279540	90x170x300	Aluminium
GA-AI90170EL	6279543	90x170x300	Aluminium
GA-DI90210RW	6279640	90x210x300	Aluminium
GK-IS53100RW	6113060	175x175x100	Polyvinylchloride
GK-IS53100LGR	6113062	175x175x100	Polyvinylchloride
GK-IS53130RW	6113240	175x175x130	Polyvinylchloride
GK-IS53130LGR	6113242	175x175x130	Polyvinylchloride
GK-IS53165RW	6113430	175x175x165	Polyvinylchloride
GK-IS53165LGR	6113432	175x175x165	Polyvinylchloride
GKH-I70130RW	6114260	70x130	Polycarbonate/acrylonitrile butadiene styrene
GKH-I70170RW	6114360	70x170	Polycarbonate/acrylonitrile butadiene styrene
GK-IH70110RW	6274240	70x110 mm	Polycarbonate/acrylonitrile butadiene styrene
GK-IH70110CW	6274241	70x110 mm	Polycarbonate/acrylonitrile butadiene styrene
GK-IH70110LGR	6274282	70x110 mm	Polycarbonate/acrylonitrile butadiene styrene
GK-IH70130RW	6274440	70x130 mm	Polycarbonate/acrylonitrile butadiene styrene
GK-IH70130CW	6274441	70x130 mm	Polycarbonate/acrylonitrile butadiene styrene
GK-IH70130LGR	6274442	70x130 mm	Polycarbonate/acrylonitrile butadiene styrene
GK-IH70130SW	6274443	70x130	Polycarbonate/acrylonitrile butadiene styrene
GK-IH70170RW	6274640	70x170 mm	Polycarbonate/acrylonitrile butadiene styrene
GK-IH70170CW	6274641	70x170 mm	Polycarbonate/acrylonitrile butadiene styrene
GK-IH70170LGR	6274642	70x170 mm	Polycarbonate/acrylonitrile butadiene styrene
GK-IH70210RW	6273940	70x210 mm	Polycarbonate/acrylonitrile butadiene styrene
GK-IH70210LGR	6273942	70x210 mm	Polycarbonate/acrylonitrile butadiene styrene

Tab. 3: Technical data: Internal corner

13.2.2 External corner

Type	Item no.	Dimensions (H x W x L)	Material
GA-AA70170EL	6279413	70x170x300	Aluminium
GA-DA90210EL	6279613	90x210x300	Aluminium
GA-SA90130EL	6276913	90x130x300	Aluminium
GA-SA70170EL	6279113	70x170x300	Aluminium
GA-SA70110EL	6279213	70x110x300	Aluminium
GA-SA70130EL	6279313	70x130x300	Aluminium
GEK-SAA133110RW	6282710	133x110x300	Steel
GS-DA70210RW	6278410	70x210x300	Steel
GS-DA90210RW	6278510	90x210x300	Steel
GS-AA70130RW	6277410	70x130x300	Steel
GS-AA90130RW	6277510	90x130x300	Steel
GS-AA70170RW	6277810	70x170x300	Steel
GS-AA90170RW	6277910	90x170x300	Steel
GS-AA70210RW	6278010	70x210x300	Steel
GS-AA90210RW	6278110	90x210x300	Steel
GS-DA70170RW	6278210	70x170x300	Steel
GS-DA90170RW	6278310	90x170x300	Steel
GS-SA70110RW	6277010	70x110x300	Steel
GS-SA90110RW	6277110	90x110x300	Steel
GS-SA70130RW	6277210	70x130x300	Steel
GS-SA90130RW	6277310	90x130x300	Steel
GS-SA70170RW	6277610	70x170x300	Steel
GS-SA90170RW	6277710	90x170x300	Steel
GK-A70110RW	6274310	70x110 mm	Polyvinylchloride
GK-A70110CW	6274311	70x110 mm	Polyvinylchloride
GK-A70110LGR	6274312	70x110 mm	Polyvinylchloride
GK-A70110GR	6274316	70x110 mm	Polyvinylchloride
GK-A70130RW	6274510	70x130 mm	Polyvinylchloride
GK-A70130CW	6274511	70x130 mm	Polyvinylchloride
GK-A70130LGR	6274512	70x130 mm	Polyvinylchloride
GK-A70130GR	6274516	70x130 mm	Polyvinylchloride
GK-A70170RW	6274710	70x170 mm	Polyvinylchloride

Type	Item no.	Dimensions (H x W x L)	Material
GK-A70170CW	6274711	70x170 mm	Polyvinylchloride
GK-A70170LGR	6274712	70x170 mm	Polyvinylchloride
GK-A70170GR	6274716	70x170 mm	Polyvinylchloride
GA-SA70110RW	6279210	70x110x300	Aluminium
GA-SA90130RW	6276910	90x130x300	Aluminium
GA-SA70130RW	6279310	70x130x300	Aluminium
GA-SA70170RW	6279110	70x170x300	Aluminium
GA-AA70170RW	6279410	70x170x300	Aluminium
GA-AA90170RW	6279510	90x170x300	Aluminium
GA-AA90170EL	6279513	90x170x300	Aluminium
GA-DA90210RW	6279610	90x210x300	Aluminium
GKH-A70130RW	6114220	70x130	Polycarbonate/acrylonitrile butadiene styrene
GKH-A70170RW	6114320	70x170	Polycarbonate/acrylonitrile butadiene styrene
GK-AH70110RW	6274210	70x110 mm	Polycarbonate/acrylonitrile butadiene styrene
GK-AH70110CW	6274211	70x110 mm	Polycarbonate/acrylonitrile butadiene styrene
GK-AH70110LGR	6274212	70x110 mm	Polycarbonate/acrylonitrile butadiene styrene
GK-AH70130RW	6274410	70x130 mm	Polycarbonate/acrylonitrile butadiene styrene
GK-AH70130CW	6274411	70x130 mm	Polycarbonate/acrylonitrile butadiene styrene
GK-AH70130LGR	6274412	70x130 mm	Polycarbonate/acrylonitrile butadiene styrene
GK-AH70130SW	6274413	70x130	Polycarbonate/acrylonitrile butadiene styrene
GK-AH70170RW	6274610	70x170 mm	Polycarbonate/acrylonitrile butadiene styrene
GK-AH70170CW	6274611	70x170 mm	Polycarbonate/acrylonitrile butadiene styrene
GK-AH70170LGR	6274612	70x170 mm	Polycarbonate/acrylonitrile butadiene styrene
GK-AH70210RW	6273910	70x210 mm	Polycarbonate/acrylonitrile butadiene styrene

Tab. 4: Technical data: External corner

13.2.3 Flat angle

Type	Item no.	Dimensions (H x W x L)	Material
GK-F70110RW	6274320	70x110 mm	Polyvinylchloride
GK-F70110CW	6274321	70x110 mm	Polyvinylchloride
GK-F70110LGR	6274322	70x110 mm	Polyvinylchloride

Type	Item no.	Dimensions (H x W x L)	Material
GK-F70110GR	6274326	70x110 mm	Polyvinylchloride
GK-F70130RW	6274520	70x130 mm	Polyvinylchloride
GK-F70130CW	6274521	70x130 mm	Polyvinylchloride
GK-F70130LGR	6274522	70x130 mm	Polyvinylchloride
GK-F70130GR	6274526	70x130 mm	Polyvinylchloride
GK-F70170RW	6274720	70x170 mm	Polyvinylchloride
GK-F70170CW	6274721	70x170 mm	Polyvinylchloride
GK-F70170LGR	6274722	70x170 mm	Polyvinylchloride
GK-F70170GR	6274726	70x170 mm	Polyvinylchloride
GA-AFF70170EL	6279433	70x170x300	Aluminium
GA-AFS70170EL	6279423	70x170x300	Aluminium
GA-DF90210EL	6279623	90x210x300	Aluminium
GA-SF90130EL	6276923	90x130x300	Aluminium
GA-SF70170EL	6279123	70x170x300	Aluminium
GA-SF70110EL	6279223	70x110x300	Aluminium
GA-SF70130EL	6279323	70x130x300	Aluminium
GEK-SAF-F133110RW	6282730	133x110x300	Steel
GEK-SAFS-133110RW	6282720	133x110x300	Steel
GS-AFF70130RW	6277430	70x130x300	Steel
GS-AFF90130RW	6277530	90x130x300	Steel
GS-AFF70170RW	6277830	70x170x300	Steel
GS-AFF90170RW	6277930	90x170x300	Steel
GS-AFF70210RW	6278030	70x210x300	Steel
GS-AFF90210RW	6278130	90x210x300	Steel
GS-AFS90170RW	6277920	90x170x300	Steel
GS-AFS90210RW	6278120	90x210x300	Steel
GS-AFS70130RW	6277420	70x130x300	Steel
GS-AFS90130RW	6277520	90x130x300	Steel
GS-AFS70170RW	6277820	70x170x300	Steel
GS-AFS70210RW	6278020	70x210x300	Steel
GS-DFF70170RW	6278230	70x170x300	Steel
GS-DFF90170RW	6278330	90x170x300	Steel
GS-DFF70210RW	6278430	70x210x300	Steel

Type	Item no.	Dimensions (H x W x L)	Material
GS-DFF90210RW	6278530	90x210x300	Steel
GS-DFS70170RW	6278220	70x170x300	Steel
GS-DFS90170RW	6278320	90x170x300	Steel
GS-DFS70210RW	6278420	70x210x300	Steel
GS-DFS-90210RW	6278520	90x210x300	Steel
GS-SFS70110RW	6277020	70x110x300	Steel
GS-SFS90110RW	6277120	90x110x300	Steel
GS-SFS70130FS	6277223	70x130x300	Steel
GS-SFS70130RW	6277220	70x130x300	Steel
GS-SFS90130RW	6277320	90x130x300	Steel
GS-SFS70170RW	6277620	70x170x300	Steel
GS-SFS90170RW	6277720	90x170x300	Steel
GK-F70110RW	6274320	70x110 mm	Polyvinylchloride
GK-F70110CW	6274321	70x110 mm	Polyvinylchloride
GK-F70110LGR	6274322	70x110 mm	Polyvinylchloride
GK-F70110GR	6274326	70x110 mm	Polyvinylchloride
GK-F70130RW	6274520	70x130 mm	Polyvinylchloride
GK-F70130CW	6274521	70x130 mm	Polyvinylchloride
GK-F70130LGR	6274522	70x130 mm	Polyvinylchloride
GK-F70130GR	6274526	70x130 mm	Polyvinylchloride
GK-F70170RW	6274720	70x170 mm	Polyvinylchloride
GK-F70170CW	6274721	70x170 mm	Polyvinylchloride
GK-F70170LGR	6274722	70x170 mm	Polyvinylchloride
GK-F70170GR	6274726	70x170 mm	Polyvinylchloride
GA-SF70110RW	6279220	70x110x300	Aluminium
GA-SF70130RW	6279320	70x130x300	Aluminium
GA-SF90130RW	6276920	90x130x300	Aluminium
GA-SF70170RW	6279121	70x170x300	Aluminium
GA-AFS70170RW	6279420	70x170x300	Aluminium
GA-AFF70170RW	6279430	70x170x300	Aluminium
GA-AFS90170RW	6279520	90x170x300	Aluminium
GA-AFS90170EL	6279523	90x170x300	Aluminium
GA-AFF90170RW	6279530	90x170x300	Aluminium

Type	Item no.	Dimensions (H x W x L)	Material
GA-AFF90170EL	6279533	90x170x300	Aluminium
GA-DF90210RW	6279620	90x210x300	Aluminium
GKH-F70130RW	6114240	70x130	Polycarbonate/acrylonitrile butadiene styrene
GKH-F70170RW	6114340	70x170	Polycarbonate/acrylonitrile butadiene styrene
GEK-KF53160-3	6116493	53x160 mm	Polyvinylchloride
GK-FH70110RW	6274220	70x110 mm	Polycarbonate/acrylonitrile butadiene styrene
GK-FH70110CW	6274221	70x110 mm	Polycarbonate/acrylonitrile butadiene styrene
GK-FH70110LGR	6274222	70x110 mm	Polycarbonate/acrylonitrile butadiene styrene
GK-FH70130RW	6274420	70x130 mm	Polycarbonate/acrylonitrile butadiene styrene
GK-FH70130CW	6274421	70x130 mm	Polycarbonate/acrylonitrile butadiene styrene
GK-FH70130LGR	6274422	70x130 mm	Polycarbonate/acrylonitrile butadiene styrene
GK-FH70130SW	6274423	70x130	Polycarbonate/acrylonitrile butadiene styrene
GK-FH70170RW	6274620	70x170 mm	Polycarbonate/acrylonitrile butadiene styrene
GK-FH70170CW	6274621	70x170 mm	Polycarbonate/acrylonitrile butadiene styrene
GK-FH70170LGR	6274622	70x170 mm	Polycarbonate/acrylonitrile butadiene styrene
GK-FH70210RW	6273920	70x210 mm	Polycarbonate/acrylonitrile butadiene styrene

Tab. 5: Technical data: Flat angle

13.2.4 End piece

Type	Item no.	Dimensions (H x W x L)	Material
GA-E90130EL	6276973	90x130x37	Aluminium
GA-E70110EL	6279273	70x110x37	Aluminium
GA-E70130EL	6279373	70x130x37	Aluminium
GA-E70170EL	6279473	70x170x37	Aluminium
GA-E90210EL	6279673	90x210x37	Aluminium
GEK-SEL-133110RW	6282870	133x110 mm	Steel
GEK-SER-133110RW	6282770	133x110 mm	Steel
GS-E70110FS	6277073	70x110x10	Steel
GS-E70110RW	6277070	70x110x10	Steel
GS-E90110RW	6277170	90x110x10	Steel
GS-E70130FS	6277273	70x130x10	Steel

Type	Item no.	Dimensions (H x W x L)	Material
GS-E70130RW	6277270	70x130x10	Steel
GS-E90130RW	6277370	90x130x10	Steel
GS-E70170FS	6277673	70x170x10	Steel
GS-E70170RW	6277670	70x170x10	Steel
GS-E90170RW	6277770	90x170x10	Steel
GS-E70210RW	6278070	70x210x10	Steel
GS-E90210RW	6278170	90x210x10	Steel
GK-E70110RW	6274370	70x110 mm	Polyvinylchloride
GK-E70110CW	6274371	70x110 mm	Polyvinylchloride
GK-E70110LGR	6274372	70x110 mm	Polyvinylchloride
GK-E70110WA	6274374	70x110 mm	Polycarbonate/acrylonitrile butadiene styrene
GK-E70110GR	6274376	70x110 mm	Polyvinylchloride
GK-E70130RW	6274570	70x130 mm	Polyvinylchloride
GK-E70130SW	6274573	70x130	Polycarbonate/acrylonitrile butadiene styrene
GK-E70130CW	6274571	70x130 mm	Polyvinylchloride
GK-E70130LGR	6274572	70x130 mm	Polyvinylchloride
GK-E70130WA	6274574	70x130 mm	Polycarbonate/acrylonitrile butadiene styrene
GK-E70130GR	6274576	70x130 mm	Polyvinylchloride
GKH-E70130RW	6114280	70x130	Polycarbonate/acrylonitrile butadiene styrene
GK-E70170RW	6274770	70x170 mm	Polyvinylchloride
GK-E70170CW	6274771	70x170 mm	Polyvinylchloride
GK-E70170LGR	6274772	70x170 mm	Polyvinylchloride
GK-E70170WA	6274774	70x170 mm	Polycarbonate/acrylonitrile butadiene styrene
GK-E70170GR	6274776	70x170 mm	Polyvinylchloride
GKH-E70170RW	6114380	70x170	Polycarbonate/acrylonitrile butadiene styrene
GK-E70210RW	6274780	70x210 mm	Polyvinylchloride
GA-E70110RW	6279270	70x110x37	Aluminium
GA-E70130RW	6279370	70x130x37	Aluminium
GA-E90130RW	6276970	90x130x37	Aluminium
GA-E70170RW	6279470	70x170x37	Aluminium
GA-E90170RW	6279570	90x170x37	Aluminium
GA-E90170EL	6279573	90x170x37	Aluminium

Type	Item no.	Dimensions (H x W x L)	Material
GA-E90210RW	6279670	90x210x37	Aluminium

Tab. 6: Technical data: End piece

13.2.5 T piece

Type	Item no.	Dimensions (H x W x L)	Material
GA-AT70170EL	6279463	70x170x500	Aluminium
GA-DT90210EL	6279663	90x210x500	Aluminium
GA-ST90130EL	6276963	90x130x500	Aluminium
GA-ST70170EL	6279163	70x170x500	Aluminium
GA-ST70110EL	6279263	70x110x500	Aluminium
GA-ST70130EL	6279363	70x130x500	Aluminium
GS-AT70130RW	6277460	70x130x500	Steel
GS-AT90130RW	6277560	90x130x500	Steel
GS-AT70170RW	6277860	70x170x500	Steel
GS-AT90170RW	6277960	90x170x500	Steel
GS-AT70210RW	6278060	70x210x500	Steel
GS-AT90210RW	6278160	90x210x500	Steel
GS-DT70170RW	6278260	70x170x500	Steel
GS-DT90170RW	6278360	90x170x500	Steel
GS-DT70210RW	6278460	70x210x500	Steel
GS-DT90210RW	6278560	90x210x500	Steel
GS-ST70110RW	6277060	70x110x500	Steel
GS-ST90110RW	6277160	90x110x500	Steel
GS-ST70130RW	6277260	70x130x500	Steel
GS-ST90130RW	6277360	90x130x500	Steel
GS-ST70170RW	6277660	70x170x500	Steel
GS-ST90170RW	6277760	90x170x500	Steel
GK-TA WDK 1RW	6113310	120x62x56	Polycarbonate/acrylonitrile butadiene styrene
GK-TA WDK 1LGR	6113312	120x62x56	Polycarbonate/acrylonitrile butadiene styrene
GK-TA WDK 1AL	6113314	120x62x56	Polycarbonate/acrylonitrile butadiene styrene
GK-TA WDK 2RW	6113320	120x52x56	Polycarbonate/acrylonitrile butadiene styrene
GK-TA WDK 2LGR	6113322	120x52x56	Polycarbonate/acrylonitrile butadiene styrene

Type	Item no.	Dimensions (H x W x L)	Material
GK-TA WDK 2AL	6113324	120x52x56	Polycarbonate/acrylonitrile butadiene styrene
GK-TR53165RW	6113480	225x62x56	Polycarbonate/acrylonitrile butadiene styrene
GK-TR53165LGR	6113482	225x62x56	Polycarbonate/acrylonitrile butadiene styrene
GK-TR53165AL	6113484	225x62x56	Polycarbonate/acrylonitrile butadiene styrene
GK-T70110RW	6274360	70x110 mm	Polyvinylchloride
GK-T70110CW	6274361	70x110 mm	Polyvinylchloride
GK-T70110LGR	6274362	70x110 mm	Polyvinylchloride
GK-T70110GR	6274366	70x110 mm	Polyvinylchloride
GK-T70130RW	6274560	70x130 mm	Polyvinylchloride
GK-T70130CW	6274561	70x130 mm	Polyvinylchloride
GK-T70130LGR	6274562	70x130 mm	Polyvinylchloride
GK-T70130GR	6274566	70x130 mm	Polyvinylchloride
GK-T70170RW	6274760	70x170 mm	Polyvinylchloride
GK-T70170CW	6274761	70x170 mm	Polyvinylchloride
GK-T70170LGR	6274762	70x170 mm	Polyvinylchloride
GK-T70170GR	6274766	70x170 mm	Polyvinylchloride
GA-ST70110RW	6279260	70x110x500	Aluminium
GA-ST70130RW	6279360	70x130x500	Aluminium
GA-ST90130RW	6276960	90x130x500	Aluminium
GA-ST70170RW	6279160	70x170x500	Aluminium
GA-AT70170RW	6279460	70x170x500	Aluminium
GA-AT90170RW	6279560	90x170x500	Aluminium
GA-AT90170EL	6279563	90x170x500	Aluminium
GA-DT90210RW	6279660	90x210x500	Aluminium
GKH-T70130RW	6114270	70x130	Polycarbonate/acrylonitrile butadiene styrene
GKH-T70170RW	6114370	70x170	Polycarbonate/acrylonitrile butadiene styrene

Tab. 7: Technical data: T piece

13.3 Accessories

13.3.1 Cover

Type	Item no.	Dimensions (H x W x L)	Material
GA-OTEL	6279723	12x76.5x2,000	Aluminium
GEK-OT80	6270808	80x2,000 mm	Polyvinylchloride

Type	Item no.	Dimensions (H x W x L)	Material
GEK-OT80	6270816	80x2,000 mm	Polyvinylchloride
GS-OTFS	6279853	12x76.5x2,000	Steel
GS-OTRW	6279850	12x76.5x2,000	Steel
GS-OT50RW	6279880	12x45x2,000	Steel
AOP3S80RW	6287050	12x76.5x300	Steel
GA-OTAEI	6279727	12x76.5x300	Aluminium
GKH-OTGARW	6114230		Polycarbonate/acrylonitrile butadiene styrene
GS-OTARW	6279870	12x76.5x300	Steel
GS-OT50ARW	6279890	12x45x300	Steel
IOP3RW	6287080	12x76.5x300	Steel
FOOP3RW	6287060	12x76.5x400	Steel
FUOP3RW	6287070	12x76.5x400	Steel
GKH-OTGFRW	6114250		Polycarbonate/acrylonitrile butadiene styrene
GS-OTFFS	6279863	12x76.5x400	Steel
GS-OTFRW	6279860	12x76.5x400	Steel
GS-OT50FRW	6279990	12x45x400	Steel
GA-OTRW	6279720	12x76.5x2,000	Aluminium
GA-OTARW	6279725	12x76.5x300	Aluminium
GA-OTFRW	6279734	12x76.5x400	Aluminium
GA-OTFEL	6279736	12x76.5x400	Aluminium
GK-OTGRW	6278680	80x2,000 mm	Polyvinylchloride
GK-OTGCW	6278681	80x2,000 mm	Polyvinylchloride
GK-OTGLGR	6278682	80x2,000 mm	Polyvinylchloride
GK-OTGSW	6278684	2,000x80	Polyvinylchloride
GK-OTGGR	6278686	80x2,000 mm	Polyvinylchloride
GK-OTKRW	6278780	80x2,000 mm	Polyvinylchloride
GK-OTGO	6278690	80x2,000 mm	Polycarbonate
GKH-OTGRW	6114210	70x2,000	Polycarbonate/acrylonitrile butadiene styrene
GK-OTKKPI	6278790	80x2,000 mm	Polycarbonate
GK-OTGARW	6274790		Polyvinylchloride
GK-OTGACW	6274791		Polyvinylchloride
GK-OTGALGR	6274792		Polyvinylchloride
GK-OTGAGR	6274796		Polyvinylchloride

Type	Item no.	Dimensions (H x W x L)	Material
GK-OTKARW	6274890		Polyvinylchloride
GK-OTGFRW	6274490		Polyvinylchloride
GK-OTGFCW	6274491		Polyvinylchloride
GK-OTGFLGR	6274492		Polyvinylchloride
GK-OTGFGR	6274496		Polyvinylchloride
GK-OTKFRW	6274590		Polyvinylchloride
GA-OTRW 100	6279715	12x76.5x100	Aluminium
GA-OTEL 100	6279733	12x76.5x100	Aluminium
GS-OTRW 100	6286930	12x76.5x100	Steel

Tab. 8: Technical data: Cover

13.3.2 Joint cover

Type	Item no.	Dimensions (H x W x L)	Material
G-SVS70110RW	6279760	70x110x30 mm	Steel
G-SVS70130RW	6279764	70x130x30 mm	Steel
G-SVS70170RW	6279768	70x170x30 mm	Steel
G-SVS70210RW	6279772	70x210x30 mm	Steel
G-SVS90110RW	6279776	90x110x30 mm	Steel
G-SVS90130RW	6279780	90x130x30 mm	Steel
G-SVS90170RW	6279784	90x170x30 mm	Steel
G-SVS90210RW	6279788	90x210x30 mm	Steel

Tab. 9: Technical data: Joint cover

13.3.3 Partition

Type	Item no.	Dimensions (H x W x L)	Material
GA-TW70	6279711	8.4x51x2,000	Steel
GA-TW90	6279714	8.4x70x2,000	Steel
GK-TW53	6113290	38x13x2,000	Polyvinylchloride
GS-TW70	6277090	24x53x2,000	Steel
GS-TW90	6277095	24x73x2,000	Steel
TWP	6288264	14x92x2,000	Steel
GK-TW70	6274900	70x2,000 mm	Polyvinylchloride
GKH-TW70	6114290	70x2,000	Polycarbonate/acrylonitrile butadiene styrene

Tab. 10: Technical data: Partition

13.3.4 Accessory mounting boxes

Type	Item no.	Dimensions (H x W x L)	Material
71GD7-2	6288608	51x76x142	Polyamide
71GD8-2	6288569	51x76x71	Polyamide
71GD13	6288583	51x76x140	Polyamide
71GD9-2	6288579	51x76x160	Polyamide
71GD11	6288532	51x76x71	Polyamide
71GDCEE	6288635	73x84x117	Polyamide
71GDBS1	6288585	35x76x77	Polyamide
71GDBS2	6288586	35x76x137	Polyamide
7ZE	6288790	28x34x14	Polyamide
Z70C	6249997	42x70x1.4 mm	Steel
7GD5	6288590	60x80x139	Polyamide
71GD10	6288554	50x76x87	Polyamide
71GD6	6288610	51x76x71	Polyamide
71GD6 100	6288609	51x76x71	Polyamide
71VD80	6279817	55x50x78	Polypropylene

Tab. 11: Technical data: Accessory mounting boxes

13.3.5 Wall end piece

Type	Item no.	Dimensions (H x W x L)	Material
G-AWAG70130RW	6278850	138x198x25	Aluminium
G-AWAG70170RW	6278860	138x238x25	Aluminium
G-AWAG70210RW	6278870	138x278x25	Aluminium
G-AWAG90110RW	6279020	158x178x25	Aluminium
G-AWAG90130RW	6279030	158x198x25	Aluminium
G-AWAG90170RW	6279040	158x238x25	Aluminium
G-AWAG90210RW	6279050	158x278x25	Aluminium
G-AWAO70130RW	6278810	104x198x25	Aluminium
G-AWAO70170RW	6278820	104x238x25	Aluminium
G-AWAO70210RW	6278830	104x278x25	Aluminium
G-AWAO90110RW	6278880	124x178x25	Aluminium
G-AWAO90130RW	6278890	124x198x25	Aluminium
G-AWAO90170RW	6279000	124x238x25	Aluminium
G-AWAO90210RW	6279010	124x278x25	Aluminium

Type	Item no.	Dimensions (H x W x L)	Material
G-KWAG70170RW	6274870	138x238x25	Acrylonitrile butadiene styrene
G-KWAG70210RW	6274880	138x278x25	Acrylonitrile butadiene styrene
G-KWAO70110RW	6274810	104x178x25	Acrylonitrile butadiene styrene
G-KWAO70130RW	6274820	104x198x25	Acrylonitrile butadiene styrene
G-KWAO70170RW	6274830	104x238x25	Acrylonitrile butadiene styrene
G-KWAO70210RW	6274840	104x278x25	Acrylonitrile butadiene styrene
G-KWAO90110RW	6274910	124x178x25	Acrylonitrile butadiene styrene
G-KWAO90130RW	6274920	124x198x25	Acrylonitrile butadiene styrene
G-KWAO90170RW	6274930	124x238x25	Acrylonitrile butadiene styrene
G-KWAO90210RW	6274940	124x278x25	Acrylonitrile butadiene styrene
G-AWAO70110RW	6278800	104x178x25	Aluminium
G-AWAG70110RW	6278840	138x178x25	Aluminium

Tab. 12: Technical data: Wall end piece

13.3.6 Mounting support for accessory mounting boxes

Type	Item no.	Dimensions (H x W x L)	Material
71MT1 45	6288572	15x76x71	Polyamide
71MT2 45	6288576	15x76x127	Polyamide
71MT3 45-2	6288574	15x76x160	Polyamide
71MTD	6288577	14x76x71	Polyamide

Tab. 13: Technical data: Mounting support for accessory mounting boxes

13.3.7 Cover frame

Type	Item no.	Dimensions (H x W x L)	Material
AR45-BF1 RW	6119332	84x84 mm	Polycarbonate
AR45-BF1 SWGR	6119334	84x84 mm	Polycarbonate
AR45-BF1 AL	6119336	84x84 mm	Polycarbonate
AR45-BSF1 RW	6119338	84x84 mm	Polycarbonate
AR45-BSF1 SWGR	6119339	84x84 mm	Polycarbonate
AR45-BSF1 AL	6119340	84x84 mm	Polycarbonate
AR45-F2 RW	6119342	84x140 mm	Polycarbonate
AR45-F2 SWGR	6119344	84x140 mm	Polycarbonate

Type	Item no.	Dimensions (H x W x L)	Material
AR45-F2 AL	6119346	84x140 mm	Polycarbonate
AR45-BF2 RW	6119352	84x140 mm	Polycarbonate
AR45-BF2 SWGR	6119354	84x140 mm	Polycarbonate
AR45-BF2 AL	6119356	84x140 mm	Polycarbonate
AR45-BSF2 RW	6119362	84x140 mm	Polycarbonate
AR45-BSF2 SWGR	6119364	84x140 mm	Polycarbonate
AR45-BSF2 AL	6119366	84x140 mm	Polycarbonate
AR45-F3 RW	6119372	84x185 mm	Polycarbonate
AR45-F3 SWGR	6119374	84x185 mm	Polycarbonate
AR45-F3 AL	6119376	84x185 mm	Polycarbonate
AR45-BF3 RW	6119382	84x185 mm	Polycarbonate
AR45-BF3 SWGR	6119384	84x185 mm	Polycarbonate
AR45-BF3 AL	6119386	84x185 mm	Polycarbonate
AR45-BSF3 RW	6119387	84x185 mm	Polycarbonate
AR45-BSF3 SWGR	6119388	84x185 mm	Polycarbonate
AR45-BSF3 AL	6119389	84x185 mm	Polycarbonate
AR45-F1 RW	6119322	84x84 mm	Polycarbonate
AR45-F1 SWGR	6119324	84x84 mm	Polycarbonate
AR45-F1 AL	6119326	84x84 mm	Polycarbonate
AR50-F1 RW	6119392	84x84 mm	Polycarbonate
AR50-F1 SWGR	6119394	84x84 mm	Polycarbonate
AR50-F1 AL	6119396	84x84 mm	Polycarbonate

Tab. 14: Technical data: Cover frame

13.3.8 Saw cores

Type	Item no.	Dimensions (H x W x L)	Material
SK GS-A70130	6288736	67x127x160	Steel
SK GS-A90130	6288737	87x127x160	Steel
SK GS-A70170	6288740	67x167x220	Steel
SK GS-A90170	6288741	87x167x220	Steel
SK GS-A70210	6288744	67x207x230	Steel
SK GS-A90210	6288745	87x207x230	Steel
SK GS-D70170	6288742	67x167x160	Steel
SK GS-D90170	6288743	87x167x160	Steel

Type	Item no.	Dimensions (H x W x L)	Material
SK GS-D70210	6288746	67x207x160	Steel
SK GS-D90210	6288747	87x207x160	Steel
SK GEK-SA133110	6288749	130x107x160	Steel
SK GS-S70110	6288732	67x107x160	Steel
SK GS-S90110	6288733	87x107x160	Steel
SK GS-S70130	6288734	67x127x160	Steel
SK GS-S90130	6288735	87x127x160	Steel
SK GS-S70170	6288738	67x167x220	Steel
SK GS-S90170	6288739	87x167x220	Steel

Tab. 15: Technical data: Saw cores

13.3.9 Additional accessory parts

Type	Item no.	Dimensions (H x W x L)	Material
KL80A	6288640	94x25x12	Polycarbonate/acrylonitrile butadiene styrene
RKV3V	6288700	11x20x6	Steel
GA-KUP70	6279701	64x120	Stainless steel, rustproof 1.4301
GA-KUP90	6279704	84x120	Stainless steel, rustproof 1.4301
GS-KUP70	6277290	70x120	Stainless steel, rustproof 1.4301
GS-KUP90	6277294	90x120	Stainless steel, rustproof 1.4301
KUPP	6288680	133x105	Stainless steel, rustproof 1.4301
BKN50 80	6288001	140x128x83	Steel
BKN200 350	6288007	140x128x351	Steel
8AWR	6288704	20x12x15	Steel
SDE-RW D0RW2	6119407	84x140x59 mm	Polycarbonate
GK-KUP	6274650	64x90 mm	Acrylonitrile butadiene styrene
8VS4	6287810	4x40	Steel
7LSB	6288650	30x300 mm	Mineral fibres
7LSB M	6288651	30x50,000 mm	Mineral fibres
WZ3RW	6288720	Approx. 10 ml	
2390/Z8	6270727		Polyvinylchloride

Tab. 16: Technical data: Additional accessory parts

OBO Bettermann Holding GmbH & Co. KG
P.O. Box 1120
58694 Menden
GERMANY

Technical Office
Tel.: +49 (0)2373 89-1300

technical-office@obo.de

www.obo-bettermann.com

Date 10/2025

241090.05

Building Connections

