

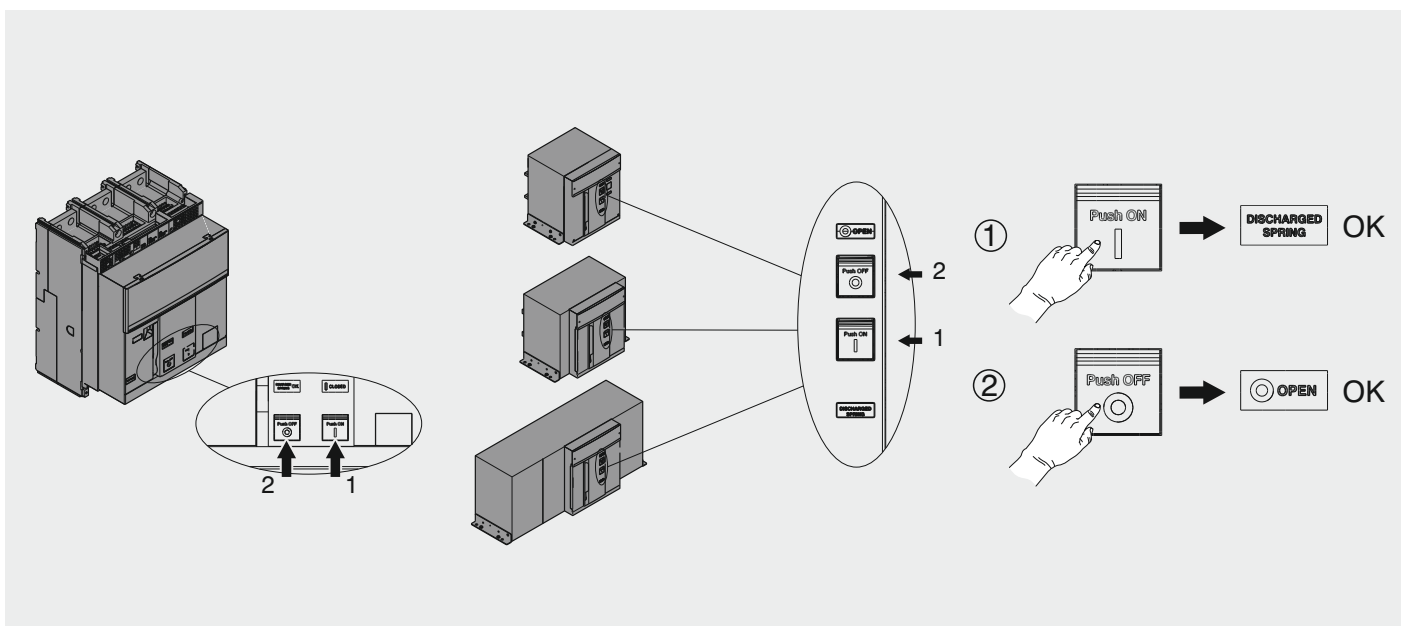

SACE Emax 2

Interblocco meccanico MI tipo A - E1.2 con E2.2-E4.2-E6.2
Mechanical interlock MI type A - E1.2 with E2.2-E4.2-E6.2
Mechanische Verriegelung MI typ A - E1.2 bei E2.2-E4.2-E6.2
Verrouillage mécanique MI type A - E1.2 avec E2.2-E4.2-E6.2
Enclavamiento mecánico MI tipo A - E1.2 con E2.2-E4.2-E6.2

E1.2-E2.2-E4.2-E6.2





ATTENZIONE! Dove è indicato il simbolo  la lubrificazione deve essere effettuata con grasso tipo mobilgrease 28, disponibile anche nel greasing kit ABB (1SDA076082R1).











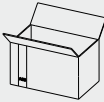

WARNING! Lubricate where indicated by the  symbol using grease of the mobilgrease 28 type, also available in the ABB greasing kit (1SDA076082R1).









ACHTUNG! Wo das Symbol  angegeben ist, muss die Schmierung mit Fett der Sorte Mobilgrease 28 ausgeführt werden, das auch im ABB Greasing Kit verfügbar ist (1SDA076082R1).



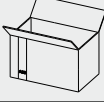
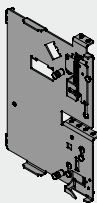







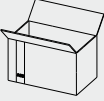
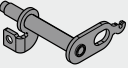

ATTENTION! Là où est indiqué le symbole  la lubrification doit être effectuée avec de la graisse type mobilgrease 28, disponible aussi dans le Kit greasing d'ABB (1SDA076082R1).

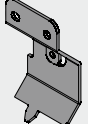









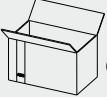



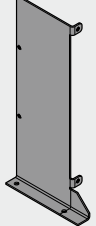







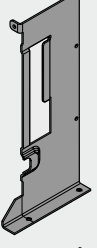





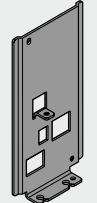



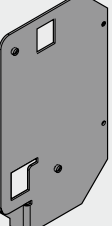

¡ATENCIÓN! Donde está indicado el símbolo  la lubricación se deberá efectuar con grasa tipo mobilgrease 28, disponible también en el greasing kit ABB (1SDA076082R1).

1x 	Group 1	F - W
1A		2
1B		2
1C	 M4x10	2
1D		8
1E		8
1F	 Ø _{int} 6	4
1G	 M4	2
1H	 M6	4
1Ia	 M5	2
1Ib	 M5	2
1L		2

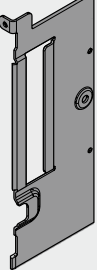
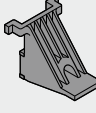
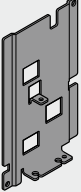
E2.2-E4.2-E6.2

1x 	Group 3 / Group 4	F - W	F ONLY	W ONLY
3A		1		
3B			1	
3C			2	
3D	 M6x40		2	
3E	 M6x10		1	
3F	 Ø _{int} 6 Ø _{ext} 13.1	2	1	
3G	 M6x12			2

1x 	Group 2	F - W	F ONLY	W ONLY
2A		1		
2B		1		
2C		1		
2D		1		
2E		1		
2F				1
2G			1	
2H		1		
2L	 M5x20	1		
2M	 M4x7	2		
2N	 M4x10	1		
2P	 M4	1		
2Q	 Ø _{int} 4	2		

1x  Group 3 / Group 4	Estraibile Withdrawable Ausfahrbar débrochable Extraible	Montaggio a parete wall mounting Wandanbau montage sur paroi montaje en la pared	Montaggio a pavimento floor mounting Fußbodenanbau montage sur sol montaje en el suelo	Montaggio a parete wall mounting Wandanbau montage sur paroi montaje en la pared	Montaggio a pavimento floor mounting Fußbodenanbau montage sur sol montaje en el suelo
4A   M4x12		2	2		
4B   M4x10		2	6	4S 	1
4C   M4x30		2	2		
4D   M5x25			4		
4E   M4		2	4		1
4E1   M4		2	4	4S1 	
4F   M5			4		
4G   Ø_{int} 5			4		
4H   Ø_{int} 4		2	2	4T 	1
4I 		2	2		
4J 		1	1		
4K 	2	2	2	4U 	1
4L   M5x8	2				
4M   M4x16	1				
4N   Ø_{int} 4	1			4V 	1
4O 	1				
4P 	1			4W 	1
4Q 	1			4X 	1
4R 	1			4Y 	1
				4Z 	1

1**E1.2 - F ONLY**

Foratura piano di appoggio per passaggio cavi
 Mounting surface drilling for cable
 Bohrung Auflagefläche für Kabel
 Perçage plan d'appui pour le câble
 Taladrado de la superficie de apoyo para el cable

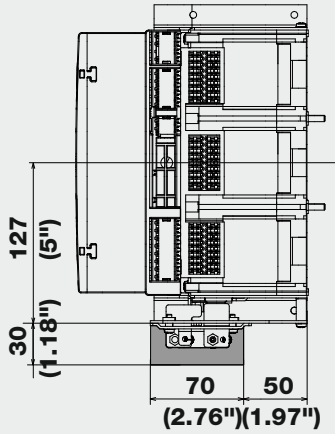
**2****E1.2 - W ONLY**

Foratura piano di appoggio per passaggio cavi
 Mounting surface drilling for cable
 Bohrung Auflagefläche für Kabel
 Perçage plan d'appui pour le câble
 Taladrado de la superficie de apoyo para el cable

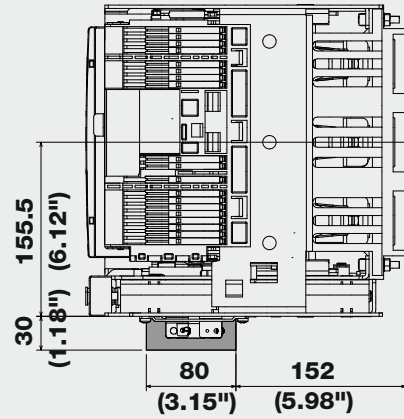
**3****E2.2-E4.2-E6.2 - F ONLY**

Foratura piano di appoggio per passaggio cavi
 Mounting surface drilling for cable
 Bohrung Auflagefläche für Kabel
 Perçage plan d'appui pour le câble
 Taladrado de la superficie de apoyo para el cable

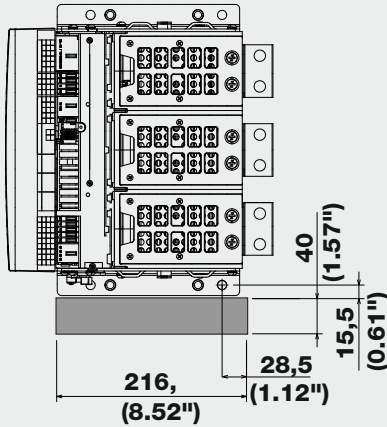
**4****E2.2-E4.2-E6.2 - W ONLY**

Foratura piano di appoggio per passaggio cavi
 Mounting surface drilling for cable
 Bohrung Auflagefläche für Kabel
 Perçage plan d'appui pour le câble
 Taladrado de la superficie de apoyo para el cable

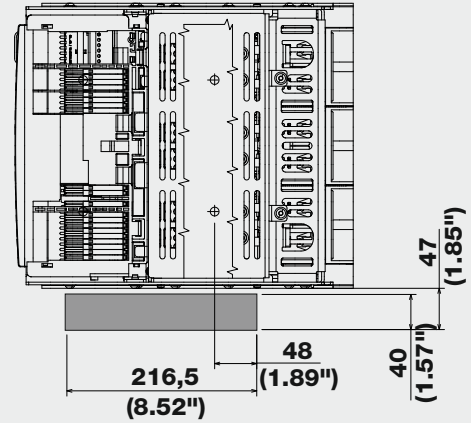
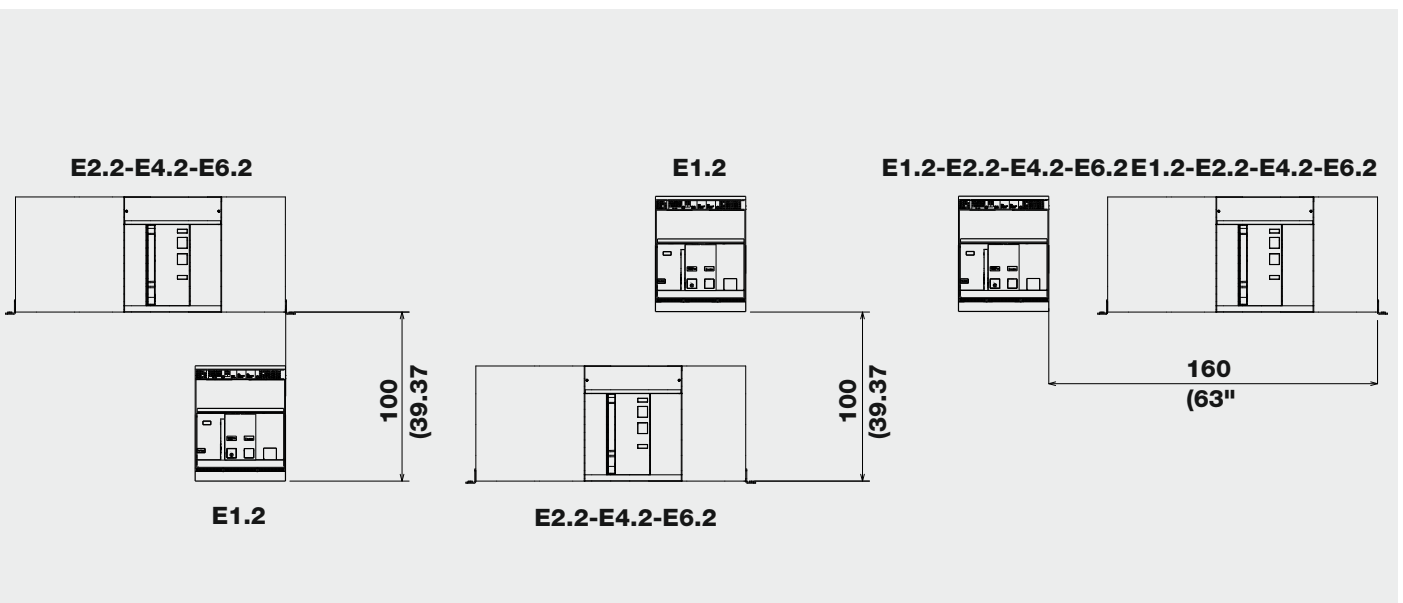
**5**

6

E1.2 - W

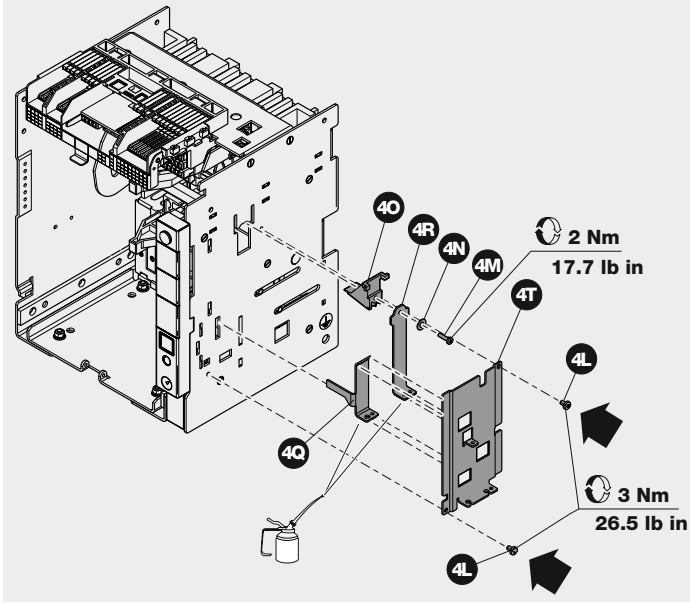

7

E1.2 - W

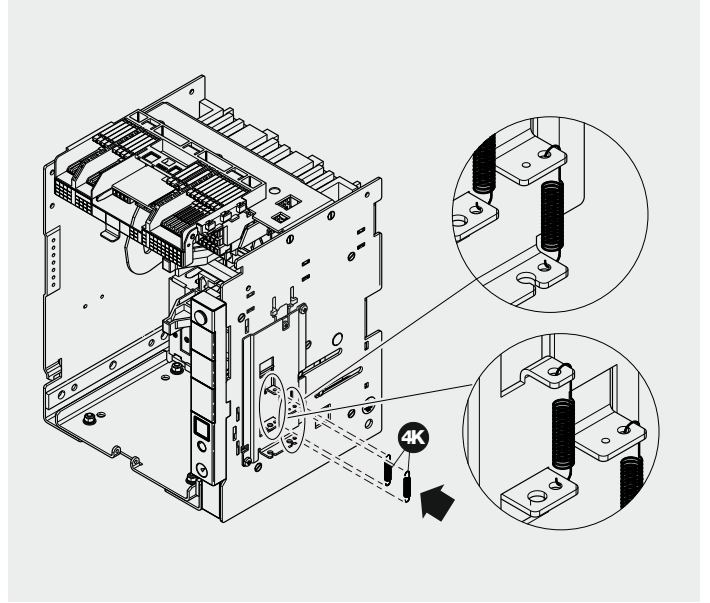

8

E1.2 - F

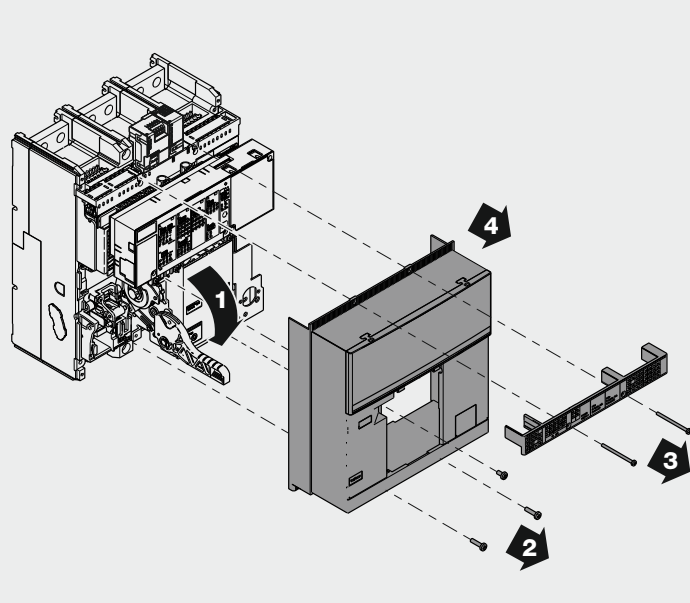

9

WALL MOUNTED E1.2 F

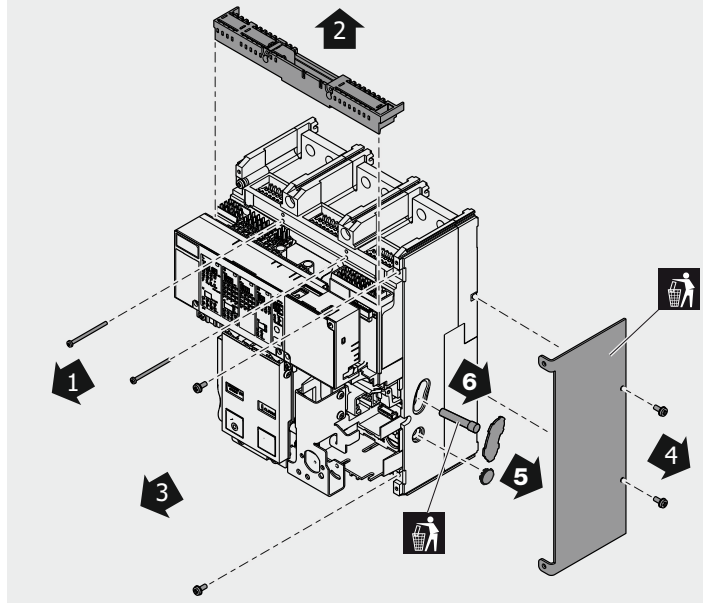

10

WALL MOUNTED E1.2 F

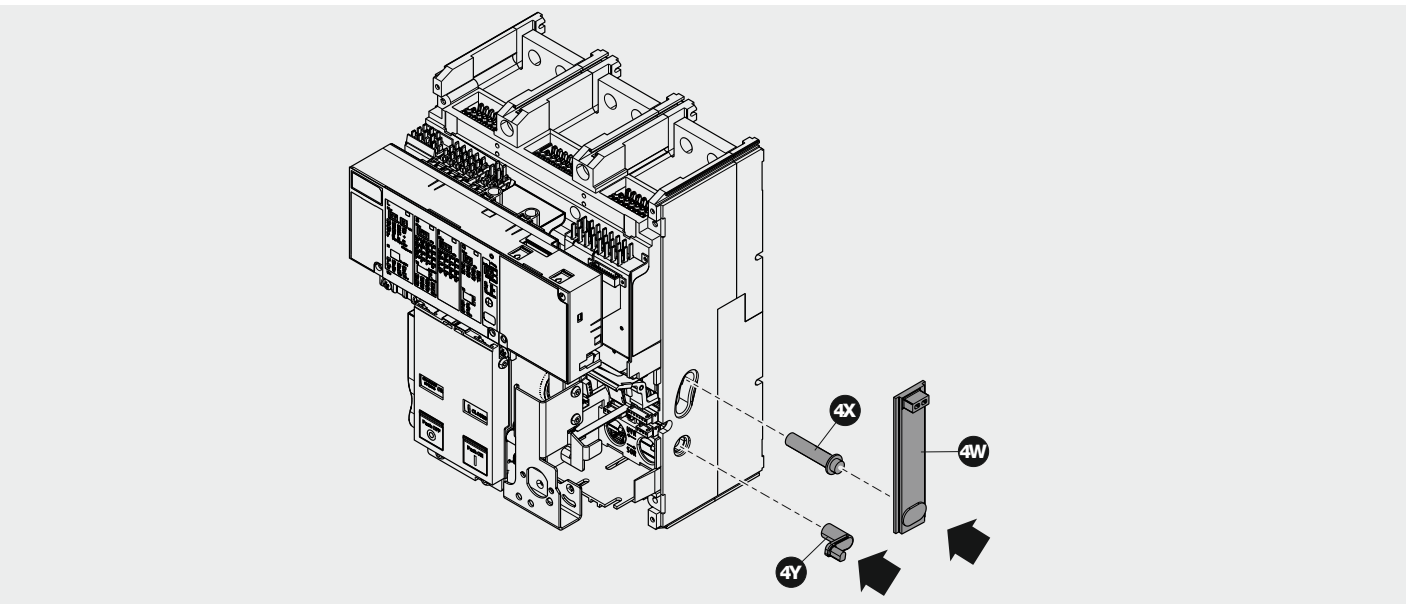

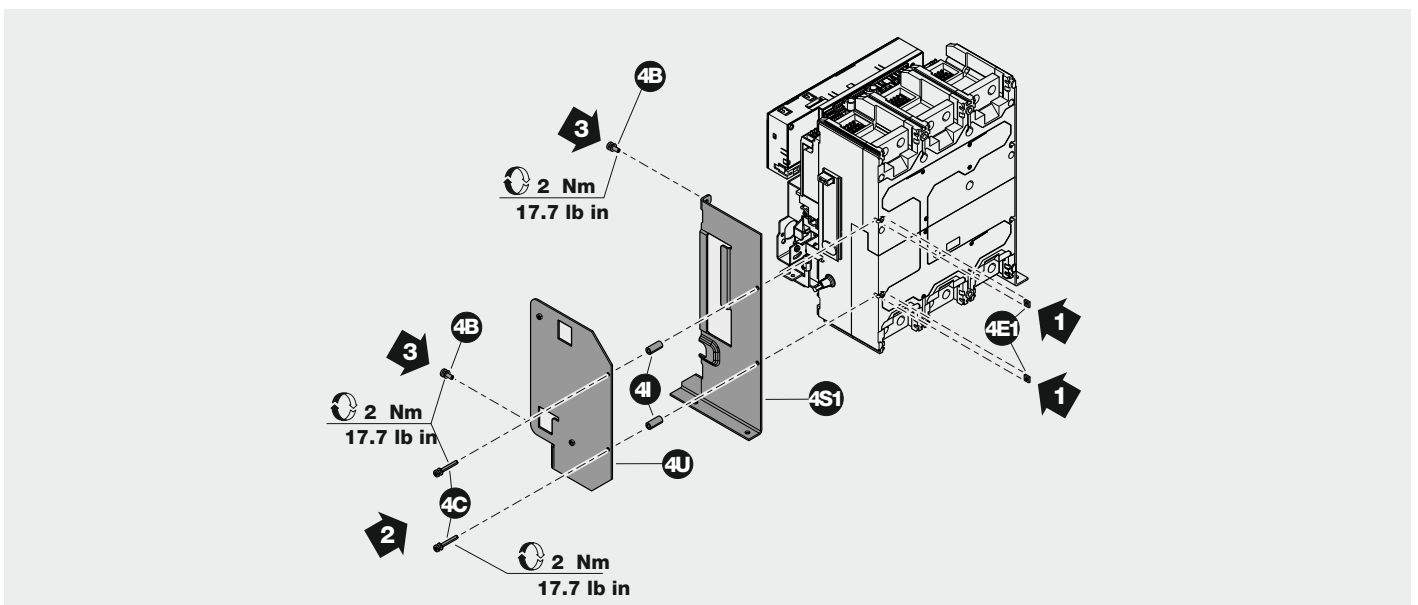
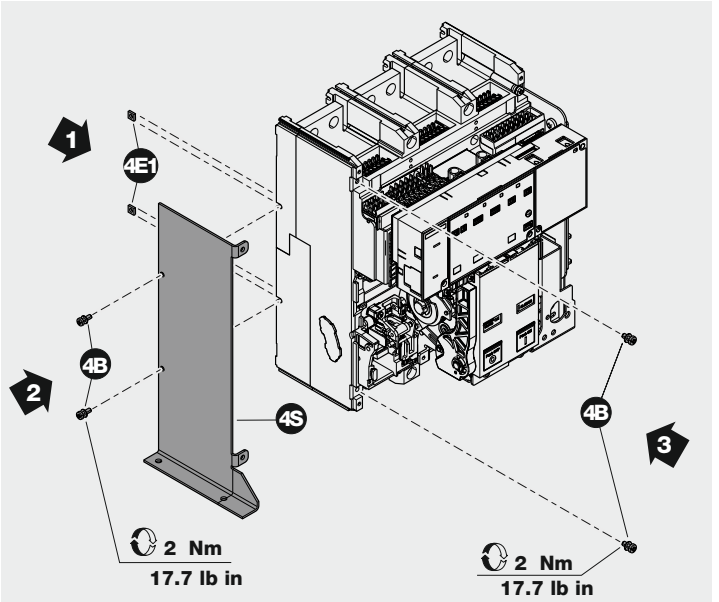
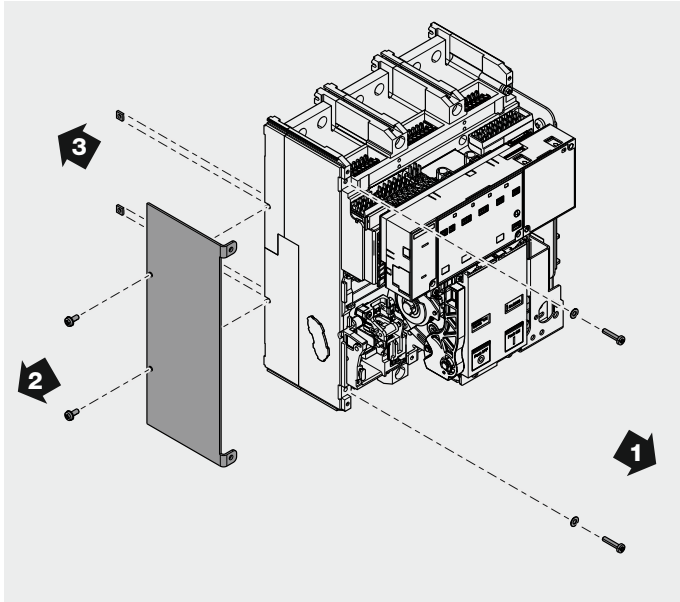
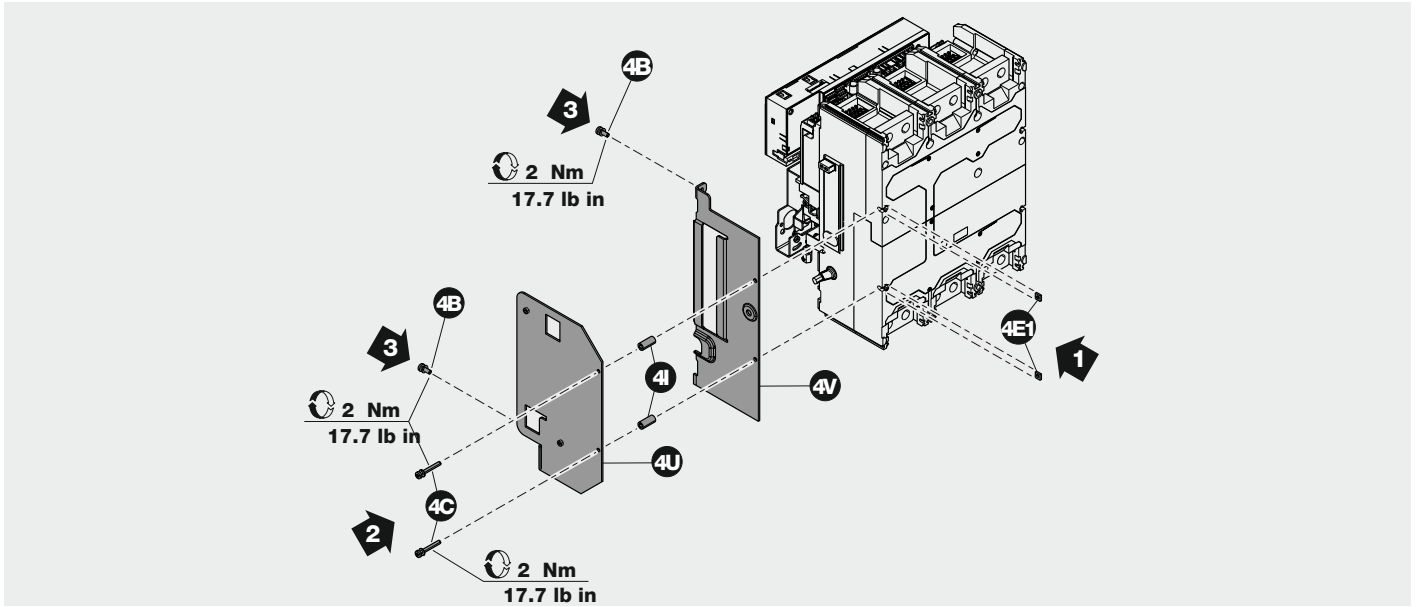

15

FOR ALL E1.2 F

Esempio per montaggio a parete
Example for wall mounting
Beispiel für Wandanbau
Exemple pour montage sur paroi
Ejemplo para montaje en la pared

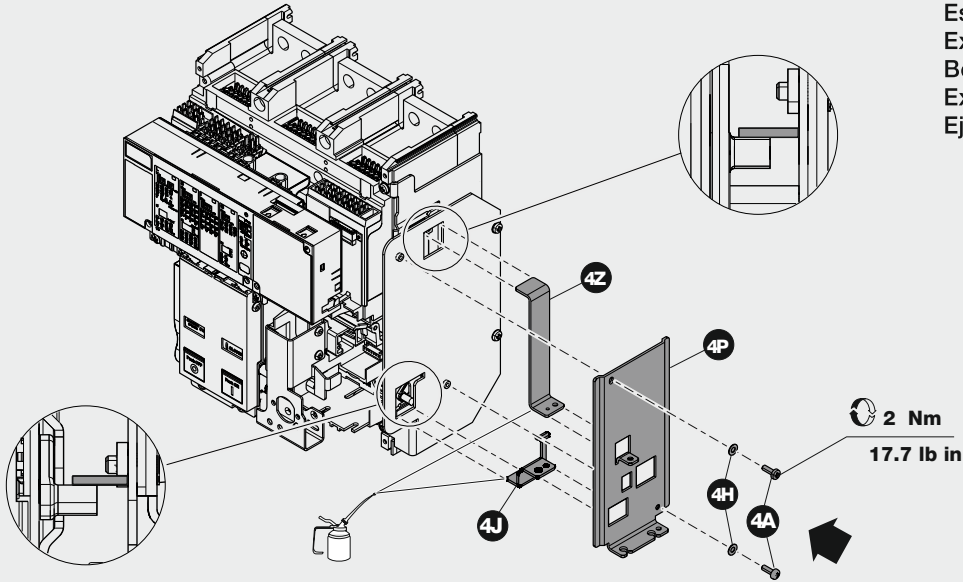

16

FOR ALL E1.2 F

Esempio per montaggio a parete
Example for wall mounting
Beispiel für Wandanbau
Exemple pour montage sur paroi
Ejemplo para montaje en la pared

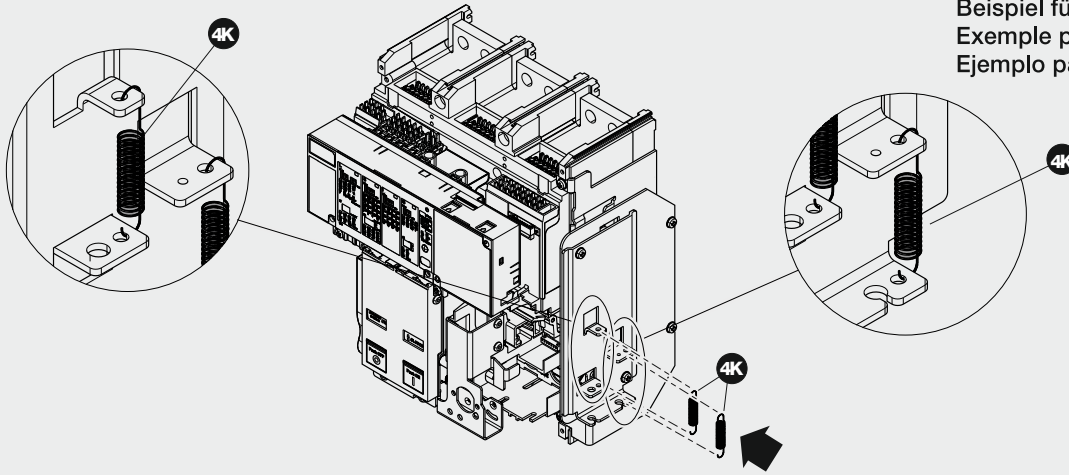

17

FOR ALL E1.2 (W-F)

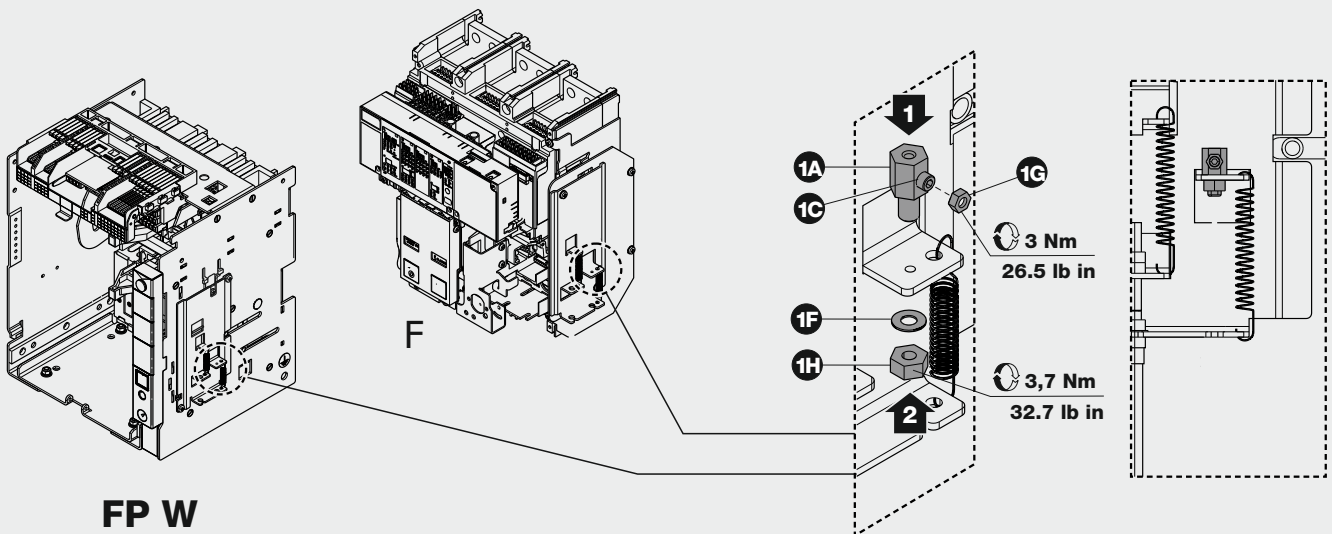

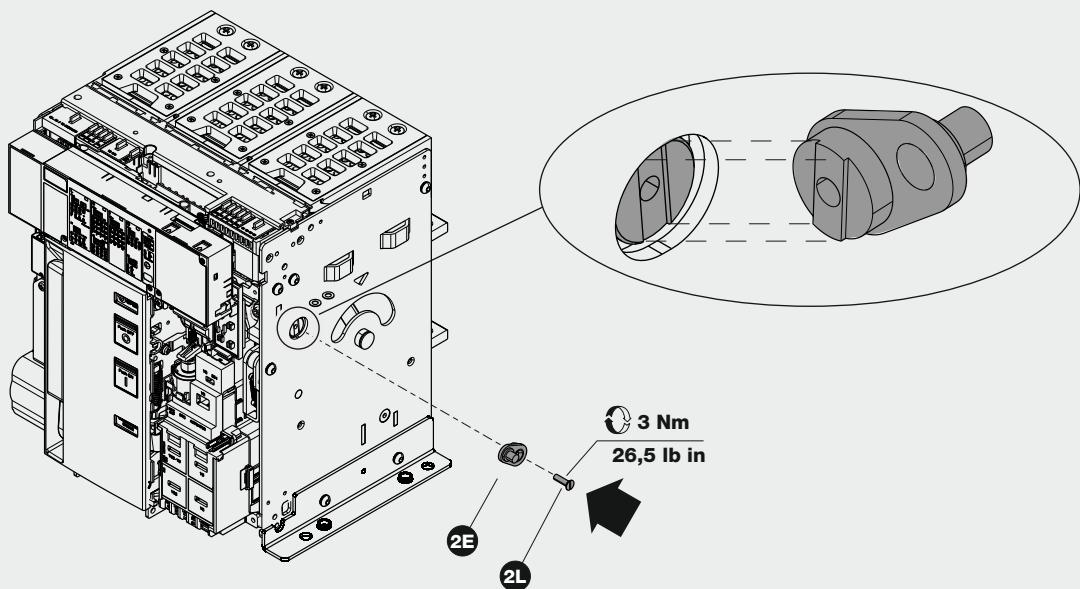
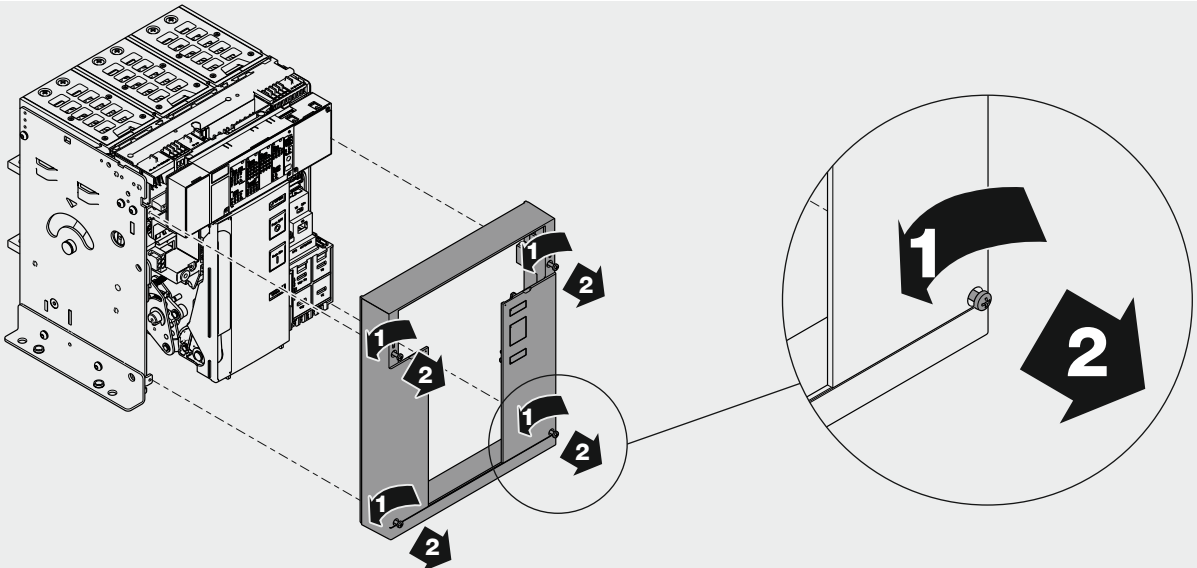
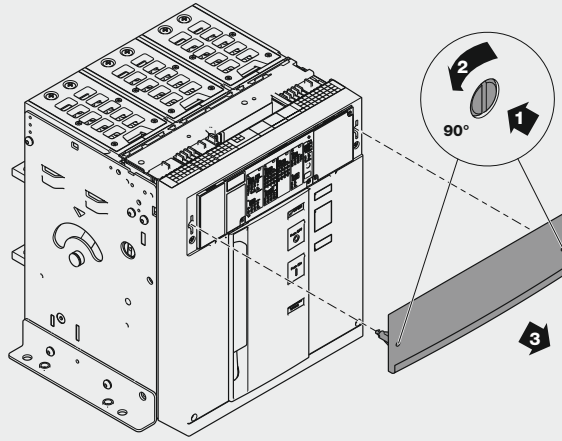

Verificare il libero scorrimento delle parti in movimento.
Make sure the moving parts slide freely.
Ungehinderte Bewegung der Bewegungsteile überprüfen.
Vérifier que les parties en mouvement coulissent librement.
Compruebe que las partes movibles se deslicen libremente.

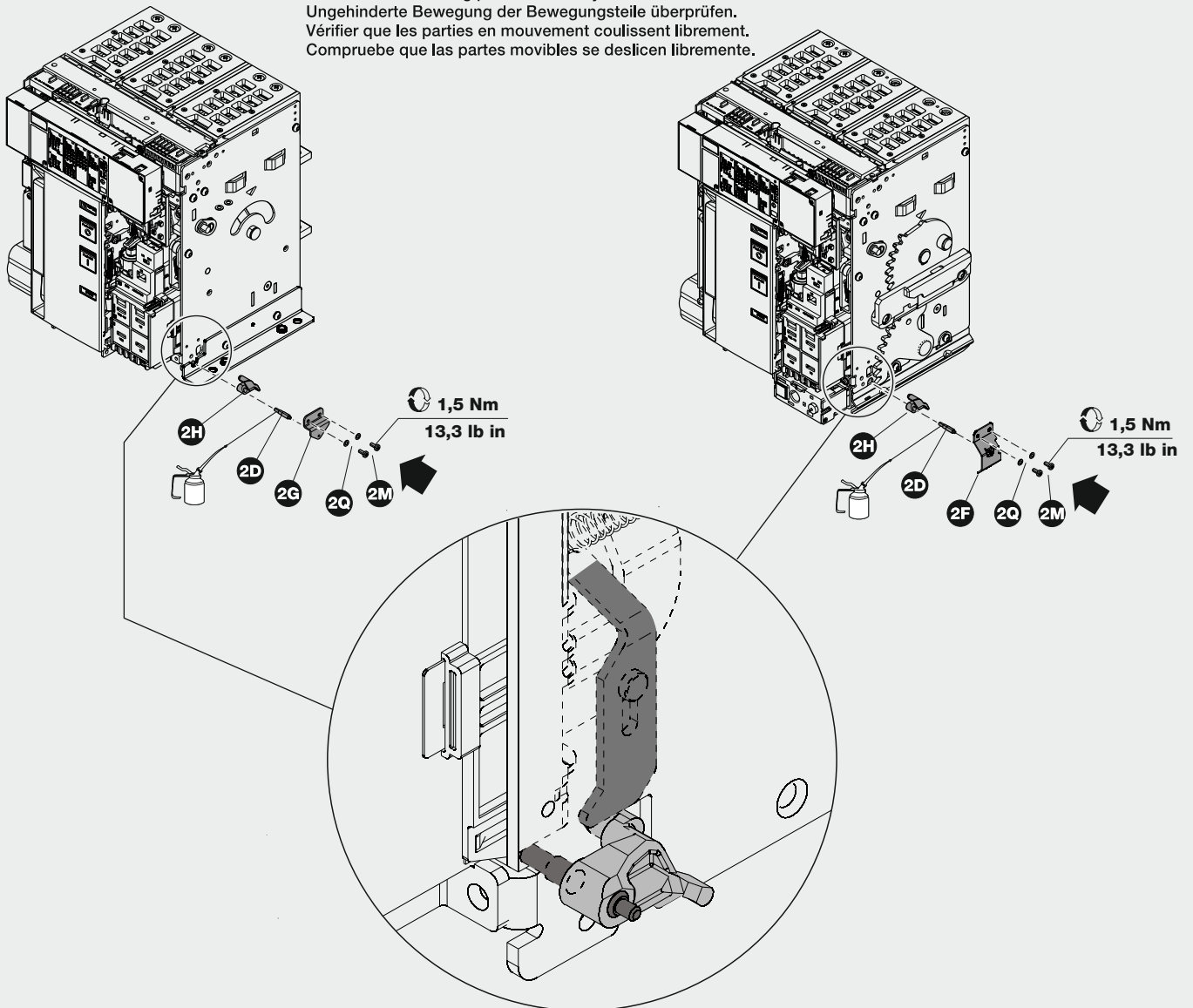

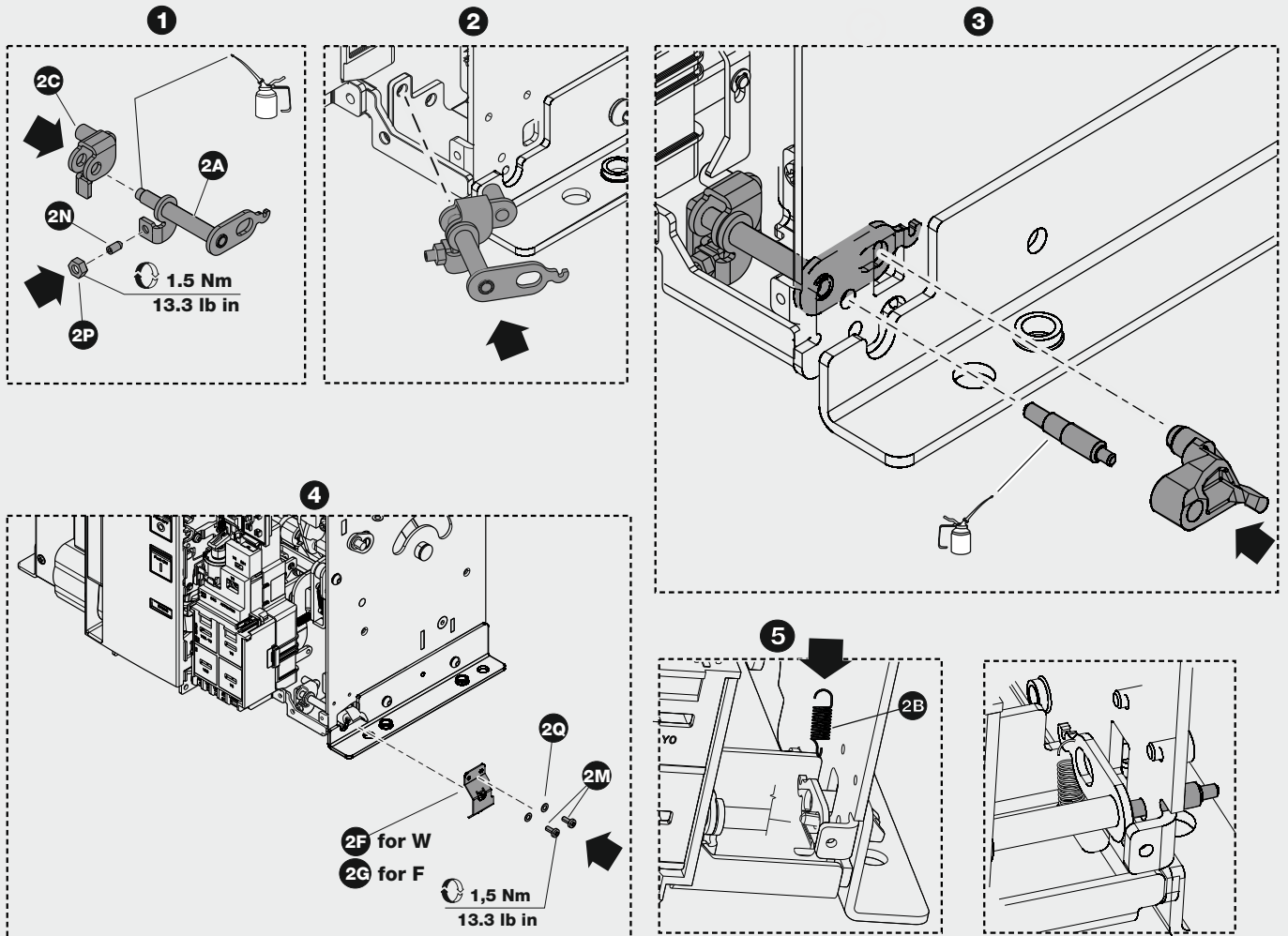

Tenere premuta verso il basso l'asta "X1", avvitare il grano "X2" fino ad eliminare il gioco tra perno "X4" ed asta e stringere il controdamo "X3". Se questa operazione è già stata effettuata da ABB, accertarsi dell'assenza di gioco tra l'asta "X1" ed il perno "X4". Se necessario, ripetere la regolazione come indicato. Verificare il libero scorrimento delle parti in movimento.

Keep rod "X1" pressed down, screw in grub screw "X2" until clearance between pin "X4" and rod is eliminated, and tighten lock nut "X3". If this operation has already been performed by ABB, make sure that there is no backlash between rod "X1" and pin "X4". If necessary, repeat the adjustments as indicated. Make sure all moving parts slide freely.

Die Stange "X1" nach unten gedrückt halten, die Madenschraube "X2" anziehen, bis das Spiel zwischen dem Bolzen "X4" und der Stange aufgehoben ist, und die Gegenmutter "X3" anziehen.

Wenn dieser Vorgang schon von ABB vorgenommen worden ist, sicherstellen, dass zwischen der Stange "X1" und dem Bolzen „X4“ kein Spiel vorhanden ist. Bei Bedarf ist die Einstellung wie angegeben zu wiederholen. Ungehinderte Bewegung der Bewegungsteile überprüfen.

Maintenir la tige "X1" appuyée vers le bas, visser la vis sans tête "X2" jusqu'à éliminer le jeu entre l'axe "X4" et la tige puis serrer le contre-écrou "X3". Si cette opération a déjà été effectuée par ABB, vérifier l'absence de jeu entre la tige "X1" et l'axe "X4". Si nécessaire répéter le réglage comme indiqué. Vérifier que les parties en mouvement coulisent librement.

Mantener apretado hacia abajo el vástago "X1", enroscar el pasador "X2" hasta eliminar el juego entre el perno "X4" y el vástago y apretar la contratuerca "X3". Si ABB ya ha efectuado esta operación, cerciorarse de la ausencia de juego entre la varilla "X1" y el perno "X4". Si es necesario repetir el ajuste como se ha indicado. Compruebe que las partes móviles se deslicen libremente.

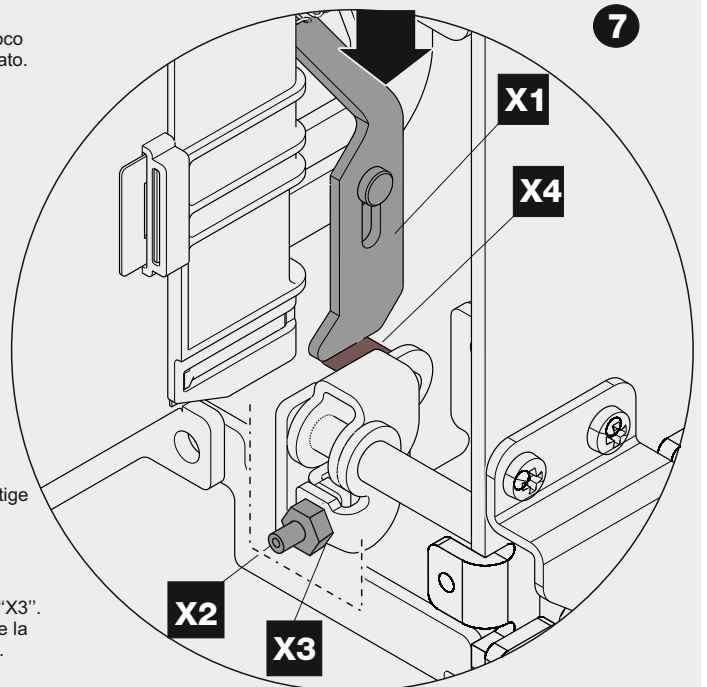

Ripetere in senso inverso le operazioni di figure 18 e 19.
Repeat the operations shown in figures 18 and 19 in reverse order.
Die Vorgänge der Abbildungen 18 und 19 in der umgekehrten Richtung wiederholen.
Répéter les opérations des figures 18 et 19 dans le sens inverse.
Repetir las operaciones de las figuras 18 y 19 en sentido contrario.

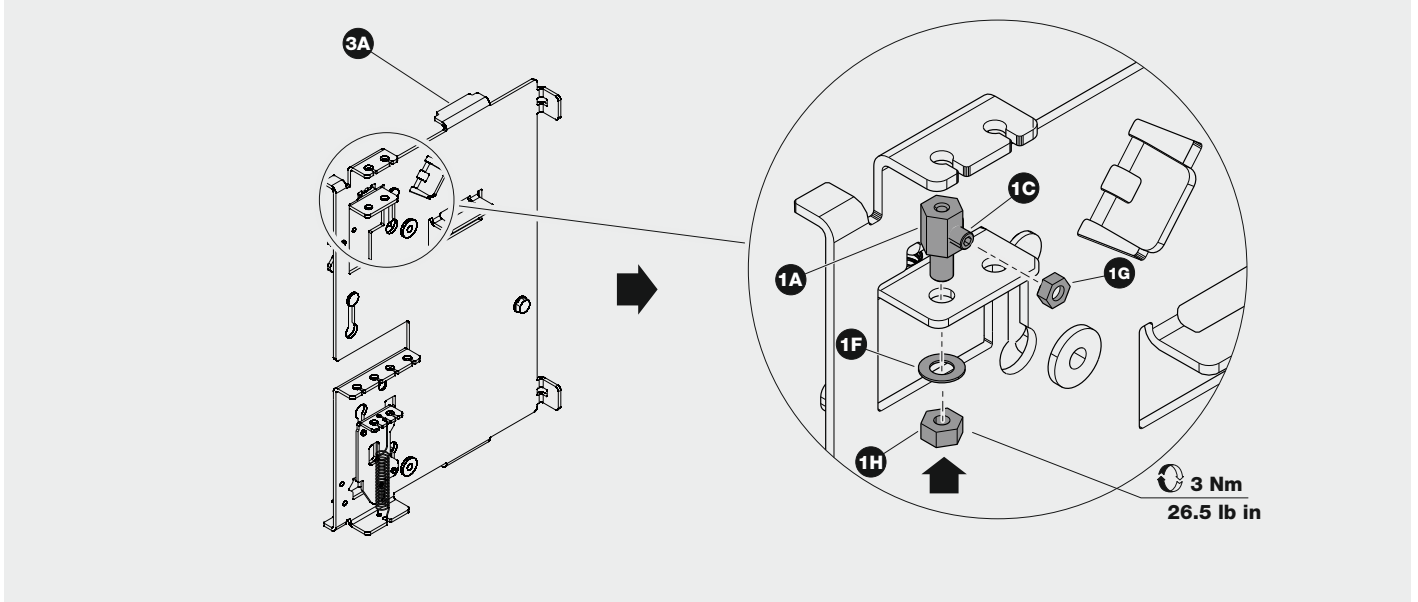

25

W ONLY

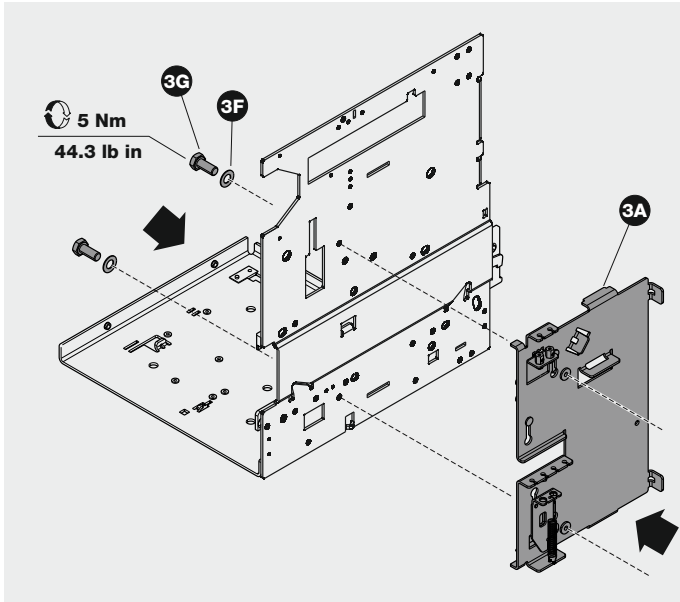

26

W ONLY

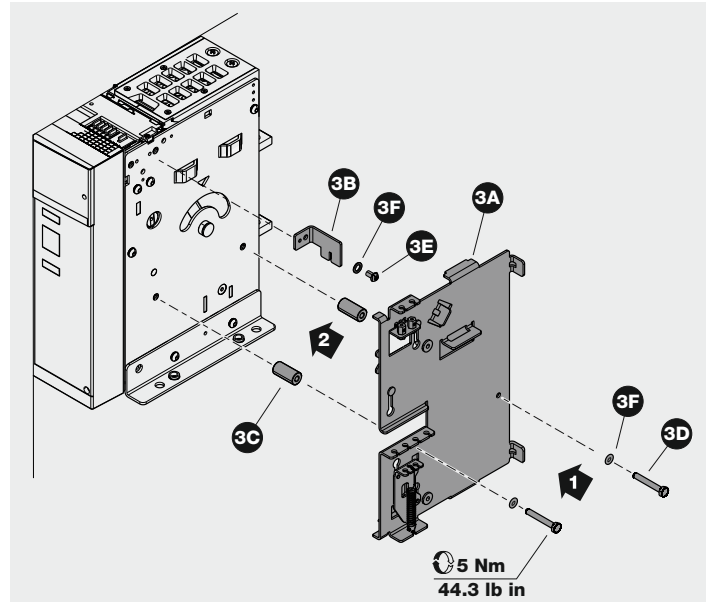

27

F ONLY

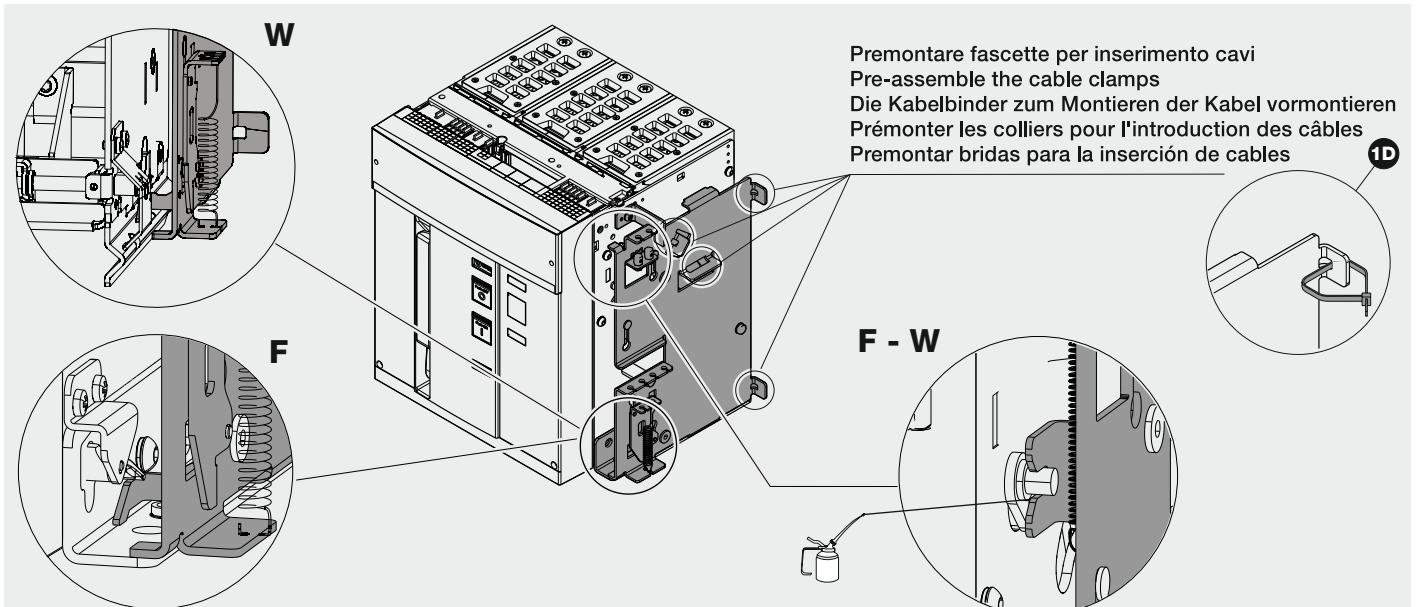

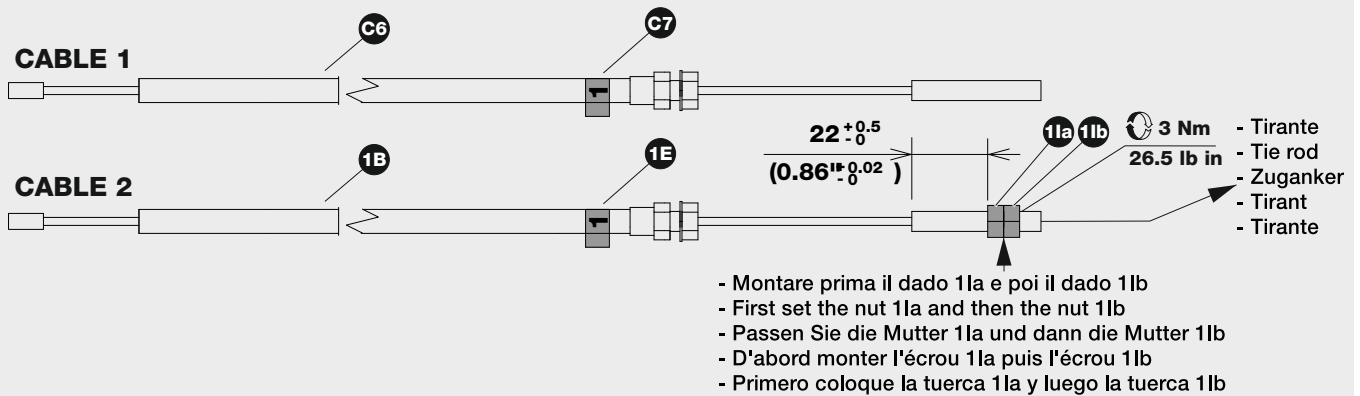

29

VERTICAL / HORIZONTAL INSTALLATION

- Inserire i cavi nelle fascette come da schema sottostante.
- Nel fissare i cavi flessibili agli interruttori ridurre al minimo il numero delle curve (somma curve max 360°); Le curve devono avere raggio min 70mm (min 2.76").
- Insert cables into the cable ties as shown in the diagram below.
- When attaching flexible cables to circuit-breakers, reduce the number of curves as much as possible (maximum sum of curves 360°); The curves must have radius min 70mm (min 2.76").
- Die Kabel in die Kabelbinder einstecken, wie es im folgenden Schaltplan zu sehen ist.
- Bei der Befestigung der flexiblen Kabel an den Schaltgeräten die Anzahl von Kurven auf ein Minimum beschränken (Summer der Kurven max. 360°); Kurven müssen minimalen Radius 70mm (min 2.76").
- Passer les câbles dans les colliers comme dans le schéma ci-dessous.
- Lorsqu'on fixe les câbles flexibles sur les disjoncteurs, réduire au minimum le nombre de coudes (somme des coudes 360° maxi); Courbes doivent avoir un rayon 70mm minimum (min 2.76").
- Introducir los cables en las bridas como se ve en el diagrama aquí abajo
- Al fijar los cables flexibles a los interruptores, reducir al mínimo el número de codos (suma de codos máx. 360°); Las curvas deben tener 70 mm de radio mínimo (min 2.76")

30

VERTICAL INSTALLATION

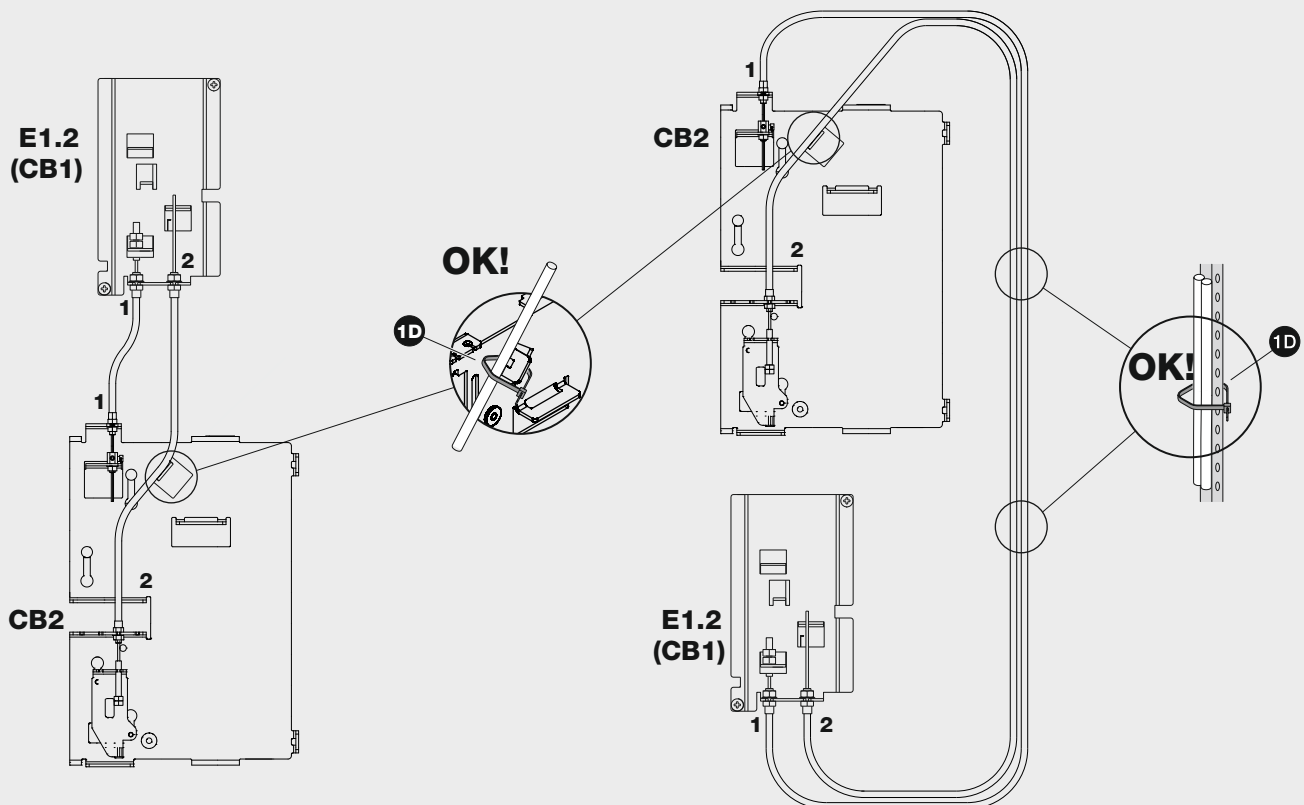

- Posizionare i cavi sotto CB/parti fisse collegandoli al quadro mediante le fascette.
- Route cables below CB/fixed parts and fasten them to switchgear with cable ties.
- Die Kabel unten dem Leistungsschalter/den Festteilen positionieren und sie mittels Kabelbindern an der Schaltanlage anschließen.
- Positionner les câbles au dessous de le Disjoncteur/parties fixes en le branchant au tableau à l'aide de colliers.
- Posicionar los cables abajo interruptor/partes fijas conectándolos al cuadro mediante las bridas.

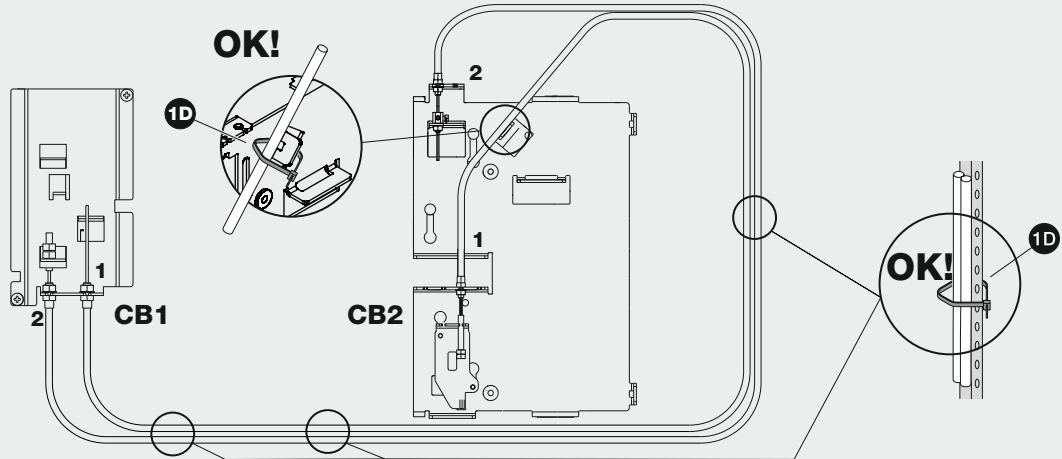

32

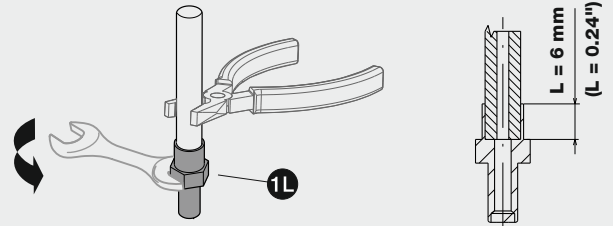
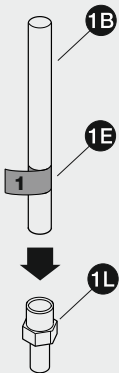

Tenere ferma con una pinza la guaina e avvitare con una chiave inglese Ch8 il dado alla quota indicata
 Hold the sheath with a pair of pliers and tighten the nut with an adjustable wrench Ch8 to the indicated position
 Mit einer Zange die Hülle festhalten und mit einem englischen Schlüssel Ch8 die Mutter mit dem angegebenen Wert anziehen
 Tenir la gaine avec une pince et visser à l'aide d'une clé anglaise Ch8 l'écrou à la cote indiquée
 Mantener fija con una pinza la vaina y enroscar con una llave inglesa Ch8 la tuerca a la cota indicada

33

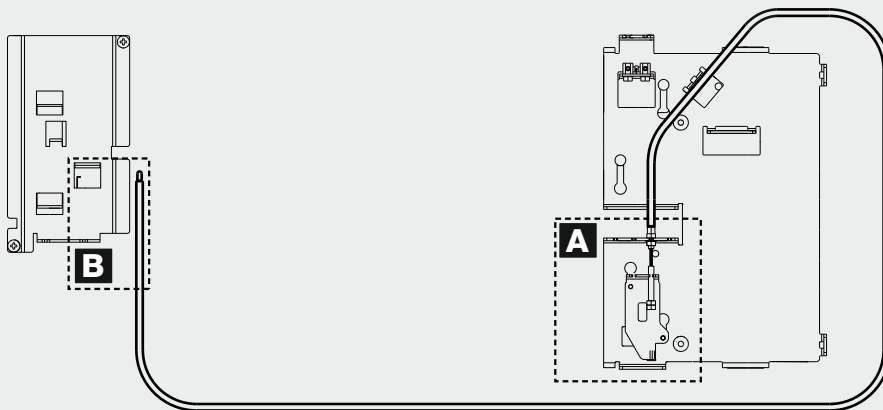

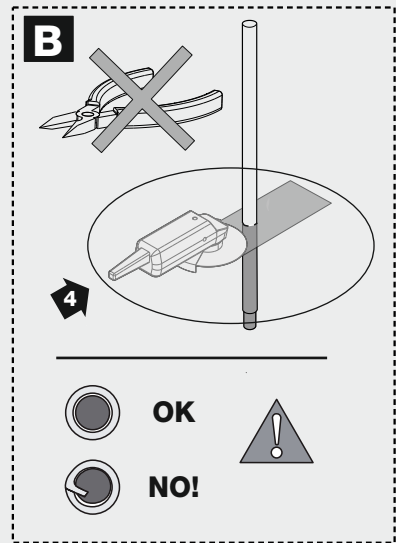
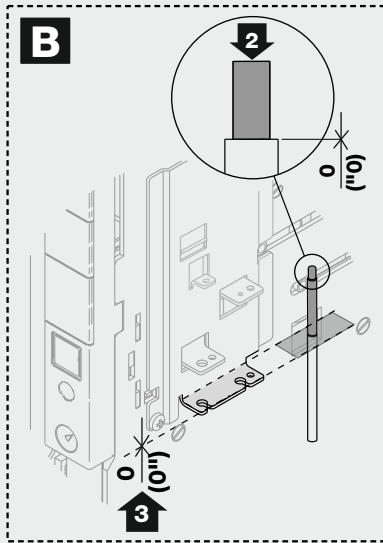
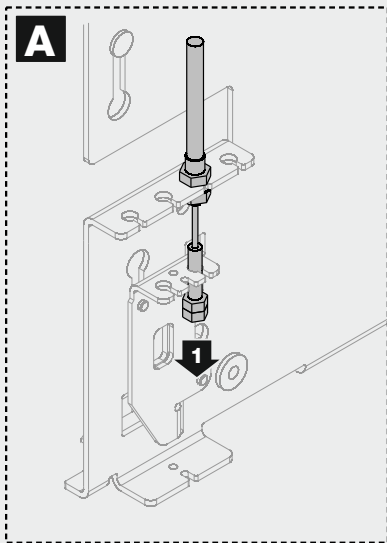
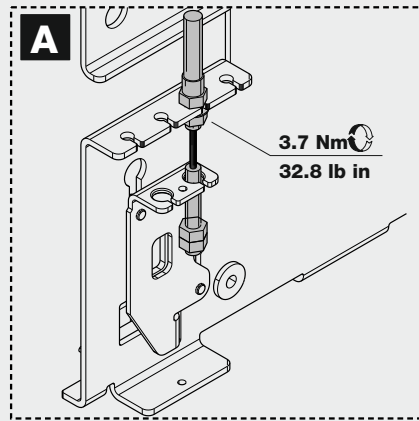
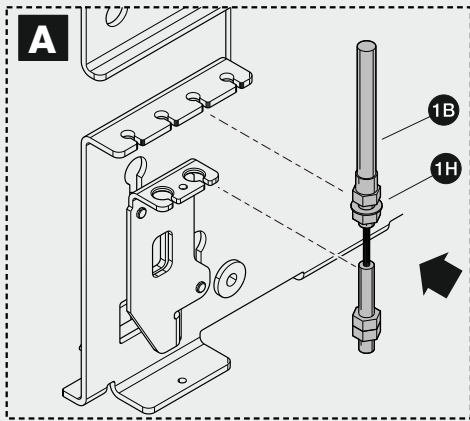

- Tirare il cavo nella guaina come indicato dalla freccia 1 (A) fino a che il puntale dalla parte opposta (B) va in battuta sulla guaina come indicato dalla freccia 2 e segnare il cavo per il taglio, in corrispondenza del piano indicato dalla freccia 3 e tagliare come mostrato dalla freccia 4.
- Pull cable into sheath as shown by arrow 1 until tip from opposite side comes up against the sheath as shown by arrow 2. Mark cable for cutting on a level with the plane indicated by arrow 3, then cut as shown by arrow 4.
- Das Kabel wie von Pfeil 1 angegeben in der Hülle ziehen, bis die Spitze von der Gegenseite her zum Anschlag auf der Hülle gelangt, wie es von Pfeil 2 angegeben wird, und das Kabel auf der Höhe der Ebene, die von Pfeil 3 angezeigt wird, zum Schneiden vorbereiten und wie von Pfeil 4 gezeigt durchschneiden.
- Tirer le câble dans la gaine comme indiqué par la flèche 1 jusqu'à ce que l'embout de la partie opposée aille en butée comme indiqué par la flèche 2 et marquer le câble pour la coupe, au niveau du plan indiqué par la flèche 3 et couper comme montré par la flèche 4.
- Tirar del cable en la funda como indica la flecha 1 hasta que la punta de la parte opuesta toque con la funda como indica la flecha 2; marcar el cable para el corte, en correspondencia con el plano indicado por la flecha 3; cortar como muestra la flecha 4.

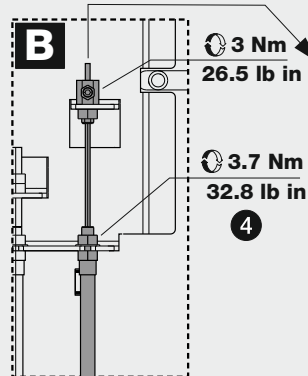
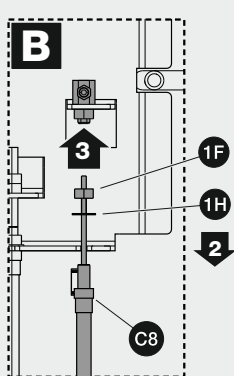
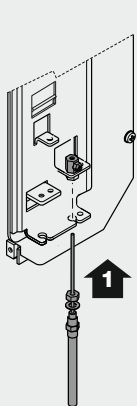

È consigliato applicare un capocorda all'estremità del cavo (capocorda a cura del cliente).

It is advisable to apply a cable terminal to the end of the cable (cable terminal at customer's charge).

Es empfiehlt sich, am Ende des Kabels einen Kabelschuh anzubringen (Kabelschuh als bauseitige Leistung).

Il est conseillé d'appliquer une cosse à l'extrémité du câble (cosse à la charge du client).

Es aconsejable aplicar un terminal en el extremo del cable (terminal a cargo del cliente).

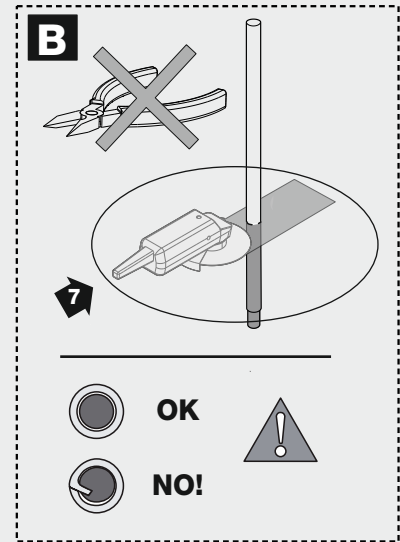
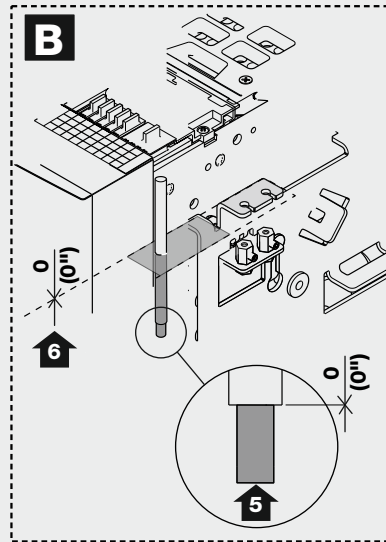
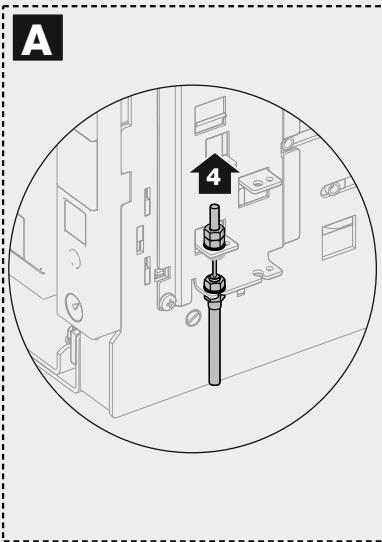
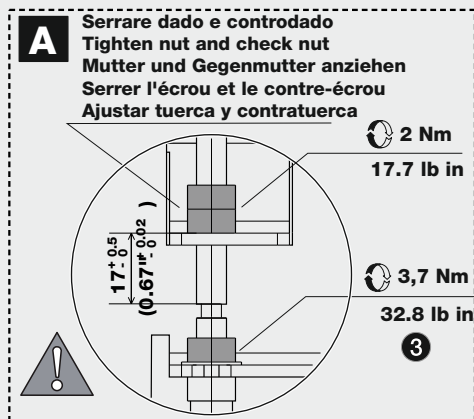
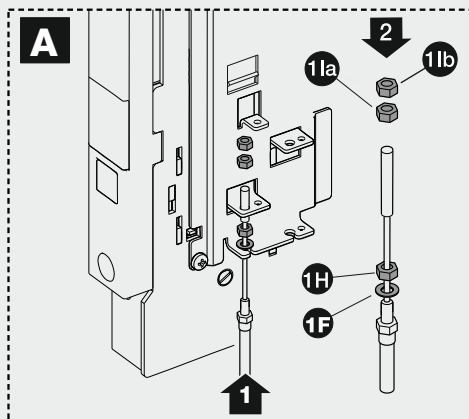
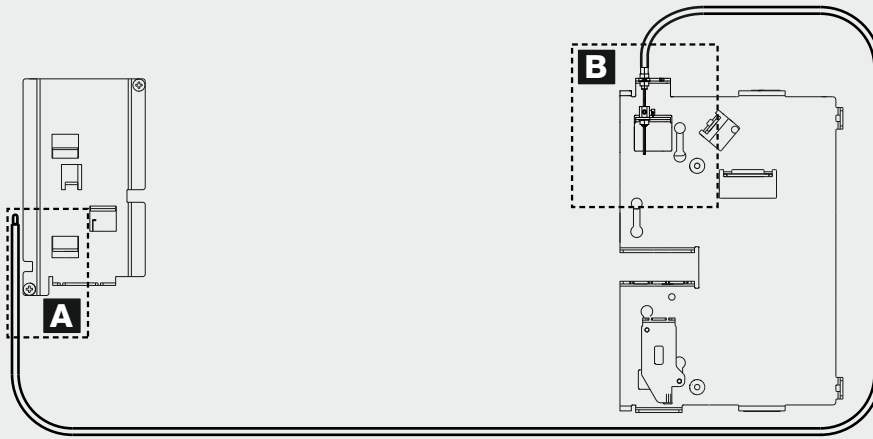

- Tirare il cavo nella guaina come indicato dalla freccia 4 (A) fino a che il puntale dalla parte opposta (B) va in battuta sulla guaina come indicato dalla freccia 5 e segnare il cavo per il taglio, in corrispondenza del piano indicato dalla freccia 6 e tagliare come mostrato dalla freccia 7.
- Pull cable into sheath as shown by arrow 4 until tip from opposite side comes up against the sheath as shown by arrow 5. Mark cable for cutting on a level with the plane indicated by arrow 6, then cut as shown by arrow 7.
- Das Kabel wie von Pfeil 4 angegeben in der Hülle ziehen, bis die Spitze von der Gegenseite her zum Anschlag auf der Hülle gelangt, wie es von Pfeil 5 angegeben wird, und das Kabel auf der Höhe der Ebene, die von Pfeil 6 angezeigt wird, zum Schneiden vorbereiten und wie von Pfeil 7 gezeigt durchschneiden.
- Tirer le câble dans la gaine comme indiqué par la flèche 4 jusqu'à ce que l'embout de la partie opposée aille en butée comme indiqué par la flèche 5 et marquer le câble pour la coupe, au niveau du plan indiqué par la flèche 6 et couper comme montré par la flèche 7.
- Tirar del cable en la funda como indica la flecha 4 hasta que la punta de la parte opuesta toque con la funda como indica la flecha 5; marcar el cable para el corte, en correspondencia con el plano indicado por la flecha 6; cortar como muestra la flecha 7.

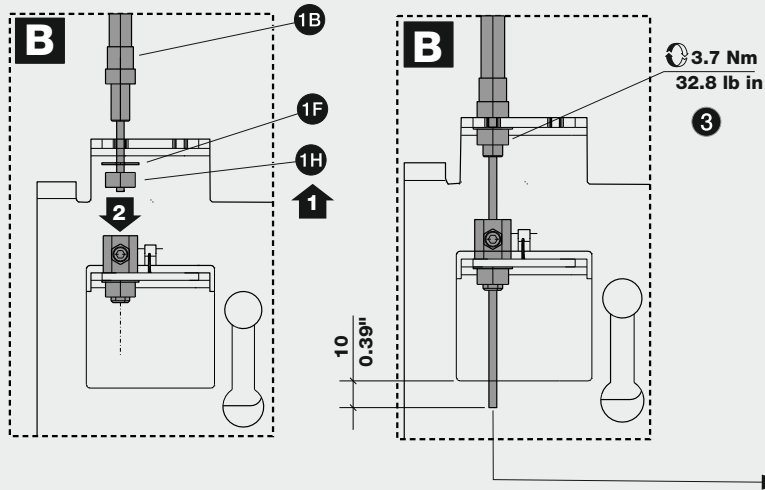

È consigliato applicare un capocorda all'estremità del cavo (capocorda a cura del cliente).

It is advisable to apply a cable terminal to the end of the cable (cable terminal at customer's charge).

Es empfiehlt sich, am Ende des Kabels einen Kabelschuh anzubringen (Kabelschuh als bauseitige Leistung).

Il est conseillé d'appliquer une cosse à l'extrémité du câble (cosse à la charge du client).

Es aconsejable aplicar un terminal en el extremo del cable (terminal a cargo del cliente).

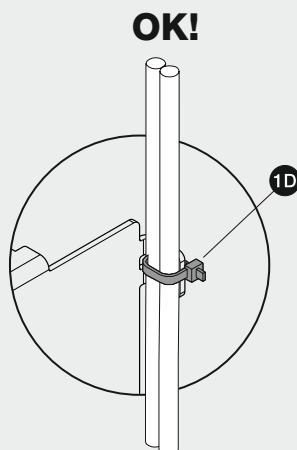

ATTENZIONE: Stringere le fascette per assicurarsi che la forma dei cavi non possa essere modificata dopo la regolazione.

WARNING: Tighten the bands to make sure that the shape of the cables can not be changed after adjusting.

ACHTUNG: Ziehen Sie die Schellen fest, um sicherzustellen, dass die Form der Kabel nach der Einstellung nicht verändert werden kann.

ATTENTION: Serrez les collier de serrage pour vous assurer que la forme des câbles ne peut pas être changée après le réglage.

ATENCIÓN: Apriete los abrazaderas para asegurarse de que la forma de los cables no se puede cambiar después de la regulación.

E1.2

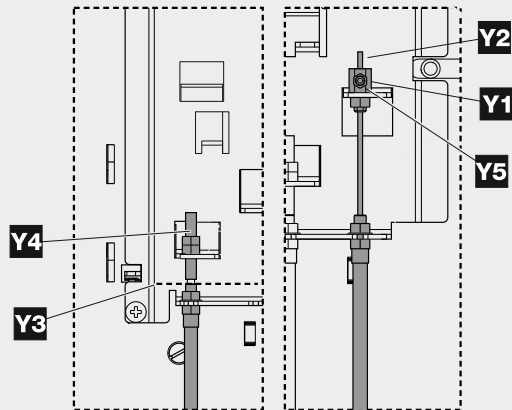

E2.2-E4.2-E6.2

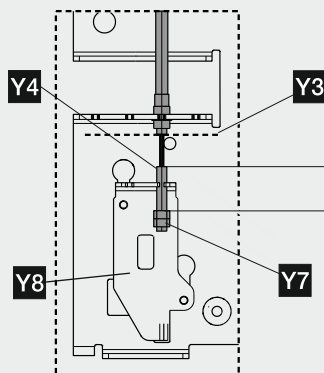
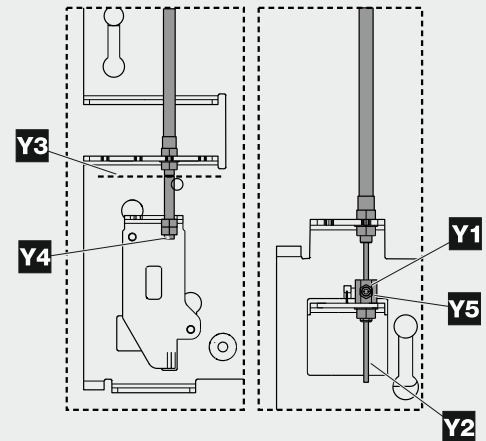

22 (min. 21 - max. 22.5)
0.86" (min. 0.83" - max. 0.89)

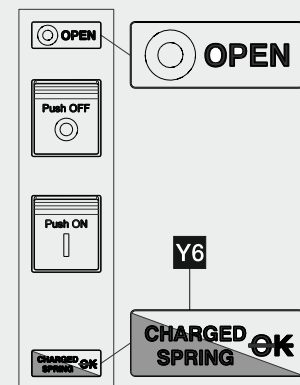

REGOLAZIONE:

N.B. Nelle regolazioni quando si agisce sui dadi non far ruotare su sé stessi i puntali dei cavi

- 1 Inserire le parti mobili nelle parti fisse (se estraibili) e sganciare la molla
- 2 Chiudere l'interruttore "CB1"
- 3.1 Tirare il cavo "Y2" dell'interruttore chiuso verso il basso/alto fino a portare il tirante "Y4" dell'interruttore aperto in battuta sul piano "Y3"
- 3.2 Bloccare il grano "Y1" (1,5 Nm / 13.3 lb in) e chiudere il relativo controdado "Y5" (1.5 Nm / 13.3 lb in)
- 4 Aprire l'interruttore "CB1"
- 5 Chiudere l'interruttore "CB2" e ripetere i punti 3.1 e 3.2
- 6 Aprire l'interruttore "CB2"
- 7 Eseguire alcune manovre di chiusura e apertura, quindi verificare la battuta dei tiranti "Y4" sul piano "Y3"
- 8 Aprire l'interruttore chiuso e riagganciare la molla
- 9 Chiudere l'interruttore E1.2 e caricare le molle di chiusura dell'interruttore "CB2"
- 10 Muovere in direzione verticale la slitta "Y8" dell'interruttore "CB2" fino a portare il segnalatore "Y6" centrato nella finestra. Se necessario, è possibile modificare la quota 22 (0.86") agendo sui dadi "Y7" rispettando i valori min. e max. indicati
- 11 Ribloccare i dadi "Y7" (3 Nm / 26.5 lb-in)
- 12 Aprire l'interruttore "CB1"
- 13 Chiudere e aprire l'interruttore "CB2" per scaricare le molle
- 14 Eseguire alcune manovre di chiusura e apertura, quindi verificare la battuta dei tiranti "Y4" sul piano "Y3"

ADJUSTMENT:

N.B. During adjustments, when tightening or loosening the nuts do not allow the tips of the cables to rotate on themselves

- 1 Fit moving parts into fixed parts (if withdrawable) and release the spring
- 2 Close circuit-breaker "CB1"
- 3.1 Pull cable "Y2" of the closed circuit-breaker down/upwards until the tie rod "Y4" of the open circuit-breaker touches the surface "Y3"
- 3.2 Lock the grub screw M4 "Y1" (1.5 Nm / 13.3 lb in) and close the corresponding lock nut (1.5 Nm / 13.3 lb in)
- 4 Open circuit-breaker "CB1"
- 5 Close circuit-breaker "CB2" and repeat steps 3.1 e 3.2
- 6 Open circuit breaker "CB2"
- 7 Perform a few opening and closing operations, than check that the tie rods "Y4" are touching against the surface "Y3"
- 8 Open closed circuit-breaker and hook up the spring again
- 9 Close circuit-breaker E1.2 and charge circuit-breaker "CB2" closing springs
- 10 Move slide "Y8" of the circuit-breaker "CB2" in vertical direction until the indicator "Y6" is centered in the window. If necessary, it is possible to adjust dimension 22 (0.86") operating on nuts "Y7" within the min. and max. values shown
- 11 Lock nuts "Y7" (3Nm / 26,5 lb-in)
- 12 Open circuit-breaker "CB1"
- 13 Close and re-open breaker "CB2" to discharge the springs
- 14 Perform a few opening and closing operations, than check that the tie rods "Y4" are touching against the surface "Y3"

EINSTELLUNG:

Anm.: Bei den Einstellungen, wenn man die Muttern dreht, die Klemmen der Kabel nicht auf sich selbst drehen lassen

- 1 Die beweglichen Teile in die festen Teile (sofern ausziehbar) einfahren und die Feder ausrasten lassen
- 2 Den Leistungsschalter "CB1" einschalten
- 3.1 Das Kabel "Y2" des eingeschalteten Leistungsschalters nach runter/aufwärts ziehen, bis der Zuganker "Y4" des ausgeschalteten Leistungsschalters in Anschlag auf der Fläche "Y3" gebracht wird
- 3.2 Die Madenschraube M4 "Y1" (1,5 Nm / 13.3 lb in) blockieren und die entsprechende Gegenmutter (1.5 Nm / 13.3 lb in) schließen
- 4 Den Leistungsschalter "CB1" ausschalten
- 5 Den Leistungsschalter "CB2" einschalten und die Punkte 3.1 und 3.2 wiederholen
- 6 Den Leistungsschalter "CB2" ausschalten
- 7 Ein paar Ein- und Ausschaltungen ausführen, dann den Anschlag der Zuganker "Y4" auf der Fläche "Y3" prüfen
- 8 Den eingeschalteten Leistungsschalter öffnen und die Feder wieder einrasten lassen
- 9 Den Leistungsschalter E1.2 einschalten und die Einschaltfedern des Leistungsschalters „CB2“ spannen.
- 10 Den Schlitten „Y8“ des Leistungsschalters in vertikaler Richtung bewegen, bis die Anzeige „Y6“ in der Mitte des Fensters steht. Bei Bedarf ist es möglich, den Wert 22 (0.86") mit den Muttern „Y7“ zu ändern, wenn die angegebenen kleinsten und größten Werte eingehalten werden.
- 11 Die Muttern „Y7“ wieder anziehen (3 Nm / 26.5 lb-in)
- 12 Den Leistungsschalter "CB1" ausschalten
- 13 Den Leistungsschalter "CB2" einschalten und wieder ausschalten, um die Federn zu entspannen
- 14 Ein paar Ein- und Ausschaltungen ausführen, dann den Anschlag der Zuganker "Y4" auf der Fläche "Y3" prüfen

RÉGLAGE:

N.B. Dans les réglages, lors de l'action sur les écrous, ne pas faire tourner sur eux-mêmes les embouts des câbles

- 1 Introduire les parties mobiles dans les parties fixes (si débrochables) et décrocher le ressort
- 2 Fermer le disjoncteur "CB1"
- 3.1 Tirer le câble "Y2" du disjoncteur fermé vers le bas/haut jusqu'à mettre le tirant "Y4" du disjoncteur ouvert en butée contre le plan "Y3"
- 3.2 Bloquer la vis sans tête M4 "Y1" (1,5 Nm / 13.3 lb in) et serrer le contre-écrou (1.5 Nm / 13.3 lb in)
- 4 Ouvrir le disjoncteur "CB1"
- 5 Fermer le disjoncteur "CB2" et répéter les points 3.1 et 3.2
- 6 Ouvrir le disjoncteur "CB2"
- 7 Effectuer quelques manœuvres de fermeture et d'ouverture, puis vérifier la butée des tirants "Y4" sur le plan "Y3"
- 8 Ouvrir le disjoncteur fermé et raccrocher le ressort
- 9 Fermer le disjoncteur E1.2 et bander les ressorts de fermeture du disjoncteur "CB2"
- 10 Déplacer le coulisseau "Y8" dans le sens vertical du disjoncteur "CB2" jusqu'à placer l'indicateur "Y6" centré dans la fenêtre. Si nécessaire il est possible de modifier la cote 22 (0.86") en agissant sur les écrous "Y7" en respectant les valeurs mini. et max. indiquées
- 11 Rebloquer les écrous "Y7" (3 Nm / 26.5 lb-in)
- 12 Ouvrir le disjoncteur "CB1"
- 13 Fermer et rouvrir le disjoncteur "CB2" pour débander les ressorts
- 14 Effectuer quelques manœuvres de fermeture et d'ouverture, puis vérifier la butée des tirants "Y4" sur le plan "Y3"

REGULACIÓN:

NOTA: En las regulaciones cuando se opera con las tuercas no hacer girar sobre sí mismos los terminales de los cables

- 1 Introducir las partes móviles en las partes fijas (si son extraíbles) y desenganchar el resorte
- 2 Cerrar el interruptor "CB1"
- 3.1 Tirar del cable "Y2" del interruptor cerrado hacia abajo/arriba hasta llevar el tirante "Y4" del interruptor abierto tocando sobre la superficie "Y3"
- 3.2 Bloquear el pasador M4 "Y1" (1,5 Nm / 13.3 lb in) y ajustar la correspondiente contratuerca (1.5 Nm / 13.3 lb in)
- 4 Abrir el interruptor "CB1"
- 5 Cerrar el interruptor "CB2" y repetir los puntos 3.1 y 3.2
- 6 Abrir el interruptor "CB2"
- 7 Efectuar algunas maniobras de cierre y apertura, luego verificar que los tirantes "Y4" hagan tope sobre la superficie "Y3"
- 8 Abrir el interruptor cerrado y reenganchar el resorte
- 9 Cerrar el interruptor E1.2 y cargar los resortes de cierre del interruptor "CB2"
- 10 Mover en dirección vertical la corredera "Y8" del interruptor "CB2" hasta llevar el indicador "Y6" centrado en la ventana. Si es necesario es posible modificar la cota 22 (0.86") operando con las tuercas "Y7", respetando los valores mín. y máx. indicados
- 11 Volver a bloquear las tuercas "Y7" (3 Nm / 26.5 lb-in)
- 12 Abrir el interruptor "CB1"
- 13 Cerrar y reabrir el interruptor "CB2" para descargar los resortes
- 14 Efectuar algunas maniobras de cierre y apertura, luego verificar que los tirantes "Y4" hagan tope sobre la superficie "Y3"

CONTROLLO MECCANICO:

Riarmare le molle dei comandi degli interruttori ed eseguire le seguenti operazioni:

- 1 Chiudere l'interruttore "CB1" e controllare che l'interruttore "CB2" non possa essere chiuso.
Riarmare le molle del comando dell' interruttore "CB1"
verificando che lo stesso resti in chiuso, quindi aprire l'interruttore "CB1".
- 2 Chiudere l'interruttore "CB2" e controllare che l'interruttore "CB1" non possa essere chiuso.
Riarmare le molle del comando dell'interruttore "CB2"
verificando che lo stesso resti in chiuso, quindi aprire l'interruttore "CB2".
- 3 Ripetere il test per tre volte. Al termine dei test verificare le regolazioni e il bloccaggio dei tiranti.

MECHANICAL CHECK:

Reset the springs of the operating mechanisms of the circuit-breakers and perform the following operations:

- 1 Close circuit-breaker "CB1" and make sure that circuit-breaker "CB2" cannot be closed.
Reset the springs of circuit-breaker "CB1" operating mechanism,
checking that the circuit-breaker remains closed, then open circuit-breaker "CB1".
- 2 Close circuit-breaker "CB2" and make sure that circuit-breaker "CB1" cannot be closed.
Reset the springs of circuit-breaker "CB2" checking that the
circuit-breaker remains closed, then open circuit-breaker "CB2".
- 3 Repeat the test three times. When the tests are completed check the adjustments and the locking of the tie rods.

MECHANISCHE KONTROLLE:

Die Federn der Antriebe der Leistungsschalter rückstellen und die folgenden Vorgänge ausführen:

- 1 Den Leistungsschalter "CB1" einschalten und sicherstellen, dass der Leistungsschalter "CB2" nicht eingeschaltet werden kann.
Die Federn des Antriebs von Leistungsschalter "CB1" rückstellen und sicherstellen,
dass er eingeschaltet bleibt, dann den Leistungsschalter "CB1" ausschalten.
- 2 Den Leistungsschalter "CB2" einschalten und sicherstellen, dass der Leistungsschalter "CB1" nicht eingeschaltet werden kann.
Die Federn des Antriebs von Leistungsschalter "CB2" rückstellen und sicherstellen,
dass er eingeschaltet bleibt, dann den Leistungsschalter "CB2" ausschalten.
- 3 Den Test drei Mal wiederholen. Am Ende des Tests die Einstellungen und den festen Sitz der Zuganker sicherstellen.

CONTROLE MÉCANIQUE:

Réarmer les ressorts des commandes des disjoncteurs et effectuer les opérations suivantes:

- 1 Fermer le disjoncteur "CB1" et contrôler que le disjoncteur "CB2" ne puisse pas être fermé.
Réarmer les ressorts de la commande du disjoncteur "CB1"
en vérifiant que celui-ci reste en fermé, puis ouvrir le disjoncteur "CB1".
- 2 Fermer le disjoncteur "CB2" et contrôler que le disjoncteur "CB1" ne puisse pas être fermé.
Réarmer les ressorts de la commande du disjoncteur "CB2"
en vérifiant que celui-ci reste en fermé, puis ouvrir le disjoncteur "CB2".
- 3 Répéter le test trois fois. A la fin des tests vérifier les réglages et le blocage des tirants.

CONTROL MECÁNICO:

Rearmar los resortes de los mandos de los interruptores y efectuar las siguientes operaciones:

- 1 Cerrar el interruptor "CB1" y controlar que no pueda cerrarse el interruptor "CB2".
Rearmar los resortes del mando del interruptor "CB1"
verificando que el mismo quede cerrado, luego abrir el interruptor "CB1".
- 2 Cerrar el interruptor "CB2" y controlar que no pueda cerrarse el interruptor "CB1".
Rearmar los resortes del mando del interruptor "CB2"
verificando que el mismo quede cerrado, luego abrir el interruptor "CB2".
- 3 Repetir el test tres veces. Al finalizar las pruebas verificar las regulaciones y el bloqueo de los tirantes.

Eseguire le operazioni di manutenzione delle figure 45-46 secondo le modalità indicate nella figura 44

Perform maintenance operations of figures 45-46 according to the procedures indicated in the figure 44

Die Wartungsvorgänge nach den Modalitäten ausführen der Abb. 45-46 und die in der Abb. 44

Exécuter les opérations de maintenance des les figures 45-46 selon les modalités indiquées dans la figure 44

Efectuar las tareas de mantenimiento de las figuras 45-46 siguiendo las modalidades indicadas en la figura 44



ATTENZIONE: gli interblocchi non possono essere verificati nelle posizioni Test o Estratto

WARNING: the interlocks cannot be tested in the Test or Disconnected positions

ACHTUNG: Die Verriegelungen können in der Test- oder Außenstellung nicht geprüft werden

ATTENTION: les verrouillages ne peuvent pas être vérifiés dans les positions Test ou Débroché

ATENCIÓN: los enclavamientos no pueden ser controlados en las posiciones Prueba o Extraído

Attività	Frequenza	Azioni di manutenzione
Funzionalità	Un anno o 20% della vita meccanica o 20% della vita elettrica	Vedi paragrafo: Controllo Meccanico
Controllo di serraggio		Vedi foglio kit
Lubrificazione		Applicare dove è presente  nel foglio kit e dove mostrato nelle figure seguenti
Cavi	- Tre anni o 50% della vita meccanica or 50% della vita elettrica dell'interruttore di taglia maggiore coinvolto nell'interblocco - Dopo un intervento a seguito di corto circuito	Consigliata la sostituzione

Activity	Frequency	Maintenance Action
Functionality	One year or 20% of mechanical life or 20% of electrical life	See paragraph: Mechanical check
Tightening check		See kit sheet
Lubrification		To be applied where  is present in the kit sheet and where shown in the figure below
Cables	- Three years or 50% of mechanical life or 50% of electrical life of the higher frame breaker involved in the interblock - After a trip due to a short-circuit	Replacement is suggested

Tätigkeit	Frequenz	Wartungsvorgänge
Funktionen	Ein Jahr oder 20% der mechanischen Lebensdauer oder 20% der elektrischen Lebensdauer	Siehe Abschnitt: Mechanische kontrolle
Kontrolle des Anzugsmoments		Siehe das Blatt von Bausatz
Schmierung		Anzuwenden dort, wo es  im Bausatzblatt angegeben ist und wo es in der Abbildung unten dargestellt ist.
Kabel	- Drei Jahre oder 50% der mechanischen Lebensdauer oder 50% der elektrischen Lebensdauer des größten Leistungsschalters, der mit der Verriegelung verbunden ist - Nach einem Eingriff infolge eines Kurzschlusses	Der Austausch ist zu empfehlen

Activité	Frequence	Actions de maintenance
Fonctionnalités	Un an ou 20% de l'endurance mécanique ou 20% de l'endurance électrique	Voir paragraphe: Controle mécanique
Contrôle de serrage		Voir la fiche kit
Lubrification		Appliquer aux endroits  indiqués sur la fiche du kit et aux endroits indiqués sur la figure ci-dessous.
Câbles	- Trois ans ou 50% de l'endurance mécanique ou 50% de l'endurance électrique du disjoncteur de taille supérieure impliqué dans le verrouillage - Après une intervention à la suite d'un court-circuit	Le remplacement est conseillé

Actividad	Frecuencia	Acciones de mantenimiento
Funcionalidades	Un año o 20% de la vida mecánica o 20% de la vida eléctrica	Véase el apartado: Control mecánico
Control de apriete		Véase la hoja kit
Lubrificación		Se aplica donde esté  presente en la hoja del kit y donde se muestra en la figura a continuación.
Cables	- Tres años o 50% de la vida mecánica o 50% de la vida eléctrica del interruptor de mayor tamaño implicado en el enclavamiento - Después de una actuación por cortocircuito	Aconsejada la sustitución

