

## Data Sheet | Item Number: 891-8995/206-201

pre-assembled connecting cable; Eca; Plug/open-ended; 5-pole; Cod. A; H05VV-F  
5G 1.5 mm<sup>2</sup>; 2 m; 1,50 mm<sup>2</sup>; black

<https://www.wago.com/891-8995/206-201>

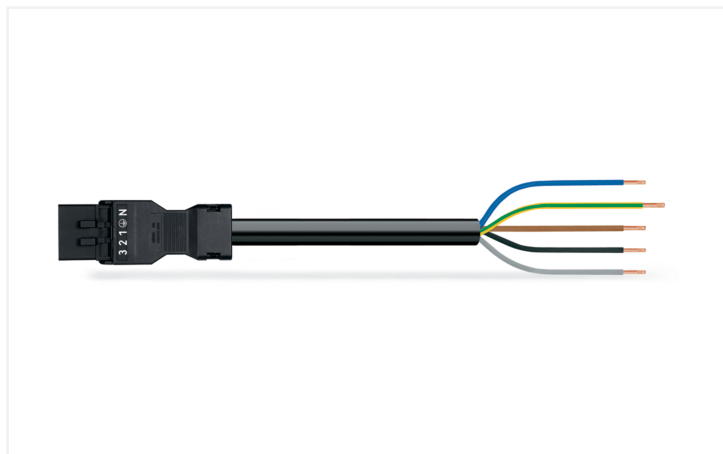

Color: ■ black

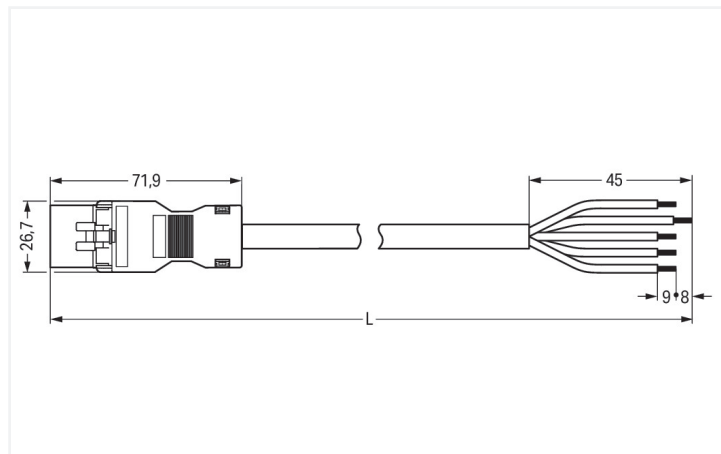

Dimensions in mm

Cable assembly *WINSTA*® MINI with protection type IP20

For signal and power transmission: The *WINSTA*® MINI cable assembly rated current 13 A. On PCBs, in control cabinets or for connecting lights – pluggable installation connectors from WAGO allow you to make connections according to various requirements in no time flat. The coding options reduce installation errors, allowing fast, secure wiring of all components. Thanks to the color coding and mechanical A coding of *WINSTA*® MINI pluggable installation connectors, you can clearly distinguish different circuits. *WINSTA*® MINI satisfies the demand for miniaturisation. Our smallest pluggable connection system is especially suitable for lights, for instance, since due to LED technology, these offer less and less space for the connection technology. Of course, the safety of buildings must always be ensured, even after the electrical installation has been performed. The required safety requirements in connection with EU CPR are fully satisfied by this product through fire class E.

Fast, secure pluggable connections – cable assemblies from WAGO

A plug and a free end are provided. *WINSTA*® is the pluggable connection system that is optimally tailored to the strict requirements of electrical installation. It offers fast, secure and, above all, error-free installation of components and cables. Take advantage of the pluggable version of our maintenance-free spring pressure connection technology too! Plan your installation with with protection against mismatching from WAGO.

- protection against mismatching eliminates errors
- compact design for conductors with a cross-section up to 1.5 mm<sup>2</sup>
- with A coding for a great number of uses
- ready for immediate use
- rapid, structured electrical installation

### Notes

Note Cables with a different fire class can be found in the eShop.

### Electrical data

Ratings per	IEC/EN 60664-1		
Overvoltage category	III	III	II
Pollution degree	3	2	2
Nominal voltage	400 V	-	-
Rated impulse withstand voltage	6 kV	-	-
Rated current	13 A	-	-

### General information

Note on contact resistance approx. 1 mΩ of contact resistance  
approx. 0.25 mΩ contact transition plug/  
socket

## Connection Data

Total number of potentials	5	<b>Connection 1</b>	
Conductor preparation	ultrasonically tip-bonded	Strip length	9 mm / 0.35 inches
		Pole number	5
		Wire cross-section	1.5 mm <sup>2</sup>
		Strip length (outer insulation)	45 mm
		Connection type	Plug - free end

## Physical data

Pin spacing	4.4 mm / 0.173 inches
Width	26.7 mm / 1.051 inches
Height	15.8 mm / 0.622 inches
Total length	2 m

## Mechanical data

Use	General mains applications
Coding	A
Variable coding	No
Marking	N ⊕ 1 2 3
Potential marking	N ⊕ 1 2 3
Mating force of a plug-in connection	approx. 20 ... 70 N (depending on pole number)
Retention force of a plug-in connection	when locked: > 80N
Unmating force of a plug-in connection	when unlocked: approx. 20 ... 70 N (depending on pole number)
Number of mating cycles	200, without resistive load
Connection type	Plug - free end
Type of pre-assembled cable	Connecting cable
Cable type	H05VV-F 5G1.5
Protection type	IP20; IP40 when mated

## Plug-in connection

Mismating protection	Yes
Note on mismating protection	All <i>WINSTA</i> ® components are 100% protected against mismating when: a.) plugging different numbers of poles b.) plugging while rotated 180 c.) plugging while laterally staggered d.) plugging one pole
Locking lever	Can be retrofitted
Locking of plug-in connection	Locking lever
Note on locking system	All connectors for mounted installations (snap-in versions for lighting fixtures or devices, all types of PCB and distribution connectors) are factory-equipped with locking levers to ensure plugs and sockets are securely locked. Additional locking levers are only required for flying leads (plug/socket).

## Material data

Note (material data)	<a href="#">Information on material specifications can be found here</a>
Color	black
Insulation material (main housing)	Polyamide (PA66)
Fire class per EN 50575	E <sub>ca</sub>
Contact material	Copper or copper alloy; surface-treated
Contact Plating	Tin
Fire load	59.947 MJ
Connector color	black
Strain relief color	black
Sheathed cable color	black

### Material data

Printing color of sheathed cable	white
Halogen-free	No
Silicon-free	Yes
Sheath material	PVC
Rubber cable	No
Weight	326 g
Copper weight of the raw cable	0.072 kg/m

### Environmental requirements

Processing temperature	-5 ... +40 °C
Continuous operating temperature	-35 ... +85 °C
Note on continuous operating temperature	Cable for temperatures ≤ 70 °C (including halogen-free) Insulating parts for temperatures ≤ 105 °C

### Commercial data

PU (SPU)	1 pcs
Packaging type	unpacked
Country of origin	PL
GTIN	4055143386692
Customs tariff number	85444290900

### Product Classification

UNSPSC	26121629
eCl@ss 10.0	27-44-06-04
eCl@ss 9.0	27-44-06-04
ETIM 9.0	EC002587
ETIM 10.0	EC002587
ECCN	NO US CLASSIFICATION

### Environmental Product Compliance

RoHS Compliance Status	Compliant, No Exemption
------------------------	-------------------------

### Approvals / Certificates

#### General approvals



Approval	Standard	Certificate Name
CCA DEKRA Certification B.V.	EN 61535	NTR NL-7971
KEMA/KEUR DEKRA Certification B.V.	EN 61535	71-123232

#### Declarations of conformity and manufacturer's declarations

Approval	Standard	Certificate Name
EU-Declaration of Conformity WAGO GmbH & Co. KG	-	-
UK-Declaration of Conformity WAGO GmbH & Co. KG	-	-

## Downloads

### Environmental Product Compliance

Compliance Search			
Environmental Product Compliance			↓
891-8995/206-201			

## Documentation

Bid Text			
891-8995/206-201	19.02.2019	xml 2.98 KB	↓
891-8995/206-201	01.12.2014	doc 25.00 KB	↓

## CAD/CAE-Data

CAE data	
EPLAN Data Portal 891-8995/206-201	↓
WSCAD Universe 891-8995/206-201	↓

## 1 Compatible Products

### 1.1 Required Accessories

#### 1.1.1 Locking system

##### 1.1.1.1 Locking system



[Item No.: 890-111](#)  
Locking lever; for flying leads; for tool operation; black

[Item No.: 890-131](#)  
Locking lever; for flying leads; for tool operation; white

[Item No.: 890-101](#)  
Locking lever; for manual operation; black

[Item No.: 890-121](#)  
Locking lever; for manual operation; white

### 1.2 Optional Accessories

#### 1.2.1 Cover

##### 1.2.1.1 Cover



[Item No.: 897-2003](#)  
Protective cap; Type2; for sockets and plugs; PVC; red

## 1.2.2 Installation

### 1.2.2.1 Mounting accessories



**Item No.: 890-310**

Mounting carrier; 2- to 5-pole; for flying leads; black



**Item No.: 890-311**

Mounting carrier; 2- to 5-pole; for flying leads; white